



# aFe PRODUCT CATALOG

**High Performance OE Replacement Filters**



**High Performance Air Intake Systems**



**Mandrel-Bent Exhaust Systems**



**Manifolds & Intercoolers**



**Full Metal Power**





# aFe PRODUCT CATALOG

## Filter Media

Basic comparison of common filter medias - paper, foam and cotton gauze

Paper			<p>Tightly compressed cellulose fibers bonded together provide very small pores. Dust is captured on the surface as air flows through small pores. Restriction increases as dust accumulates on the surface. Very good filtration but poor airflow. Very limited service life. Not reusable.</p>
Foam			<p>Synthetic foam provides larger pores than paper and compensates with thicker material. Often utilizes a very tacky tackifier to capture dust. Restriction increases as dust accumulates on the surface. Good airflow until dirt builds up on surface. Limited service life due to no depth loading. Washable but difficult to clean.</p>
Gauze			<p>Cotton gauze media provides large pores with micro-fibers extending into the pores. Multiple layers of gauze increases filtrations as they overlap. Oil is used a tackifier lubricating the microfibers capturing dust particles as they come in contact. Excellent airflow. Filtration efficiency improves as dust accumulates. Washable and easy to clean and reoil.</p>

Comparison between aFe cotton gauze and competition's gauze media

Multiple layers of constant mesh gauze: 4 of same thread count gauze stacked.

Competition			<p>Competitive cotton gauze show many large black spaces between threads. Black spots equate to voids/openings that do not have any filter media. Dirty air can pass through with minimal filtration.</p>
-------------	--	--	---

Multiple layers of progressive mesh gauze: 5 layers of progressively higher thread count gauze stacked. higher thread count equate to smaller and smaller openings.

aFe			<p>aFe Pro5R progressive cotton gauze show minimal and only minute black spaces between threads. As different thread count gauze are stacked, randomness of opening increase, minimizing spaces with no filter media.</p>
-----	--	--	---



# aFe PRODUCT CATALOG

## Filter Media

Why “Progressive” and what’s the advantage?

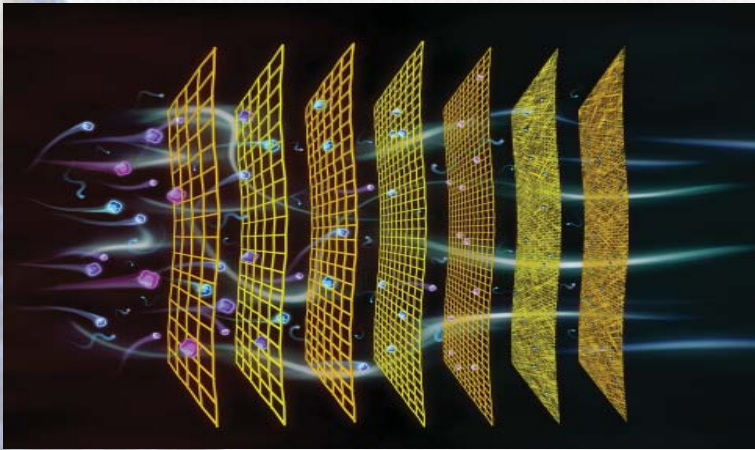

Imagine airflow as a stream or river and dust particles as different size fish and the progressively finer cotton gauze are nets with smaller and smaller grid size. The largest fish will be captured by the first net allowing smaller fish swim more freely and the water to flow freely until the next largest fish are caught in the next net. The tiniest fish will be caught in the last net but the water is allowed to flow freely as larger fish have been removed earlier. However, when all the nets are the same grid size, the small fish are only caught when enough large fish are caught in the nets to trap the small fish. But this also hinders the flow of water.

“Maximum Airflow” Pro5R Media - 5 layers cotton gauze, oil impregnated

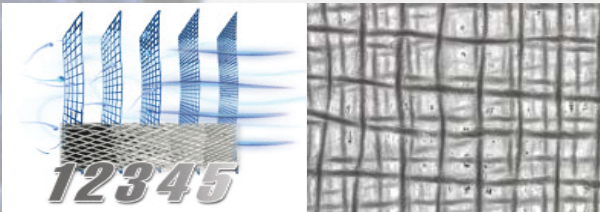

As described above, progressively finer mesh cotton gauze provides maximum airflow while ensuring good initial filtration efficiency. Depth loading of dust onto multiple layers provides for high dust holding capacity and high cumulative filtration efficiency and longer service intervals. Airflow is the best with Pro5 R resulting in greatest gain in horsepower compared to other two medias.

“Maximum Convenience” ProDryS Media - 2 layers synthetic, oil-free

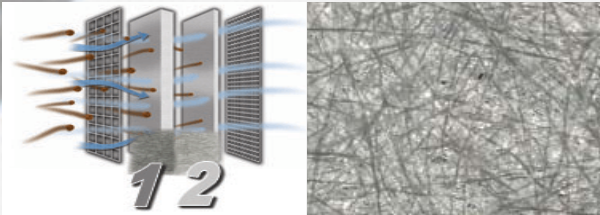

For vehicle owners on the go, aFe offers an oil-free media with two layers of different porosity synthetic media. Synthetic media requires no oiling and dries quicker because it retains little moisture.

**HP: 5%<Pro5R**

**CFM: 10%<Pro5R**

“Maximum Protection” ProGuard7 Media - 5 layers cotton gauze plus 2 layer synthetic, oil impregnated.

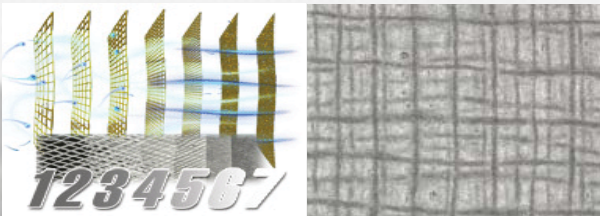

For vehicles such as turbo diesels that require a lot of clean air, aFe adds two layers of progressively finer porosity synthetic media to stop the finest of dust particles. High initial filtration efficiency ensure the engine gets the cleanest air right from the start for maximum protection.

**HP: 10%<Pro5R**

**CFM: 20%<Pro5R**

### What is filtration efficiency and how does aFe’s medias compare with the competition

Filtration efficiency is a measure of the amount of dirt that is passed by the filter and is calculated measuring the weight of the “absolute” filter before and after the test and comparing it with the amount of test dust used in the test.

Element ID	Pleats	Test Dust	Initial Delta P	Flow@1.5” H <sub>2</sub> O	Initial Eff.	Cumulative Eff.	Dust Capacity
ProR5	45	Course	.27	369	na	98.52	207.88
ProDryS	45	Course	.32	323	na	99.03	113.53
ProGUARD 7	45	Course	.37	290	na	99.52	181.91
ProGUARD 7	30	Course	.88	na	98.95	99.51	485
ProGUARD 7	30	Fine	.86	na	96.74	98.49	382
Brand K	30	Course	.78	na	97.11	99.05	305



# aFe PRODUCT CATALOG

## Filter Construction

Competitive Brand

aFe

Filter Media

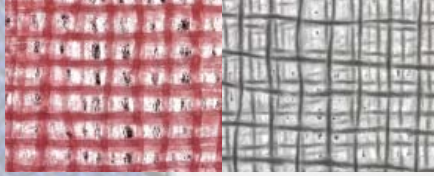

- Progressive 5-layer (Pro5R), 7-layer (ProGUARD 7) and 3 layer (ProDryS).
- Smaller, denser pores ensure better filtration.
- Depth-loading increases dust holding capacity.

Pleat Geometry



- Evenly spaced rounded pleat tips for better airflow.
- Lower face resistance as air flows through tips.
- Consistent spacing results in greater dust holding capacity.



Pleat Height

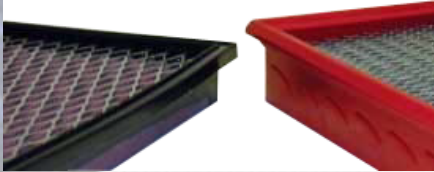

- 30% taller pleat height provides for greater dust holding capacity.
- More media results in longer service cycle and fewer cleanings.
- Less frequent cleaning ensures longer service life.

Seal Design



- Progressive bump seal ensures air tight seal without gasket or grease.
- 100% engineering grade polyurethane remains pliable for years.
- Chemical and heat resistant polyurethane ensure long filter life.

Expanded Metal

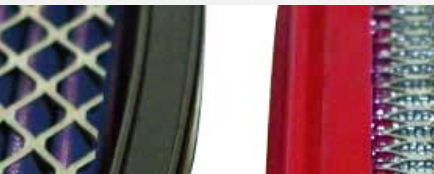

- Available on all diesel filters to add rigidity and strength.
- Expanded metal is molded into the urethane rather than loose.
- Embedded expanded metal will not cut or scratch during handling.

Filter Construction



- Flat panel filters constructed with 4 sides not just 2.
- 4-sided design adds rigidity and seal support.
- Depth-loading dust holding capacity

Velocity stack

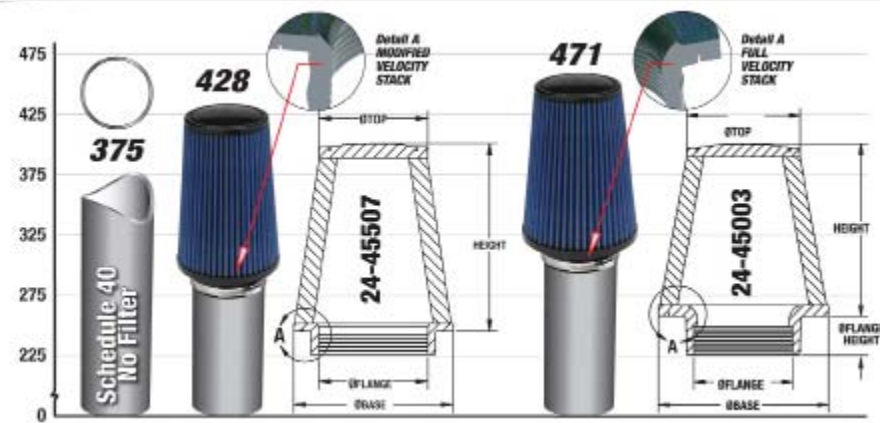

- Full and modified velocity stack available in most sizes.
- Velocity stack increases the effective diameter of the tube.
- Modified velocity stack allows for maximum airflow in limited base dimensions.



# aFe PRODUCT CATALOG

## Filter Types

### OE Replacement- Round, Non-Flat

Whether round, oval, conical or cylindrical, these non-flat OE replacement performance filters are designed to fit perfectly into the stock airbox, flow better and last longer than the original paper filter element



10-xxxxx



11-xxxxx



71-xxxxx



### OE Replacement - Flat Performance

Usually 4 sided but can be five or six sided, these flat panel OE replacement performance filters are designed to fit perfectly into the stock airbox, flow better and last longer than the original paper filter element

30-xxxxx

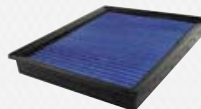

31-xxxxx

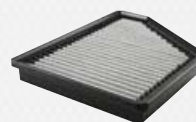

73-xxxxx

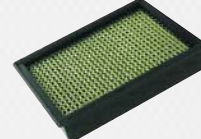

### OE Replacement - IRF Performance

Designed to fit into the same stock airbox that our standard flat panel filter goes into, these Inverted Replacement filters provide considerable more flow and media than standard flat filters.

30-8xxxx

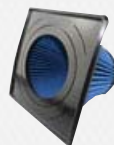

31-8xxxx



71-8xxxx

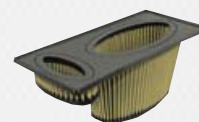

### Racing Filters - Round

Available in all standard racing dimensions, these high flow, high capacity round racing filters are available in popular 9", 11", 12", 14" and 16" diameters.

18-1xx0x

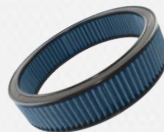

18-1xx2x



18-1xx7x

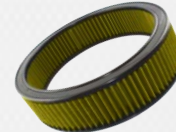

### Racing Filters - T.O.P.

These patented one piece air filters, appropriately call The One Piece, incorporate a top filter elements that is molded into the urethane. This ensure a long durable seal while allowing additional airflow for that competitive edge.

18-3xx0x



18-3xx2x



### Universal Clamp On

These patented one piece air filters, appropriately call The One Piece, incorporate a top filter elements that is molded into the urethane. This ensure a long durable seal while allowing additional airflow for that competitive edge.

24-xxxxx



21-xxxxx



72-xxxxx





# aFe PRODUCT CATALOG

## Air Intake Systems - Features



aFe intake systems are more than a filter on a tube. we control the dynamics of how the air flows into the engine from start to finish.

1. Largest possible 360 degree radial filter design to allow maximum air.
2. Heavy-duty 16 guage steel or molded plastic heat shield enclosure.
3. Velocity stack on filter or 3-angle adaptor smoothes transition to tube.
4. Built-in Mass Airflow Sensor pad that position the MAF sensor just right to prevent CEL error codes.
5. Rotomolded tube or mandrel-bent tube smoothly directs to the throttle body or turbo.

**Air Filter**

1. Unlike some of our competitors, aFe makes our own filters. So we are not limited in the size or shape of our filters. In addition, we incorporate features that add value.

Velocity Stack      Minimal wicking      Inverted top      Clamp Stops

**Housing 16-Guage Steel**

2. aFe offers 1 piece 16-guage powder-coated steel housing with features such as:

Louvered vents      Battery tray      Welded-on bracket      Pre-positioned nutserts

**Rotomolded plastic**

Other systems come with 1-piece rotomolded housing with these features.

Molded brackets      Pre-positioned nutserts      Auxiliary air scoop      4.8mm thick wall

**Intake Tube Molded Plastic**

3. aFe offers some systems w/rotomolded intake tubes with unique features such as:

Molded flange      Embedded nutserts      Smooth contours      Molded MAF pad

**Other value adding features**

4. Many of aFe intake systems incorporate features to enhance performance, durability and appearance such as:

3-angle filter adaptor      Stainless steel button head screws      Rubber trim seal for systems w/o covers      Clear-coat brushed aluminum cover      Scoops to direct airflow to airbox      Intake duct to direct airflow to airbox



# aFe PRODUCT CATALOG

## Air Intake Systems

### Magnum Force - Stage 1

Stage 1 intake systems generally replaces the stock air box and retains the stock intake tract. By replacing the restrictive stock air box, the budget-minded user is able still get good performance without

### Magnum Force - Stage 2

Stage 2 intake systems replaces both the stock air box and the stock intake tract. By replacing the entire stock intake system, the performance-minded user achieves maximum performance with greatest airflow.

### Magnum Force - Stage 2 Si

"Si" stands for "sealed intake". This Stage 2 intake system replaces both the stock air box and intake tract but the air box is a totally enclosed air box that closely resembles the stock air but but delivering much better performance.

### Magnum Force - Stage 2 Value Pack

A Stage 2 intake system with value pack includes additional parts like a a service filter, pre-filter and a filter restore kit.

### Magnum Force - Super Stock

Super Stock systems generally includes a OE replacement filter and intake tube. These systems are available for the consumer that want some performance but prefer to retain the stock air box.



54-xxxx1



51-xxxx1



75-xxxx1



54-xxxx2



51-xxxx2



75-xxxx2



54-8xxx2



51-8xxx2



75-8xxx2



54-8xxx2-xV



51-8xxx2-xV



75-8xxx2-xV



55-xxxx0



55-xxxx1



### Full Metal Power

A new line of intake systems for gas and diesel truck owners that prefer a "shiny tube" that enhances the appearance of the engine compartment as much as performance.



F1-02xxx



F1-03xxx



F1-04xxx





# aFe PRODUCT CATALOG

## Exhaust Systems - Features

**LARGE BORE HD**  
Exhaust

**MACH FORCE XP**  
EXHAUST

Mandrel-bent tubes



aFe exhaust systems are constructed of mandrel-bent 409 stainless steel tubes. Mandrel-bending ensures the tubing maintains its shape and size throughout the entire length, providing smooth, unrestricted airflow. Standard tubing can lose as much as 20% of its diameter in sharp bends.

Bayonet hangers



Swagged bayonet ends lock exhaust components into place for the most secure installation, preventing tubes and parts from sliding and cause premature wear or damage. Whenever possible, our hangers are wrapped around the tube and welded. U-bolt clamps with welded hangers are used where necessary.

Band clamps



Premium-quality band clamps are used on critical joints to provide the tightest, leak-free seal possible. Instead of the lower costing U-bolt clamps, band clamps offer full 360 degree engagement. aFe even uses band clamps on their tips

Flange styles



Whether turbo-back, cat-back or DPF-back, aFe utilizes flange configurations that match up to the OE set-up to ensure easy installation and, if necessary, easy return to stock. With flanges that match up to OE set-up, there is no need to cut the stock system.

Fittings & Brackets



With the newer diesel pickup trucks with Diesel Particulate Filters (DPF), replacing the factory exhaust requires various bungs for factory sensors and input lines. aFe provide fully welded bungs for such sensors. In addition, aFe provide brackets to utilize factory mounting points.

Slotted or Swedged

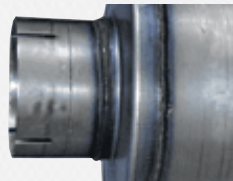

To ensure tight, leak-free installation, aFe utilizes slotted and swedged ends wherever possible. Swedged sleeves also makes it easier to install the exhaust system. Used in conjunction with band clamps, these features make aFe exhaust systems a joy to work with.

Tips Styles



Complementing our 409 stainless steel exhaust systems, aFe offers a variety of exhaust tips that enhances the appearance of the system as well as the vehicle. These tips are offered in polished 304 stainless and matte-black, hi-temp black, ranging from 12" to 18" lengths and 3.5" to 6" in diameter. Tips are included in all Mach Force Xp exhaust systems.

Muffler

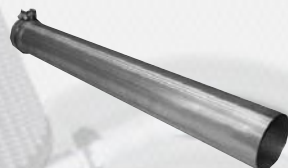

aFe offers a 8" diameter x 30" length, straight, flow through perforated exhaust muffler in all its exhaust systems. In the Mach Force Xp, aFe also includes a straight, muffer-delete pipe in addition to the muffler for those owners that prefer a more aggressive sound from their exhaust system.





# aFe PRODUCT CATALOG

## Exhaust Systems - Type

### Diesel

#### Turbo-Back

These are examples of turbo-back exhaust systems that include the downpipe. All Mach Force XP systems come with polished 304 stainless steel tips and muffler delete pipes. Large Bore HD do not and start with "49-1".

#### Cat-Back

These are examples of cat-back exhaust systems that retain the factory catalytic converter.

#### DPF-Back

From 2007.5 on, OE manufacturers introduced the Diesel Particulate Filter to reduce particle emissions. These are examples of these systems that retain the factory DPF.

#### Downpipe

These are examples of turbo downpipes designed for our exhaust systems but can also be use with the stock exhaust.

#### Racing System DPF-Delete

For serious racers, these are examples of exhaust systems that eliminate the factory DPF and CAT. These systems are designed for racing only and are not legal for street use.

#### Racing System DPF-Delete Pipe

Retaining most of the stock exhaust system, these DPF-Delete Pipe offer the option of eliminating just the restrictive DPF and/or the CAT. Stock flange fit up allow return to stock configuration when needed.



49-42009



49-42002



49-42006



49-42001



49-xxxxx



49-42022

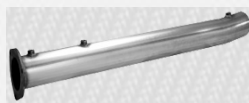

49-4300



49-43009



49-43006

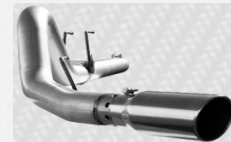

49-43025



49-xxxxx

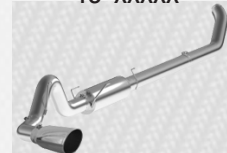

49-43024



49-44003



49-44001



49-44004



49-44020

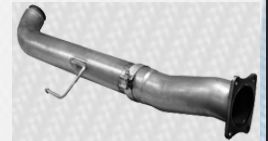

49-xxxxx



### Gas

#### Gas Truck

aFe offers exhaust systems not only for diesel trucks but also for gas trucks as well. Gas exhausts are all cat-back systems and are made of 409 Stainless Steel.

#### Gas Cars

In addition to gas truck exhaust systems, aFe offers exhaust systems for Dodges, BMWs, Jeeps, and Toyotas.

49-43011



49-42024



49-42013



49-46205



49-46008



49-46302

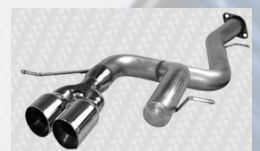



# aFe PRODUCT CATALOG

## Gamma Products

Multiple Directional Vane Technology

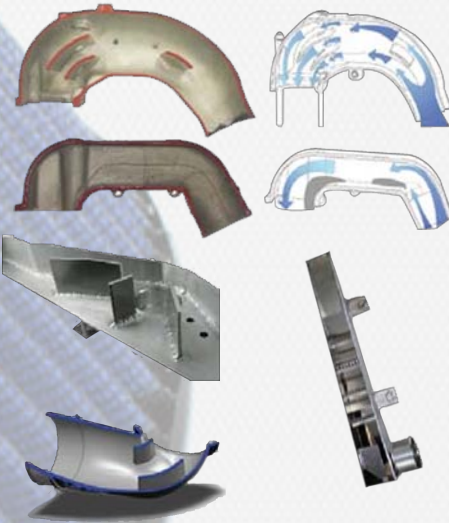

with



When any fluid flows around a sharp bend, turbulence and eddies create “dead” zones right after the bend, the faster the flow the greater the turbulence and eddies. These “dead air zones” restrict the effective dimension of the flow passage. MDV technology uses smooth bends and directional vanes to form multiple air paths through the manifold. These new paths are smoother and shorter, producing much smaller “dead air zones” for increased overall airflow to the engine.

### Charge Air Manifolds (P/N 46-100XX)



aFe Charge Air Manifolds incorporate MDV to improve airflow just before the air enters the engine. In addition to utilizing MDV, aFe manifolds have high arcs to reduce the sharpness of the angles. In addition, passages are enlarged to reduce resistance and improve airflow. For the serious performance enthusiasts, aFe offers threaded ports for sensors and auxillary inputs.

### Intercoolers (P/N 46-200XX)



MDV is utilized even in aFe intercoolers. Competitor intercoolers simply utilize thicker core or perhaps larger inlet and outlets. Without directional vanes, air flows along the most direct path between in the inlet and outlet. Often the full face of the intercooler is not used. However with MDV, the directional vanes that direct airflow along the tank so that air flows across the full face of the intercooler. With airflow across the intercooler, heat transfer occurs more effectively and lower air temperature is realized. aFe intercoolers have TIG-welded aluminum end tanks and 3” thick bar and plate core. The result is less restriction (<1 PSI) and lower EGTs (>100 °F).

### Turbo Inlet Tube (P/N 46-600XX)



Any improvement in airflow can have significant impact on horsepower and performance. aFe has developed an inlet tube utilizing MDV that attaches directly to the turbo. Casted of A356-T6 aluminum, these turbo inlet tubes increase airflow, speeds turbo spool up, lowers EGTs and improves MPG



# aFe PRODUCT CATALOG

## Gamma Products

### Exhaust Manifolds (P/N 46-400XX)

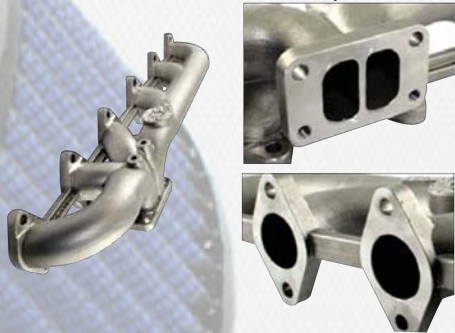

It has been known that the stock exhaust manifold on the Dodge 5.9L has a tendency to crack over time. To address this problem, aFe had developed an exhaust manifold casted of 304 stainless steel. This exhaust manifold is designed with thick wall (.25" vs .15" stock) for maximum durability. For improved airflow, aFe has incorporated a merged runner design. Finally, aFe has designed in reinforcing ribs and 2 EGT probe ports for measuring EGTs on each bank separately. The result is increased exhaust flow, faster turbo spool-up, lower EGTs and improved performance.

### Intercooler Tube Upgrades (P/N 46-200XX)



aFe's intercooler tube upgrades are design to replace the factory intercooler tube either on the cold side or the hot side. Even though larger in diameter, the upgrades follow a smoother course that requires no modification to the vehicle. Larger diameter and smoother flow path reducing resistance and improving airflow. In addition, these tube upgrades incorporate NPT fitting for sensors and auxillary input options.

### Differential Covers (P/N 46-700XX)



Made of A380-T6 die cast aluminum, aFe's rear differential cover have a 5 quart lube capacity compared to the stock 4 quart. This additional capacity ensure better heat dissipation and prolongs the life of the differential. Internal fins absorb heat from the lubricating fluid and transfers heat into the atmosphere more effectively through external fins. Included in the features are a magnetic drain plug that extend stick functions as an open filter and a calibration plug that approximates the stock cover fill plug. An oil level sight glass is included for easier maintenance.

### Throttle Body Spacers (P/N 46-300XX)



Precision-machined from solid T-6061 billet aluminum, these throttle body spacers utilize a combination serrated/helix design that create turbulence. The additional space provided by the spacer increases the volume between the throttle and cylinder improving volumetric efficiency. The combination serrated/helix design mixes the air and fuel thoroughly for a more complete burn. The surrated entry reduces annoying whistling sound at idle and cruising speeds.



# aFe PRODUCT CATALOG

## ProGUARD D2 Fluid Filters



P/N 44-nnXXX (nn=Type: FF=Fuel, LF=Oil, TF=Trans)  
 Anyone can design a filter with high efficiency. But only aFe's NF21 full-synthetic media achieves extreme efficiency without sacrificing flow. Built with a 3/8" inside nut/ratchet drive for easy removal, these filters are enclosed in heavy-duty 600 lb canisters. Heavy-duty coil spring and Nitrile rubber gasket prevent any leaks. NF21 synthetic composite material provide maximum engine protection with minimal flow restriction while a heavy-duty center tube provides for maximum flow. An anti-backflow valve is incorporated to reduce damage during cold starts. These fluid filters are heavy-duty and design for the rigors that a diesel truck encounters day to day.

## FULLMETAL *Power*

## Full Metal Power

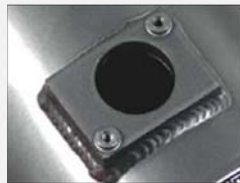

P/N F1-xxxxx = Full Metal Power - Diesel

F2-xxxxx = Full Metal Power - Gas

Full Metal Power is a new line of intake systems for gas and diesel truck owners that prefer a "shiny tube" that enhances the appearance of the engine compartment as much as performance. These intake system come with the ProDryS media filter. The tube has a polished gun metal gray finish. These system incorporate a heat shield that blocks some engine heat. With mounting bracket and MAF sensor pads incorporated into the system, these systems are easy to install and enhances the appearance of the engine compartment.