

BILLET

BILLET

# *BilletSpecialties*<sup>TM</sup>

DRIVING STYLE SINCE 1985

SPECIALTIES SPECIALTIES SPECIALTIES

VOL #30

# TABLE OF CONTENTS

## ENGINE ACCESSORIES

<b>Tru Trac Serpentine Systems</b>	
Chevrolet® SB, BB, 348/409, LS	4-17
Ford SB, BB, FE	18-25
Chrysler SB, BB, HEMI	26-31
Pontiac SB, BB	32-35
Upgrades & Add-ons	36-37
<b>V-Trac Pulley Systems</b>	
Chevrolet® SB, BB	38-39
Upgrades, Add-ons, & Accessories	40
<b>Tru Trac &amp; V-Trac Recommended Accessories</b>	41
<b>Serpentine Conversion Kits</b>	42-45
<b>Accessory Brackets</b>	46-47
<b>Independent Mount Brackets</b>	48-51
<b>Serpentine Pulleys</b>	52
<b>V-Groove Pulleys</b>	53-54
<b>Power Steering Components</b>	55-57
<b>Air Cleaners</b>	58-63
<b>Valve Covers</b>	64-71
<b>Engine Dress-Up Accessories</b>	
Breathers & PCV Breathers	72-73
Ignition Wire Organization	74-75
Engine Block Accessories	76-77
Cooling Components	78-79
Hose and Line Management	80-81
Battery Accessories	82
Hardware	83
<b>Hood and Deck Hinges</b>	84-87

Billet Specialties is not responsible for misprints. Prices are subject to change without notice. Prices do not include shipping, taxes, duties or customs charges.

## INTERIOR & EXTERIOR ACCESSORIES

<b>Pedals &amp; Pedal Kits</b>	88-93
<b>Door Panel Accessories</b>	94-96
<b>Dash Panel Accessories</b>	97
<b>Shift &amp; Column Accessories</b>	98-99
<b>Half-Wrap Steering Wheels</b>	100-111
<b>Horn Buttons &amp; Adapters</b>	112-113
<b>Mirrors</b>	114-116
<b>Lighting</b>	117-119
<b>Exterior Accessories</b>	120-121

## WHEELS

<b>Wheels</b>	122-165
<b>Wheel Accessories</b>	166
<b>Measuring Guide</b>	167-168

## WARRANTY & RETURN POLICY

<b>Return Policy</b>	169
----------------------	-----



"Lakeside Rods uses Billet Specialties products on every car we build. Precision quality and fit every time"

- ROGER BURMAN - LAKESIDE RODS & RIDES

- 2012 SEMA Mothers Shine Award
- 2012 Goodguys Muscle Machine of the Year
- 2007 America's Most Beautiful Roadster
- 2006 Ridler Award
- 2004 Goodguys Custom Rod of the Year

**AMERICAN MADE QUALITY** first and foremost. Billet Specialties has been on the forefront of manufacturing billet aluminum wheels and accessories since 1985. With the most diverse lineup of products in the industry, Billet Specialties has become the go-to manufacturer that top builders use and trust. This recognition comes from years of experience, enthusiasm and innovation conceived into each and every product, instruction sheet and product package.

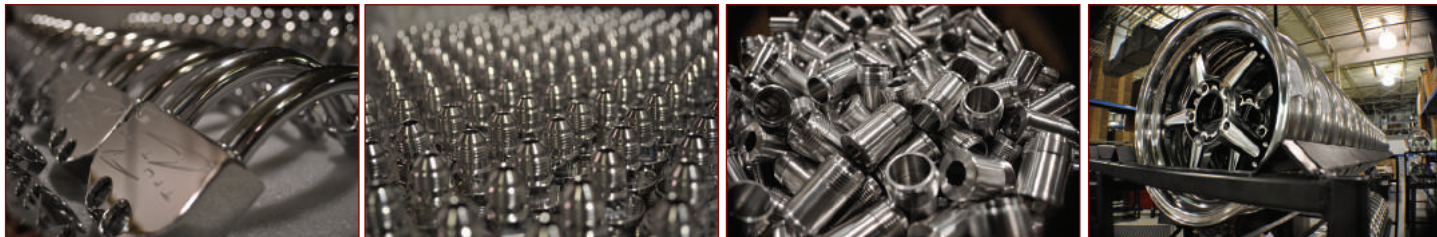

*"Every time I come up here, I challenge these guys and every time I challenge them - it comes out better. Everything is done in house, from concept to reality. Their quality and design is irreplaceable and that is why I choose Billet Specialties"*

**- Troy Trepanier - RAD RIDES BY TROY**

- 2007 Ridler Award
- 1998 Goodguys Custom Rod of the Year
- 2002 Goodguys Street Machine of the Year
- 2008 Goodguys Muscle Machine of the Year
- 2004 Goodguys Street Rod of the Year
- 2002, 2004 & 2012 Mothers Shine Award
- 2002 & 2012 SEMA GM Design Award
- 2007 Grand National Roadster Show Builder of the Year
- 2014 America's most beautiful roadster
- 2014 Detroit Autorama builder of the year



2013 Goodguys Street Machine of the Year



*"Our cars are built to drive coast to coast. We have been relying on Billet Specialties quality for over 15 years. Everything they make performs as good as it looks!"*

**-Roy Brizio**



"Stance, tires and wheels define the trademark Alloway look. Billet Specialties is the go to manufacturer of choice, their quality and delivery is second to none"



*"Billet Specialties attention to detail is unmatched in the industry. With over 40 years in the racing engine business, Billet Specialties products are some of the very few that do not need to be re-machined or re-engineered to make everything work"*

**- JON KAASE – KAASE RACING ENGINES**



*"Customer service and quality of parts every time, and the only serpentine kits offered that truly bolt on, fit and work perfect!"*

**- SCOTT BONOWSKI – HOT RODS & HOBBIES**

- 2006 & 2009 Worlds Most Beautiful Custom - Fresno Autorama
- 2011 Grand National Roadster Show Builder of the Year
- 2009 Triple Gun of Excellence Award Grand National Roadster Show



# CHEVROLET® TRU TRAC KITS

SMALL BLOCK, BIG BLOCK, 348/409



"Top notch hardware, Quality components, compact design and professional engineering. You cannot beat the Tru Trac"

- RAD RIDES BY TROY

## BILLET A/C MANIFOLD

Kits with AC include our billet aluminum AC manifold, engineered not only to provide an efficient attachment point for the AC hoses, but to look good as well. In fact, so good and efficient we patented it!

## BILLET TENSIONER

Our billet aluminum tensioner optimizes belt and accessory life with constant and correct tension; eliminating belt-slip while minimizing parasitic horsepower loss. Every modern car has a tensioner—so should your classic.

## DURABILITY

Pulleys that are in contact with the back of the belt are subject to high wear. Billet Specialties hard coat anodizes these areas to eliminate wear altogether. Hard coat anodized aluminum actually provides a harder surface than stock steel pulleys!

## STAINLESS STANDOFFS

Our stainless stand-offs provide the most rigid platform in the industry, while maintaining perfect alignment between the accessories. Machined from 303 stainless steel to provide corrosion resistance and double the surface area while adding ease of assembly.



## FASTENERS

Tru Trac kits are assembled with 18-8 stainless steel fasteners, offering not only corrosion resistance, but professional appearance and high tensile strength. ARP 12pt. fasteners also match many other Billet Specialties accessories.

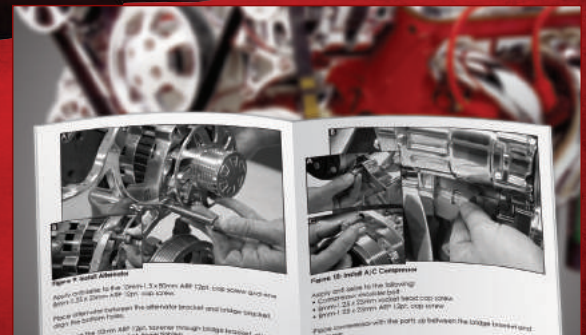

## EASE OF INSTALLATION

With our comprehensive instruction booklet and pre-installed alternator and power steering pulleys, installing a Tru Trac is easy.

## THE BEST BRANDS INCLUDED!



Designed and cast in the USA, Edelbrock water pumps provide maximum flow, maximum pressure and equal distribution to both sides of the block within 1%. Featuring Edelbrock's industry leading precision powdered metal impeller with modern vane design that is larger than other high-performance pumps along with the precision machined computer designed A-356 cast pump housing.

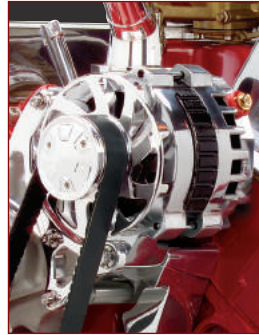

Billet Specialties supplies a new 140 amp Powermaster alternator in every Tru Trac kit. Each Powermaster alternator is 100% new. With a high amp output at idle, internally regulated architecture and internal fan with a gold plated battery post. Each 140 amp alternator is pre-tested and includes a proof of performance tag showing output at idle and at highway speeds. Best of all, Powermaster alternators are made right here in the USA.



Sanden manufactures and supplies compressors for some of the largest automotive manufacturers in the world. The SD-7 is a high efficiency modern compact compressor ensuring better performance and aesthetics over early 508 compressors while keeping you cool and comfortable.

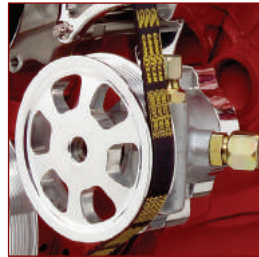

Kits with power steering feature modern TC style pumps, used by OEM manufacturers and various applications from NASCAR, Off Road and Road Racing. We supply the pumps with -10AN supply and -6AN pressure nipples installed. Featuring a sealed front bearing and precision internals, each high performance pump is calibrated to 1200 PSI and flows at 3.5 GPM.

## STANDARD POLISHED AND BLACK ANODIZED KITS INCLUDE:

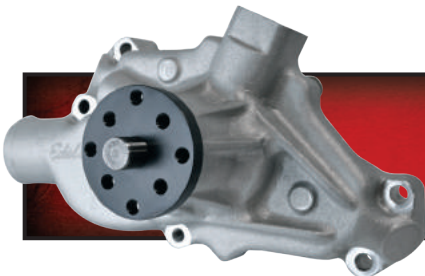

### Natural Finish Water Pump

The traditional look of performance for decades, the natural cast look easily matches your cast intake manifold and power steering pump.



### Polished 140 amp Alternator

Powermaster USA made quality, precision cast and polished case with the best internal components in the industry.

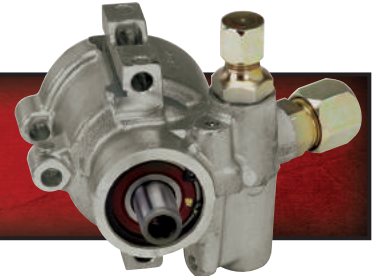

### Natural Finish Power Steering Pump

Matches the natural finish Edelbrock water pump and we pre-install the pulley for ease of installation.

## PREMIUM KITS INCLUDE:

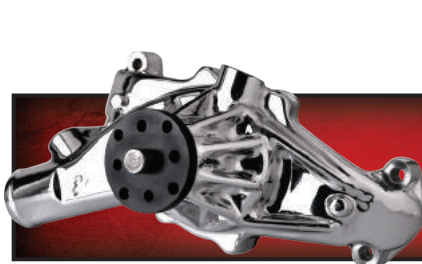

### EnduraShine™ Water Pump

EnduraShine is a bright chrome like vacuum metallized finish that matches our polished billet aluminum components.



### Optional Billet Aluminum 140 amp Alternator

Truly the crown jewel of the Premium kit. The precision machined 6061-T6 billet case makes this the ultimate alternator.

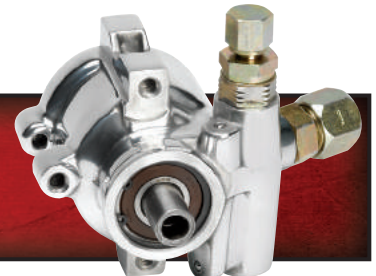

### Polished Power Steering Pump

Show quality polish and pre-installed pulley for ease of installation.

# CHEVROLET® SMALL BLOCK

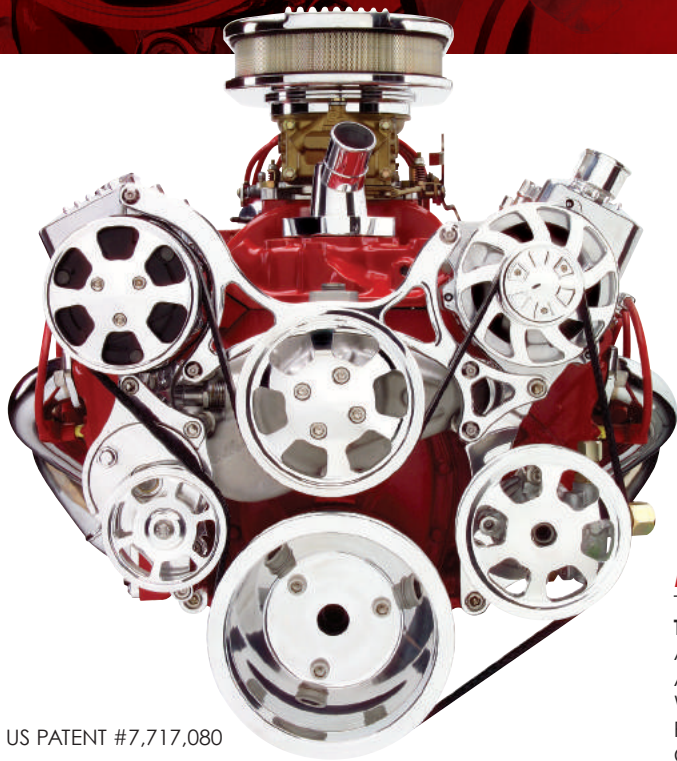

US PATENT #7,717,080

#### All Kits Feature:

- Exclusive billet aluminum tensioner
- Polished ARP 12-point stainless steel fasteners
- Hard-coat anodizing for durability in high-wear areas
- Continental Elite serpentine belt
- Comprehensive instruction manual

\*Tru Trac systems are not designed for use with hydroboost brake systems\*

## BIG STYLE FOR YOUR SMALL BLOCK

The Tru Trac for small block Chevrolet® patented design mounts between the water pump and the engine block via positive O-ring seal. It works with all cylinder head configurations. Early model, late model, or Vortec™ - Tru Trac fits them all.

Featuring the best brands in aftermarket performance:



NOW 140 AMP!



## DIMENSIONS - SMALL BLOCK CHEVY™

To Front Face Of	From Block Face
AC Compressor Cover	7.437"
Alternator Pulley	6.500"
Water Pump Pulley	7.000"
Power Steering Pulley	6.312"
Crankshaft Pulley	6.187"

A: 8.375"	D: 7.000"
B: 8.750"	E: 9.000"
C: 6.625"	

\* Check Clearances Before Ordering \*

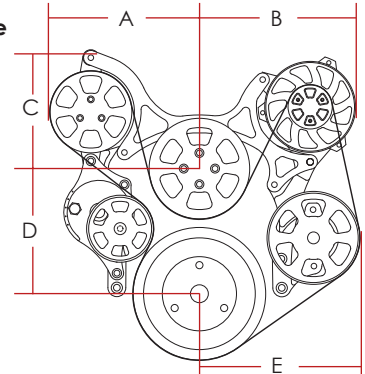

## STANDARD POLISHED KITS

Standard polished Small Block Chevrolet® Tru Trac includes the following:

- Polished aluminum pulleys & brackets
- Polished billet tensioner (Tru Trac exclusive)
- Polished 140 amp Powermaster 1-wire alternator
- Natural finish Edelbrock reverse rotation water pump

#### Kits with AC Include:

- Polished Sanden SD-7 compressor
- Polished AC clutch cover
- Patented polished billet compressor manifold

#### Kits with power steering include:

- Natural finish power steering pump with AN nipples
- Polished power steering pulley installed



With AC  
With Power Steering  
#13220



With AC  
Without Power Steering  
#13120



Without AC  
With Power Steering  
#13225



Without AC  
Without Power Steering  
#13125

# PREMIUM KITS



Premium Small Block Chevrolet® Tru Trac includes the following:

- Polished aluminum pulleys & brackets
- Polished billet tensioner (Tru Trac exclusive)
- Polished 140 amp Powermaster 1-wire alternator or polished billet machined case 140 amp alternator
- EnduraShine™ Edelbrock reverse rotation water pump

**Kits with AC include:**

- Polished Sanden SD-7 compressor
- Polished AC clutch cover
- Patented polished billet compressor manifold

**Kits with power steering include:**

- Polished finish power steering pump with AN nipples
- Polished power steering pulley installed



**With AC  
With Power Steering**

With EnduraShine™ Water Pump & Polished P/S Pump  
#13220WP

With EnduraShine™ Water Pump  
Polished P/S Pump  
Polished 140 Amp Billet Alternator  
#13220WPA



**With AC  
Without Power Steering**

With EnduraShine™ Water Pump  
#13120W

With EnduraShine™ Water Pump  
Polished 140 Amp Billet Alternator  
#13120WA



**Without AC  
With Power Steering**

With EnduraShine™ Water Pump & Polished P/S Pump  
#13225WP

With EnduraShine™ Water Pump  
Polished P/S Pump  
Polished 140 Amp Billet Alternator  
#13225WPA



**Without AC  
Without Power Steering**

With EnduraShine™ Water Pump  
#13125W

With EnduraShine™ Water Pump  
Polished 140 Amp Billet Alternator  
#13125WA

# PREMIUM BLACK ANODIZED KITS

With EnduraShine™ Water Pump & Polished P/S Pump  
#BLK13220WP

With EnduraShine™ Water Pump, Polished P/S Pump & Polished 140 Amp Billet Alternator  
#BLK13220WPA

*\* Includes all the upgrades from the premium kits above, with black anodized pulleys, brackets, and tensioner\**

# BLACK ANODIZED KITS

Black anodized Small Block Chevrolet® Tru Trac includes the following:

- Black anodized aluminum pulleys & brackets
- Black anodized billet tensioner (Tru Trac exclusive)
- Polished 140 amp Powermaster 1-wire alternator
- Natural finish Edelbrock reverse rotation water pump

**Kits with AC include:**

- Polished Sanden SD-7 compressor
- Black anodized AC clutch cover
- Patented black anodized billet compressor manifold

**Kits with power steering include:**

- Natural finish power steering pump with AN nipples
- Black anodized power steering pulley installed

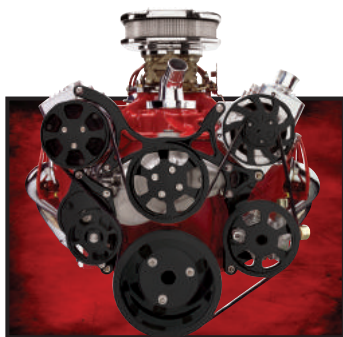

**With AC  
With Power Steering**  
#BLK13220



**With AC  
Without Power Steering**  
#BLK13120



**Without AC  
With Power Steering**  
#BLK13225



**Without AC  
Without Power Steering**  
#BLK13125

# CHEVROLET® BIG BLOCK



US PATENT #7,717,080

#### All Kits Feature:

- Exclusive billet aluminum tensioner
- Polished ARP 12-point stainless steel fasteners
- Hard-coat anodizing for durability in high-wear areas
- Continental Elite serpentine belt
- Comprehensive instruction manual

\*Tru Trac systems are not designed for use with hydroboost brake systems\*

## THE BEST YOUR BIG BLOCK HAS EVER LOOKED...

There is no substitute for big block horsepower and torque - the efficiency of a Tru Trac system ensures you get the most out of your motor. Engineered to fit any cylinder head and manifold configuration, the big block Tru Trac's exclusive billet aluminum tensioner keeps constant even tension allowing the 140 amp alternator and Edelbrock water pump to run at full potential without fear of belt slip. The compact design fits easily into the tightest engine compartments truly making it the ultimate serpentine system.

Featuring the best brands in aftermarket performance:



NOW 140 AMP!



## DIMENSIONS - BIG BLOCK CHEVY™

To Front Face Of	From Block Face
AC Compressor Cover	7.562"
Alternator Pulley	6.625"
Water Pump Pulley	7.125"
Power Steering Pulley	6.437"
Crankshaft Pulley	6.375"

A: 9.125"	D: 7.125"
B: 9.250"	E: 9.500"
C: 7.250"	

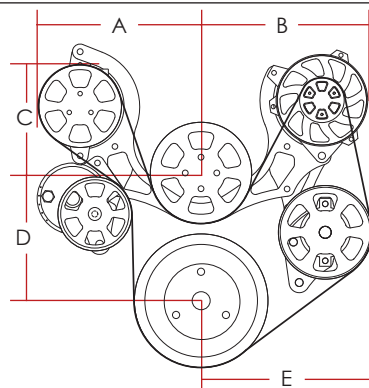

\* Check Clearances Before Ordering \*

## STANDARD POLISHED KITS

Standard polished Big Block Chevrolet® Tru Trac includes the following:

- Polished aluminum pulleys & brackets
- Polished billet tensioner (Tru Trac exclusive)
- Polished 140 amp Powermaster 1-wire alternator
- Natural finish Edelbrock reverse rotation water pump

#### Kits with AC Include:

- Polished Sanden SD-7 compressor
- Polished AC clutch cover
- Patented polished billet compressor manifold

#### Kits with power steering include:

- Natural finish power steering pump with AN nipples
- Polished power steering pulley installed



With AC  
With Power Steering  
#14220



With AC  
Without Power Steering  
#14120



Without AC  
With Power Steering  
#14225

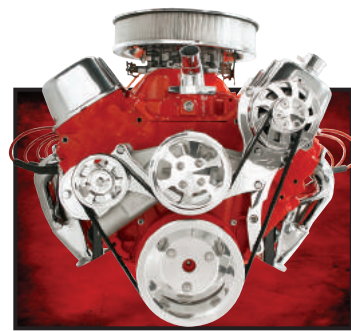

Without AC  
Without Power Steering  
#14125



# PREMIUM KITS



Premium Big Block Chevrolet® Tru Trac includes the following:

- Polished aluminum pulleys & brackets
- Polished billet tensioner (Tru Trac exclusive)
- Polished 140 amp Powermaster 1-wire alternator or polished billet machined case 140 amp alternator
- EnduraShine™ Edelbrock reverse rotation water pump

**Kits with AC include:**

- Polished Sanden SD-7 compressor
- Polished AC clutch cover
- Patented polished billet compressor manifold

**Kits with power steering include:**

- Polished finish power steering pump with AN nipples
- Polished power steering pulley installed



**With AC  
With Power Steering**

With EnduraShine™ Water Pump & Polished P/S Pump  
#14220WP

With EnduraShine™ Water Pump Polished P/S Pump Polished 140 Amp Billet Alternator  
#14220WPA



**With AC  
Without Power Steering**

With EnduraShine™ Water Pump  
#14120W

With EnduraShine™ Water Pump Polished 140 Amp Billet Alternator  
#14120WA

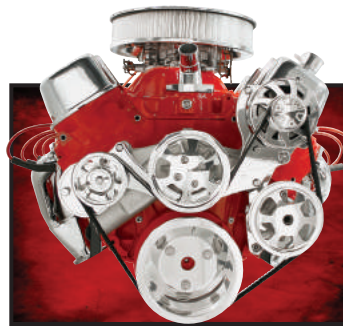

**Without AC  
With Power Steering**

With EnduraShine™ Water Pump & Polished P/S Pump  
#14225WP

With EnduraShine™ Water Pump Polished P/S Pump Polished 140 Amp Billet Alternator  
#14225WPA

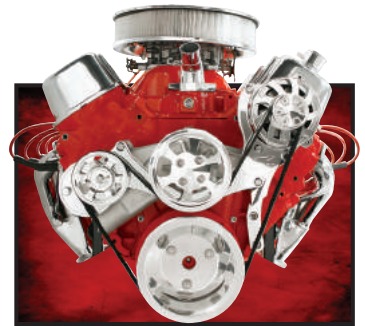

**Without AC  
Without Power Steering**

With EnduraShine™ Water Pump  
#14125W

With EnduraShine™ Water Pump Polished 140 Amp Billet Alternator  
#14125WA

# PREMIUM BLACK ANODIZED KITS

With EnduraShine™ Water Pump & Polished P/S Pump  
#BLK14220WP

With EnduraShine™ Water Pump, Polished P/S Pump & Polished 140 Amp Billet Alternator  
#BLK14220WPA

*\* Includes all the upgrades from the premium kits above, with black anodized pulleys, brackets, and tensioner.*

# BLACK ANODIZED KITS

Black anodized Big Block Chevrolet® Tru Trac includes the following:

- Black anodized aluminum pulleys & brackets
- Black anodized billet tensioner (Tru Trac exclusive)
- Polished 140 amp Powermaster 1-wire alternator
- Natural finish Edelbrock reverse rotation water pump

**Kits with AC include:**

- Polished Sanden SD-7 compressor
- Black anodized AC clutch cover
- Patented black anodized billet compressor manifold

**Kits with power steering include:**

- Natural finish power steering pump with AN nipples
- Black anodized power steering pulley installed



**With AC  
With Power Steering**  
#BLK14220



**With AC  
Without Power Steering**  
#BLK14120



**Without AC  
With Power Steering**  
#BLK14225



**Without AC  
Without Power Steering**  
#BLK14125

# CHEVROLET® 348/409

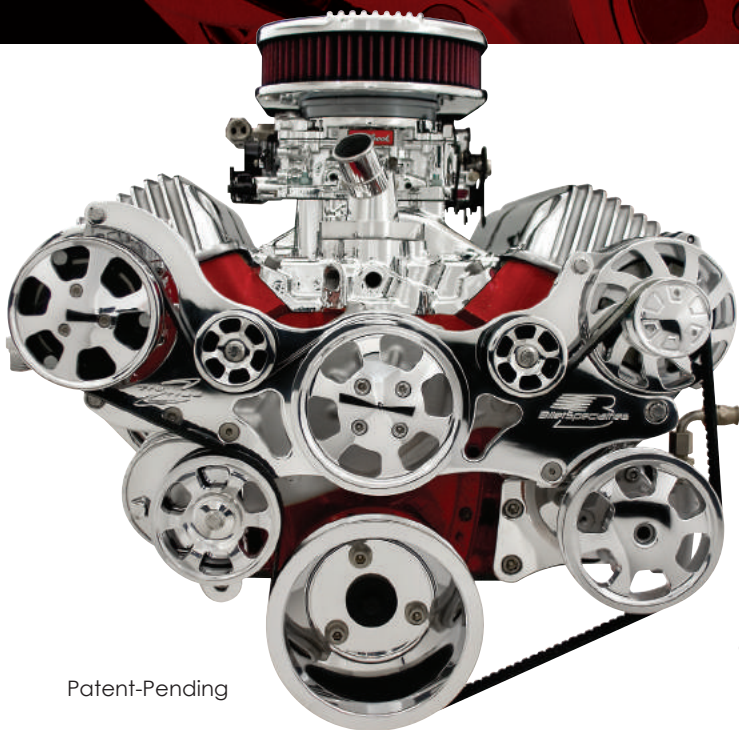

Patent-Pending

### All Kits Feature:

- Exclusive billet aluminum tensioner
- Polished ARP 12-point stainless steel fasteners
- Hard-coat anodizing for durability in high-wear areas
- Continental Elite serpentine belt
- Comprehensive instruction manual

\*Tru Trac systems are not designed for use with hydroboost brake systems\*

## A LEGEND GETS A FACELIFT

It was feared on the drag strips and boulevards across America. Its monster torque punished the asphalt. It was the first production big block. It was immortalized in a song, and in only seven years of production the 348/409 became a legend. Take your legend to the next level with a Tru Trac kit featuring modern true serpentine performance, compact profile and timeless style.

Featuring the best brands in aftermarket performance:



NOW 140 AMP!



## DIMENSIONS - BIG BLOCK CHEVY™

To Front Face Of	From Block Face
AC Compressor Cover	7.625"
Alternator Pulley	6.750"
Water Pump Pulley	7.125"
Power Steering Pulley	6.625"
Crankshaft Pulley	6.500"

- A: 11.25"
- B: 11.75"
- C: 6.25"
- D: 7.125"
- E: 11.125"

\* Check Clearances Before Ordering \*

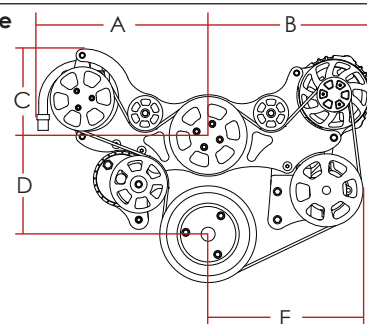

Note: Some 348 blocks do not have the lower bosses threaded and may require modification. Please check your engine block before ordering.

## STANDARD POLISHED KITS

Standard polished 348/409 Chevrolet® Tru Trac includes the following:

- Polished aluminum pulleys & brackets
- Polished billet tensioner (Tru Trac exclusive)
- Polished 140 amp Powermaster 1-wire alternator
- Natural finish Edelbrock reverse rotation water pump

### Kits with AC Include:

- Polished Sanden SD-7 compressor
- Polished AC clutch cover
- Patented polished billet compressor manifold

### Kits with power steering include:

- Natural finish power steering pump with AN nipples
- Polished power steering pulley installed



With AC  
With Power Steering  
#14400



With AC  
Without Power Steering  
#14420



Without AC  
With Power Steering  
#14405

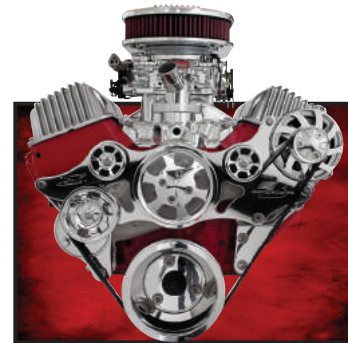

Without AC  
Without Power Steering  
#14425

# PREMIUM KITS



Premium 348/409 Chevrolet® Tru Trac includes the following:

- Polished aluminum pulleys & brackets
- Polished billet tensioner (Tru Trac exclusive)
- Polished 140 amp Powermaster 1-wire alternator or polished billet machined case 140 amp alternator
- EnduraShine™ Edelbrock reverse rotation water pump

**Kits with AC include:**

- Polished Sanden SD-7 compressor
- Polished AC clutch cover
- Patented polished billet compressor manifold

**Kits with power steering include:**

- Polished finish power steering pump with AN nipples
- Polished power steering pulley installed



**With AC  
With Power Steering**

With EnduraShine™ Water Pump & Polished P/S Pump  
#14400WP

With EnduraShine™ Water Pump Polished P/S Pump Polished 140 Amp Billet Alternator  
#14400WPA



**With AC  
Without Power Steering**

With EnduraShine™ Water Pump  
#14420W

With EnduraShine™ Water Pump Polished 140 Amp Billet Alternator  
#14420WA



**Without AC  
With Power Steering**

With EnduraShine™ Water Pump & Polished P/S Pump  
#14405WP

With EnduraShine™ Water Pump Polished P/S Pump Polished 140 Amp Billet Alternator  
#14405WPA



**Without AC  
Without Power Steering**

With EnduraShine™ Water Pump  
#14425W

With EnduraShine™ Water Pump Polished 140 Amp Billet Alternator  
#14425WA

# PREMIUM BLACK ANODIZED KITS

With EnduraShine™ Water Pump & Polished P/S Pump  
#BLK14400WP

With EnduraShine™ Water Pump, Polished P/S Pump & Polished 140 Amp Billet Alternator  
#BLK14400WPA

*\* Includes all the upgrades from the premium kits above, with black anodized pulleys, brackets, and tensioner\**

# BLACK ANODIZED KITS

Black anodized 348/409 Chevrolet® Tru Trac includes the following:

- Black anodized aluminum pulleys & brackets
- Black anodized billet tensioner (Tru Trac exclusive)
- Polished 140 amp Powermaster 1-wire alternator
- Natural finish Edelbrock reverse rotation water pump

**Kits with AC include:**

- Polished Sanden SD-7 compressor
- Black anodized AC clutch cover
- Patented black anodized billet compressor manifold

**Kits with power steering include:**

- Natural finish power steering pump with AN nipples
- Black anodized power steering pulley installed



**With AC  
With Power Steering  
#BLK14400**

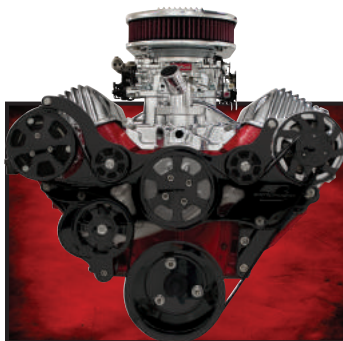

**With AC  
Without Power Steering  
#BLK14420**



**Without AC  
With Power Steering  
#BLK14405**



**Without AC  
Without Power Steering  
#BLK14425**

# CHEVROLET® TRU TRAC KITS

LS 1, 2, 3, 6, 7

## BILLET A/C MANIFOLD

Kits with AC include our billet aluminum AC manifold, engineered not only to provide an efficient attachment point for the AC hoses, but to look good as well. In fact, so good and efficient we patented it!

## DURABILITY

Pulleys that are in contact with the back of the belt are subject to high wear. Billet Specialties hard coat anodizes these areas to eliminate wear altogether. Hard coat anodized aluminum actually provides a harder surface than stock steel pulleys!

## BILLET TENSIONER

Our billet aluminum tensioner optimizes belt and accessory life with constant and correct tension; eliminating belt-slip while minimizing parasitic horsepower loss. Every modern car has a tensioner—so should your classic.

## STAINLESS STANDOFFS

Our stainless stand-offs provide the most rigid platform in the industry, while maintaining perfect alignment between the accessories. Machined from 303 stainless steel to provide corrosion resistance and double the surface area while adding ease of assembly.



## FASTENERS

Tru Trac Kits are assembled with 18-8 stainless steel fasteners, offering not only corrosion resistance, but professional appearance and high tensile strength. ARP 12pt. fasteners also match many other Billet Specialties accessories.



## EASE OF INSTALLATION

With our comprehensive instruction booklet and pre-installed alternator and power steering pulleys, installing a Tru Trac is easy.

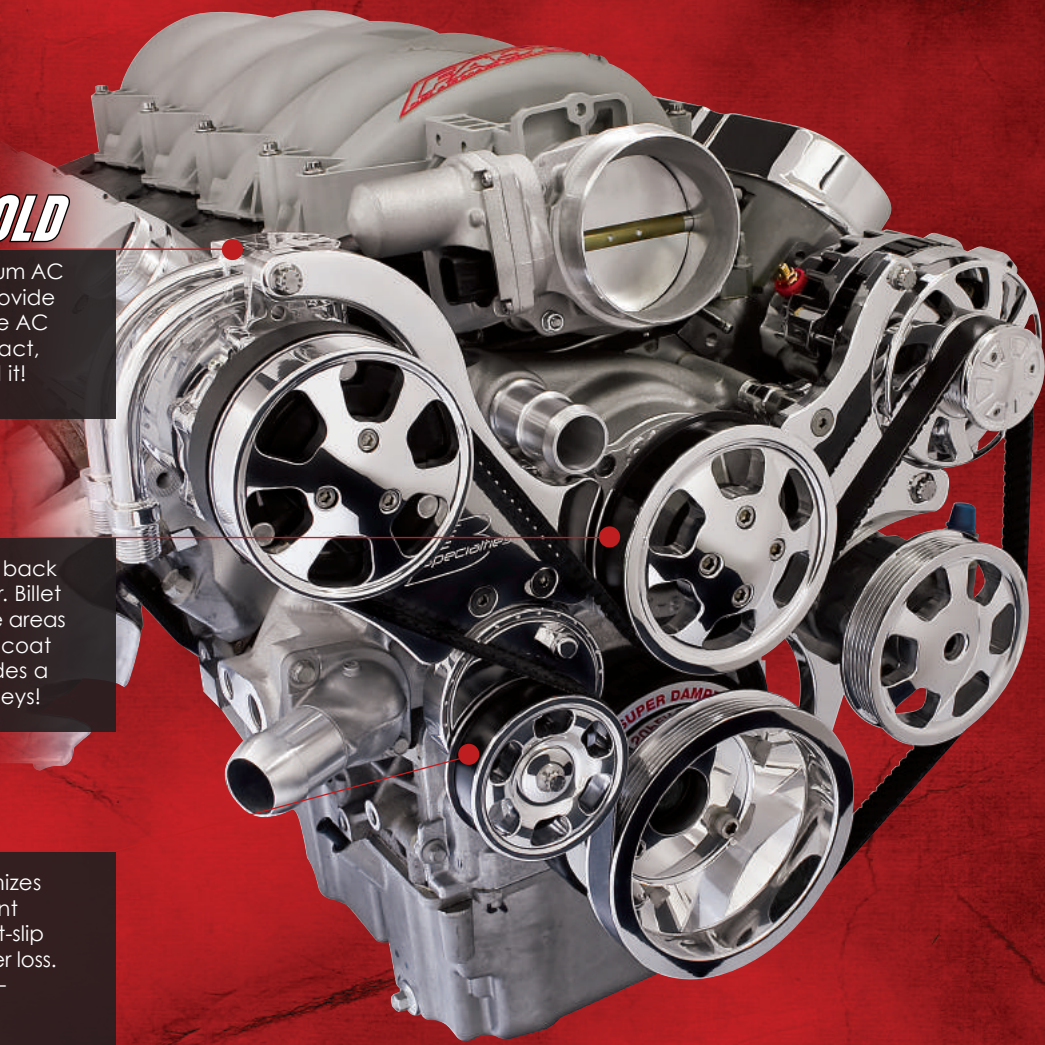
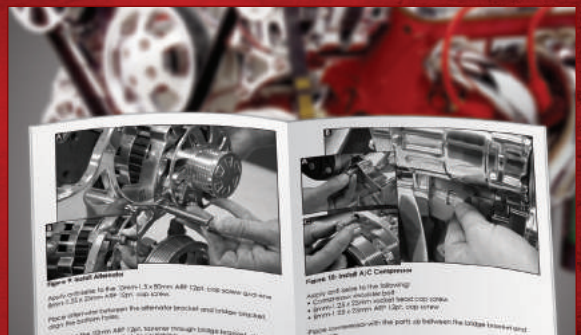



## THE BEST BRANDS INCLUDED!

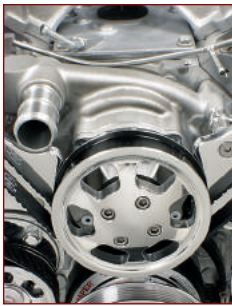

Designed and cast in the USA, Edelbrock water pumps provide maximum flow, maximum pressure and equal distribution to both sides of the block within 1%. Featuring Edelbrock's industry leading precision powered metal impeller with modern vane design that is larger than other high-performance pumps along with the precision machined computer designed A-356 Cast pump housing.

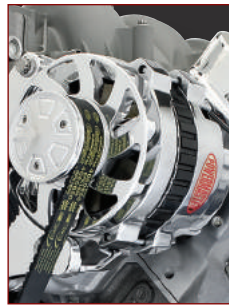

Billet Specialties supplies a new 140 amp Powermaster alternator in every Tru Trac kit. Each Powermaster alternator is 100% new. With a high amp output at idle, internally regulated architecture and internal fan with a gold plated battery post. Each 140 amp alternator is pre-tested and includes a proof of performance tag showing output at idle and at highway speeds. Best of all, Powermaster alternators are made right here in the USA.



Sanden manufactures and supplies compressors for some of the largest automotive manufacturers in the world. The SD-7 is a high efficiency modern compact compressor ensuring better performance and aesthetics over early 508 compressors while keeping you cool and comfortable.

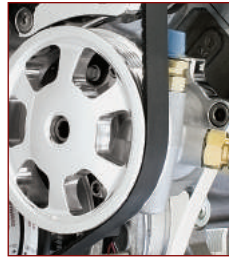

Kits with power steering feature modern TC style pumps, used by OEM manufacturers and various applications from NASCAR, Off Road and Road Racing. We supply the pumps with -10AN supply and -6AN pressure nipples installed. Featuring a sealed front bearing and precision internals, each high performance pump is calibrated to 1200 PSI and flows at 3.5 GPM.



Top mount LS kits include an ATI Super Damper. ATI has been manufacturing quality products for over 50 years and can be found on race winning vehicles worldwide and on GM performance crate motors. The ATI damper exceeds SFI 18.1 specs while eliminating torsional crankshaft vibrations.

## STANDARD POLISHED AND BLACK ANODIZED KITS INCLUDE:

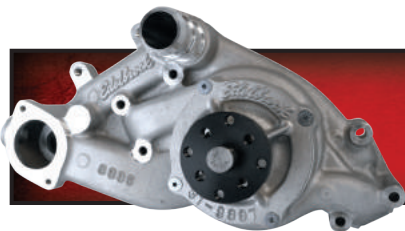

### Natural Finish Water Pump

The traditional look of performance for decades, the natural cast look easily matches your cast intake manifold and power steering pump.



### Polished 140 amp Alternator

Powermaster USA made quality, precision cast and polished case with the best internal components in the industry.

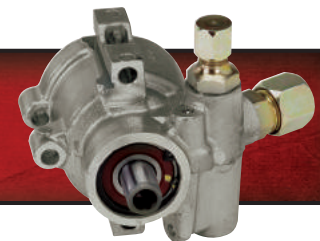

### Natural Finish Power Steering Pump

Matches the natural finish Edelbrock water pump and we pre-install the pulley for ease of installation.

## PREMIUM KITS INCLUDE:



### Natural Finish Water Pump

The traditional look of performance for decades, the natural cast look easily matches your cast intake manifold and power steering pump.

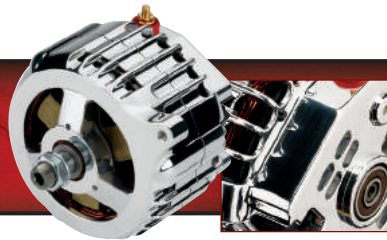

### Optional Billet Aluminum 140 amp Alternator

Truly the crown jewel of the Premium kit. The precision machined 6061-T6 billet case makes this the ultimate alternator.

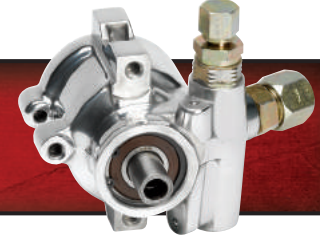

### Polished Power Steering Pump

Show quality polish and pre-installed pulley for ease of installation.

# CHEVROLET® LS1, 2, 3, 6, LSX

TOP MOUNT CONFIGURATION



Patent-Pending

#### All Kits Feature:

- Exclusive billet aluminum tensioner
- Polished ARP 12-point stainless steel fasteners
- Hard-coat anodizing for durability in high-wear areas
- Continental Elite serpentine belt
- Comprehensive instruction manual

\*Tru Trac systems are not designed for use with hydroboost brake systems\*

#### HIGH TECH. HIGH PERFORMANCE.

The LS platform has become the go-to engine for Chevy enthusiasts and keeping pace is Billet Specialties Top Mount LS Tru Trac. Engineered to clear cross members and steering boxes of muscle cars all the while keeping a slim profile, the LS top mount kit includes all the essentials for a complete engine accessory drive. The Tru Trac's exclusive billet aluminum tensioner keeps constant even tension allowing the 140 amp alternator and Edelbrock water pump to run at full potential without fear of belt slippage.

Featuring the best brands in aftermarket performance:



NOW 140 AMP!



#### DIMENSIONS - TOP MOUNT LS CHEVY™

To Front Face Of	From Block Face
AC Compressor Cover	7.625"
Alternator Pulley	6.750"
Water Pump Pulley	7.000"
Power Steering Pulley	6.625"
Crankshaft Pulley	6.500"

A: 12.00"	D: 9.125"
B: 10.50"	E: 5.00"
C: 7.75"	

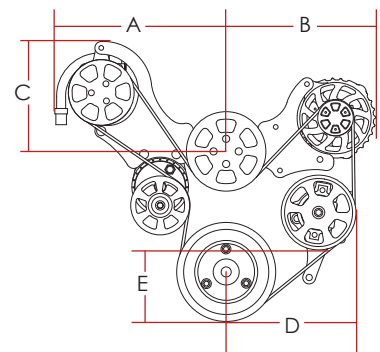

\* Check Clearances Before Ordering \*  
\* Will not work with VVT engines \*

## STANDARD POLISHED KITS

Standard polished Top Mount LS1, 2, 3, 6, LSX Chevrolet® Tru Trac includes the following:

- Polished aluminum pulleys & brackets
- Polished billet tensioner (Tru Trac exclusive)
- Polished 140 amp Powermaster 1-wire alternator
- Natural finish Edelbrock reverse rotation water pump

#### Kits with AC Include:

- Polished Sanden SD-7 compressor
- Polished AC clutch cover
- Patented polished billet compressor manifold

#### Kits with power steering include:

- Natural finish power steering pump with AN nipples
- Polished power steering pulley installed



With AC  
With Power Steering  
#13450



With AC  
Without Power Steering  
#13470



Without AC  
With Power Steering  
#13455

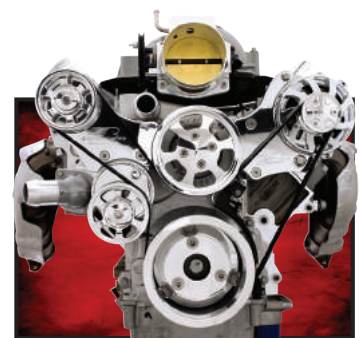

Without AC  
Without Power Steering  
#13475

# PREMIUM KITS



Premium Top Mount LS1, 2, 3, 6, LSX Chevrolet® Tru Trac includes the following:

- Polished aluminum pulleys & brackets
- Polished billet tensioner (Tru Trac exclusive)
- Polished 140 amp Powermaster 1-wire alternator or polished billet machined case 140 amp alternator
- Natural finish Edelbrock reverse rotation water pump

**Kits with AC include:**

- Polished Sanden SD-7 compressor
- Polished AC clutch cover
- Patented polished billet compressor manifold

**Kits with power steering include:**

- Polished finish power steering pump with AN nipples
- Polished power steering pulley installed



**With AC  
With Power Steering**

With Polished P/S Pump

**#13450P**

With Polished P/S Pump  
Polished 140 Amp  
Billet Alternator

**#13450PA**



**With AC  
Without Power Steering**

With Polished 140 Amp  
Billet Alternator

**#13470A**

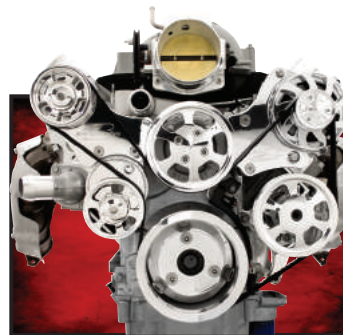

**Without AC  
With Power Steering**

With Polished P/S Pump

**#13455P**

With Polished P/S Pump  
Polished 140 Amp  
Billet Alternator

**#13455PA**

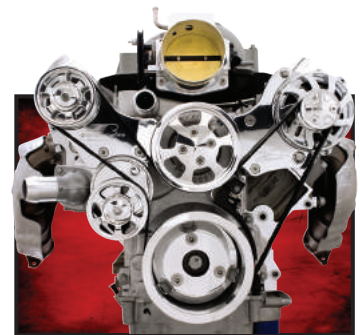

**Without AC  
Without Power Steering**

With Polished 140 Amp  
Billet Alternator

**#13475A**

# PREMIUM BLACK ANODIZED KITS

With Polished P/S Pump

**#BLK13450P**

With Polished P/S Pump & Polished  
140 Amp Billet Alternator

**#BLK13450PA**

*\* Includes all the upgrades from the premium kits above, with black anodized pulleys, brackets, and tensioner\**

# BLACK ANODIZED KITS

Black anodized Top Mount LS1, 2, 3, 6, LSX Chevrolet® Tru Trac includes the following:

- Black anodized aluminum pulleys & brackets
- Black anodized billet tensioner (Tru Trac exclusive)
- Polished 140 amp Powermaster 1-wire alternator
- Natural finish Edelbrock reverse rotation water pump

**Kits with AC include:**

- Polished Sanden SD-7 compressor
- Black anodized AC clutch cover
- Patented black anodized billet compressor manifold

**Kits with power steering include:**

- Natural finish power steering pump with AN nipples
- Black anodized power steering pulley installed



**With AC  
With Power Steering**

**#BLK13450**

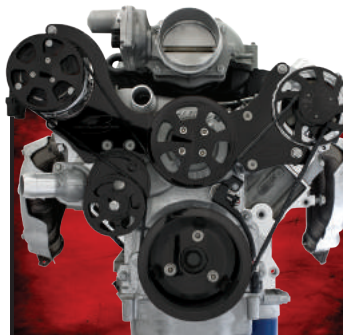

**With AC  
Without Power Steering**

**#BLK13470**

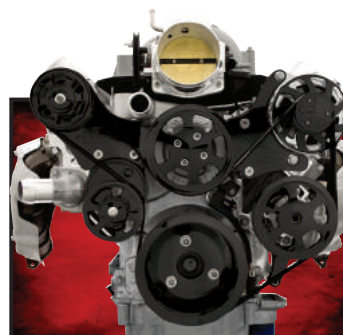

**Without AC  
With Power Steering**

**#BLK13455**

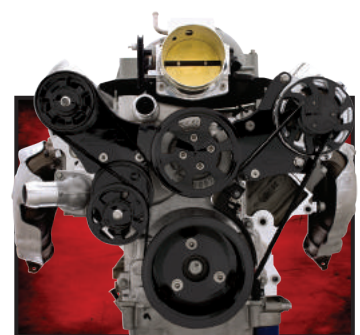

**Without AC  
Without Power Steering**

**#BLK13475**

# CHEVROLET® LS7

## TOP MOUNT CONFIGURATION

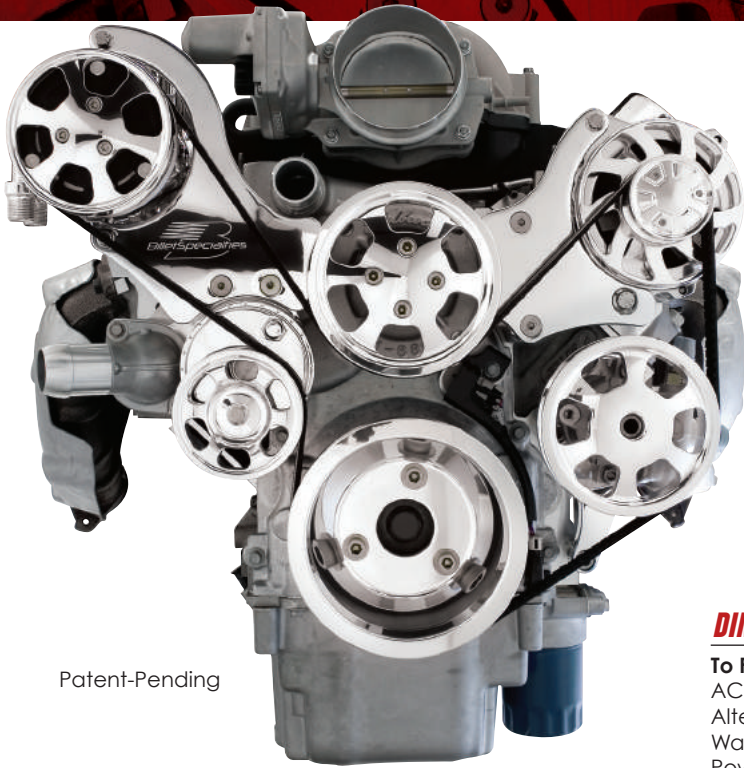

Patent-Pending

### All Kits Feature:

- Exclusive billet aluminum tensioner
- Polished ARP 12-point stainless steel fasteners
- Hard-coat anodizing for durability in high-wear areas
- Continental Elite serpentine belt
- Comprehensive instruction manual

\*Tru Trac systems are not designed for use with hydroboost brake systems\*

### BIG ON STYLE. BIG ON PERFORMANCE.

The LS platform is becoming the go-to engine for Chevy enthusiasts and keeping pace is Billet Specialties Top mount LS Tru Trac. Engineered to clear cross members and steering boxes of muscle cars all the while keeping a slim profile, the LS top mount kit includes all the essentials for a complete engine accessory drive. The Tru Trac's exclusive billet aluminum tensioner keeps constant even tension allowing the 140 amp alternator and Edelbrock water pump to run at full potential without fear of belt slip.

Featuring the best brands in aftermarket performance:



NOW 140 AMP!



### DIMENSIONS - TOP MOUNT LS CHEVY™

To Front Face Of	From Block Face
AC Compressor Cover	7.625"
Alternator Pulley	6.750"
Water Pump Pulley	7.000"
Power Steering Pulley	6.625"
Crankshaft Pulley	6.500"

A: 12.00"  
B: 10.50"  
C: 7.75"

D: 9.125"  
E: 5.00"

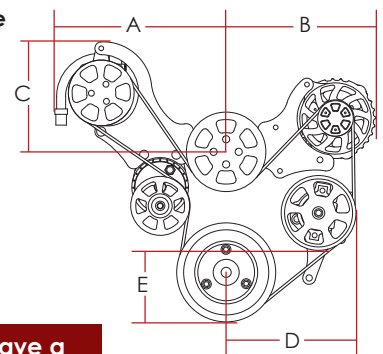

\* Check Clearances Before Ordering \*  
\* Will not work with VVT engines \*

## STANDARD POLISHED KITS

Engineered to work with LS 7 Motors that have a dry sump system & 2 stage oil pumps.

Standard polished Top Mount LS7 Chevrolet® Tru Trac includes the following:

- Polished aluminum pulleys & brackets
- Polished billet tensioner (Tru Trac exclusive)
- Polished 140 amp Powermaster 1-wire alternator
- Natural finish Edelbrock reverse rotation water pump

### Kits with AC Include:

- Polished Sanden SD-7 compressor
- Polished AC clutch cover
- Patented polished billet compressor manifold

### Kits with power steering include:

- Natural finish power steering pump with AN nipples
- Polished power steering pulley installed



With AC  
With Power Steering  
#13460



With AC  
Without Power Steering  
#13490



Without AC  
With Power Steering  
#13465



Without AC  
Without Power Steering  
#13495



# PREMIUM KITS



Premium Top Mount LS7 Chevrolet® Tru Trac includes the following:

- Polished aluminum pulleys & brackets
- Polished billet tensioner (Tru Trac exclusive)
- Polished 140 amp Powermaster 1-wire alternator or polished billet machined case 140 amp alternator
- Natural finish Edelbrock reverse rotation water pump

**Kits with AC include:**

- Polished Sanden SD-7 compressor
- Polished AC clutch cover
- Patented polished billet compressor manifold

**Kits with power steering include:**

- Polished finish power steering pump with AN nipples
- Polished power steering pulley installed



**With AC  
With Power Steering**

With Polished P/S Pump

#13460P

With Polished P/S Pump  
Polished 140 Amp  
Billet Alternator

#13460PA



**With AC  
Without Power Steering**

With Polished 140 Amp  
Billet Alternator

#13490A



**Without AC  
With Power Steering**

With Polished P/S Pump

#13465P

With Polished P/S Pump  
Polished 140 Amp  
Billet Alternator

#13465PA

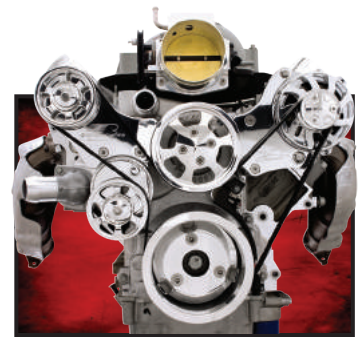

**Without AC  
Without Power Steering**

With Polished 140 Amp  
Billet Alternator

#13495A

# PREMIUM BLACK ANODIZED KITS

With Polished P/S Pump

#BLK13460P

With Polished P/S Pump & Polished  
140 Amp Billet Alternator

#BLK13460PA

*\* Includes all the upgrades from the premium kits above, with black anodized pulleys, brackets, and tensioner\**

# BLACK ANODIZED KITS

Black anodized Top Mount LS7 Chevrolet® Tru Trac includes the following:

- Black anodized aluminum pulleys & brackets
- Black anodized billet tensioner (Tru Trac exclusive)
- Polished 140 amp Powermaster 1-wire alternator
- Natural finish Edelbrock reverse rotation water pump

**Kits with AC include:**

- Polished Sanden SD-7 compressor
- Black anodized AC clutch cover
- Patented black anodized billet compressor manifold

**Kits with power steering include:**

- Natural finish power steering pump with AN nipples
- Black anodized power steering pulley installed



**With AC  
With Power Steering**

#BLK13460



**With AC  
Without Power Steering**

#BLK13490

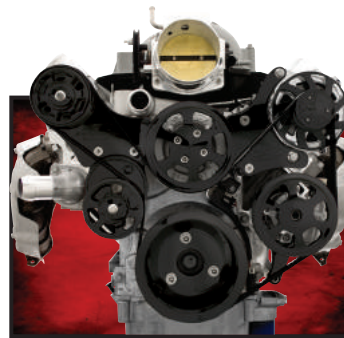

**Without AC  
With Power Steering**

#BLK13465

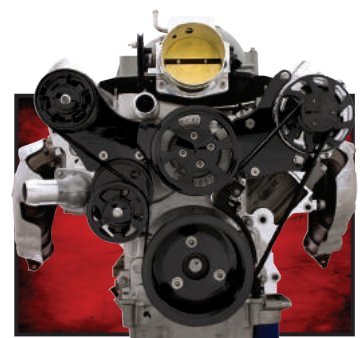

**Without AC  
Without Power Steering**

#BLK13495

# FORD TRU TRAC KITS

**SMALL BLOCK, BIG BLOCK, FE**



"We were truly impressed with the performance and reliability of the Tru Trac on the dyno. This is the only way to go for a front accessory drive system"  
-ROUSH

## **BILLET A/C MANIFOLD**

Kits with AC include our billet aluminum AC manifold, engineered not only to provide an efficient attachment point for the AC hoses, but to look good as well. In fact, so good and efficient we patented it!

## **DURABILITY**

Pulleys that are in contact with the back of the belt are subject to high wear. Billet Specialties hard coat anodizes these areas to eliminate wear altogether. Hard coat anodized aluminum actually provides a harder surface than stock steel pulleys!

## **BILLET TENSIONER**

Our billet aluminum tensioner optimizes belt and accessory life with constant and correct tension; eliminating belt-slip while minimizing parasitic horsepower loss. Every modern car has a tensioner—so should your classic.

## **STAINLESS STANDOFFS**

Our stainless stand-offs provide the most rigid platform in the industry, while maintaining perfect alignment between the accessories. Machined from 303 stainless steel to provide corrosion resistance and double the surface area while adding ease of assembly.



## **FASTENERS**

Tru Trac kits are assembled with 18-8 stainless steel fasteners, offering not only corrosion resistance, but professional appearance and high tensile strength. ARP 12pt. fasteners also match many other Billet Specialties accessories.



## **BILLET TIMING COVER**

True innovation. Our Small Block and Big Block kits feature our exclusive 100% billet aluminum timing cover. This machining marvel supports the components for rock-solid stability while bringing them closer to the block for overall engine clearance.

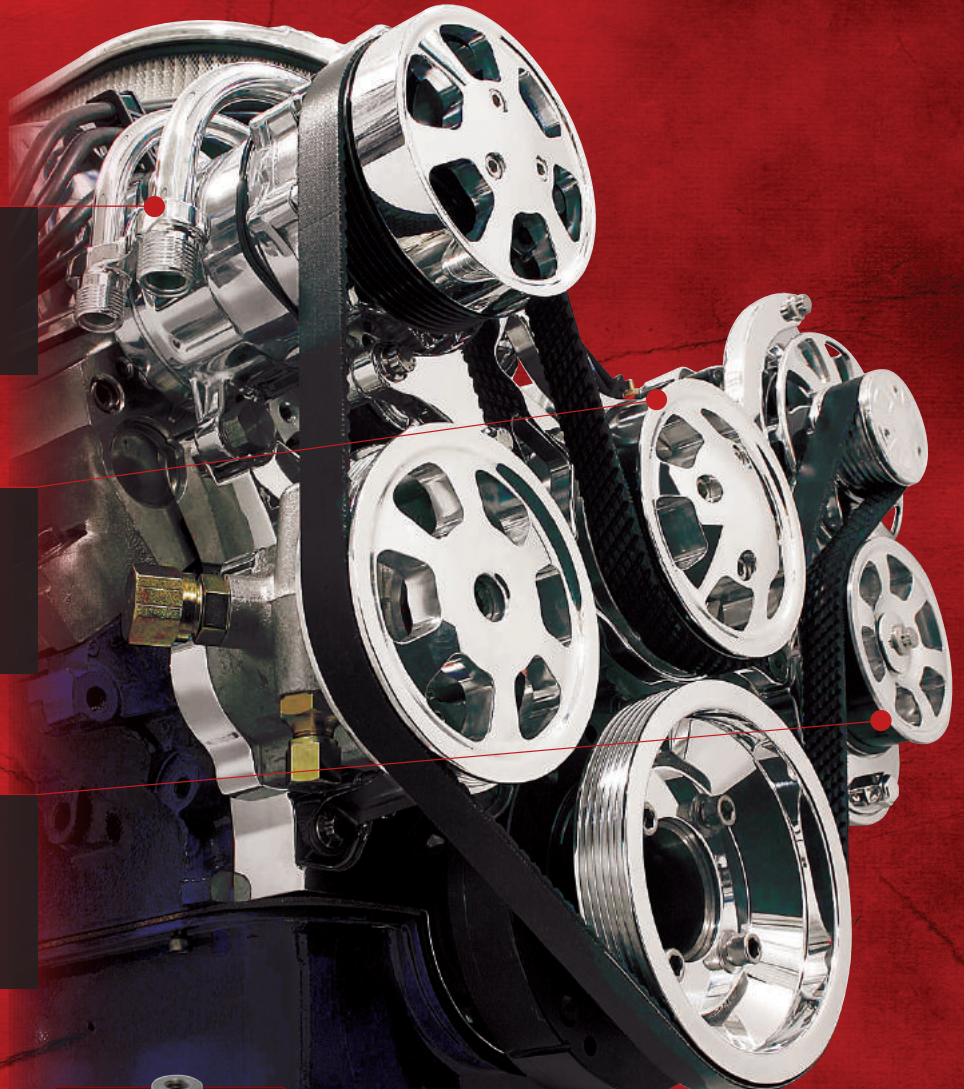
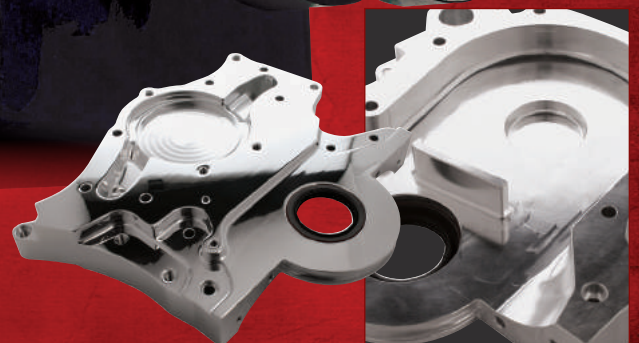

## THE BEST BRANDS INCLUDED!



With over 110 years of racing experience, Ford Racing knows their parts. The Ford Racing water pump included in the small block kits provides superior cooling so your car's operating temperature stays constant.



Edelbrock water pumps provide maximum cooling, utilizing state of the art racing technology. Edelbrock water pumps ensure greater cooling efficiency and reliability for your Big Block 429/460 or FE Tru Trac kit.

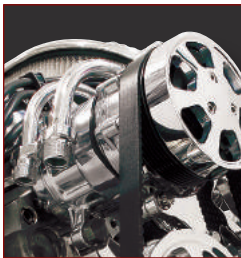

Sanden manufactures and supplies compressors for some of the largest automotive manufacturers in the world. The SD-7 is a high efficiency modern compact compressor ensuring better performance and aesthetics over early 508 compressors while keeping you cool and comfortable.

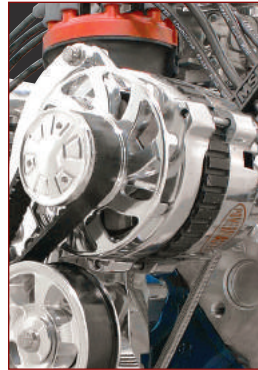

Billet Specialties supplies a new 140 amp Powermaster alternator in every Tru Trac kit. Each Powermaster alternator is 100% new. With a high amp output at idle, internally regulated architecture and internal fan with a gold plated battery post. Each 140 amp alternator is pre-tested and includes a proof of performance tag showing output at idle and at highway speeds. Best of all, Powermaster alternators are made right here in the USA.



Kits with power steering feature modern TC style pumps, used by OEM manufacturers and various applications from NASCAR, Off Road and Road Racing. We supply the pumps with -10AN supply and -6AN pressure nipples installed. Featuring a sealed front bearing and precision internals, each high performance pump is calibrated to 1200 PSI and flows at 3.5 GPM.

## STANDARD POLISHED AND BLACK ANODIZED KITS INCLUDE:



### Natural Finish Water Pump

The traditional look of performance for decades, the natural cast look easily matches your cast intake manifold and power steering pump.

### Polished 140 amp Alternator

Powermaster USA made quality, precision cast and polished case with the best internal components in the industry.

### Natural Finish Power Steering Pump

Matches the natural finish Edelbrock water pump and we pre-install the pulley for ease of installation.

## PREMIUM KITS INCLUDE:

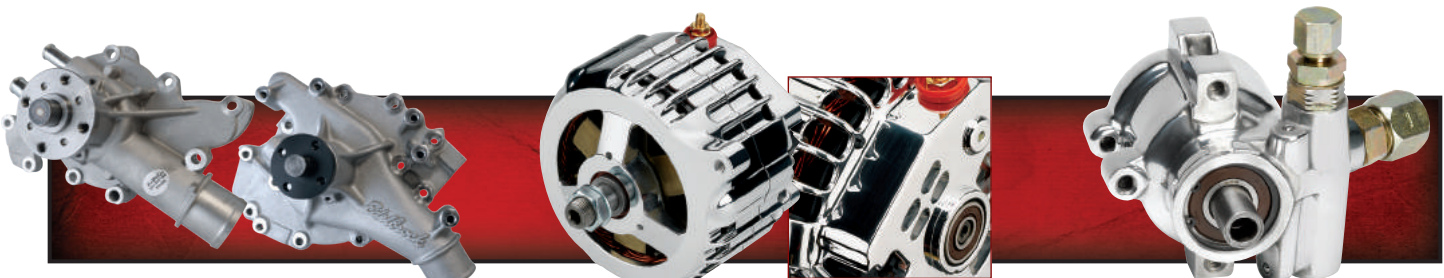

### Natural Finish Water Pump

The traditional look of performance for decades, the natural cast look easily matches your cast intake manifold and power steering pump.

### Optional Billet Aluminum 140 amp Alternator

Truly the crown jewel of the Premium kit. The precision machined 6061-T6 billet case makes this the ultimate alternator.

### Polished Power Steering Pump

Show quality polish and pre-installed pulley for ease of installation.

# FORD SMALL BLOCK

289/302/351W



US PATENT #7,717,080

### All Kits Feature:

- Exclusive billet aluminum tensioner
- 100% billet aluminum timing cover
- Polished ARP 12-point stainless steel fasteners
- Hard-coat anodizing for durability in high-wear areas
- Continental Elite serpentine belt
- Comprehensive instruction manual

\*Tru Trac systems are not designed for use with hydroboost brake systems\*

Includes: Billet Timing Cover

## TRU TRAC: THE ULTIMATE SERPENTINE SYSTEM

Our exclusive design features a 100% precision machined billet aluminum timing cover that supports all components. There is no need to tap into the block. The Tru Trac serpentine system fits 289, 302, and 351W motors.

The Tru Trac for small block Ford fits in the tightest engine bays. Perfect for muscle cars and street rods! The Tru Trac's OE styling gives your motor a clean, professional look.

Featuring the best brands in aftermarket performance:



## DIMENSIONS - SMALL BLOCK FORD

To Front Face Of	From Block Face
AC Compressor Cover	7.750"
Alternator Pulley	6.375"
Water Pump Pulley	7.375"
Power Steering Pulley	6.750"
Crankshaft Pulley	6.500"

A: 9.250"	D: 6.250"
B: 9.125"	E: 7.875"
C: 6.625"	

\* Check Clearances Before Ordering \*

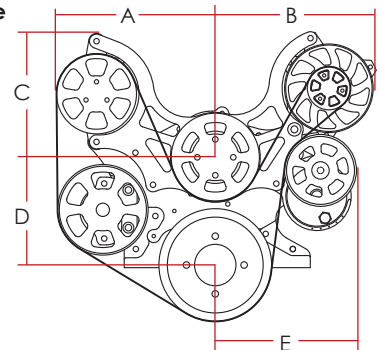

## STANDARD POLISHED KITS

Standard polished 289/302/351W Ford Tru Trac includes the following:

- Polished aluminum pulleys & brackets
- Polished billet tensioner (Tru Trac exclusive)
- Polished 140 amp Powermaster 1-wire alternator
- Natural finish Ford Racing reverse rotation water pump

### Kits with AC Include:

- Polished Sanden SD-7 compressor
- Polished AC clutch cover
- Patented polished billet compressor manifold

### Kits with power steering include:

- Natural finish power steering pump with AN nipples
- Polished power steering pulley installed

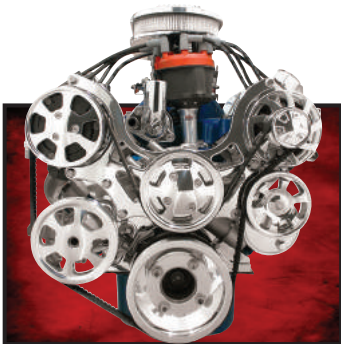

With AC  
With Power Steering  
#13600

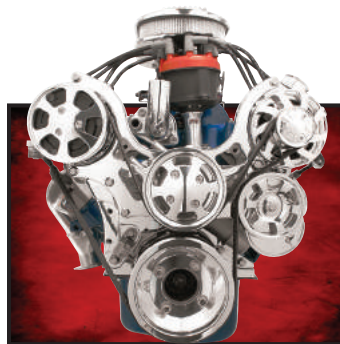

With AC  
Without Power Steering  
#13620



Without AC  
With Power Steering  
#13605



Without AC  
Without Power Steering  
#13625

Front Sump Oil Pan Dipstick - #40150

\* For use with front sump oil pans only - see page 37 for details, \*

# PREMIUM KITS



Premium 289/302/351W Ford Tru Trac includes the following:

- Polished aluminum pulleys & brackets
- Polished billet tensioner (Tru Trac exclusive)
- Polished 140 amp Powermaster 1-wire alternator or polished billet machined case 140 amp alternator
- Natural finish Ford Racing reverse rotation water pump

**Kits with AC include:**

- Polished Sanden SD-7 compressor
- Polished AC clutch cover
- Patented polished billet compressor manifold

**Kits with power steering include:**

- Polished finish power steering pump with AN nipples
- Polished power steering pulley installed

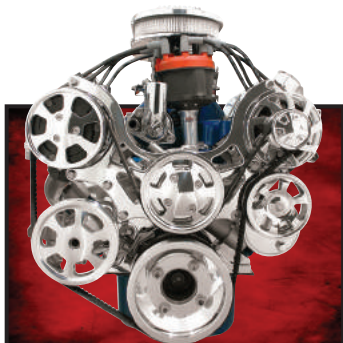

**With AC  
With Power Steering**

With Polished P/S Pump

**#13600P**

With Polished P/S Pump  
Polished 140 Amp  
Billet Alternator  
**#13600PA**

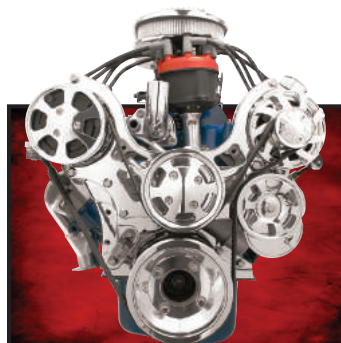

**With AC  
Without Power Steering**

With Polished 140 Amp  
Billet Alternator

**#13620A**



**Without AC  
With Power Steering**

With Polished P/S Pump

**#13605P**

With Polished P/S Pump  
Polished 140 Amp  
Billet Alternator  
**#13605PA**



**Without AC  
Without Power Steering**

With Polished 140 Amp  
Billet Alternator

**#13625A**

# PREMIUM BLACK ANODIZED KITS

With Polished P/S Pump

**#BLK13600P**

With Polished P/S Pump & Polished  
140 Amp Billet Alternator

**#BLK13600PA**

*\* Includes all the upgrades from the premium kits above, with black anodized pulleys, brackets, and tensioner\**

# BLACK ANODIZED KITS

Black anodized 289/302/351W Ford Tru Trac includes the following:

- Black anodized aluminum pulleys & brackets
- Black anodized billet tensioner (Tru Trac exclusive)
- Polished 140 amp Powermaster 1-wire alternator
- Natural finish Ford Racing reverse rotation water pump
- Black anodized timing cover

**Kits with AC include:**

- Polished Sanden SD-7 compressor
- Black anodized AC clutch cover
- Patented black anodized billet compressor manifold

**Kits with power steering include:**

- Natural finish power steering pump with AN nipples
- Black anodized power steering pulley



**With AC  
With Power Steering**  
**#BLK13600**



**With AC  
Without Power Steering**  
**#BLK13620**



**Without AC  
With Power Steering**  
**#BLK13605**

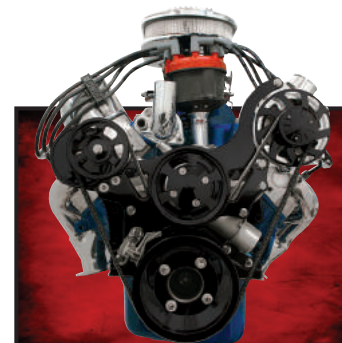

**Without AC  
Without Power Steering**  
**#BLK13625**

# FORD BIG BLOCK

429/460



Patent-Pending

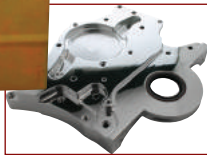

Includes: Billet Timing Cover

### All Kits Feature:

- Exclusive billet aluminum tensioner
- 100% billet aluminum timing cover
- Polished ARP 12-point stainless steel fasteners
- Hard-coat anodizing for durability in high-wear areas
- Continental Elite serpentine belt
- Comprehensive instruction manual

\*Tru Trac systems are not designed for use with hydroboost brake systems\*

## EVERYTHING YOU NEED IS RIGHT HERE

Superior design, performance and style. Based on the successful and proven small block design, Billet Specialties big block Ford Tru Trac serpentine system answers the call for performance and style in one compact package. True innovation is the key here, from our patented billet aluminum timing cover and our exclusive billet tensioner specifically engineered for the system right down to the smallest details such as stainless hardware.

Featuring the best brands in aftermarket performance:



NOW 140 AMP!



## DIMENSIONS - BIG BLOCK FORD

To Front Face Of	From Block Face
AC Compressor Cover	8.125"
Alternator Pulley	7.125"
Water Pump Pulley	8.250"
Power Steering Pulley	7.250"
Crankshaft Pulley	7.000"

A: 10.25"      D: 7.375"  
 B: 9.75"        E: 11.00"  
 C: 5.75"

\* Check Clearances Before Ordering \*

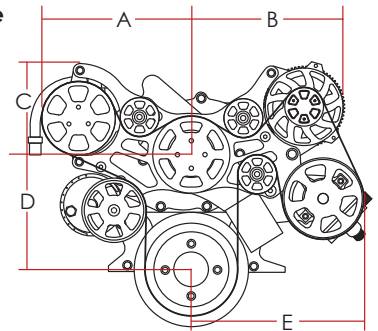

### IMPORTANT - THIS KIT REQUIRES:

- Use of an electric fuel pump
- Oil pan with dipstick provision

## STANDARD POLISHED KITS

Standard polished 429/460 Ford Tru Trac includes the following:

- Polished aluminum pulleys & brackets
- Polished billet tensioner (Tru Trac exclusive)
- Polished 140 amp Powermaster 1-wire alternator
- Natural finish Edelbrock standard rotation water pump

### Kits with AC Include:

- Polished Sanden SD-7 compressor
- Polished AC clutch cover
- Patented polished billet compressor manifold

### Kits with power steering include:

- Natural finish power steering pump with AN nipples
- Polished power steering pulley installed



With AC  
 With Power Steering  
 #14600

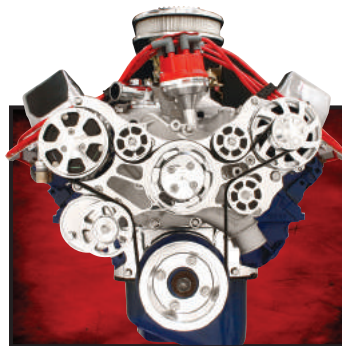

With AC  
 Without Power Steering  
 #14620

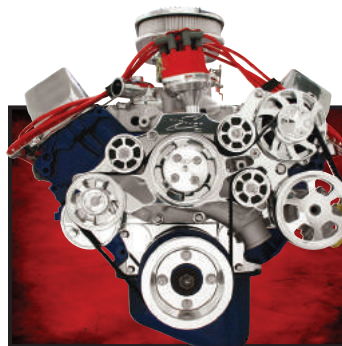

Without AC  
 With Power Steering  
 #14605

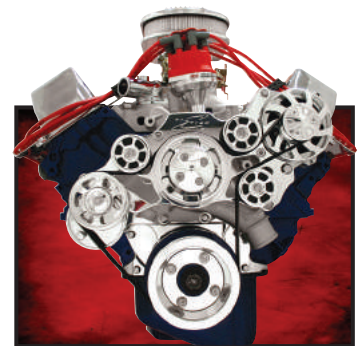

Without AC  
 Without Power Steering  
 #14625



"Our cars are built to drive coast to coast. Take it from a long-time Ford guy...  
 Billet Specialties Tru Trac Serpentine System for Ford is truly a work of art that PERFORMS!"

- ROY BRIZIO

# PREMIUM KITS



Premium 429/460 Ford Tru Trac includes the following:

- Polished aluminum pulleys & brackets
- Polished billet tensioner (Tru Trac exclusive)
- Polished 140 amp Powermaster 1-wire alternator or polished billet machined case 140 amp alternator
- Natural finish Edelbrock standard rotation water pump

**Kits with AC include:**

- Polished Sanden SD-7 compressor
- Polished AC clutch cover
- Patented polished billet compressor manifold

**Kits with power steering include:**

- Polished finish power steering pump with AN nipples
- Polished power steering pulley installed



**With AC  
With Power Steering**

With Polished P/S Pump

**#14600P**

With Polished P/S Pump  
Polished 140 Amp  
Billet Alternator  
**#14600PA**



**With AC  
Without Power Steering**

With Polished 140 Amp  
Billet Alternator

**#14620A**



**Without AC  
With Power Steering**

With Polished P/S Pump

**#14605P**

With Polished P/S Pump  
Polished 140 Amp  
Billet Alternator  
**#14605PA**

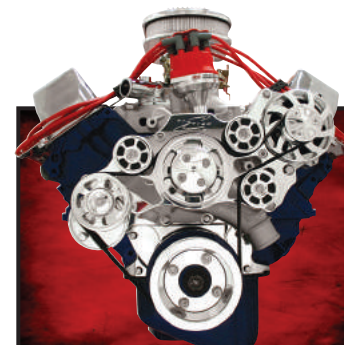

**Without AC  
Without Power Steering**

With Polished 140 Amp  
Billet Alternator

**#14625A**

# PREMIUM BLACK ANODIZED KITS

With Polished P/S Pump

**#BLK14600P**

With Polished P/S Pump & Polished  
140 Amp Billet Alternator

**#BLK14600PA**

*\* Includes all the upgrades from the premium kits above, with black anodized pulleys, brackets, and tensioner\**

# BLACK ANODIZED KITS

Black anodized 429/460 Ford Tru Trac includes the following:

- Black anodized aluminum pulleys & brackets
- Black anodized billet tensioner (Tru Trac exclusive)
- Polished 140 amp Powermaster 1-wire alternator
- Natural finish Edelbrock standard rotation water pump
- Black anodized timing cover

**Kits with AC include:**

- Polished Sanden SD-7 compressor
- Black anodized AC clutch cover
- Patented black anodized billet compressor manifold

**Kits with power steering include:**

- Natural finish power steering pump with AN nipples
- Black anodized power steering pulley installed

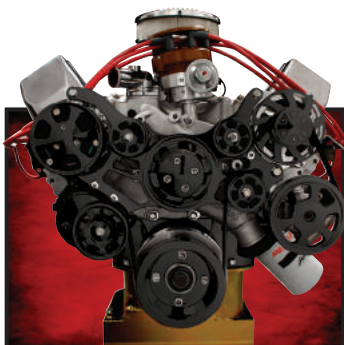

**With AC  
With Power Steering  
#BLK14600**



**With AC  
Without Power Steering  
#BLK14620**



**Without AC  
With Power Steering  
#BLK14605**

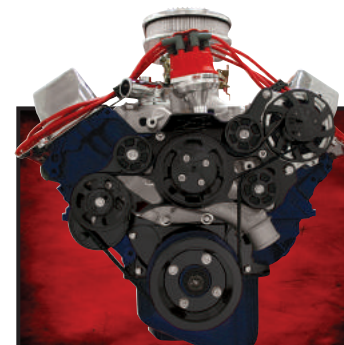

**Without AC  
Without Power Steering  
#BLK14625**

# FORD FE

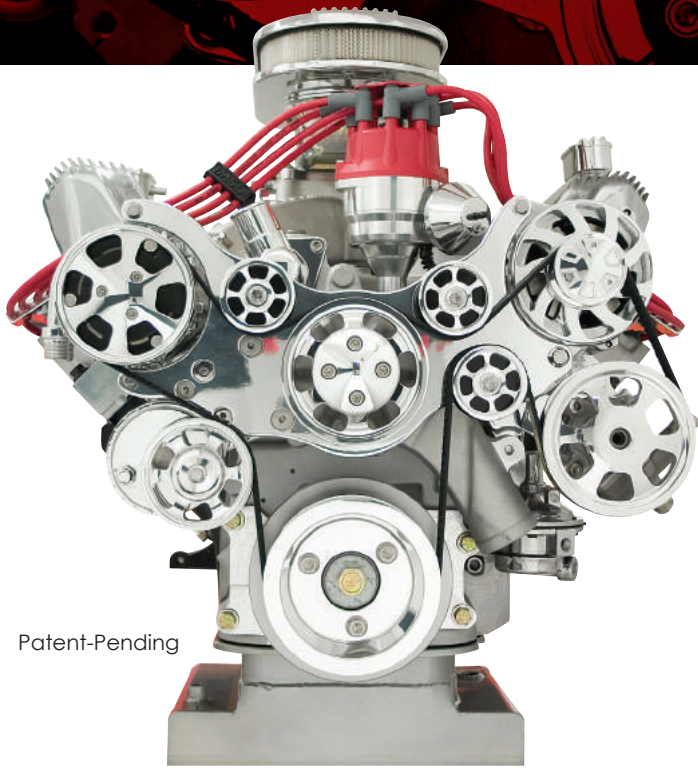

Patent-Pending

#### All Kits Feature:

- Exclusive billet aluminum tensioner
- Polished ARP 12-point stainless steel fasteners
- Hard-coat anodizing for durability in high-wear areas
- Continental Elite serpentine belt
- Comprehensive instruction manual

\*Tru Trac systems are not designed for use with hydroboost brake systems\*

## A LEGEND GETS A NEW LOOK

From LeMans to Daytona, the Ford FE has become a legend in the automotive world. Combining Billet Specialties' innovative design, precision machined aluminum brackets and pulleys, along with top components from Edelbrock, Powermaster, and Goodyear, the Tru Trac for Ford FE is sure to become a legend all its own.

Featuring the best brands in aftermarket performance:



NOW 140 AMP!



## DIMENSIONS - FE FORD

To Front Face Of	From Block Face
AC Compressor Cover	7.875"
Alternator Pulley	7.500"
Water Pump Pulley	8.500"
Power Steering Pulley	7.250"
Crankshaft Pulley	7.125"

A: 11.00"	D: 7.00"
B: 10.50"	E: 11.50"
C: 6.00"	

\* Check Clearances Before Ordering \*

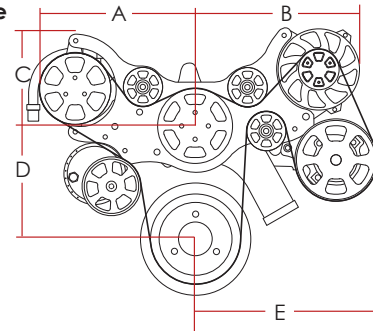

### IMPORTANT - THIS KIT REQUIRES:

- Early FE motors require the use of a crank damper (not included)

## STANDARD POLISHED KITS

Standard polished FE Ford Tru Trac includes the following:

- Polished aluminum pulleys & brackets
- Polished billet tensioner (Tru Trac exclusive)
- Polished 140 amp Powermaster 1-wire alternator
- Natural finish Edelbrock standard rotation water pump

#### Kits with AC Include:

- Polished Sanden SD-7 compressor
- Polished AC clutch cover
- Patented polished billet compressor manifold

#### Kits with power steering include:

- Natural finish power steering pump with AN nipples
- Polished power steering pulley installed



With AC  
With Power Steering  
#14700

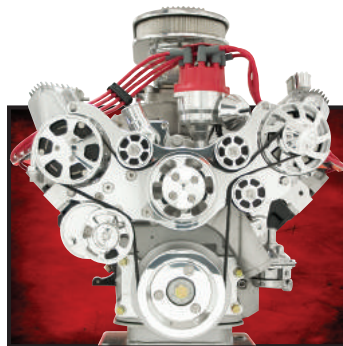

With AC  
Without Power Steering  
#14720



Without AC  
With Power Steering  
#14705

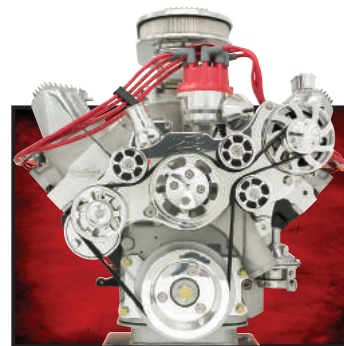

Without AC  
Without Power Steering  
#14725



# PREMIUM KITS



Premium FE Ford Tru Trac includes the following:

- Polished aluminum pulleys & brackets
- Polished billet tensioner (Tru Trac exclusive)
- Polished 140 amp Powermaster 1-wire alternator or polished billet machined case 140 amp alternator
- Natural finish Edelbrock standard rotation water pump

**Kits with AC include:**

- Polished Sanden SD-7 compressor
- Polished AC clutch cover
- Patented polished billet compressor manifold

**Kits with power steering include:**

- Polished finish power steering pump with AN nipples
- Polished power steering pulley installed



**With AC  
With Power Steering**

With Polished P/S Pump

#14700P

With Polished P/S Pump  
Polished 140 Amp  
Billet Alternator  
#14700PA

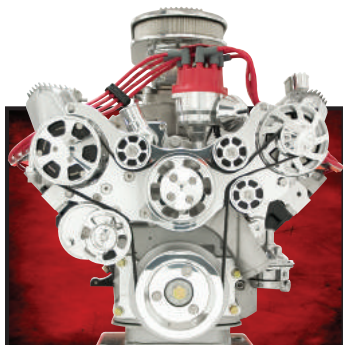

**With AC  
Without Power Steering**

With Polished 140 Amp  
Billet Alternator

#14720A



**Without AC  
With Power Steering**

With Polished P/S Pump

#14705P

With Polished P/S Pump  
Polished 140 Amp  
Billet Alternator  
#14705PA

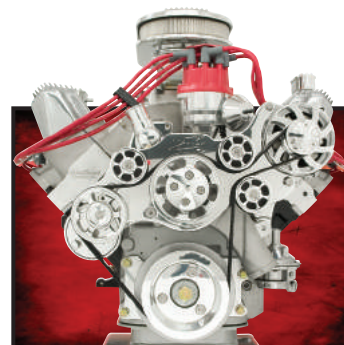

**Without AC  
Without Power Steering**

With Polished 140 Amp  
Billet Alternator

#14725A

# PREMIUM BLACK ANODIZED KITS

With Polished P/S Pump

#BLK14700P

With Polished P/S Pump & Polished  
140 Amp Billet Alternator

#BLK14700PA

*\* Includes all the upgrades from the premium kits above, with black anodized pulleys, brackets, and tensioner\**

# BLACK ANODIZED KITS

Black anodized FE Ford Tru Trac includes the following:

- Black anodized aluminum pulleys & brackets
- Black anodized billet tensioner (Tru Trac exclusive)
- Polished 140 amp Powermaster 1-wire alternator
- Natural finish Edelbrock standard rotation water pump

**Kits with AC include:**

- Polished Sanden SD-7 compressor
- Black anodized AC clutch cover
- Patented black anodized billet compressor manifold

**Kits with power steering include:**

- Natural finish power steering pump with AN nipples
- Black anodized power steering pulley installed



**With AC  
With Power Steering**  
#BLK14700

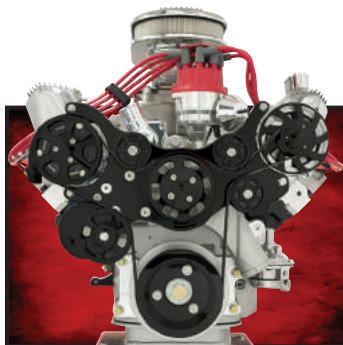

**With AC  
Without Power Steering**  
#BLK14720

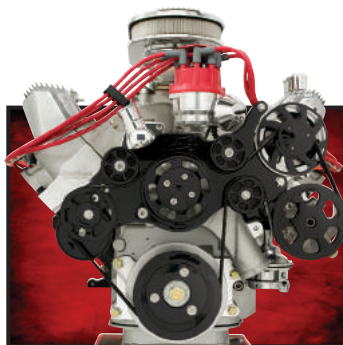

**Without AC  
With Power Steering**  
#BLK14705

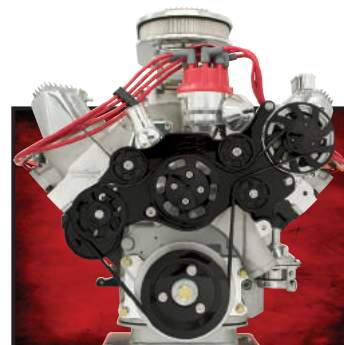

**Without AC  
Without Power Steering**  
#BLK14725

# CHRYSLER TRU TRAC KITS

SMALL BLOCK, BIG BLOCK, HEMI



"The Tru Trac's reliability, style and performance definitely makes a statement under the hood"

-BOBBY ALLOWAY

## BILLET A/C MANIFOLD

Kits with AC include our billet aluminum AC manifold, engineered not only to provide an efficient attachment point for the AC hoses, but to look good as well. In fact, so good and efficient we patented it!

## BILLET TENSIONER

Our billet aluminum tensioner optimizes belt and accessory life with constant and correct tension; eliminating belt-slip while minimizing parasitic horsepower loss. Every modern car has a tensioner—so should your classic.

## DURABILITY

Pulleys that are in contact with the back of the belt are subject to high wear. Billet Specialties hard coat anodizes these areas to eliminate wear altogether. Hard coat anodized aluminum actually provides a harder surface than stock steel pulleys!

## STAINLESS STANDOFFS

Our stainless stand-offs provide the most rigid platform in the industry, while maintaining perfect alignment between the accessories. Machined from 303 stainless steel to provide corrosion resistance and double the surface area while adding ease of assembly.



## FASTENERS

Tru Trac kits are assembled with 18-8 stainless steel fasteners, offering not only corrosion resistance, but professional appearance and high tensile strength. ARP 12pt. fasteners also match many other Billet Specialties accessories.

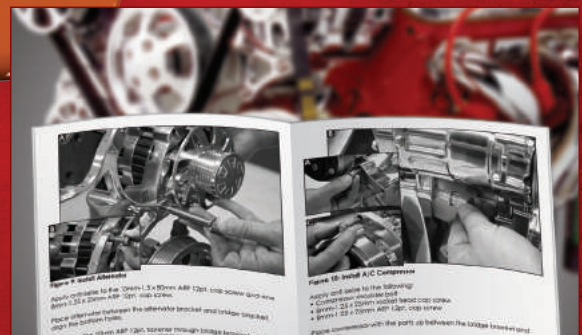

## EASE OF INSTALLATION

With our comprehensive instruction booklet and pre-installed alternator and power steering pulleys, installing a Tru Trac is easy.



## THE BEST BRANDS INCLUDED!



Big block and HEMI Tru Tracs include a new natural cast finish aluminum water pump housing and Mopar Performance water pump. The eight-blade impeller will keep your engine temp in check on those hot summer days.



Edelbrock water pumps provide maximum cooling, utilizing state of the art racing technology. Edelbrock water pumps ensure greater cooling efficiency and reliability for your small block Chrysler Tru Trac kit.

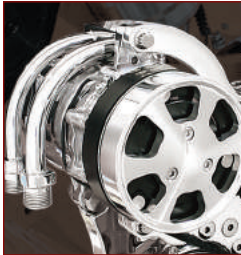

Sanden manufactures and supplies compressors for some of the largest automotive manufacturers in the world. The SD-7 is a high efficiency modern compact compressor ensuring better performance and aesthetics over early 508 compressors while keeping you cool and comfortable.



Billet Specialties supplies a new 140 amp Powermaster alternator in every Tru Trac kit. Each Powermaster alternator is 100% new. With a high amp output at idle, internally regulated architecture and internal fan with a gold plated battery post. Each 140 amp alternator is pre-tested and includes a proof of performance tag showing output at idle and at highway speeds. Best of all, Powermaster alternators are made right here in the USA.

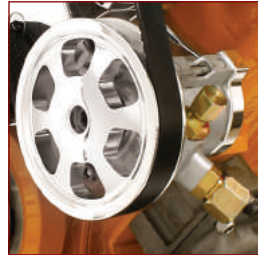

Kits with power steering feature modern TC style pumps, used by OEM manufacturers and various applications from NASCAR, Off Road and Road Racing. We supply the pumps with -10AN supply and -6AN pressure nipples installed. Featuring a sealed front bearing and precision internals, each high performance pump is calibrated to 1200 PSI and flows at 3.5 GPM.

## STANDARD POLISHED AND BLACK ANODIZED KITS INCLUDE:



### Natural Finish Water Pump

The traditional look of performance for decades, the natural cast look easily matches your cast intake manifold and power steering pump.



### Polished 140 amp Alternator

Powermaster USA made quality, precision cast and polished case with the best internal components in the industry.

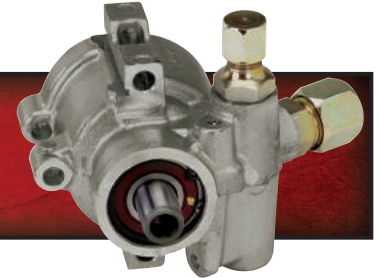

### Natural Finish Power Steering

Matches the natural finish Edelbrock water pump and we pre-install the pulley for ease of installation.

## PREMIUM KITS INCLUDE:



### Natural Finish Water Pump

The traditional look of performance for decades, the natural cast look easily matches your cast intake manifold and power steering pump.



### Optional Billet Aluminum 140 amp Alternator

Truly the crown jewel of the Premium kit. The precision machined 6061-T6 billet case makes this the ultimate alternator.

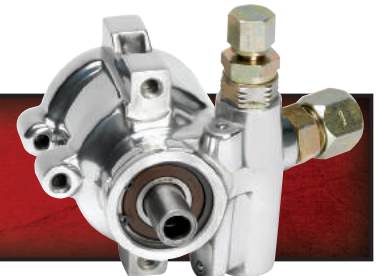

### Polished Power Steering Pump

Show quality polish and pre-installed pulley for ease of installation.

# CHRYSLER SMALL BLOCK

318/340/360



Patent-Pending

#### All Kits Feature:

- Exclusive billet aluminum tensioner
- Polished ARP 12-point stainless steel fasteners
- Hard-coat anodizing for durability in high-wear areas
- Continental Elite serpentine belt
- Comprehensive instruction manual

\*Tru Trac systems are not designed for use with hydroboost brake systems\*

### TIME TO SHOW OFF

The small block LA series motor that has proven its performance and reliability over the years as Chrysler's best selling engine is about to get the ultimate upgrade. Using the same successful formula as the rest of the Tru Trac family, the small block Chrysler Tru Trac stands alone as the most complete and efficient accessory drive system on the market.

Featuring the best brands in aftermarket performance:



NOW 140 AMP!



### DIMENSIONS - SMALL BLOCK CHRYSLER

To Front Face Of	From Block Face
AC Compressor Cover	8.125"
Alternator Pulley	7.625"
Water Pump Pulley	9.125"
Power Steering Pulley	7.375"
Crankshaft Pulley	7.375"

A: 9.75"	D: 6.875"
B: 10.25"	E: 10.00"
C: 7.25"	

\* Check Clearances Before Ordering \*

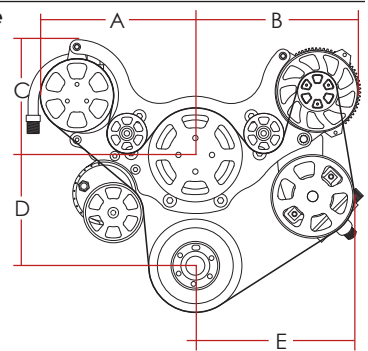

### IMPORTANT - THIS KIT REQUIRES:

- Use of an electric fuel pump

## STANDARD POLISHED KITS

Standard polished 318/340/360 Chrysler Tru Trac includes the following:

- Polished aluminum pulleys & brackets
- Polished billet tensioner (Tru Trac exclusive)
- Polished 140 amp Powermaster 1-wire alternator
- Natural finish Edelbrock standard rotation water pump

#### Kits with AC Include:

- Polished Sanden SD-7 compressor
- Polished AC clutch cover
- Patented polished billet compressor manifold

#### Kits with power steering include:

- Natural finish power steering pump with AN nipples
- Polished power steering pulley installed



With AC  
With Power Steering  
#13800



With AC  
Without Power Steering  
#13820



Without AC  
With Power Steering  
#13805



Without AC  
Without Power Steering  
#13825

# PREMIUM KITS



Premium 318/340/360 Chrysler Tru Trac includes the following:

- Polished aluminum pulleys & brackets
- Polished billet tensioner (Tru Trac exclusive)
- Polished 140 amp Powermaster 1-wire alternator or polished billet machined case 140 amp alternator
- Natural finish Edelbrock standard rotation water pump

**Kits with AC include:**

- Polished Sanden SD-7 compressor
- Polished AC clutch cover
- Patented polished billet compressor manifold

**Kits with power steering include:**

- Polished finish power steering pump with AN nipples
- Polished power steering pulley installed



**With AC  
With Power Steering**

With Polished P/S Pump

#13800P

With Polished P/S Pump  
Polished 140 Amp  
Billet Alternator  
#13800PA



**With AC  
Without Power Steering**

With Polished 140 Amp  
Billet Alternator

#13820A



**Without AC  
With Power Steering**

With Polished P/S Pump

#13805P

With Polished P/S Pump  
Polished 140 Amp  
Billet Alternator  
#13805PA



**Without AC  
Without Power Steering**

With Polished 140 Amp  
Billet Alternator

#13825A

# PREMIUM BLACK ANODIZED KITS

With Polished P/S Pump

#BLK13800P

With Polished P/S Pump & Polished  
140 Amp Billet Alternator

#BLK13800PA

*\* Includes all the upgrades from the premium kits above, with black anodized pulleys, brackets, and tensioner\**

# BLACK ANODIZED KITS

Black anodized 318/340/360 Chrysler Tru Trac includes the following:

- Black anodized aluminum pulleys & brackets
- Black anodized billet tensioner (Tru Trac exclusive)
- Polished 140 amp Powermaster 1-wire alternator
- Natural finish Edelbrock standard rotation water pump

**Kits with AC include:**

- Polished Sanden SD-7 compressor
- Black anodized AC clutch cover
- Patented black anodized billet compressor manifold

**Kits with power steering include:**

- Natural finish power steering pump with AN nipples
- Black anodized power steering pulley installed



**With AC  
With Power Steering**  
#BLK13800



**With AC  
Without Power Steering**  
#BLK13820

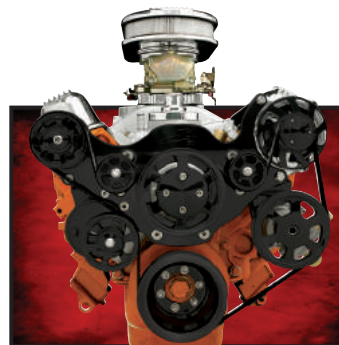

**Without AC  
With Power Steering**  
#BLK13805



**Without AC  
Without Power Steering**  
#BLK13825

# CHRYSLER HEMI/BIG BLOCK



Patent-Pending

#### All Kits Feature:

- Exclusive billet aluminum tensioner
- Polished ARP 12-point stainless steel fasteners
- Hard-coat anodizing for durability in high-wear areas
- Continental Elite serpentine belt
- Comprehensive instruction manual

\*Tru Trac systems are not designed for use with hydroboost brake systems\*

## 383/440 B/RB, '66 & UP 426 HEMI 426/472/528 HEMI CRATE TRU TRAC SYSTEM

Attitude, Style & Performance for the legendary Hemi motor is here right now. Billet Specialties' Tru Trac is the answer for the ultimate accessory drive system for your HEMI. Everything you need is right here: pulleys, brackets, A/C compressor, alternator, power steering pump, water pump & housing. All in one, ready to bolt on kit. Billet Specialties' innovative mounting system allows the use of any type of cylinder head.

Featuring the best brands in aftermarket performance:



### DIMENSIONS - HEMI/BIG BLOCK CHRYSLER

To Front Face Of	From Block Face
AC Compressor Cover	7.375"
Alternator Pulley	6.250"
Water Pump Pulley	8.125"
Power Steering Pulley	6.000"
Crankshaft Pulley	5.875"

A: 11.75"	D: 6.875"
B: 12.00"	E: 11.875"
C: 6.625"	

\* Check Clearances Before Ordering \*

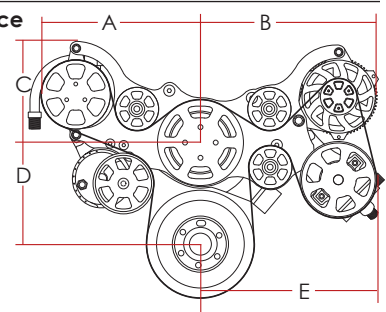

#### IMPORTANT - THIS KIT REQUIRES:

- Use of a thin style damper

## STANDARD POLISHED KITS

Standard polished HEMI/Big Block Chrysler Tru Trac includes the following:

- Polished aluminum pulleys & brackets
- Polished billet tensioner (Tru Trac exclusive)
- Polished 140 amp Powermaster 1-wire alternator
- Natural finish Mopar water pump

#### Kits with AC Include:

- Polished Sanden SD-7 compressor
- Polished AC clutch cover
- Patented polished billet compressor manifold

#### Kits with power steering include:

- Natural finish power steering pump with AN nipples
- Polished power steering pulley installed



With AC  
With Power Steering  
#14800



With AC  
Without Power Steering  
#14820



Without AC  
With Power Steering  
#14805



Without AC  
Without Power Steering  
#14825

## PREMIUM KITS



Premium HEMI/Big Block Chrysler Tru Trac includes the following:

- Polished aluminum pulleys & brackets
- Polished billet tensioner (Tru Trac exclusive)
- Polished 140 amp Powermaster 1-wire alternator or polished billet machined case 140 amp alternator
- Natural finish Mopar water pump

**Kits with AC include:**

- Polished Sanden SD-7 compressor
- Polished AC clutch cover
- Patented polished billet compressor manifold

**Kits with power steering include:**

- Polished finish power steering pump with AN nipples
- Polished power steering pulley installed



**With AC  
With Power Steering**

With Polished P/S Pump

**#14800P**

With Polished P/S Pump  
Polished 140 Amp  
Billet Alternator

**#14800PA**



**With AC  
Without Power Steering**

With Polished 140 Amp  
Billet Alternator

**#14820A**



**Without AC  
With Power Steering**

With Polished P/S Pump

**#14805P**

With Polished P/S Pump  
Polished 140 Amp  
Billet Alternator

**#14805PA**



**Without AC  
Without Power Steering**

With Polished 140 Amp  
Billet Alternator

**#14825A**

## PREMIUM BLACK ANODIZED KITS

With Polished P/S Pump

**#BLK14800P**

With Polished P/S Pump & Polished  
140 Amp Billet Alternator

**#BLK14800PA**

*\* Includes all the upgrades from the premium kits above, with black anodized pulleys, brackets, and tensioner\**

## BLACK ANODIZED KITS

Black anodized HEMI/Big Block Chrysler Tru Trac includes the following:

- Black anodized aluminum pulleys & brackets
- Black anodized billet tensioner (Tru Trac exclusive)
- Polished 140 amp Powermaster 1-wire alternator
- Natural finish Mopar water pump

**Kits with AC include:**

- Polished Sanden SD-7 compressor
- Black anodized AC clutch cover
- Patented black anodized billet compressor manifold

**Kits with power steering include:**

- Natural finish power steering pump with AN nipples
- Black anodized power steering pulley installed



**With AC  
With Power Steering**  
**#BLK14800**



**With AC  
Without Power Steering**  
**#BLK14820**



**Without AC  
With Power Steering**  
**#BLK14805**



**Without AC  
Without Power Steering**  
**#BLK14825**

# PONTIAC TRU TRAC KITS

326/455

## BILLET A/C MANIFOLD

Kits with AC include our billet aluminum AC manifold, engineered not only to provide an efficient attachment point for the AC hoses, but to look good as well. In fact, so good and efficient we patented it!

## BILLET TENSIONER

Our billet aluminum tensioner optimizes belt and accessory life with constant and correct tension; eliminating belt-slip while minimizing parasitic horsepower loss. Every modern car has a tensioner—so should your classic.

## DURABILITY

Pulleys that are in contact with the back of the belt are subject to high wear. Billet Specialties hard coat anodizes these areas to eliminate wear altogether. Hard coat anodized aluminum actually provides a harder surface than stock steel pulleys!

## STAINLESS STANDOFFS

Our stainless stand-offs provide the most rigid platform in the industry, while maintaining perfect alignment between the accessories. Machined from 303 stainless steel to provide corrosion resistance and double the surface area while adding ease of assembly.



## FASTENERS

Tru Trac kits are assembled with 18-8 stainless steel fasteners, offering not only corrosion resistance, but professional appearance and high tensile strength. ARP 12pt. fasteners also match many other Billet Specialties accessories.

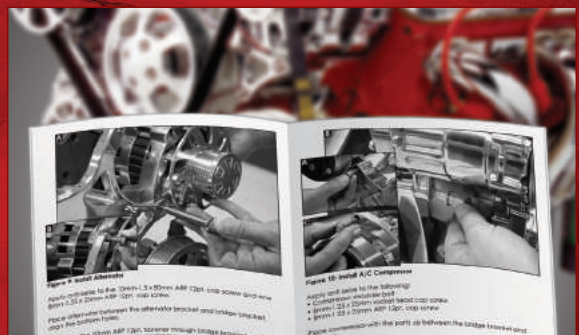

## EASE OF INSTALLATION

With our comprehensive instruction booklet and pre-installed alternator and power steering pulleys, installing a Tru Trac is easy.



## THE BEST BRANDS INCLUDED!



Designed and cast in the USA, Edelbrock water pumps provide maximum flow, maximum pressure and equal distribution to both sides of the block within 1%. Featuring Edelbrock's industry leading precision powered metal impeller with modern vane design that is larger than other high-performance pumps along with the precision machined computer designed A-356 Cast pump housing.



Billet Specialties supplies a new 140 amp Powermaster alternator in every Tru Trac kit. Each Powermaster alternator is 100% new. With a high amp output at idle, internally regulated architecture and internal fan with a gold plated battery post. Each 140 amp alternator is pre-tested and includes a proof of performance tag showing output at idle and at highway speeds. Best of all, Powermaster alternators are made right here in the USA.

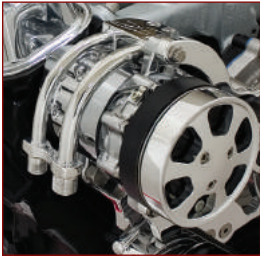

Sanden manufactures and supplies compressors for some of the largest automotive manufacturers in the world. The SD-7 is a high efficiency modern compact compressor ensuring better performance and aesthetics over early 508 compressors while keeping you cool and comfortable.



Kits with power steering feature modern TC style pumps, used by OEM manufacturers and various applications from NASCAR, Off Road and Road Racing. We supply the pumps with -10AN supply and -6AN pressure nipples installed. Featuring a sealed front bearing and precision internals, each high performance pump is calibrated to 1200 PSI and flows at 3.5 GPM.

## STANDARD POLISHED AND BLACK ANODIZED KITS INCLUDE:

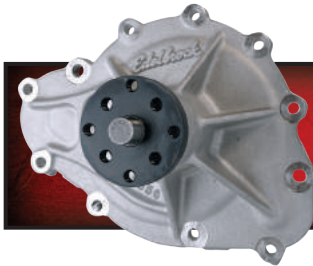

### Natural Finish Water Pump

The traditional look of performance for decades, the natural cast look easily matches your cast intake manifold and power steering pump.



### Polished 140 amp Alternator

Powermaster USA made quality, precision cast and polished case with the best internal components in the industry.

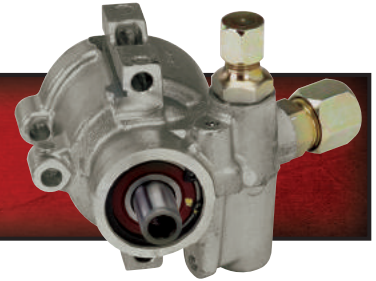

### Natural Finish Power Steering Pump

Matches the natural finish Edelbrock water pump and we pre-install the pulley for ease of installation.

## PREMIUM KITS INCLUDE:

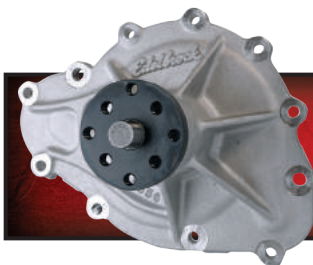

### Natural Finish Water Pump

The traditional look of performance for decades, the natural cast look easily matches your cast intake manifold and power steering pump.



### Optional Billet Aluminum 140 amp Alternator

Truly the crown jewel of the Premium kit. The precision machined 6061-T6 billet case makes this the ultimate alternator.

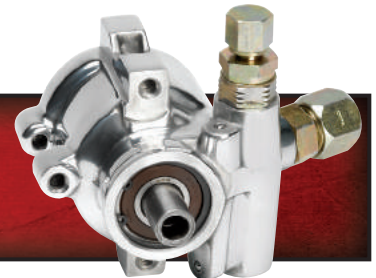

### Polished Power Steering Pump

Show quality polish and pre-installed pulley for ease of installation.

# PONTIAC 326-455



Patent-Pending

### All Kits Feature:

- Exclusive billet aluminum tensioner
- Polished ARP 12-point stainless steel fasteners
- Hard-coat anodizing for durability in high-wear areas
- Continental Elite serpentine belt
- Comprehensive instruction manual

\*Tru Trac systems are not designed for use with hydroboost brake systems\*

### PONTIAC'S TURN IN THE SPOTLIGHT

It's Game On for Pontiac power plants as the void in performance accessory drives has been filled. Billet Specialties has answered your requests with the Tru Trac for the 326/455 Pontiac. Using the proven Tru Trac formula of quality, ease of assembly, the best name brand components & superior engineering the Tru Trac for Pontiac is sure to be a hit from Woodward to Van Nuys.

Featuring the best brands in aftermarket performance:



### DIMENSIONS - 326-455 PONTIAC

To Front Face Of	From Block Face
AC Compressor Cover	7.250"
Alternator Pulley	6.875"
Water Pump Pulley	8.125"
Power Steering Pulley	6.500"
Crankshaft Pulley	6.625"

A: 10.25"	D: 8.00"
B: 10.50"	E: 11.125"
C: 5.50"	

\* Check Clearances Before Ordering \*

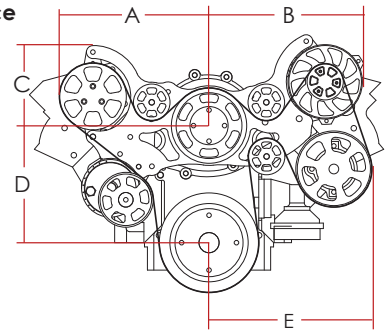

### IMPORTANT - THIS KIT REQUIRES:

- 1969-1977 11-Bolt Timing Cover

## STANDARD POLISHED KITS

Standard polished 326-455 Pontiac Tru Trac includes the following:

- Polished aluminum pulleys & brackets
- Polished billet tensioner (Tru Trac exclusive)
- Polished 140 amp Powermaster 1-wire alternator
- Natural finish Edelbrock reverse rotation water pump

### Kits with AC Include:

- Polished Sanden SD-7 compressor
- Polished AC clutch cover
- Patented polished billet compressor manifold

### Kits with power steering include:

- Natural finish power steering pump with AN nipples
- Polished power steering pulley



With AC  
With Power Steering  
#14900



With AC  
Without Power Steering  
#14920



Without AC  
With Power Steering  
#14905



Without AC  
Without Power Steering  
#14925

# PREMIUM KITS



Premium 326–455 Pontiac Tru Trac includes the following:

- Polished aluminum pulleys & brackets
- Polished billet tensioner (Tru Trac exclusive)
- Polished 140 amp Powermaster 1-wire alternator or polished billet machined case 140 amp alternator
- Natural finish Edelbrock reverse rotation water pump

**Kits with AC include:**

- Polished Sanden SD-7 compressor
- Polished AC clutch cover
- Patented polished billet compressor manifold

**Kits with power steering include:**

- Polished finish power steering pump with AN nipples
- Polished power steering pulley



**With AC  
With Power Steering**

With Polished P/S Pump

**#14900P**

With Polished P/S Pump  
Polished 140 Amp  
Billet Alternator  
**#14900PA**



**With AC  
Without Power Steering**

With Polished 140 Amp  
Billet Alternator

**#14920A**



**Without AC  
With Power Steering**

With Polished P/S Pump

**#14905P**

With Polished P/S Pump  
Polished 140 Amp  
Billet Alternator  
**#14905PA**



**Without AC  
Without Power Steering**

With Polished 140 Amp  
Billet Alternator

**#14925A**

# PREMIUM BLACK ANODIZED KITS

With Polished P/S Pump

**#BLK14900P**

With Polished P/S Pump & Polished  
140 Amp Billet Alternator

**#BLK14900PA**

*\* Includes all the upgrades from the premium kits above, with black anodized pulleys, brackets, and tensioner\**

# BLACK ANODIZED KITS

Black anodized 326–455 Pontiac Tru Trac includes the following:

- Black anodized aluminum pulleys & brackets
- Black anodized billet tensioner (Tru Trac exclusive)
- Polished 140 amp Powermaster 1-wire alternator
- Natural finish Edelbrock reverse rotation water pump

**Kits with AC include:**

- Polished Sanden SD-7 compressor
- Black anodized AC clutch cover
- Patented black anodized billet compressor manifold

**Kits with power steering include:**

- Natural finish power steering pump with AN nipples
- Black anodized power steering pulley



**With AC  
With Power Steering  
#BLK14900**



**With AC  
Without Power Steering  
#BLK14920**



**Without AC  
With Power Steering  
#BLK14905**



**Without AC  
Without Power Steering  
#BLK14925**

# TRU TRAC UPGRADES & ADD-ONS

## 140 AMP BILLET ALUMINUM ALTERNATOR

Truly the crown jewel of alternators, Billet Specialties 3D machines the entire alternator case from 6061-T6 billet aluminum optimizing airflow for cooling while adding our unmistakable style. Each alternator is then assembled with quality new Powermaster internals and dyno tested to ensure superior performance. Available in polished or black anodized finish.

### Product Features:

- 140 amp 1-wire hook-up
- Proof-of-Performance tag included
- Gold plated terminal post

### Designed for use with:

- Billet Specialties Tru Trac serpentine kits

### Not for use with:

- V-Trac Pulley Systems
- FM brackets or bracket kits
- Independent brackets

#12050 Polished  
#BLK12050 Black Anodized

140 AMP

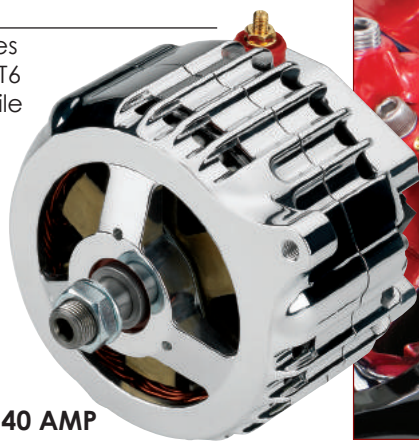

## REPLACEMENT POWERMASTER ALTERNATOR

For All Tru Trac Serpentine Kits

### Product Features:

- 140 amp 1-wire hook-up
- Polished Powermaster alternator
- Gold-plated terminal post

### Designed for use with:

- Billet Specialties Tru Trac serpentine kits

### Not for use with:

- V-Trac Pulley Systems
- FM brackets or bracket kits
- Independent brackets

#12045 Polished  
\* Pulley not included \*

140 AMP

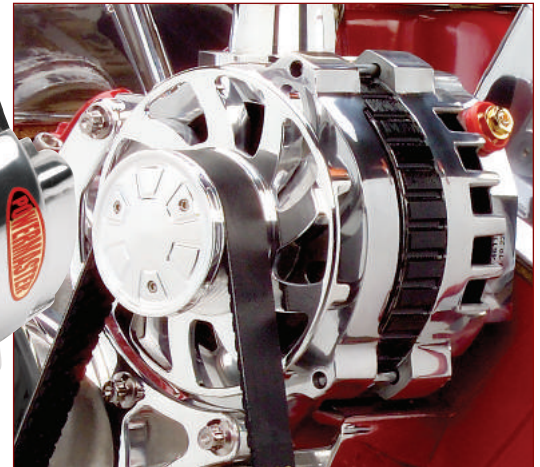

## EDELBRÖCK ENDURASHINE™ WATER PUMP

### What is EnduraShine™?

It's an amazing finish that has the brilliance of chrome or a well-polished piece, without the maintenance or the high price tag. This revolutionary new coating won't fade or oxidize and cleans up easily with soap and water.

### Designed for use with:

- Chevrolet® Tru Trac Serpentine Kits
- For Small / Big Block & 348/409 kits only

#12030 Small Block Chevy\*  
#12035 Big Block Chevy\*  
#12037 348/409 Chevy\*

\* Reverse rotation water pump for Tru Trac only \*

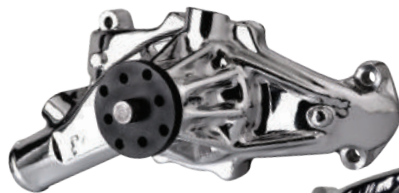

## POWER STEERING ADD-ON KITS FOR TRU TRAC SERPENTINE KITS



### Designed for use with:

- Billet Specialties Tru Trac Serpentine Kits

### Not for use with:

- V-Trac Pulley Systems
- FM or Independent brackets

### Kits Include:

- Natural finish power steering pump
- Polished billet aluminum power steering pulley (installed)
- Polished billet aluminum bracket
- Continental Elite serpentine belt
- Stainless mounting hardware

CHEVROLET®		
Engine Type	Tru Trac #	P/S Add-On #
Small Block	w AC #13120	#13320
Small Block	w/o AC #13125	#13325
Big Block	w AC #14120	#14320
Big Block	w/o AC #14125	#14325
348/409	w AC #14420	#14430
348/409	w/o AC #14425	#14435
LS - Top Mount	w AC #13470	#13480
LS - Top Mount	w/o AC #13475	#13485
LS7 - Top Mount	w AC #13490	#13480
LS7 - Top Mount	w/o AC #13495	#13485

FORD		
Engine Type	Tru Trac #	P/S Add-On #
Small Block	w AC #13620	#13630
Big Block	w AC #14620	#14630
Big Block	w/o AC #14625	#14635
FE	w AC #14720	#14730
FE	w/o AC #14725	#14735

CHRYSLER		
Engine Type	Tru Trac #	P/S Add-On #
Small Block	w AC #13820	#13830
Small Block	w/o AC #13825	#13835
Big Block/HEMI	w AC #14820	#14830
Big Block/HEMI	w/o AC #14825	#14835

PONTIAC		
Engine Type	Tru Trac #	P/S Add-On #
326-455	w AC #14920	#14930
326-455	w/o AC #14925	#14935



\* Only works with SB-BBC Tru Trac, V-Trac & FM Serpentine Conversion Kits \*

### PUMP MOUNT BILLET RESERVOIR

Billet Specialties pump mount billet reservoir is a machining marvel with innovative features such as threaded double O-ring reservoir and hose attachments providing secure leak free service. Precision machined internal baffling eliminates foaming and is topped off with a vented notch grip cap to match our other accessories.

### Product Features:

- Precision 3D Machined
- Vented fill cap with dipstick
- 6061-T6 billet aluminum
- High fluid capacity

#77930 Polished  
#BLK77930 Black

### GM TYPE II P/S FLOW CONTROL VALVE

Solves quick or "twitchy" steering by replacing the supplied valve and reducing the flow of GM type II power steering pumps from 3.5 GPM to 2 GPM which is recommended for Mustang II rack & pinion steering.

#RP1300



### FORD SMALL BLOCK BILLET DIPSTICK & BRACKET ASSEMBLY FOR USE WITH FRONT SUMP OIL PANS ONLY



Designed for use with the Tru Trac Ford billet timing cover only. Features easy to read level markings and stainless steel braided cover with Teflon inner tube.

#40150

**FOR ADDITIONAL TRU TRAC ACCESSORIES, SEE PAGE 41**

# V-TRAC PULLEY SYSTEMS

CHEVROLET®

## V-Trac: The Most Complete V-Belt Pulley System Available

The V-Trac offers quality components and ease of installation in a compact package. We take the guesswork out of assembling an engine accessory drive by providing an all inclusive kit that includes all the components, brackets and hardware from some of the best brands in the automotive aftermarket. The V-Trac works with any cylinder head and manifold combination while allowing installation in the most compact engine compartments. Best of all, the V-Trac features Billet Specialties quality.

## BILLET A/C MANIFOLD

Kits with AC include our billet aluminum AC manifold, engineered not only to provide an efficient attachment point for the AC hoses, but to look good as well. In fact, so good and efficient we patented it!



## EDELBROCK WATER PUMP

Designed and cast in the USA, Edelbrock water pumps provide maximum pressure and equal distribution to both sides of the block within 1%.

## STAINLESS STANDOFFS

Our stainless stand-offs provide the most rigid platform in the industry, while maintaining perfect alignment between the accessories. Machined from 303 stainless steel to provide corrosion resistance and double the surface area while adding ease of assembly.



## FASTENERS

V-Trac kits are assembled with 18-8 stainless steel fasteners, offering not only corrosion resistance, but professional appearance and high tensile strength. ARP 12pt. fasteners also match many other Billet Specialties accessories.

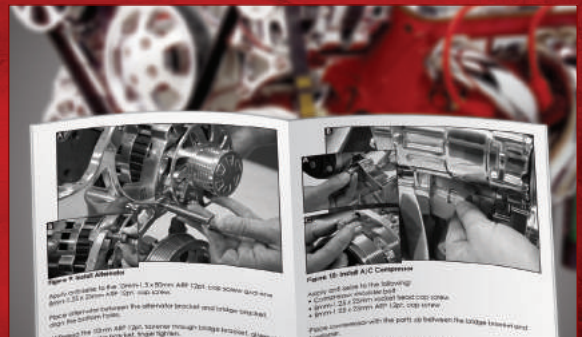

## EASE OF INSTALLATION

With our comprehensive instruction booklet and pre-installed alternator and power steering pulleys, installing a V-Trac is easy.

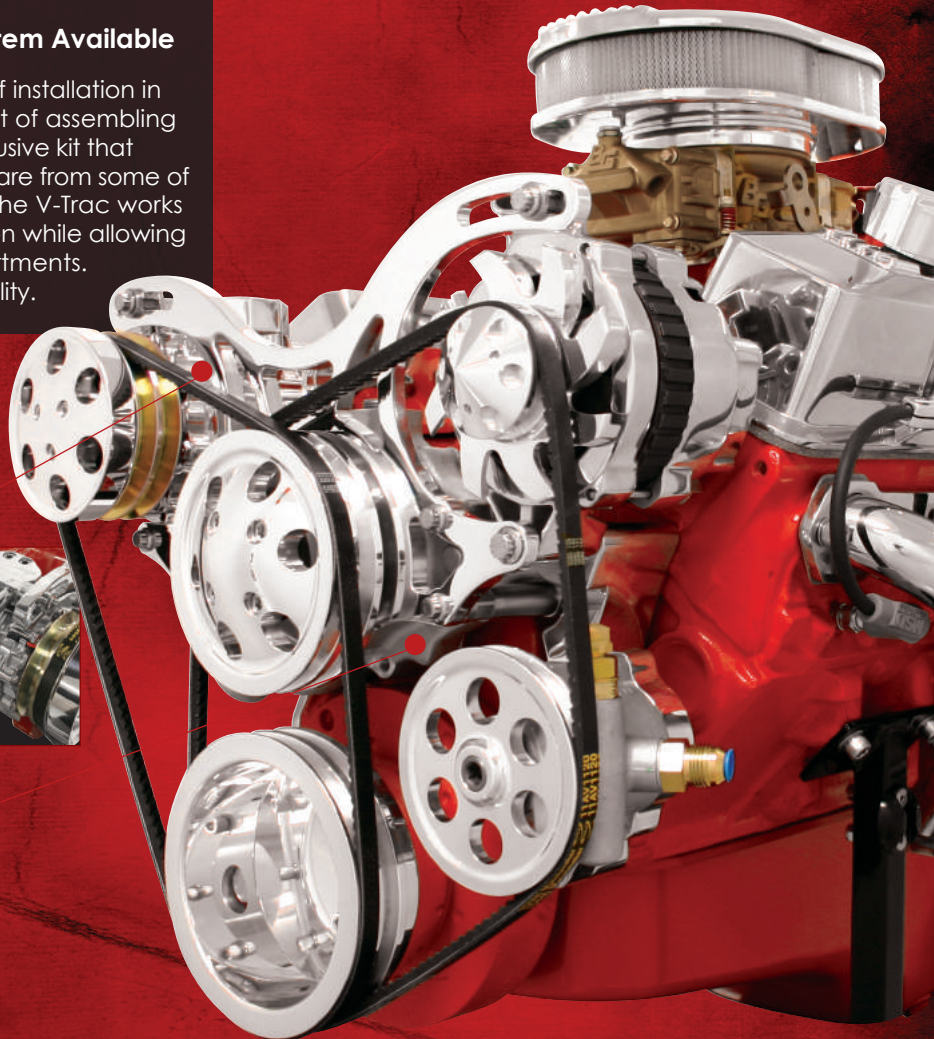

Featuring the best brands in aftermarket performance:



## SMALL BLOCK CHEVROLET®

Standard polished Small Block Chevrolet® V-Trac includes the following:

- Polished aluminum pulleys & brackets
- Polished 105 amp 1-wire alternator
- Natural finish Edelbrock water pump
- Continental Elite Poly V-belts
- Polished Sanden SD-7 compressor
- Polished AC clutch cover
- Patented polished billet compressor manifold

**Kits with power steering include:**

- Natural finish power steering pump with AN nipples
- Polished power steering pulley



With AC  
With Power Steering  
#V3220

With AC  
Without Power Steering  
#V3120

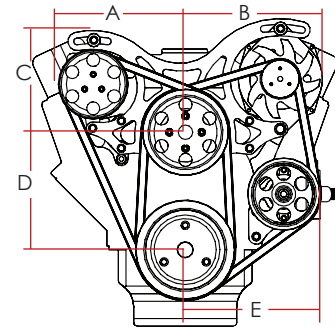

**Dimensions - Small Block Chevy™**

To Front Face Of	From Block Face
AC Compressor Cover	7.500"
Alternator Pulley	6.500"
Water Pump Pulley	7.000"
Power Steering Pulley	6.325"
Crankshaft Pulley	6.250"

\* Check Clearances Before Ordering \*  
Replacement O-Ring Kit Available - #RP1320 For Small Block Chevy Tru Trac & V-Trac

A: 9.50" D: 7.00"  
B: 9.00" E: 9.00"  
C: 7.75"

## BIG BLOCK CHEVROLET®

Standard polished Big Block Chevrolet® V-Trac includes the following:

- Polished aluminum pulleys & brackets
- Polished 105 amp 1-wire alternator
- Natural finish Edelbrock water pump
- Continental Elite Poly V-belts
- Polished Sanden SD-7 compressor
- Polished AC clutch cover
- Patented polished billet compressor manifold

**Kits with power steering include:**

- Natural finish power steering pump with AN nipples
- Polished power steering pulley



With AC  
With Power Steering  
#V4220

With AC  
Without Power Steering  
#V4120

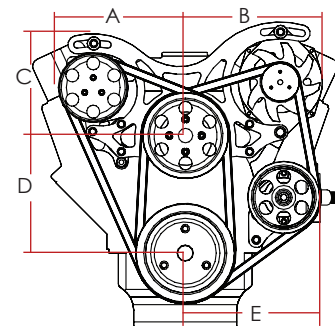

**Dimensions - Big Block Chevy™**

To Front Face Of	From Block Face
AC Compressor Cover	7.625"
Alternator Pulley	6.625"
Water Pump Pulley	7.125"
Power Steering Pulley	6.500"
Crankshaft Pulley	6.375"

\* Check Clearances Before Ordering \*  
\*V-Trac systems are not designed for use with hydroboost brake systems\*  
Replacement O-Ring Kit Available - #RP1420 For Big Block Chevy Tru Trac & V-Trac

A: 10.00" D: 7.125"  
B: 9.00" E: 9.50"  
C: 8.50"

# V-TRAC UPGRADES & ADD-ONS

## FOR V-TRAC PULLEY SYSTEMS

### Designed for use with:

- V-Trac Pulley systems

### Not for use with:

- Tru Trac Serpentine Kits
- FM or Independent brackets

### Kits Include:

- Natural finish power steering pump
- Polished billet aluminum power steering pulley (installed)
- Polished billet aluminum bracket
- Continental Elite Poly V-belts
- Stainless mounting hardware

#V3320 Small Block Chevy  
#V4320 Big Block Chevy



We pre-installed the pulley for you!

## REPLACEMENT V-TRAC ALTERNATOR

### Product Features:

- 105 amp 1-wire hook-up
- Gold plated terminal post
- GM 10SI/12SI Case
- New - not rebuilt case and internals

### For use with:

- Billet Specialties V-Trac Pulley System

### Also will work with:

- FM Brackets or FM Serpentine Conversion Kits
- Independent Alternator Brackets

#V0105 Polished



## REPLACEMENT POWER STEERING PUMPS

### Product Features:

- Flow rate: 3.5GPM @ 1200PSI
- Cad plated AN fittings pre-installed
- New pump (not remanufactured)

#12020 Natural  
#12025 Polished

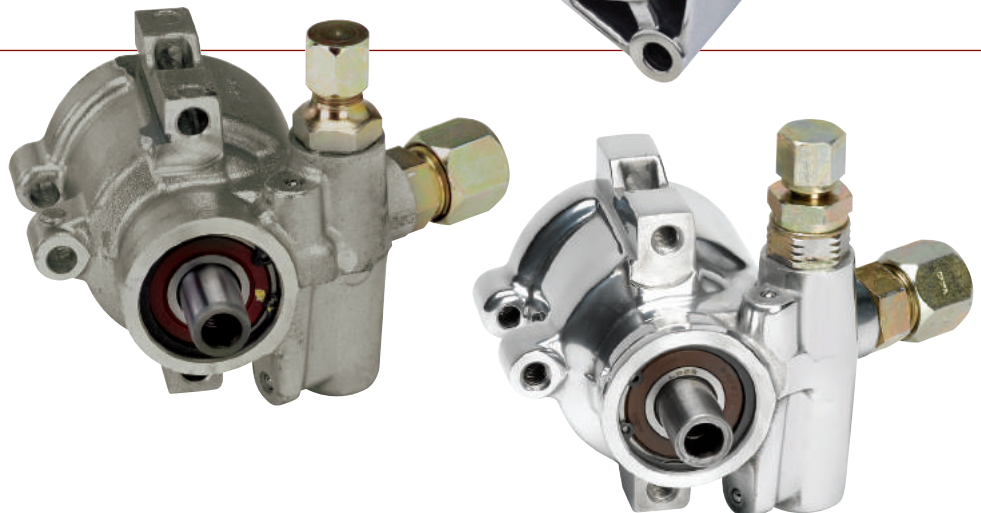



# RECOMMENDED ACCESSORIES

## FOR V-TRAC & TRU TRAC



### PUMP MOUNT BILLET RESERVOIR

Billet Specialties pump mount billet reservoir is a machining marvel with innovative features such as threaded double O-ring reservoir and hose attachments providing secure leak free service. Precision machined internal baffling eliminates foaming and is topped off with a vented notch grip cap to match our other accessories.

#77930 Polished  
#BLK77930 Black

\* Only works with SB-BBC Tru Trac, V-Trac & FM Serpentine Conversion Kits \*



### REMOTE POWER STEERING RESERVOIR

The double O-ring sealed breathable cap relieves positive and negative pressure while keeping your engine compartment clean. Forget foaming and fluid turbulence with our innovative internal return tube. Includes male AN fittings on the bottom of the reservoir. Our exclusive bracket design clamps to the reservoir with an internal lock. The mounting hardware is completely hidden!

77910 Smooth  
#77920 Ribbed  
#BLK77910 Black

### POWER STEERING HOSE KIT FOR PUMP MOUNT RESERVOIR

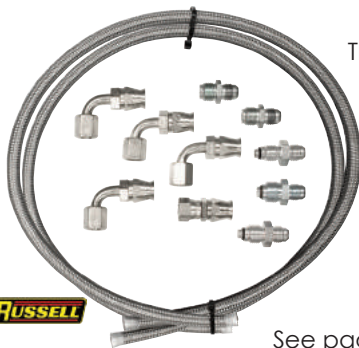

The perfect accessory to our pump mount reservoir takes the guesswork out of power steering lines. All this in one kit includes hose, fittings and adapters for the most popular power steering racks and boxes.

RUSSELL

#77905

See page 56 for more information.

### POWER STEERING HOSE KIT FOR REMOTE RESERVOIR



The perfect accessory to our remote reservoir takes the guesswork out of power steering lines. All this in one kit includes hose, fittings and adapters for the most popular power steering racks and boxes.

RUSSELL

#77900

See page 57 for more information.



### POWER STEERING ADAPTER KIT

#### Applications:

- '77-'78 Mustang II rack & pinion
- Up to '88 T-Bird rack & pinion
- Maval Mfg. rack & pinion
- Saginaw 600 steering gear box

#77901



### RESERVOIR TIGHT FIT KIT

Kit includes -6 & -10 90° AN fittings for use with our billet remote reservoirs when available space does not allow for the use of straight fittings.

#77902



### 2GPM FLOW CONTROL VALVE

Reduce the flow of GM type II power steering pumps from 3.5 GPM to 2 GPM which is recommended for Mustang II rack & pinion steering.

#RP1300

# SERPENTINE CONVERSION KITS

## SMALL BLOCK CHEVROLET® - TOP MOUNT

### SMALL BLOCK CHEVROLET® Top Mount - Alternator Only Kit

**NOW AVAILABLE IN BLACK!**

#### Designed for use with:

- Long water pump
- GM 10SI / 12SI alternator

✓ **Pulley Nose Cones - Included!**

✓ **Stainless Hardware - Included!**

Top mount passenger side alternator bracket, alternator pulley with fan and nose cone. Water pump pulley with nose cone and crank pulley. Stainless steel hardware is included.

#FM2110PC  
#BLKFM2110

Top Mount-Alt Only Polished  
Top Mount-Alt Only Black

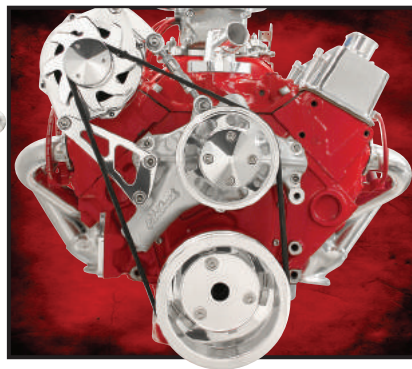

### SMALL BLOCK CHEVROLET® Top Mount - Alternator & Power Steering Kit

**NOW AVAILABLE IN BLACK!**

#### Designed for use with

- Long water pump
- GM 10SI / 12SI alternator
- Saginaw power steering pump

✓ **Pulley Nose Cones - Included!**

✓ **Stainless Hardware - Included!**

Top mount passenger side alternator bracket, alternator pulley with fan and nose cone. Water pump pulley with nose cone and crank pulley. Power steering pump bracket and pulley. Stainless steel hardware included.

#FM2111PC  
#FM2112PC  
#BLKFM2111  
#BLKFM2112

Keyway Shaft Power Steering Pump Polished  
Press-on Shaft Power Steering Pump Polished  
Keyway Shaft Power Steering Pump Black  
Press-on Shaft Power Steering Pump Black

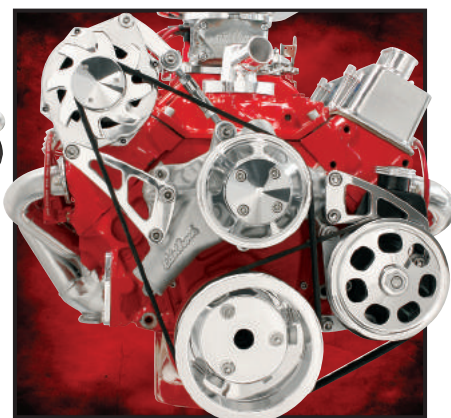

### SMALL BLOCK CHEVROLET® A/C add-on Kit For Top or Mid-Mount - Alternator, AC & Power Steering Kit

In an effort to simplify things while providing the ability to add A/C to an existing kit purchased without A/C Bracket. Billet specialties now offers the A/C add-on kit separately.

Includes: Alternator Bracket, Turn Buckle, Idler Pulley and Compressor Clutch cover

#FM1320PC Serpentine Conversion Kit - SBC A/C Add-On Polished  
#BLKFM1320 Serpentine Conversion Kit - SBC A/C Add-On Black

#### Fits the following part numbers:

FM2111PC & FM2112PC Top Mount-Alternator & Power Steering Kit  
FM2121PC & FM2122PC Mid Mount-Alternator & Power Steering Kit

**Important: This kit only works with above listed kits**



### KNOW THE DIFFERENCE...

Our Serpentine Conversion Kits give you much more for less money. All with genuine Billet Specialties quality!

#### Billet Specialties Serpentine Conversion Kits:

- Mirror Polished Finish
- Stainless Steel Hardware Included
- Polished Stainless Steel Turnbuckles
- Nose Cones included on Alternator, Water Pump, & Idler Pulleys
- Comprehensive Installation Instructions
- CNC machined billet stylized pulley design - At No Extra Charge
- Exclusive dual idler pulley system for A/C kits to keep belt tension

#### Their Bracket Kits:

- Machine Finish
- Zinc Plated Steel Hardware
- Raw Stainless Finish Turnbuckles
- Nose Cones Sold Separately
- Single Diagram
- Blank, plain-faced pulleys
- Single idler pulley allows belt slacking

# SERPENTINE CONVERSION KITS

## SMALL BLOCK CHEVROLET® - MID MOUNT

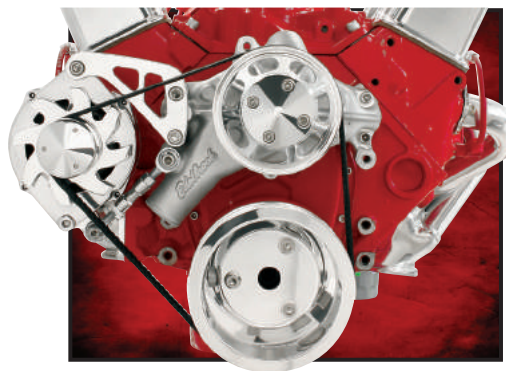

**NOW AVAILABLE IN BLACK!**

**SMALL BLOCK CHEVROLET®**  
Mid Mount - Alternator Only Kit

- ✓ Pulley Nose Cones - Included!
- ✓ Stainless Hardware - Included!

- Designed for use with:
- Long water pump
  - GM 10SI / 12SI alternator

Mid mount passenger side alternator bracket, alternator pulley with fan and nose cone. Water pump pulley with nose cone and crank pulley. Stainless steel hardware is included.

#FM2120PC Mid Mount-Alt Only Polished  
#BLKFM2120 Mid Mount-Alt Only Black

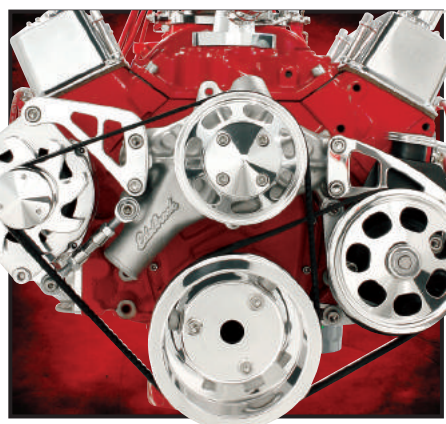

**NOW AVAILABLE IN BLACK!**

**SMALL BLOCK CHEVROLET®**  
Mid Mount - Alternator & Power Steering Kit

- ✓ Pulley Nose Cones - Included!
- ✓ Stainless Hardware - Included!

- Designed for use with:
- Long water pump
  - GM 10SI / 12SI alternator
  - Saginaw power steering pump

Mid mount passenger side alternator bracket, alternator pulley with fan and nose cone. Water pump pulley with nose cone and crank pulley. Power steering pump bracket and pulley. Stainless steel hardware included.

#FM2121PC Keyway Shaft Power Steering Pump Polished  
#FM2122PC Press-on Shaft Power Steering Pump Polished  
#BLKFM2121 Keyway Shaft Power Steering Pump Black  
#BLKFM2122 Press-on Shaft Power Steering Pump Black

### TECH TIP: STAINLESS VS. ZINC PLATED

Billet Specialties knows why you replace the factory accessories on your car. We'll help you improve your style and performance with the highest quality components available. We never skimp on the details and that's why you get stainless steel hardware with every Billet Specialties pulley and bracket kit.

Even new vehicles are equipped with stainless hardware. The fact is - zinc-plated steel doesn't stand up to vehicle manufacturer's tests for strength and durability. Stainless steel beats zinc hands down in looks, performance and quality. Billet Specialties supplies the best because you demand it!



**Small Block Chevrolet®**  
Mid Mount - Alternator & Power Steering Kit



**DON'T FORGET THIS!**

### Power Steering Cap Cover

Easy to install, attaches to factory cap with a set-screw. 1.94" I.D.

#89120

# SERPENTINE CONVERSION KITS

## BIG BLOCK CHEVROLET® - TOP MOUNT

### BIG BLOCK CHEVROLET®

**NOW AVAILABLE IN BLACK!**

#### Top Mount - Alternator Only Kit

##### Designed for use with:

- Long water pump
  - GM 10SI / 12SI alternator
- ✓ Pulley Nose Cones - Included!  
✓ Stainless Hardware - Included!

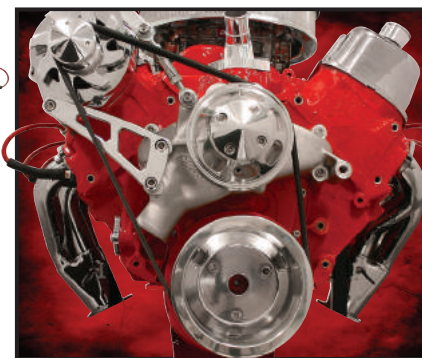

Top mount passenger side alternator bracket, alternator pulley with fan and nose cone. Water pump pulley with nose cone and crank pulley. Stainless steel hardware is included.

#FM2210PC  
#BLKFM2210

Top Mount-Alt Only Polished  
Top Mount-Alt Only Black

### BIG BLOCK CHEVROLET®

**NOW AVAILABLE IN BLACK!**

#### Top Mount - Alternator & Power Steering Kit

##### Designed for use with:

- Long water pump
  - GM 10SI / 12SI alternator
  - Saginaw power steering pump
- ✓ Pulley Nose Cones - Included!  
✓ Stainless Hardware - Included!

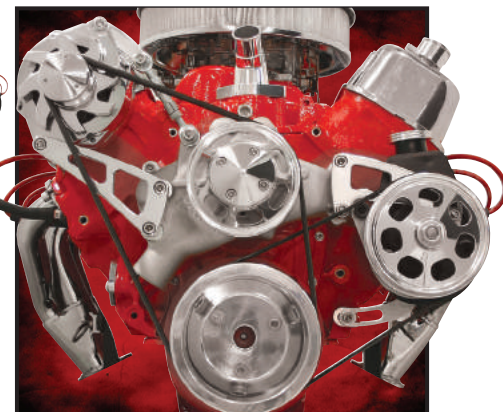

Top mount passenger side alternator bracket, alternator pulley with fan and nose cone. Water pump pulley with nose cone and crank pulley. Power steering pump bracket and pulley. Stainless steel hardware included.

#FM2211PC  
#FM2212PC  
#BLKFM2211  
#BLKFM2212

Keyway Shaft Power Steering Pump Polished  
Press-on Shaft Power Steering Pump Polished  
Keyway Shaft Power Steering Pump Black  
Press-on Shaft Power Steering Pump Black

### BIG BLOCK CHEVROLET® A/C add-on Kit

#### For Top or Mid-Mount - Alternator, AC & Power Steering Kit

In an effort to simplify things while providing the ability to add A/C to an existing kit purchased without A/C Bracket. Billet specialties now offers the A/C add-on kit separately.

Includes: Alternator Bracket, Turn Buckle, Idler Pulley and Compressor Clutch cover

#FM1325PC Serpentine Conversion Kit - BBC A/C Add-On Polished  
#BLKFM1325 Serpentine Conversion Kit - BBC A/C Add-On Black

##### Fits the following part numbers:

FM2211PC & FM2212PC Top Mount-Alternator & Power Steering Kit  
FM2221PC & FM2222PC Mid Mount-Alternator & Power Steering Kit

Important: This kit only works with above listed kits



### DON'T FORGET THIS!

#### POWER STEERING PUMPS - KEYWAY or PRESS-ON?

Billet Specialties serpentine conversion kits and FM brackets are designed to work with the following Saginaw power steering pumps.

#### Saginaw Power Steering Pump:

- 1/8" Keyway Shaft: Up to 1975
- Press-On Shaft: 1975 & up

# SERPENTINE CONVERSION KITS

**BIG BLOCK CHEVROLET® - MID MOUNT**

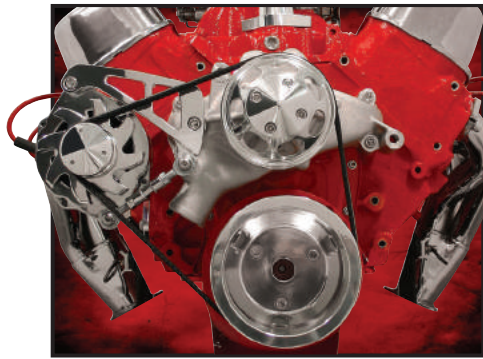

**NOW AVAILABLE IN BLACK!**

**BIG BLOCK CHEVROLET®**  
Mid Mount - Alternator Only Kit

- ✓ Pulley Nose Cones - Included!
- ✓ Stainless Hardware - Included!

- Designed for use with:
- Long water pump
  - GM 10SI / 12SI alternator

Mid mount passenger side alternator bracket, alternator pulley with fan and nose cone. Water pump pulley with nose cone and crank pulley. Stainless steel hardware is included.

#FM2220PC  
#BLKFM2220

Mid Mount-Alt Only Polished  
Mid Mount-Alt Only Black



**NOW AVAILABLE IN BLACK!**

**BIG BLOCK CHEVROLET®**  
Mid Mount - Alternator & Power Steering Kit

- ✓ Pulley Nose Cones - Included!
- ✓ Stainless Hardware - Included!

- Designed for use with:
- Long water pump
  - GM 10SI / 12SI alternator
  - Saginaw power steering pump

Mid mount passenger side alternator bracket, alternator pulley with fan and nose cone. Water pump pulley with nose cone and crank pulley. Power steering pump bracket and pulley. Stainless steel hardware included.

#FM2221PC  
#FM2222PC  
#BLKFM2221  
#BLKFM2222

Keyway Shaft Power Steering Pump Polished  
Press-on Shaft Power Steering Pump Polished  
Keyway Shaft Power Steering Pump Black  
Press-on Shaft Power Steering Pump Black

## DO IT RIGHT!

All Billet Specialties Tru Trac, V-Trac and Serpentine Conversion kits are designed for the most rigid final assembly in the industry. Here is why:

### STRENGTH

By using solid stainless stand-offs and threaded block mounting studs - rather than long bolts through a saw-cut tubing spacer - flex, fatigue and failure are non-existent.

### PRECISION

Our stand-offs are designed for precise positioning and alignment of components, not just "spacing". Each stand-off is CNC machined within .002" - a tolerance that cannot be met with saw-cut tubing.

### DOUBLE THE SURFACE AREA

Stand-offs have over twice the contact surface area compared to a cut piece of tubing. With two times more thread engagement, stand-offs ensure greater clamping force.

### CORROSION RESISTANCE

Stainless steel stand-offs and hardware resist corrosion compared to mild steel and zinc plated fasteners.

### EASE OF ASSEMBLY

Stand-offs enable straight forward assembly allowing you to install the water pump before the accessory bracket. Each piece goes together in a logical order. No component / bracket / fastener juggling or balancing acts required.

**BILLET SPECIALTIES**  
STAINLESS STAND-OFF

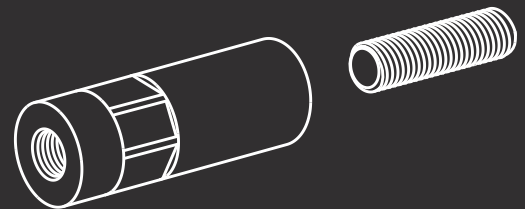

VS.



**COMPETITORS**  
CUT TUBING SPACER

**ABSOLUTELY THE STRONGEST, MOST RIGID METHOD. PERIOD.**

# ACCESSORY BRACKETS

## SMALL BLOCK CHEVROLET® - (LONG WATER PUMP)

### SMALL BLOCK CHEVROLET®

#### Top Mount - Alternator Only Bracket

##### Designed for use with:

- Long water pump
- GM 10SI / 12SI alternator
- V-groove pulleys (See pages 53-54) or Serpentine pulleys (See page 52)

##### Kit Includes:

Top mount passenger side alternator bracket & stainless steel hardware.

#FM0109PC

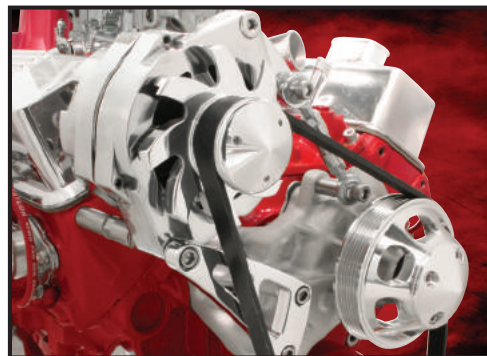

### SMALL BLOCK CHEVROLET®

#### Mid Mount - Alternator Only Bracket

##### Designed for use with:

- Long water pump
- GM 10SI / 12SI alternator
- V-groove pulleys (See pages 53-54) or Serpentine pulleys (See page 52)

##### Kit Includes:

Mid mount passenger side alternator bracket & stainless steel hardware.

#FM0107PC

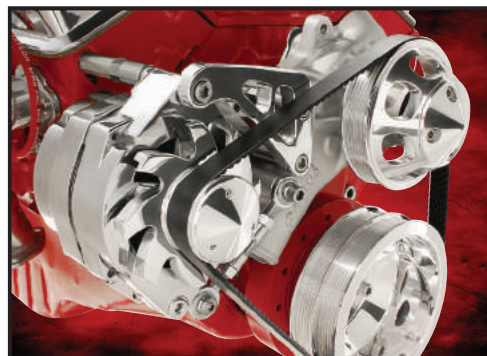

### SMALL BLOCK CHEVROLET®

#### Saginaw Power Steering Pump Bracket

##### Designed for use with:

- Long water pump
- Saginaw power steering pump
- V-groove pulleys (pages 53-54) or Serpentine pulleys (page 52)

##### Kit Includes:

Driver side power steering pump bracket & stainless steel hardware.

#FM0130PC



### SMALL BLOCK CHEVROLET®

#### GM Type II Power Steering Bracket & Pulley kit

##### Designed for use with:

- Long water pump
- External reservoir or Billet Specialties pump mount reservoir

##### Kit Includes:

New polished 1200psi GM type II pump. Pre-installed power steering pulley with AN fittings, bracket & stainless steel hardware.

#FM1220PC

### FOR SHORT WATER PUMP ONLY



### SMALL BLOCK CHEVROLET®

#### Low Mount - Alternator Only Bracket

##### Designed for use with:

- Short water pump
- GM 10SI / 12SI alternator
- V-groove pulleys (See page 53-54)

##### Kit Includes:

Low mount driver side alternator bracket & stainless steel hardware.

#FM0105PC

# ACCESSORY BRACKETS

## BIG BLOCK CHEVROLET® - (LONG WATER PUMP)

### BIG BLOCK CHEVROLET®

#### Top Mount - Alternator Only Bracket

##### Designed for use with:

- Long water pump
- GM 10SI / 12SI alternator
- V-groove pulleys (See pages 53-54) or Serpentine pulleys (See page 52)

##### Kit Includes:

Top mount passenger side alternator bracket & stainless steel hardware.

#FM0209PC

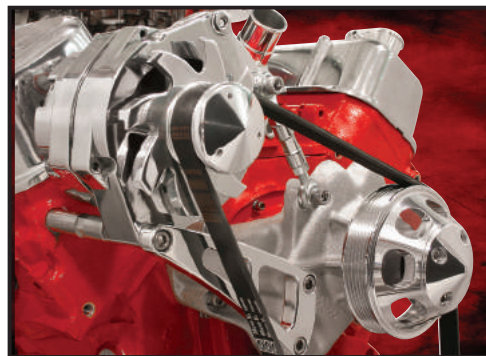

### BIG BLOCK CHEVROLET®

#### Mid Mount - Alternator Only Bracket

##### Designed for use with:

- Long water pump
- GM 10SI / 12SI alternator
- V-groove pulleys (See pages 53-54) or Serpentine pulleys (See page 52)

##### Kit Includes:

Mid mount passenger side alternator bracket & stainless steel hardware.

#FM0207PC

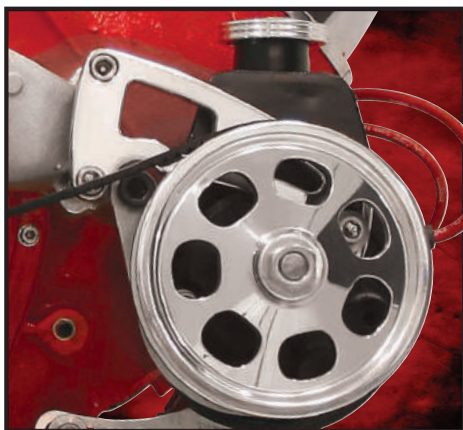
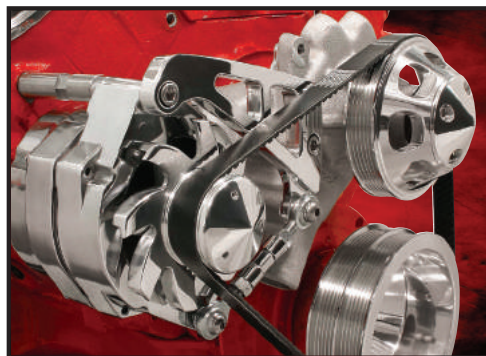

### BIG BLOCK CHEVROLET®

#### Saginaw Power Steering Pump Bracket

##### Designed for use with:

- Long water pump
- Saginaw power steering pump
- V-groove pulleys (pages 53-54) or Serpentine pulleys (page 52)

##### Kit Includes:

Driver side power steering pump bracket & stainless steel hardware.

#FM0230PC



### BIG BLOCK CHEVROLET®

#### GM Type II Power Steering Bracket & Pulley kit

##### Designed for use with:

- Long water pump
- External reservoir or Billet Specialties pump mount reservoir

##### Kit Includes:

New polished 1200psi GM type II pump. Pre-installed power steering pulley with AN fittings, bracket & stainless steel hardware.

#FM1225PC

### FOR SHORT WATER PUMP ONLY



### BIG BLOCK CHEVROLET®

#### Low Mount - Alternator Only Bracket

##### Designed for use with:

- Short water pump
- GM 10SI / 12SI alternator
- V-groove pulleys (See page 53-54)

##### Kit Includes:

Low mount driver side alternator bracket & stainless steel hardware.

#FM0205PC

# INDEPENDENT MOUNT BRACKETS

## SMALL BLOCK CHEVROLET® - (SHORT WATER PUMP)



### SMALL BLOCK CHEVROLET® Original Top Mount Air/Alternator Bracket

#### Designed for use with:

- Short water pump
- GM 10SI / 12SI alternator
- Sanden 508 AC compressor

This bracket is ideal for small block Chevrolet® motors that do not have mounting holes in the cylinder heads. The bracket mounts to the water pump and intake manifold.

Not for use with a GM compressor, superchargers, TPI, 3-deuce set-ups, or Air Gap Manifolds.

#10120

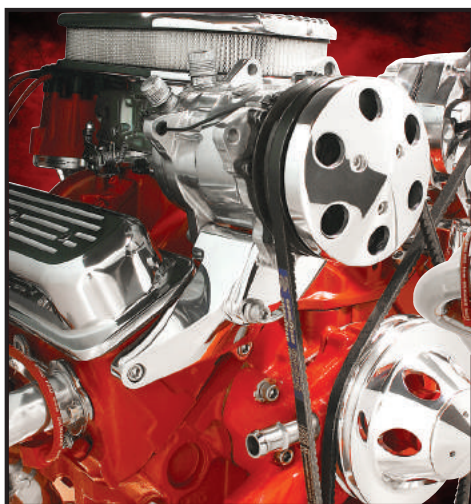

### SMALL BLOCK CHEVROLET® - VORTEC™ HEADS Independent Top Mount- Compressor Bracket

#### Designed for use with:

- Short water pump
- Sanden 508 AC compressor
- V-groove pulleys (Pages 53-54)

Mounts to the passenger side of the motor and positions the compressor to the inside of the passenger side valve cover. Independently adjustable.

#10721

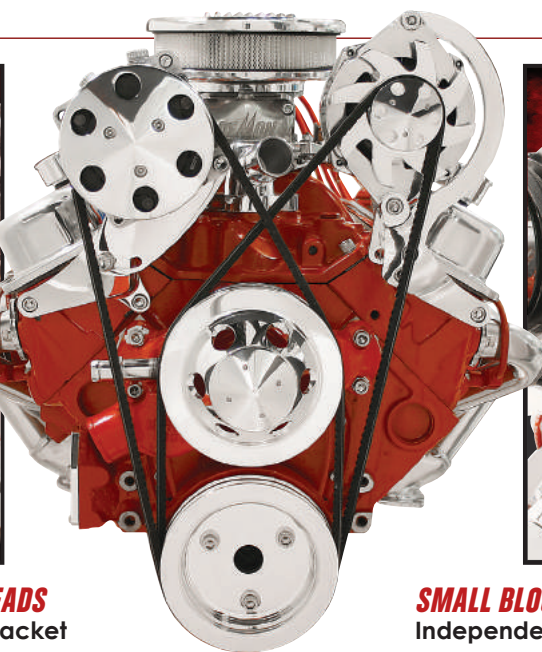

### SMALL BLOCK CHEVROLET® - VORTEC™ HEADS Independent Top Mount- Alternator Bracket

#### Designed for use with:

- Short water pump
- GM 10SI / 12SI alternators
- V-groove pulleys (Pages 53-54)

Mounts to the driver side of the motor and positions the alternator to the inside of the driver side valve cover. Independently adjustable.

#10720

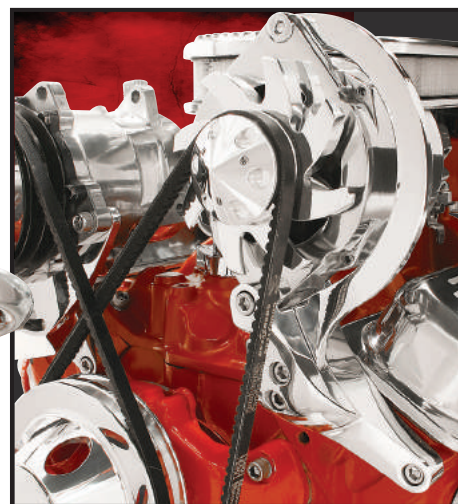

## NEED AN ALTERNATOR?



### 105 AMP GM 10SI/12SI ALTERNATOR

10SI/12SI Alternator For Independent Brackets

#### Product Features:

- 105 amp 1-wire hook-up
- Gold plated terminal
- GM 10SI/12SI Case
- New - not rebuilt case and internals

#V0105



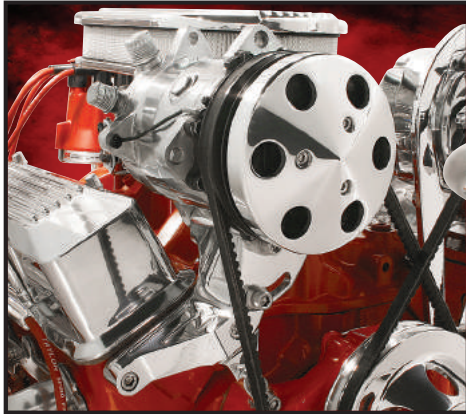

**SMALL BLOCK CHEVROLET® - STANDARD HEADS**  
Independent Top Mount- Compressor Bracket

**Designed for use with:**

- Short water pump
- Sanden 508 AC compressor
- V-groove pulleys (Pages 53-54)

Mounts to the passenger side of the motor and positions the compressor to the inside of the passenger side valve cover. Independently adjustable.

#10221

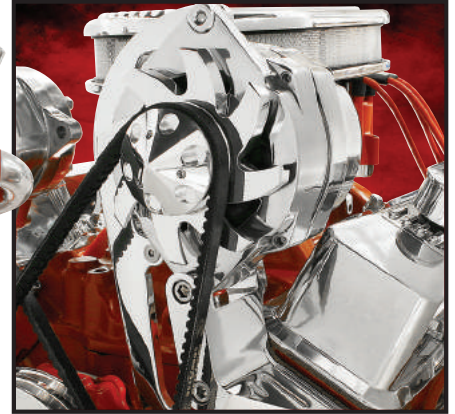
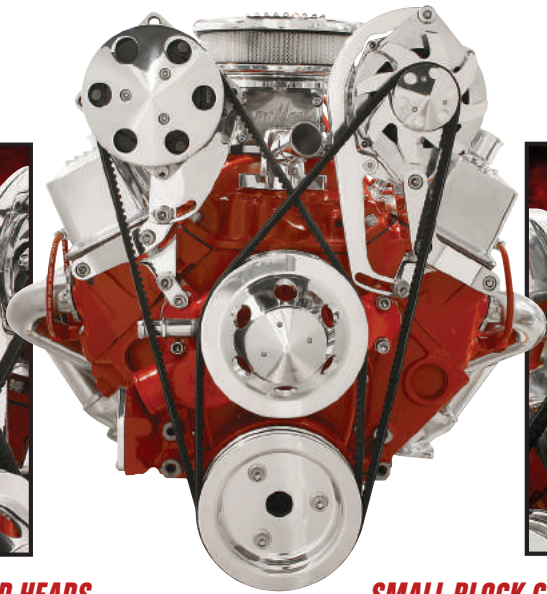

**SMALL BLOCK CHEVROLET® - STANDARD HEADS**  
Independent Top Mount- Alternator Bracket

**Designed for use with:**

- Short water pump
- GM 10SI / 12SI alternators
- V-groove pulleys (Pages 53-54)

Mounts to the driver side of the motor and positions the alternator to the inside of the driver side valve cover. Independently adjustable.

#10220

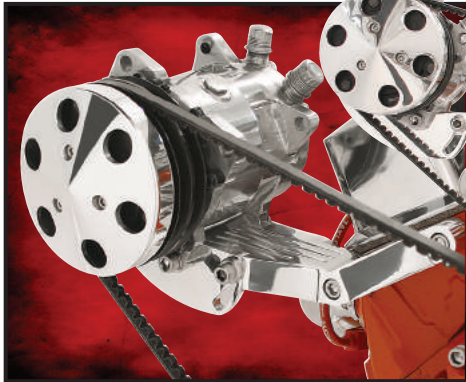

**SMALL BLOCK CHEVROLET® - STANDARD HEADS**  
Independent Side Mount- Compressor Bracket

**Designed for use with:**

- Short water pump
- Sanden 508 AC compressor
- V-groove pulleys (Pages 53-54)

Dual-point mounting to the passenger side of the motor positions the compressor to the outside of the passenger side valve cover. Independently adjustable.

#10421

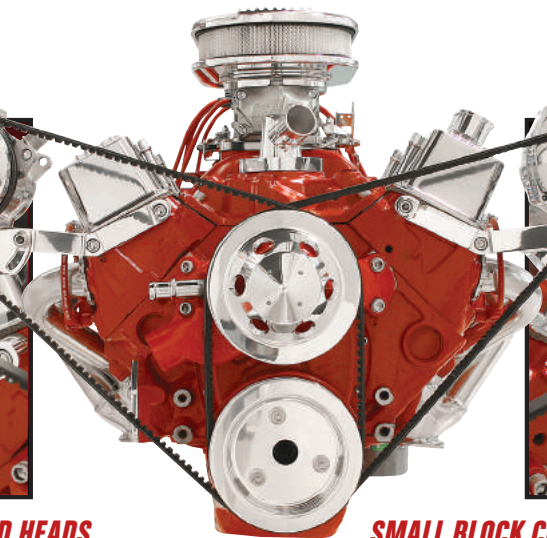

**SMALL BLOCK CHEVROLET® - STANDARD HEADS**  
Independent Side Mount- Alternator Bracket

**Designed for use with:**

- Short water pump
- GM 10SI / 12SI alternators
- V-groove pulleys (Pages 53-54)

Dual-point mounting to the driver side of the motor positions the alternator to the outside of the driver side valve cover. Independently adjustable.

#10420

# INDEPENDENT MOUNT BRACKETS

## SMALL BLOCK CHEVROLET® - (LONG WATER PUMP)

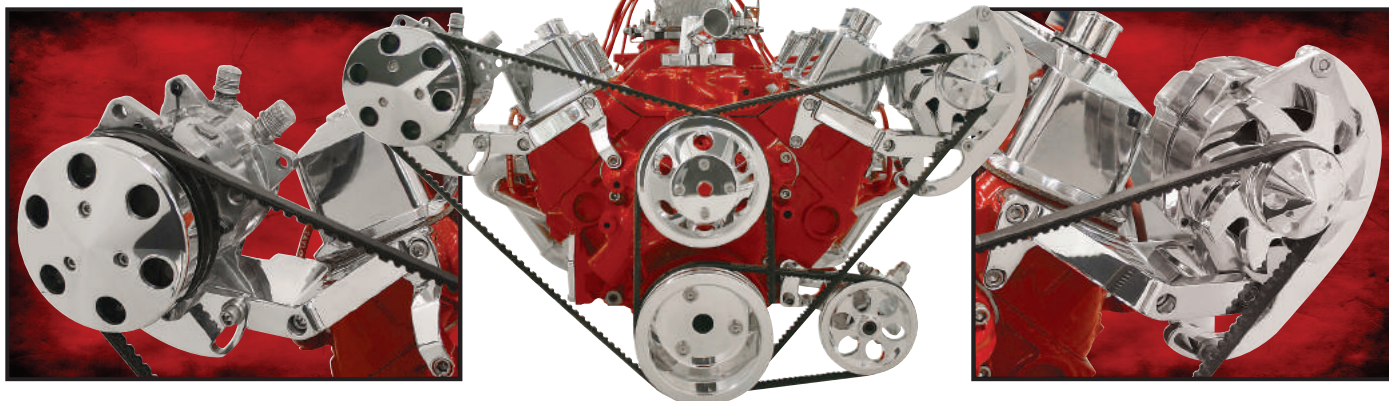

### **SMALL BLOCK CHEVROLET® - STANDARD HEADS** Independent Side Mount- Compressor Bracket

#### Designed for use with:

- Long water pump
- Sanden 508 AC compressor
- V-groove pulleys (Pages 53-54)

3-point mounting and one piece construction for extra stability. Bracket positions the compressor to the outside of the passenger side valve cover. Independently adjustable.

#11421

### **SMALL BLOCK CHEVROLET® - STANDARD HEADS** Independent Side Mount- Alternator Bracket

#### Designed for use with:

- Long water pump
- GM 10SI / 12SI alternators
- V-groove pulleys (Pages 53-54)

3-point mounting and one piece construction for extra stability. Bracket positions the alternator to the outside of the driver side valve cover. Independently adjustable.

#11420

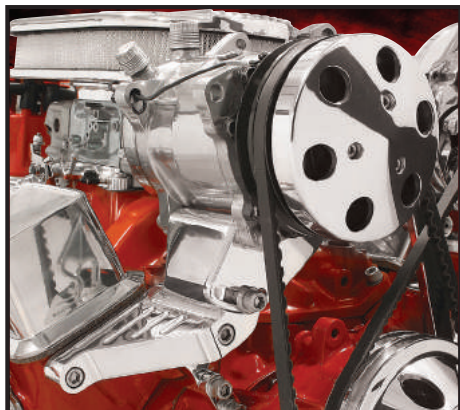

### **SMALL BLOCK CHEVROLET® - STANDARD HEADS** Independent Top Mount- Compressor Bracket

#### Designed for use with:

- Long water pump
- Sanden 508 AC compressor
- V-groove pulleys (Pages 53-54)

3-point mounting to the head and water pump position the compressor to the inside of the passenger side valve cover. Independently adjustable.

#11221

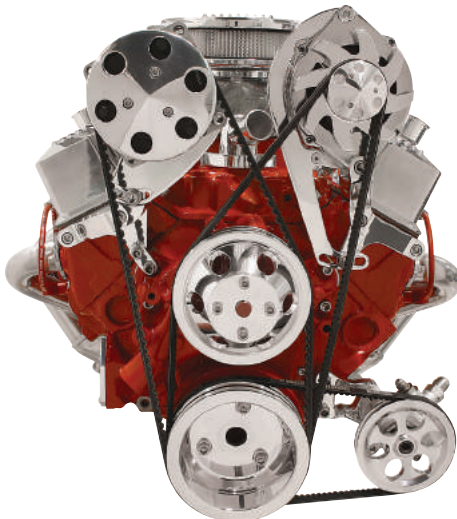

### **SMALL BLOCK CHEVROLET® - STANDARD HEADS** Independent Top Mount- Alternator Bracket

#### Designed for use with:

- Long water pump
- GM 10SI / 12SI alternators
- V-groove pulleys (Pages 53-54)

3-point mounting to the head positions the alternator to the inside of the driver side valve cover. Independently adjustable.

#11220

# INDEPENDENT MOUNT BRACKETS

**BIG-BLOCK CHEVROLET® - (SHORT WATER PUMP)**

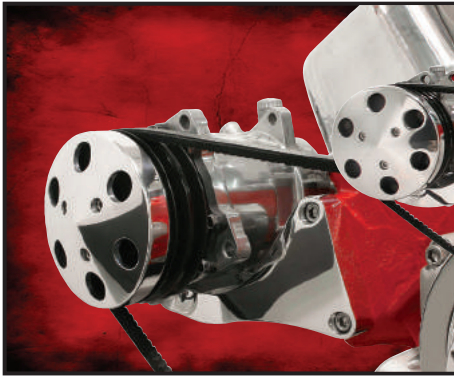

**BIG BLOCK CHEVROLET® - STANDARD HEADS**  
Independent Side Mount- Compressor Bracket

**Designed for use with:**

- Cylinder heads with 7/16" accessory bolt holes
- Short water pump
- Sanden 508 AC compressor
- V-groove pulleys (Pages 53-54)

Dual-point mounting and one piece construction for extra stability. Bracket positions the compressor to the outside of the passenger side valve cover. Independently adjustable.

#10621

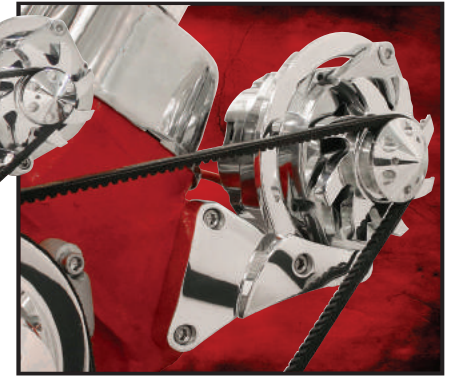

**BIG BLOCK CHEVROLET® - STANDARD HEADS**  
Independent Side Mount- Alternator Bracket

**Designed for use with:**

- Cylinder heads with 3/8" bolt holes
- Short water pump
- GM 10SI / 12SI alternators
- V-groove pulleys (Pages 53-54)

Dual-point mounting and one piece construction for extra stability. Bracket positions the alternator to the outside of the driver side valve cover. Independently adjustable.

#10620



**BIG BLOCK CHEVROLET® - STANDARD HEADS**  
Independent Top Mount- Compressor Bracket

**Designed for use with:**

- Cylinder heads with 7/16" accessory bolt holes
- Short water pump
- Sanden 508 AC compressor
- V-groove pulleys (Pages 53-54)

Dual-point mounting to the passenger side of the motor positioning the compressor to the inside of the passenger side valve cover. Independently adjustable.

#10521

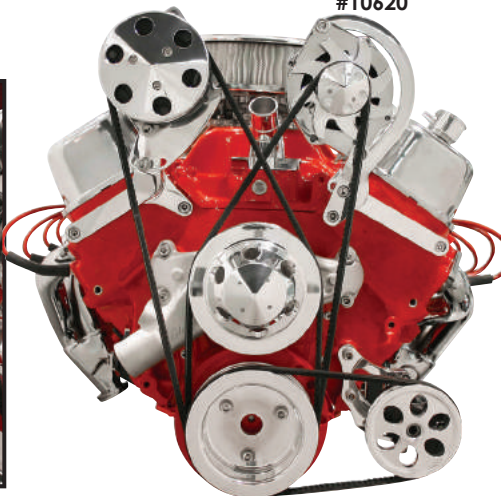

**BIG BLOCK CHEVROLET® - STANDARD HEADS**  
Independent Top Mount- Alternator Bracket

**Designed for use with:**

- Cylinder heads with 3/8" accessory bolt holes
- Short water pump
- GM 10SI / 12SI alternators
- V-groove pulleys (Pages 53-54)

Dual-point mounting to the driver side of the motor positioning the alternator to the inside of the driver side valve cover. Independently adjustable.

#10520

# BILLET PULLEYS & PULLEY KITS

## SERPENTINE

Precision machined & polished to a mirror finish, these pulleys are engineered to work with our accessory brackets. 6061-T6 construction means they are perfectly balanced and true unlike cast pulleys on the market. Stainless steel hardware is included.

### SERPENTINE PULLEY KIT FOR FM BRACKETS - LONG WATER PUMP

#### Designed for use with:

- Long water pump
- GM 10SI / 12SI alternator

#### Kit Includes:

- Alternator pulley with Fan & Nose Cone
- Water Pump Pulley with Nose Cone
- Crank Pulley
- Stainless Hardware

#### Small Block Chevrolet®

#FM3110PC Serpentine Pulley Kit

#### Big Block Chevrolet®

#FM3210PC Serpentine Pulley Kit

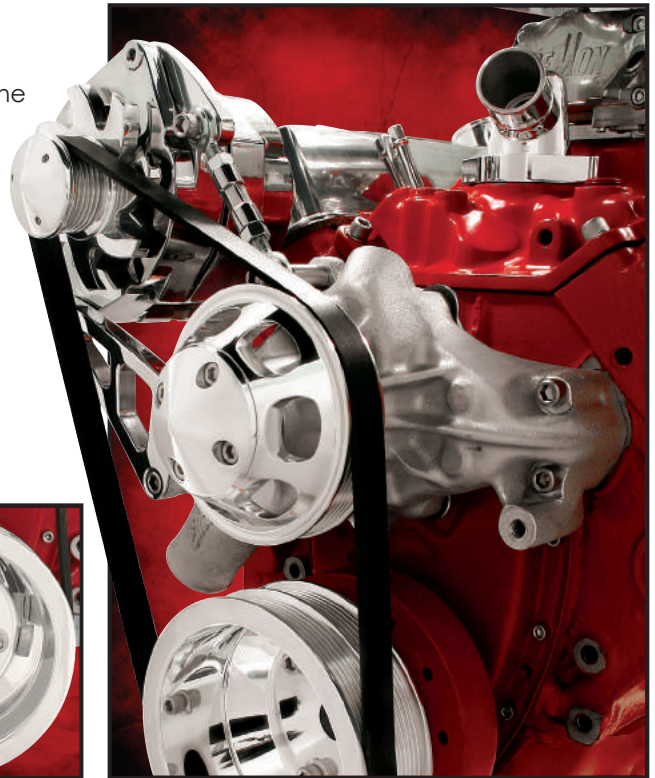

### KIT INCLUDES...

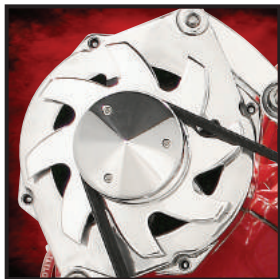

1PC. ALTERNATOR PULLEY  
W/ FAN & NOSE CONE



WATER PUMP PULLEY  
W/ NOSE CONE



CRANKSHAFT PULLEY

Brackets Available On Pages 46-47

### SERPENTINE POWER STEERING PULLEY FOR SAGINAW STYLE PUMP

#### Designed for use with:

- Long water pump
- 6-rib serpentine belt
- Billet Specialties power steering brackets (pages 46-47)

#FM1030PC 1/8" Keyway Pump Shaft (up to '75)  
#FM1035PC Press-on Pump Shaft ('75 & up)

**Pulley Diameter: 5.875"**



### WHY BUY A BILLET PULLEY?

The benefit of a billet aluminum pulley over a cast pulley is equal density. With a cast pulley, the aluminum is poured into a mold and then allowed to cool. This process can create variations in density throughout the pulley. Dense areas are heavier than the more porous areas causing the pulley to vibrate at high RPM. Our billet pulleys are equally dense throughout; equal weight translates to a true and balanced pulley drive system.

# BILLET PULLEYS

## V-GROOVE

### ALTERNATOR PULLEYS

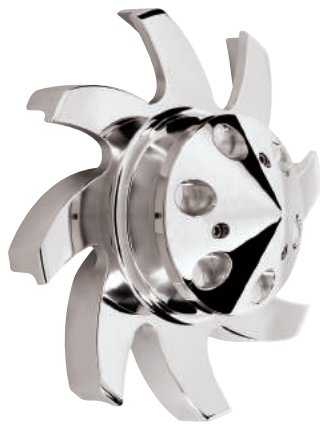

### **1PC. ALTERNATOR PULLEY WITH FAN - 2.5" DIAMETER**

Billet Specialties manufactures the most balanced alternator pulley & fan combo in the industry by machining the unit out of one solid piece of aluminum. This 1-piece pulley and fan combo features a bolt on nose cone to hide the alternator nut and washer, stainless hardware included. Fits most GM, Delco, & Ford alternators.

#85220



### **ALTERNATOR PULLEY - 2.5" DIAMETER**

Machined in the USA from 6061-T6 billet aluminum this Billet Specialties one piece alternator pulley features a bolt on nose cone to hide the alternator nut and washer. Fits most GM, Delco, and Ford alternators.

#85120

### A/C CLUTCH COVERS

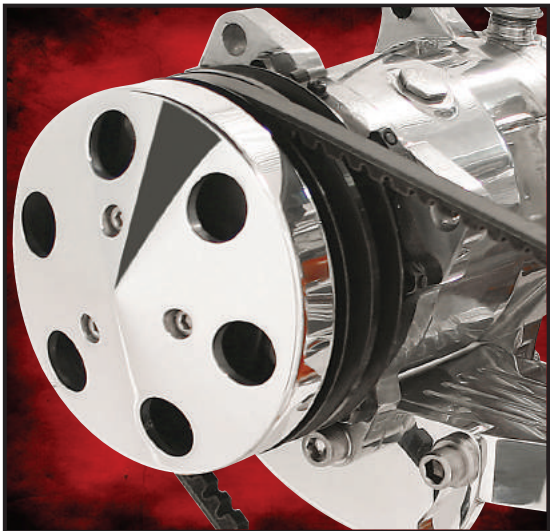

### **SANDEN 508**

Machined from solid billet aluminum, this cover bolts directly to the Sanden 508 clutch with stainless hardware and is polished to a mirror finish.

#87120

### **KNOW THE DIFFERENCE**

Beware of the term "Billet Style". In most cases this is a sign of cast aluminum imitations that offer inferior quality and finish.

# BILLET PULLEYS

## V-GROOVE

### WATER PUMP PULLEYS - 6-7/16" Diameter



SMALL BLOCK CHEVROLET®		BIG BLOCK CHEVROLET®		SMALL/BIG BLOCK CHEVROLET®	
<b>SHORT WATER PUMP</b>		<b>SHORT WATER PUMP</b>		<b>LONG WATER PUMP</b>	
#80120	1-Groove	#82120	1-Groove	#78110	1-Groove
#80220	2-Groove	#82220	2-Groove	#78120	2-Groove
#84120	Nose Cone	#84120	Nose Cone	#84220	Nose Cone
#RP8020	Repl. Bolts	#RP8020	Repl. Bolts		

### CRANKSHAFT PULLEYS - 6-7/16" Diameter



SMALL BLOCK CHEVROLET®		BIG BLOCK CHEVROLET®	
<b>SHORT WATER PUMP</b>		<b>SHORT WATER PUMP</b>	
#81120	1-Groove	#83120	1-Groove
#81220	2-Groove	#83220	2-Groove
#81320	3-Groove	#83320	3-Groove
<b>LONG WATER PUMP</b>		<b>LONG WATER PUMP</b>	
#78210	1-Groove	#79210	1-Groove
#78220	2-Groove	#79220	2-Groove
#78230	3-Groove	#79230	3-Groove

### WHY BUY A BILLET PULLEY?

The benefit of a billet aluminum pulley over a cast pulley is equal density. With a cast pulley, the aluminum is poured into a mold and then allowed to cool. This process can create variations in density throughout the pulley. Dense areas are heavier than the more porous areas causing the pulley to vibrate at high RPM. Our billet pulleys are equally dense throughout; equal weight translates to a true and balanced pulley drive system.

# POWER STEERING PULLEYS & COMPONENTS

## POWER STEERING PULLEYS - 6" Diameter



### V-GROOVE POWER STEERING PULLEY 1966 - 1974 POWER STEERING PULLEY

Designed for use with:

- Long or short water pump
- '66-'74 Saginaw power steering pump
- Power steering pump with attached reservoir
- 1/8" keyway pump shaft

#86120 1-groove  
#86220 2-groove

### V-GROOVE POWER STEERING PULLEY 1975 & UP POWER STEERING PUMP

Designed for use with:

- Long water pump
- '75 & up Saginaw power steering pump
- Power steering pump with attached reservoir
- Press-on pump shaft

#86420 1-groove  
#86520 2-groove

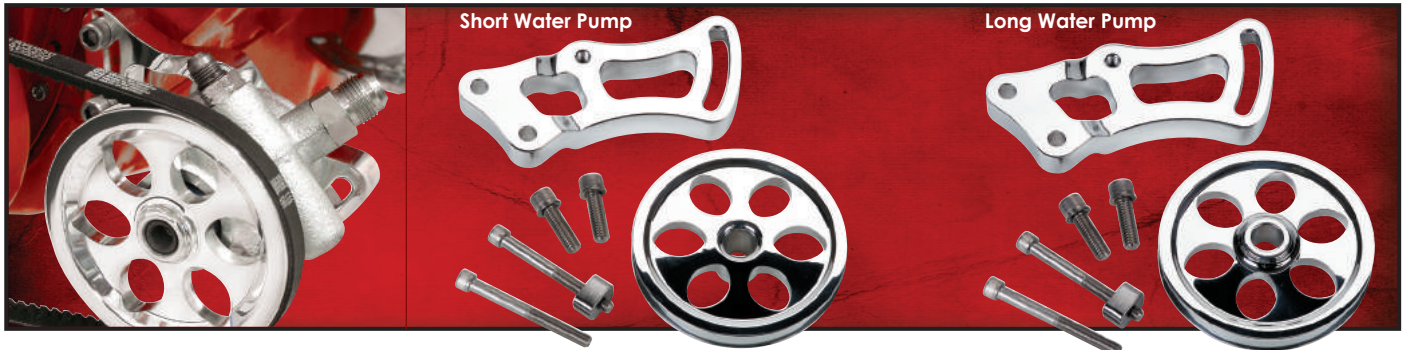

### POWER STEERING BRACKET & PULLEY KIT

Engineered to work with GM type II remote power steering pumps. Billet Specialties power steering bracket and pulley is precision machined from 6061-T6 billet aluminum and mounts low on the driver's side of the motor.

**\*Requires a 3-Groove Crank Pulley\***

Dimensions:

From center of crank pulley to outside of power steering pulley:

- Small Block Chevy™ - 11.00"
- Big Block Chevy™ - 10.75"
- Pulley Diameter: 4.75"

### SMALL BLOCK CHEVROLET®

#12120 Short Water Pump

#12220 Long Water Pump

### BIG BLOCK CHEVROLET®

#12320 Short Water Pump

**\*Check for clearance before ordering\***

## POWER STEERING PUMPS

Product Features:

- Flow rate: 3.5GPM @ 1200PSI
- Cad plated AN fittings pre-installed
- New pump (not remanufactured)

#12020 Natural  
#12025 Polished

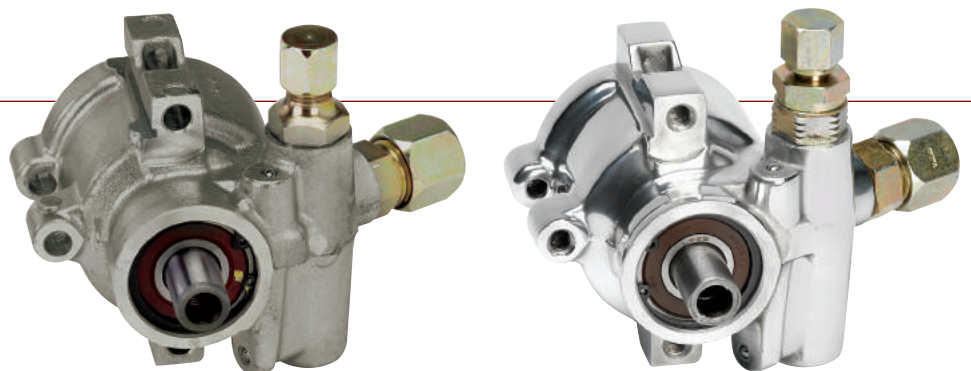

# POWER STEERING COMPONENTS

## REMOTE POWER STEERING RESERVOIR

In your choice of Smooth or Ribbed styles, our remote power steering reservoirs are much more than empty cans. The double O-ring sealed breathable cap relieves positive and negative pressure while keeping your engine compartment clean. Forget foaming and fluid turbulence with our innovative internal return tube. Includes male AN fittings on the bottom of the reservoir.

Our exclusive bracket design clamps to the reservoir with an internal lock. The mounting hardware is completely hidden!

### Note:

- Bracket must be installed at center of reservoir as shown
- Not for use with Hydroboost systems

#77910	Smooth Reservoir w/ Bracket Polished
#77920	Ribbed Reservoir w/ Bracket Polished
#BLK77910	Smooth Reservoir w/ Bracket Black
#RP7701	-8AN Power Steering Supply Fitting

## TECH TIP

For optimal performance always mount the remote power steering reservoir higher than the power steering pump.

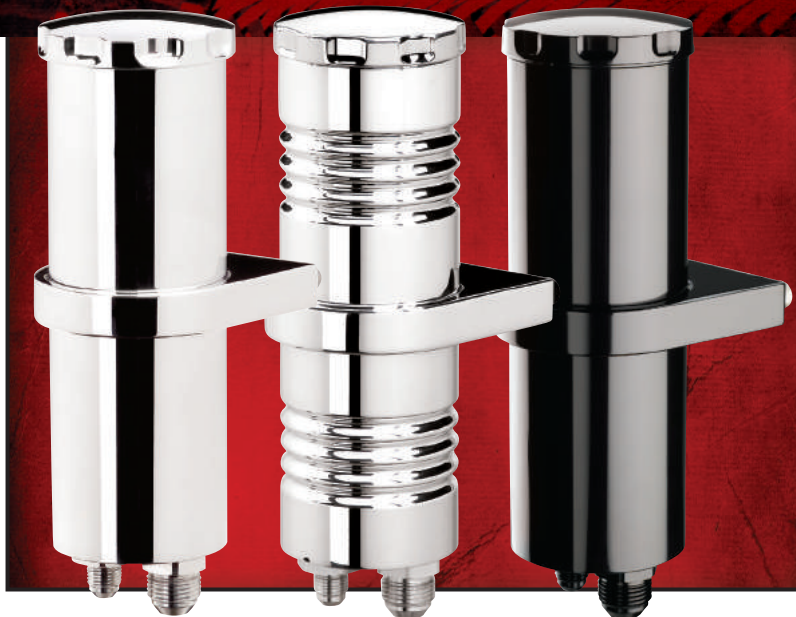

## POWER STEERING HOSE KIT FOR REMOTE RESERVOIR

We take the guesswork out of power steering hoses to save you time and money. Each kit is supplied with enough adapters to cover most popular GM boxes and Ford type racks. Quality fittings and hose from Russell Performance are used exclusively to ensure reliability. Included -6 & -10 fittings match our remote power steering reservoirs and the GM Type II pumps used in Tru Trac & V-Trac pulley systems.

### Applications:

- '65-'78 GM 800 steering gear box (Metric & SAE)
- '74-'77 Ford Mustang II rack & pinion
- CPP GM 500 steering gear box
- GM rack & pinion
- Flaming River rack & pinion
- Dodge Omni rack & pinion

#77900 Hose Kit for Remote Reservoir

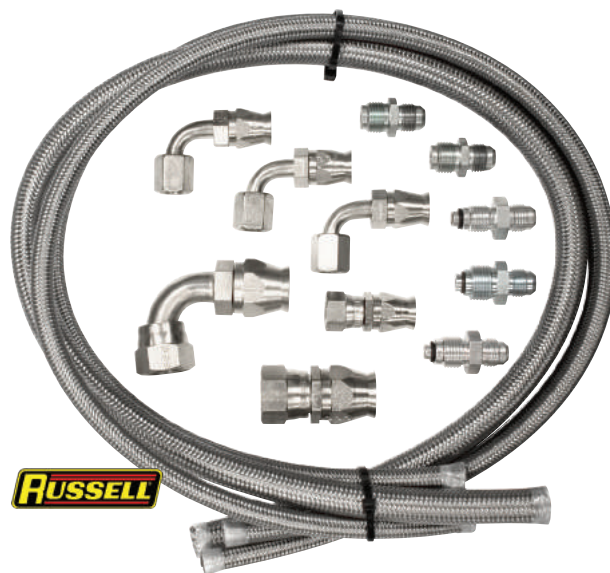

## QUALITY INSIDE AND OUT!

- Internally baffled and O-ring sealed cap to prevent splash over
- Vented cap eliminates positive & negative pressure which leads to foaming
- Innovative internal return tube greatly reduces fluid turbulence & foaming
- Extra capacity of up to 15oz. of fluid in a compact design
- Sleek mounting bracket with internal key lock design hides all hardware
- -6 & -10 AN male AN fittings are included and pre-installed
- 100% billet aluminum construction - polished to a mirror finish
- Overall dimensions: 2-7/8" O.D. x 8-3/4"H (Cap: 3" O.D.)



Matching Overflow Tanks, see page 79 for details!



### **PUMP MOUNT RESERVOIR**

Billet Specialties pump mount billet reservoir is a machining marvel with innovative features such as threaded double O-ring reservoir and hose attachments providing secure leak free service. Precision machined internal baffling eliminates foaming and is topped off with a vented notch grip cap to match our other accessories.

#### **Product Features:**

- Precision 3D Machined
- 6061-T6 billet aluminum
- Vented fill cap with dipstick
- High fluid capacity

#77930 Polished  
#BLK77930 Black Anodized

\* Only works with SB-BBC Tru Trac, V-Trac & FM Serpentine Conversion Kits \*



### **POWER STEERING HOSE KIT FOR PUMP MOUNT RESERVOIR**

We take the guesswork out of power steering hoses to save you time and money. Each kit is supplied with enough adapters to cover most popular GM boxes and Ford type racks. Quality fittings and hose from Russell Performance are used exclusively to ensure reliability. Included -6 fittings match our pump mount power steering reservoirs and the GM Type II pumps used in Tru Trac & V-Trac pulley systems.

#### **Features:**

- 2 - 3ft sections - 6 Powerflex High Pressure Hose
- 5 - 6 AN Endura Hose Ends
- Adapters to fit most Rack & Steering Boxes
- Comprehensive Instructions

#77905 Hose Kit for Pump Mount Reservoir

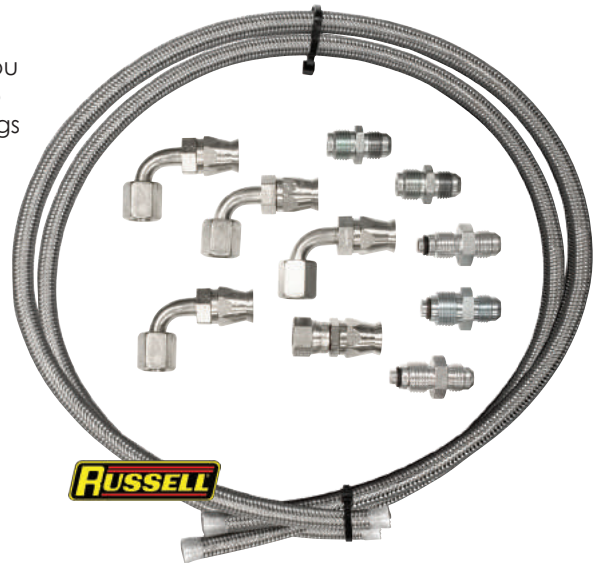

### **POWER STEERING ADAPTER KIT**

#### **Applications:**

- '77-'78 Mustang II rack & pinion
- Up to '88 T-Bird rack & pinion
- Maval Mfg. rack & pinion
- Saginaw 600 steering gear box

#77901



### **RESERVOIR TIGHT FIT KIT**

Kit includes -6 & -10 90° AN fittings for use with our billet remote reservoirs when available space does not allow for the use of straight fittings.

#77902



### **2GPM FLOW CONTROL VALVE**

Reduce the flow of GM type II power steering pumps from 3.5 GPM to 2 GPM which is recommended for Mustang II rack & pinion steering.

#RP1300

# STREAMLINE AIR CLEANERS

## OVAL STREAMLINE - BLACK

Billet Specialties Streamline air cleaners offer a fresh new look for Hot Rod Custom car air cleaners. Precision Machined Billet aluminum tops capped off with a 3D machined wing nut and single raised rib complement any exterior trim cues.

### Available finishes include:

- Satin black powder coat with a polished trim strip and wing nut.
- Ready to Finish bead blasted surface ready to be powder coated or primed and painted with a polished trim strip and wing nut.

### Product Features:

- Includes integrated wing nut easily replaceable filter element
- Stainless steel mounting hardware
- Fits Standard 4-Barrel Carburetors (Not for use with Dominator carburetors)

#15324 Small Oval

#15424 Large Oval



**WE PREPPED IT!, YOU PAINT IT!**



## OVAL STREAMLINE - READY TO FINISH

#15324RTF Small Oval

#15424RTF Large Oval

## 14" ROUND STREAMLINE

#15824RTF Ready to Finish

#15824 Black

### Dimensions:

Small Oval: 11-7/8"L x 8-3/8"W x 3-3/4"H

Large Oval: 15"L x 8-1/2"W x 3-3/4"H

Round: 14" Overall Diameter / 3-3/4" Tall

### DEMON CARB?

For proper installation of a Billet Specialties air cleaner you'll need a Demon Carb Stud Kit #RP1516

# RIBBED AIR CLEANERS

## ROUND 14" PROFILE

Billet Specialties Profile accessories are something special. Each product is a progression of styling and machining precision. Our Profile 14" air cleaner is no exception, featuring a 3D machined top with billet perimeter posts retaining a K&N filter for performance - all on top of a fully machined carb base and clamp. Polished to perfection the 14" Profile air cleaner will be the centerpiece of your engine compartment.

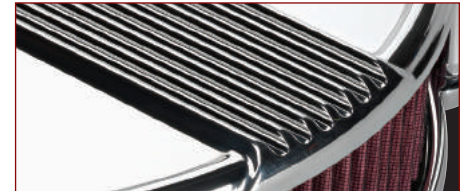

#P15840 14" Round



K&N Lifetime Filter  
Included!

## DUAL QUAD

By using adjustable mounting plates, dual quad air cleaners will fit carburetors with a minimum spacing of 6-3/8" to a maximum spacing of 8-13/16" measured from center to center of each carb. Some applications may require trimming of mounting plates.

#15650 Dual Quad

Dual Quad Adjustable Base. Fits carburetors with a minimum spacing of 6-3/8" to a maximum spacing of 8-13/16" measured from center to center of each carb.



K&N Lifetime Filter  
Included!

## OVAL RIBBED

Traditional Hot Rod Style is reflected in our Ribbed Air Cleaners. Machined raised ribs rise from the mirror polished surface via thousands of lines of programming code, each radius matches other ribbed accessories for consistency. Truly in a class by themselves, Billet Specialties air cleaners are the best quality air cleaner you can buy.

### Product Features:

- High quality, industry leading mirror finish polish
- Easily replaceable filter element
- Stainless steel mounting hardware
- Fits standard 4-barrel carburetors (Not for use with Dominator carburetors)

#15630 Small Oval

#15640 Large Oval

### Dimensions:

Small Oval: 11-7/8"L x 8-3/8"W x 3"H

Large Oval: 15"L x 8-1/2"W x 3"H

Dual Quad: 17-1/2"L x 9-3/8"W x 3-1/4"H

Round: 14.5" Overall Diameter / 3-1/4" Tall



# PLAIN AIR CLEANERS

When simple says more, our plain air cleaners say it the best with mirror finished perfection. Plainly put, you will not find a better quality air cleaner anywhere. Precision machined from 6061-T6 aluminum and supplied with stainless hardware and common easy to replace filter elements make Billet Specialties air cleaners stand out from the crowd.

**Product Features:**

- High quality, industry leading mirror finish polish
- Easily replaceable filter element
- Stainless steel mounting hardware
- Fits standard 4-barrel carburetors  
(Not for use with Dominator carburetors)

**Dimensions:**

Small Oval: 11-7/8"L x 8-3/8"W x 3"H  
 Large Oval: 15"L x 8-1/2"W x 3"H  
 Dual Quad: 17-1/2"L x 9-3/8"W x 3-1/4"H  
 Round: Overall Height 3"  
 Triangle: 14-7/8"L x 13-1/2"W x 3-1/8"H

- #15329 Small Oval
- #15429 Large Oval

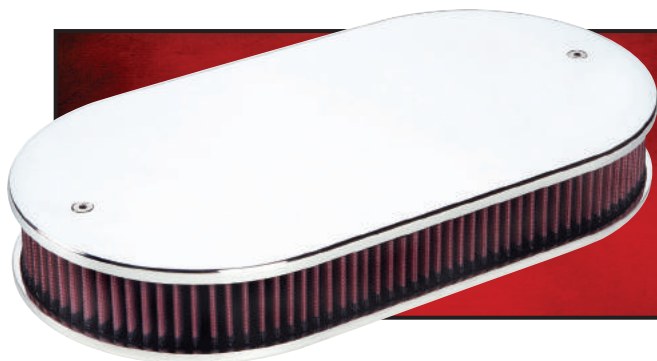

#15529 Dual Quad Plain

**K&N**  
 THE WORLD'S BEST AIR FILTER  
 K&N Lifetime Filter  
 Included!

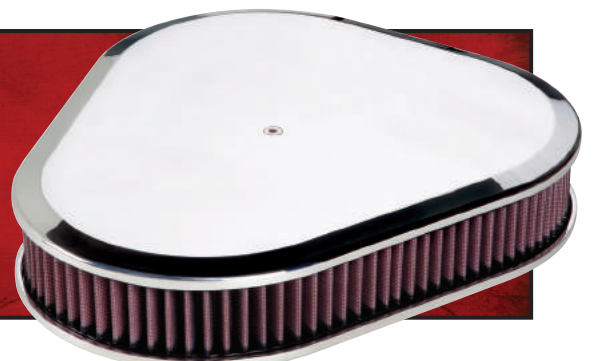

#15729 Triangle Plain



6-3/8" Round Plain  
 #15129

**K&N**  
 THE WORLD'S BEST AIR FILTER  
 K&N Lifetime Filter  
 Included!



10" Round Plain  
 #15229



14" Round Plain  
 #15829  
 Includes 1" steel drop base

# BALL MILLED AIR CLEANERS



Classic Billet Specialties Ball Milled air cleaners will stand the test of time and have set today's standards of design. Precision machined from 6061-T6 aluminum then polished to a mirror finish, Billet Specialties Ball Milled air cleaners feature stainless hardware and standard size air filters for ease of service and long life. Stand out in the crowd with a Billet Specialties Ball Milled air cleaner.

### Product Features:

- High quality, industry leading mirror finish polish
- Easily replaceable filter element
- Stainless steel mounting hardware
- Fits standard 4-barrel carburetors  
(Not for use with Dominator carburetors)

#15320 Small Oval

#15420 Large Oval



**K&N**  
THE WORLD'S BEST AIR FILTER  
K&N Lifetime Filter  
Included!



#15720 Triangle Ball Milled

#15520 Dual Quad Ball Milled



14" Round Ball Milled  
#15820

Includes 1" steel drop  
base



10" Round Ball Milled  
#15220



6-3/8" Round Ball Milled  
#15120

**K&N**  
THE WORLD'S BEST AIR FILTER  
K&N Lifetime Filter  
Included!

# 14" ROUND AIR CLEANERS

Billet Specialties' Classic and Vintage air cleaners offer a modern alternative from the decade's old standard of stamped steel air cleaners. Stand out from the crowd with three versions to choose from, Vintage polished or black powder coated for the 50-60's style and the Classic for your muscle car – high horsepower fix. Precision machined top features a unique billet wingnut on top of a quality element and 1" steel drop base for hood clearance.

## Product Features:

- 14" Round diameter
- 3" Overall height
- 1" Drop base
- Stainless hardware
- Fits standard 4-barrel carburetors
- Paper element

#15837

#BLK15830

#15830

Polished Classic

Black Vintage

Polished Vintage



Polished Classic



Black Vintage



Polished Vintage



MACHINED BILLET WINGNUT

# CROSS FLAG AIR CLEANERS



Classic 60's cross flag styling is machined right into the billet aluminum top for a look that cast aluminum air cleaners cannot match. Billet Specialties unmistakable mirror finish guarantees the attention your engine compartment deserves. Includes stainless hardware for long life and easy to find common size elements for easy replacement.

#### Product Features:

- High quality, industry leading mirror finish polish
- Stainless steel mounting hardware
- Fits standard 4-barrel carburetors (Not for use with Dominator carburetors)

#### Dimensions:

Small Oval: 11-7/8"L x 8-3/8"W x 3"H  
Large Oval: 15"L x 8-1/2"W x 3"H

#15327 Small Oval

#15427 Large Oval

## REPLACEMENT ELEMENT GUIDE

### Oval Air Cleaner Elements

Available at most automotive stores

	Brand	Dimensions (in)	Part #
<b>SMALL OVAL</b>			
Stock	Group 7	11.5 x 8.125 x 2	VA-3138
Aftermarket	K&N	11.5 x 8.125 x 2	E-3505
<b>LARGE OVAL</b>			
Stock	Group 7	14.625 x 7.75 x 2	VA-3193
Aftermarket	K&N	14.625 x 7.75 x 2	E-3515

### Dual Quad/Triangle Air Cleaner Elements

Available at most automotive stores

	Brand	Dimensions (in)	Part #
<b>DUAL QUAD/TRIANGLE</b>			
Stock	K&N	14 OD x 12 ID x 2.31	E-3740

## REPLACEMENT PARTS

RP1500	Air Cleaner Stud Kit
RP1516	5/16" Demon Carb Stud Kit
RP1508	14" Round Air Cleaner - Flat Base

### Round Air Cleaner Elements

Available at most automotive stores

	Brand	Dimensions (in)	Part #
<b>ROUND 6-3/8"</b>			
Stock	Group 7	6.125 OD x 5.125 ID x 2	E-3330
<b>ROUND 10"</b>			
Stock	Purolator	9.75 OD x 8 ID x 2.25	A30045
Aftermarket	K&N	9.75 OD x 7.875 ID x 2	E-2740
<b>ROUND 14"</b>			
Stock	Purolator	14 OD x 11.675 ID x 3	A60074
Aftermarket	K&N	14 OD x 12 ID x 2.3125	E-3740



2.5" Tall Spacer Ring for Dual Quad & Triangle Air Cleaners

15500-905

# BILLET VALVE COVERS

## PROFILE COLLECTION

Meticulously crafted from solid blocks of 6061-T6 billet aluminum, Billet Specialties Profile Valve Covers shatter the mold. Innovative style and precision machining combine to create the ultimate valve covers. Separate your motor from the rest with a pair, and then get ready for some attention! All Valve Covers sold in pairs.

### Product Features:

- 6061-T6 billet aluminum construction
- Mirror polished finish matches other Billet Specialties engine accessories
- Polished ARP 12-point stainless fastening hardware included
- Billet aluminum screw-in oil fill cap included

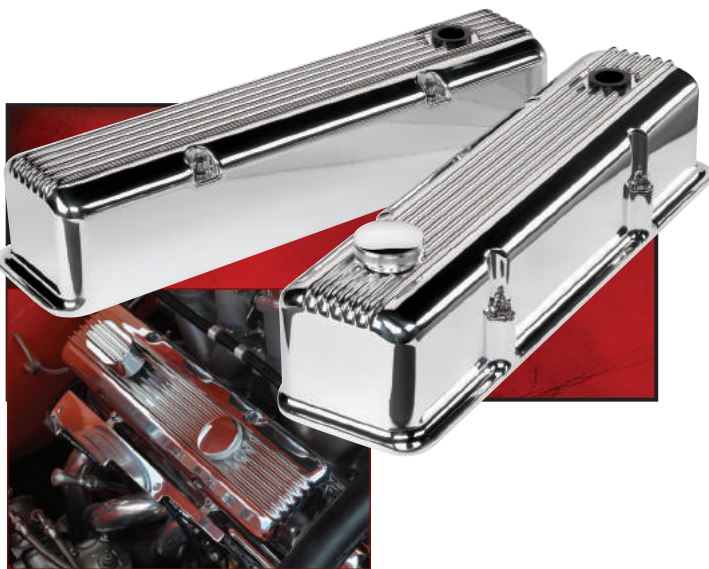

### SMALL BLOCK CHEVROLET®

#P95250

Overall Height: 4.15"

### LS CHEVROLET®

#P95450

Ribbed

#P95459

Plain



\* Valve Covers do not have a provision for coil mounts





## LS MODULAR VALVE COVERS

True innovation with features like the coil packs and oil fill cap hidden under the ribbed and vented top cover, ARP 12 pt. stainless hardware and two finish options. Our LS modular valve covers clean up your engine and add aggressive styling - get a pair today.

\*Go to [billetspecialties.com](http://billetspecialties.com) for complete tech specs regarding these LS valve covers.

### Product Features:

- 6061-T6 billet aluminum construction
- Hidden billet aluminum screw-in oil fill cap included
- Polished ARP 12-point stainless fastening hardware included
- Mirror polished or Black Anodized finishes match other Billet Specialties engine accessories



### LS1 CHEVROLET®

#P95460 LS1 Coil Ribbed Polished

#P95465 LS1 Coil Ribbed Black

**Important-Requires OEM Coil**

LS1 Coils GM #12558948

### LS3 CHEVROLET®

#P95470 LS3 Coil Ribbed Polished

#P95475 LS3 Coil Ribbed Black

**Important-Requires OEM Coil**

LS3 Coils GM #12611424

\* Not for use with OEM Corvette accessory drives

### HIDES THE FACTORY LS COILS & WIRING

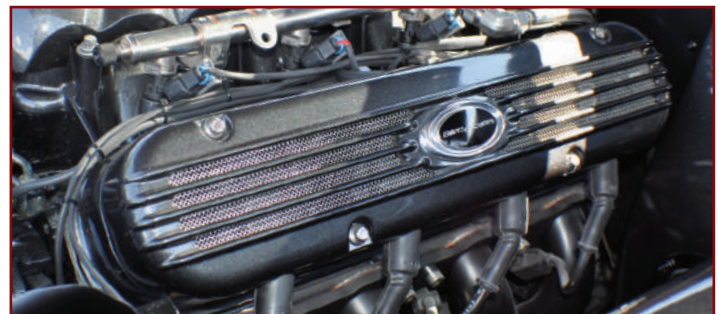

# VALVE COVERS

## SMALL BLOCK CHEVROLET®

Our CNC milled aluminum valve covers are guaranteed to draw attention to your engine compartment. Available in short and tall heights with a 1-1/4" diameter breather hole positioned between the rockers to reduce oil splash. Valve covers are produced from a high-grade aluminum that is polished to Billet Specialties standards and each design is CNC machined in the USA. Use tall style valve covers if using roller rockers and stud girdles. All Valve Covers sold in pairs.

### Product Features:

- Includes metal baffles
- Includes grommets
- Accepts 1-1/4" breathers (pgs 72-73)
- Short valve covers: 2-3/4"H
- Tall valve covers: 3-3/4"H



**BLACK POWDER COAT**

#BLK95221 Bowtie Black Tall

#BLK95223 Chevrolet Black Tall



#95121 Bowtie Short  
#95221 Bowtie Tall

#95123 Chevrolet Short  
#95223 Chevrolet Tall



#95122 Chevy Power Short  
#95222 Chevy Power Tall

#95129 Plain Short  
#95229 Plain Tall

### REPLACEMENT PARTS

For replacement parts see page 69

## STREAMLINE VALVE COVERS

Billet Specialties Streamline Valve Covers offer a fresh new look in valve cover choices. The precision machined billet aluminum trim strip complements our Streamline Air Cleaners. Available in two finishes; Satin black powder coat with a polished billet aluminum trim strip or Ready to Finish that has a bead blasted surface ready to be powder coated or primed and painted with a polished trim strip. Includes stainless hardware and baffles.

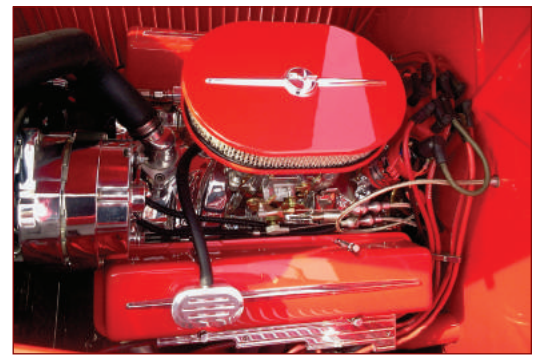

#95224 Streamline Black Tall

#95224RTF Streamline RTF Tall



#95120 Ball Milled Short  
#95220 Ball Milled Tall

#95127 Cross Flags Short  
#95227 Cross Flags Tall



**Ribbed**  
Machined "fins" sit above the mirror finished surface of these valve covers.

#95620 Ribbed Tall

**TECH TIP**  
For the best seal, Billet Specialties recommends the use of a cork gasket with all of the valve covers we sell.

# VALVE COVERS

## BIG BLOCK CHEVROLET®

Our CNC milled aluminum valve covers are guaranteed to draw attention to your engine compartment. Available in short and tall heights with a 1-1/4" diameter breather hole positioned between the rockers to reduce oil splash. Valve covers are produced from a high-grade aluminum that is polished to Billet Specialties standards and each design is CNC machined in the USA. Use tall style valve covers if using roller rockers and stud girdles. All Valve Covers sold in pairs.

### Product Features:

- Includes metal baffles
- Includes grommets
- Accepts 1-1/4" breathers (pgs 72-73)
- Short valve covers: 2-3/4"H
- Tall valve covers: 3-3/4"H



**BLACK POWDER COAT**

#BLK96121 Bowtie Black Tall

#BLK96123 Chevrolet Black Tall



#96021 Bowtie Short  
#96121 Bowtie Tall

#96023 Chevrolet Short  
#96123 Chevrolet Tall



#96022 Chevy Power Short  
#96122 Chevy Power Tall

#96029 Plain Short  
#96129 Plain Tall

# VALVE COVERS & HOLD DOWNS

## STREAMLINE VALVE COVERS

Billet Specialties Streamline Valve Covers offer a fresh new look in valve cover choices. The precision machined billet aluminum trim strip complements our Streamline Air Cleaners. Available in two finishes; Satin black powder coat with a polished billet aluminum trim strip or Ready to Finish that has a bead blasted surface ready to be powder coated or primed and painted with a polished trim strip. Includes stainless hardware and baffles.



#96124 Streamline Black Tall

#96124RTF Streamline RTF Tall



#96020 Ball Milled Short  
#96120 Ball Milled Tall

#96027 Cross Flags Short  
#96127 Cross Flags Tall

## VALVE COVER HOLD DOWNS

Each hold down is 2-7/8" tall with 1/4-20 threaded stud and can only be used on the exhaust side of tall big block valve covers.

- #95011 Acorn
- #95012 Ribbed
- #95013 Hex

Longs studs are required when using our billet wire looms.

#RP9510 Long Stud Kit



Hex Acorn Ribbed



## REPLACEMENT PARTS

- #95002 Grommet (1-1/4" Valve Cover Hole)
- #RP956033 Baffles - Small Block Tall
- #RP956034 Baffles - SB/Short - BB/Tall
- #RP956035 Baffles - Big Block Short

## TECH TIP

Tall style big block valve covers are recommended for use with roller rockers.

# VALVE COVERS

## CENTER BOLT CHEVROLET®

Our CNC milled aluminum valve covers are guaranteed to draw attention to your engine compartment. Available in short and tall heights with a 1-1/4" diameter breather hole positioned between the rockers to reduce oil splash. Valve covers are produced from a high-grade aluminum that is polished to Billet Specialties standards and each design is CNC machined in the USA. All Valve Covers sold in pairs.

### Product Features:

- Includes stainless bolts
- Includes grommets
- Accepts 1-1/4" breathers (pages 72-73)
- Short valve covers: 2-3/4"H
- Tall valve covers: 3-3/4"H



Tall Style



#95829	Plain	Short
#95729	Plain	Tall



#95820	Ball Milled	Short
#95720	Ball Milled	Tall



Tall Style



#95827	Cross Flags	Short
#95727	Cross Flags	Tall



Tall Style

### REPLACEMENT PARTS

#95002	Grommet (1-1/4" Valve Cover Hole)
#95800-802	Center Bolt Screw Kit - 8pc/set - Short
#95700-802	Center Bolt Screw Kit - 8pc/set - Tall
#RP956034	Baffles - Center Bolt
#RP9570	Gasket - Centerbolt Valve Cover

### TECH TIP

Not for use with stud girdles. Center bolt valve covers should be run with one breather and one PCV valve or PCV breather for proper air circulation.

# VALVE COVERS

## SMALL BLOCK FORD

### STREAMLINE VALVE COVERS SMALL BLOCK FORD

Billet Specialties Streamline Valve Covers offer a fresh new look in valve cover choices. The precision machined billet aluminum trim strip complements our Streamline Air Cleaners. Available in two finishes; Satin black powder coat with a polished billet aluminum trim strip or Ready to Finish that has a bead blasted surface ready to be powder coated or primed and painted with a polished trim strip. Includes stainless hardware and baffles.



#95324 Streamline Black Tall

#95324RTF Streamline RTF Tall

### PRECISION CAST SMALL BLOCK FORD

#### Product Features:

- Polished finish
- Tall style design
- 1-1/4" breather hole  
(see pages 72-73 for breathers)

#### Dimensions:

- Interior: 4"W x 3.5625"T
- Overall Height: 3.875"

#95320 Tall



# OIL FILL CAPS

Precision machined from 6061-T6 billet aluminum. Billet Specialties oil fill caps fit a variety of applications. Weld in bung is 1-5/8" diameter and can be used by welding bung to valve covers, aluminum tanks, etc.

#### Product Features:

- Knurled edge for positive grip
- Buna N® O-ring for no-leak operation



Screw-On  
#23320



Push-On (1-1/4" Hole)  
#23120



Aluminum Weld-In  
#24110



Twist-On  
#23220

# BREATHERS

Billet Specialties breathers are precision machined in the USA from 6061-T6 billet aluminum and feature a unique 2 pc. design with a positive O-ring seal. They are easily maintained with a washable filter element. The PCV breather features a common replaceable PCV valve with a barbed fitting for 3/8" hose. Available for 1" or 1-1/4" diameter valve cover holes.

## RETRO BREATHERS

Time for a fresh new look in aftermarket valve cover breathers. Retro Breathers feature classic styling and a two piece design for easy maintenance.



Retro Chevrolet® Script  
**#20923 Breather Polished**  
**#21923 PCV Breather Polished**

Retro Chevrolet® Script  
**#BLK20923 Breather Black**  
**#BLK21923 PCV Breather Black**



Retro Plain  
**#20939 Breather Polished**  
**#21939 PCV Breather Polished**

Retro Plain Black  
**#BLK20939 Breather Black**  
**#BLK21939 PCV Breather Black**

## TECH TIP

Valve covers should be run with one breather and one PCV valve or PCV breather for proper air circulation.

## BILLET PCV VALVE

Engineered to be used with Billet Specialties valve covers and supplied with a grommet for 1-1/4" VC holes. Uses a replaceable PCV valve found at any auto parts store. Will fit O.E. valve covers by using the factory grommet (not supplied).



**#22120 PCV Valve Polished**

## REPLACEMENT PARTS

- #95001 Grommet for #22120**
- #95002 Grommet (1-1/4" Valve Cover Hole)**
- #95003 Grommet w/ baffle (1-1/4" Valve Cover Hole)**
- #RP2010 Breather Filter - Round**
- #RP2011 Breather Filter - Oval**



Breathers feature a 2 pc. design with a positive O-ring seal and washable filter element.



**CROSS FLAGS**

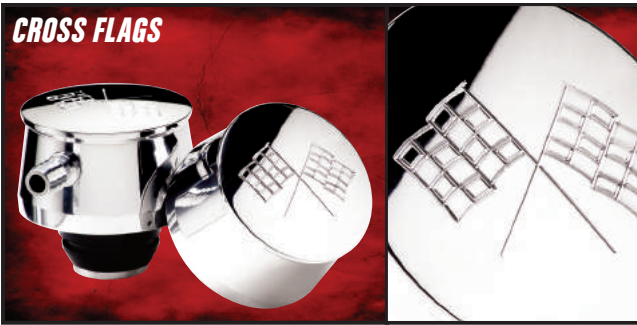

- #20720 1-1/4" VC Hole
- #21720 1-1/4" - PCV - VC Hole

**BOWTIE**

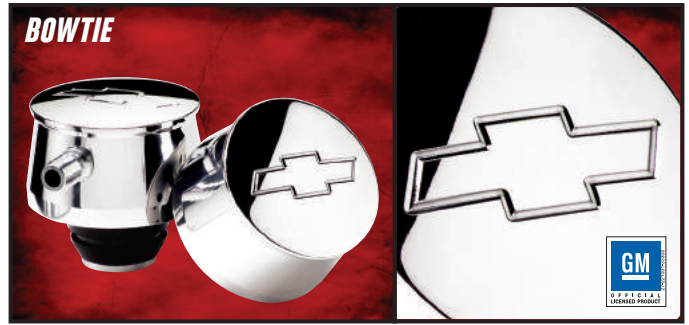

- #20220 1-1/4" VC Hole
- #21220 1-1/4" - PCV - VC Hole

**PLAIN**

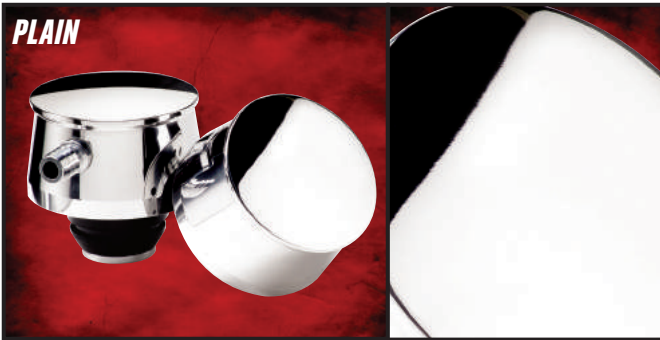

- #20120 1-1/4" VC Hole
- #20125 1" VC Hole
- #21120 1-1/4" - PCV - VC Hole
- #21125 1" - PCV - VC Hole

**ROUND BALL MILLED**



- #20820 1-1/4" VC Hole
- #20825 1" VC Hole
- #21820 1-1/4" - PCV - VC Hole
- #21825 1" - PCV - VC Hole

**BLACK POWDER COAT**



- #BLK20120 1-1/4" VC Hole
- #BLK21120 1-1/4" - PCV VC Hole

**OVAL BALL MILLED**



- #20920 1-1/4" VC Hole
- #21920 1-1/4" - PCV - VC Hole

**OVAL PLAIN**



- #20929 1-1/4" VC Hole
- #21929 1-1/4" - PCV - VC Hole

**OVAL RIBBED**

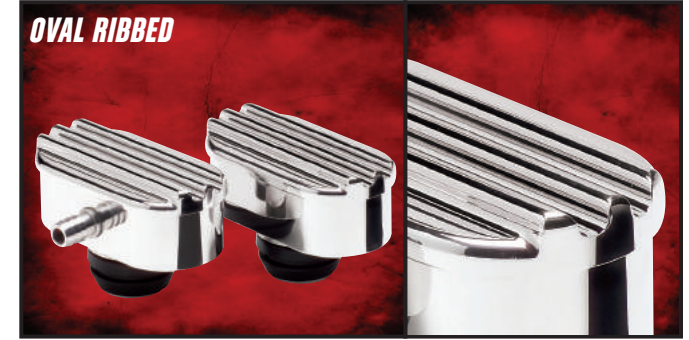

- #20950 1-1/4" VC Hole
- #21950 1-1/4" - PCV - VC Hole

# IGNITION WIRE ORGANIZATION

## UNIVERSAL WIRE LOOMS

Our unique two-piece design fits all big block and small block Chevrolet® and Ford engines. The wire looms mount to the base of the valve cover with adjustable tabs. Sold in Pairs.

### Product Features:

- Fits up to 9mm wires
- Precision machined from 6061-T6 billet aluminum
- Industry leading mirror finish polish
- Stainless steel hardware

Dimensions: 14-3/4" L X 2-1/4" W

## REPLACEMENT PARTS

#RP6900 Wire Loom Screw Kit W/ Wrench



#69520 Ball Milled



#69523 Bowtie

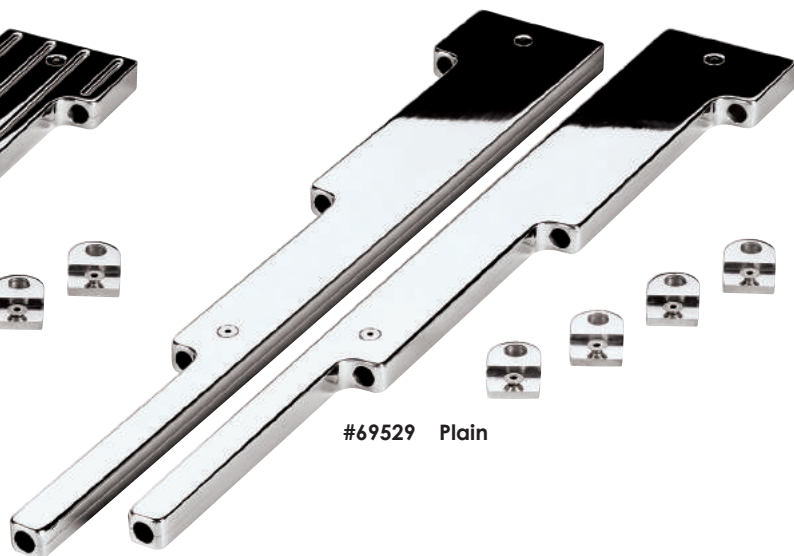

#69529 Plain



## LATE MODEL BRACKET KIT

Brackets attach to cylinder heads between exhaust ports. Providing a mounting location for wire looms.

\* Some headers may require modification to access mount holes.

#69600 Wire Loom Bracket Kit



**BILLET PLUG WIRE SEPARATORS - FOR 8.5 MM WIRES**

Billet Specialties wire separators offer a clean, efficient solution to the ignition wire dilemma by routing the wires in a simple straight-forward fashion. Utilizing stainless fasteners and 6061-T6 aluminum construction Billet Specialties wire separators will make your motor stand out while keeping the wires safely off the hot exhaust. Your specific needs can be custom tailored for your type of motor and routing. Easy snap-in wire retention makes service and installation a breeze. Sold in Pairs.



**VALVE COVER MOUNTS**

1-Wire Polished  
#69701

2-Wire Polished  
#69702

3-Wire Polished  
#69703

4-Wire Polished  
#69704

1-Wire Black Anodized  
#69781

2-Wire Black Anodized  
#69782

3-Wire Black Anodized  
#69783

4-Wire Black Anodized  
#69784

**STAINLESS HARDWARE INCLUDED!**



**CYLINDER HEAD MOUNT**

4-Wire Polished  
#69604

4-Wire Black Anodized  
#69684

**FLOATING CLIPS**

2-Wire Polished  
#69602

2-Wire Black Anodized  
#69682

4-Wire Polished  
#69601

4-Wire Black Anodized  
#69681

# ENGINE BLOCK ACCESSORIES

## LS VALLEY COVER

Is that stock valley cover standing out like a sore thumb on your carbureted LS? Billet Specialties' LS Valley Cover has the cure with a precision machined replacement that compliments our other LS products featuring matching ARP quality hardware and ribbed design.

### Features:

- For use with Carbureted applications.
- 2 1/8" NPT ports for use with breather.
- Stainless ARP hardware included.
- Accepts OEM gasket.

### Engineered To Fit:

- LS2, LS3, LS7 & LSX blocks.

\* Will not work with D.O.D Blocks

#95050



\* Accepts OEM breather

## BIG BLOCK CHEVY™ TIMING COVER

Timing is everything - so you might as well do it with style. Billet Specialties billet aluminum timing cover is precision machined from 6061-T6 aluminum and polished to perfection. Engineered to fit 1965-1990 Big Block Chevrolet® Mark IV engines, our 10 bolt timing cover features improved clearance up to .720" to clear most timing sets and includes two billet timing pointers to fit both 7 and 8 inch dampers.

#88420



\* Includes timing pointer



Polished

Black Anodized

## DISTRIBUTOR CLAMP

Precision machined from 6061-T6 billet aluminum. Available polished or black anodized.

### Product Features:

- Unique No-Mar ball seat pivot design
- Positive lock down eliminates slipping
- Works with small & big block Chevrolet® engines
- Stainless hardware included

#65920  
#BLK65920

Polished  
Black Anodized



## VACUUM ADVANCE COVER

Our polished vacuum advance cover fits right over the unit and hides the unsightly vacuum diaphragm. Installs in minutes with a dab of silicone.

Dimensions: 2.75" I.D. x 1.325" L

#88120

## FUEL BLOCK OFF

Available for big and small block Chevrolet®, Ford & Chrysler motors.

### Product Features:

- Machined from 6061-T6 billet aluminum
- Polished finish
- Stainless hardware included



Small Block  
#41120

Also fits the 348/409

Big Block  
#41220



Small Block  
#41820

Big Block  
#41825



Ford

Small Block: 289/302/351W  
Big Block: 429/460  
Ford FE blocks  
#41620

## SMALL BLOCK CHEVY™ DIPSTICK

Billet Specialties dipstick fits directly into the block on small block Chevrolet® motors up to 1979 and replaces the factory driver side dipstick tube for a clean look.

#40120



## BILLET FUEL FILTERS

For carbureted applications only.  
Mounting bracket sold separately.

### Product Features:

- Smooth or Ribbed styles
- 3/8" hose barb or -6AN fitting
- Replaceable Delco Element - #GF471

Dimensions: 4-1/2"L x 1-3/8" diameter

- |           |                   |
|-----------|-------------------|
| #42120    | Smooth Barbed     |
| #42220    | Smooth -6AN       |
| #BLK42220 | Smooth Black -6AN |
| #42320    | Ribbed Barbed     |
| #42420    | Ribbed -6AN       |
| #42520    | Mounting Bracket  |
| #BLK42520 | Black Bracket     |

\* Not for use with fuel injection



Mounting Bracket  
(Sold Separately)

# COOLING COMPONENTS

## RADIATOR CAPS

Mirror polished or black anodized billet top & quality Stant® radiator cap come unassembled to allow for proper positioning of the logo.

7lb radiator caps are intended for use with pre-1966 radiators.



**Bowtie**  
#75320 16lb.  
#76320 7lb.

**V8**  
#75420 16lb.  
#76420 7lb.

**Circle**  
#75220 16lb.

**Notch Grip**  
#75125 16lb.  
#BLK75125 16lb.

**Plain**  
#75120 16lb.  
#76120 7lb.  
#BLK75120 16lb.

## BILLET THERMOSTAT HOUSINGS

Billet Specialties thermostat housings are precision machined from 6061-T6 billet aluminum. Available polished or black anodized.

- Swivels for proper hose angle
- Stainless steel mounting hardware included

### CHEVROLET® SMALL/BIG BLOCK



**Straight-Up**  
#90120  
#BLK90120



**0-Degree**  
#90220  
#BLK90220



**15-Degree**  
#90320  
#BLK90320



**45-Degree**  
#90420  
#BLK90420

\*Not for use with Tuned Port or Ram Jet applications\*

### FORD SMALL BLOCK

289, 302, 351W



**0-Degree**  
#90620  
#BLK90620

### FORD BIG BLOCK



**0-Degree**  
#90720

**15-Degree**  
#90725

### FORD FE



**0-Degree**  
#90730

### CHRYSLER SMALL/BIG BLOCK & HEMI TO 1978



**Straight-Up**  
#90820

**O-RING SEAL  
ELIMINATES GASKETS!**

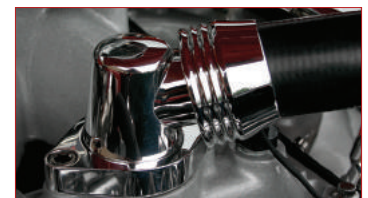

## BILLET OVERFLOW TANKS

Looking for the best overflow tank on the market? Look no further - they're right here! Billet Specialties overflow tanks are machined from 6061-T6 billet aluminum and include two adjustable billet mounting brackets to ensure proper positioning. Choose from either ribbed or smooth designs to match our engine accessories. Tanks are 2" in diameter and available in three lengths measured from bottom of cap to base of tube.

### Product Features:

- Knurled O-ring cap for a no-leak seal
- Stainless hardware included
- Aluminum push-on fittings included
- Industry leading mirror finish polish
- Internal return tube

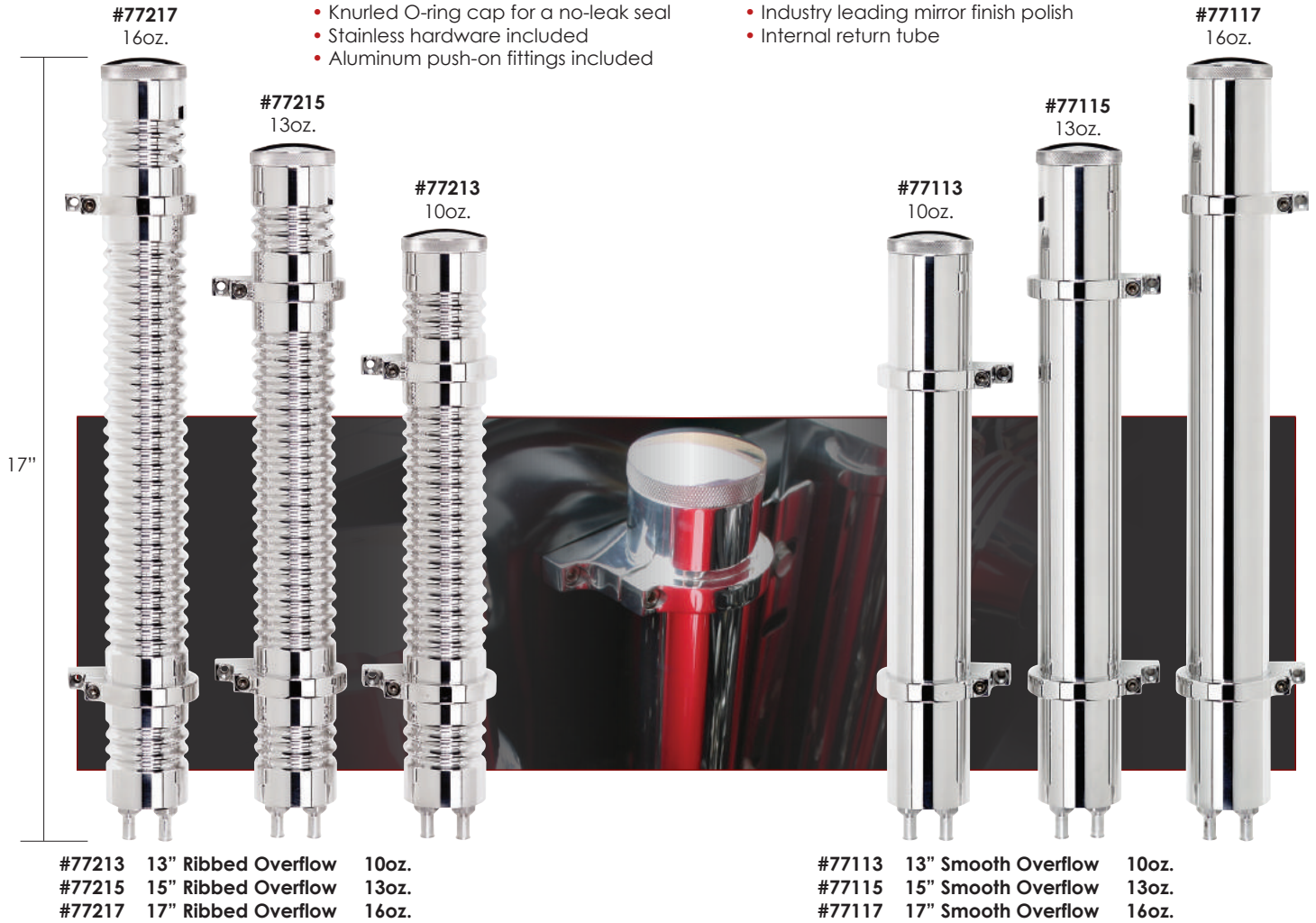

## 8.75" BILLET OVERFLOW TANKS

- 100% billet aluminum construction
- Mirror polished finish or high-gloss black anodized finish
- Fluid capacity: 15oz.

**Dimensions:** 2-7/8" O.D. x 8-3/4"H (Cap: 3" O.D.)

Our exclusive bracket design clamps to the tank with an internal lock. The mounting hardware is completely hidden!

**Note:** Bracket must be installed at center of reservoir as shown.

#77109 Smooth Polished Tank w/ Bracket  
 #BLK77109 Black Anodized Tank w/ Bracket

Matching Power Steering Reservoir, see page 56 for details!



BLACK ANODIZED

# HOSE & LINE MANAGEMENT

## BILLET HEATER & A/C BULKHEADS

Billet Specialties heat and AC bulkheads are engineered to work with 5/8" heater hose and one #6 and one #10 AC line.

- Hose Fittings Not Included
- Push-on for heater side only
- Stainless heater hose applications require a male tube O-ring To AN adapter

### Product Features:

- Precision machined 6061-T6 aluminum
- Industry leading polish finish
- Offset design allows clear access to lines
- Uniform hose routing in a minimum space



AC Bulkhead  
#66720



AC & Heater Combo  
#66920



Heater Bulkhead  
#66820



Heater Bulkhead (Push-On)  
#66825



AC & Heater Combo (Push-On\*)  
#66925  
\* Heater Side Only



AC & Heater In-Line (Push-On\*)  
#66935  
\* Heater Side Only

## POLISHED BILLET HOSE ENDS

Billet Specialties has the answer for unsightly hose clamps and loud anodized colors - polished billet hose ends! Available in popular sizes for rubber and braided hoses from 5/16" to 1-3/4".



Billet Hose Ends – Fuel  
#67025 5/16" Braided  
#67225 3/8" Rubber  
#67325 3/8" Braided



Billet Hose Ends – Heater  
#67425 5/8" Rubber  
#67525 5/8" Braided  
#67625 3/4" Rubber  
#67725 3/4" Braided



Billet Hose Ends – Radiator\*  
#67825 1-1/2" Rubber  
O.D. - 2.00"  
#67925 1-3/4" Rubber  
O.D. - 2.25"



### Product Features:

- CNC machined aluminum
- Mirror polished finish
- Hose clamp included

\* Not for use on water pump outlets



## BILLET HOSE SEPARATORS

Billet Specialties hose separators are precision machined from 6061-T6 billet aluminum and are available in many popular combinations and sizes. Sold individually.

### Product Features:

- Industry leading mirror finish polish
- Stainless bolt



	Hose O.D.		Hose O.D.		Hose O.D.
#68020	.440 x .540	#68320	.625 x .625	#68625	.890 x .969
#68025	.440 x .630	#68325	.625 x .781	#68720	.906 x .906
#68120	.500 x .500	#68420	.734 x .890	#68725	.906 x 1.015
#68125	.540 x .630	#68425	.734 x .969	#68729	.906 x 1.125
#68220	.562 x .562	#68520	.781 x .781	#68820	1.015 x 1.015
#68225	.562 x .625	#68525	.781 x .906		

## TECH TIP

A hose's listed size is always in reference to the inside diameter of that hose. Example, a 5/8" heater hose has an inside diameter (I.D.) of 5/8" while the outside diameter (O.D.) is 29/32" or .906. The O.D. is the dimension needed when purchasing hose separators.

## HOSE SEPARATOR TECHNICAL DATA – Decimal/Fraction = Outside Diameter

BRAIDED AC HOSE DIAMETER			AC HOSE DIAMETER			BRAIDED AN LINE DIAMETER			HEATER HOSE DIAMETER		
Hose #	Decimal	Fraction	Hose #	Decimal	Fraction	Size	Decimal	Fraction	Size	Decimal	Fraction
#6	.440	7/16"	#6	.734	47/64"	-6	.562	9/16"	5/8	.906	29/32"
#8	.540	35/64"	#8	.890	57/64"	-8	.625	5/8"	3/4	1.015	1-1/64"
#10	.630	5/8"	#10	.969	31/32"	-10	.781	25/32"			
						-12	.906	29/32"			
						-16	1.125	1-1/8"			

## HOSE SEPARATOR SIZING CHART

Figures represent hose outside diameter measured in inches. These numbers match the available hose separator sizes.

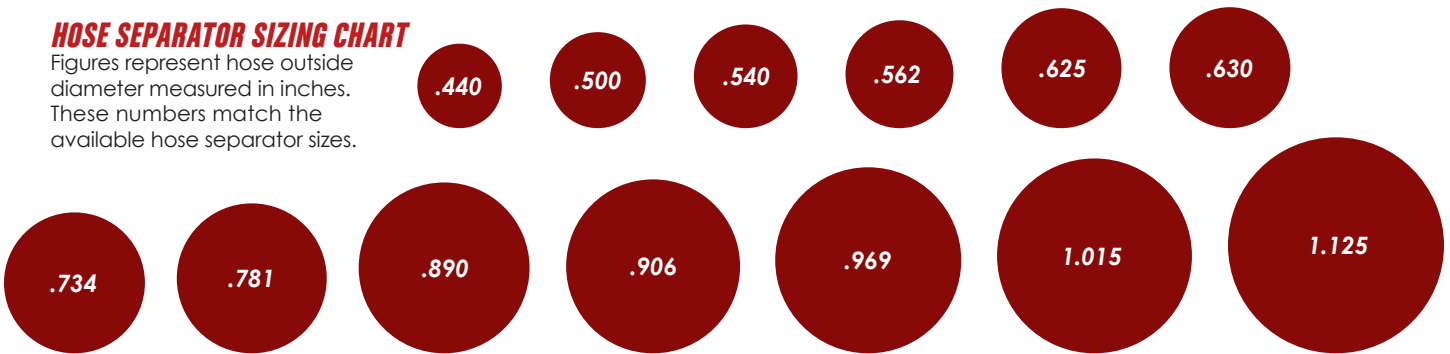

## THRU-FRAME FITTINGS

Machined from 303-stainless steel. Available for 2" & 2-3/8" wide frame rails. Sold in pairs.

- #66210 -3AN x 1/8" NPT Short (2")
- #66310 -3AN x 1/8" NPT Long (2-3/8")



## BILLET LINE CLAMPS

- Stainless bolts included
- Machined step to prevent twisting
- 3/16" & 1/4" include 8-32 x 5/8" bolts
- 5/16", 3/8" & 1/2" include 10-32 x 3/4" bolts

- #65110 3/16" Clamp
- #65210 1/4" Clamp
- #65310 5/16" Clamp
- #65410 3/8" Clamp
- #65510 1/2" Clamp

# BATTERY ACCESSORIES

Billet Specialties battery mounts secure your high performance battery with style. Machined from 6061-T6 billet aluminum for strength our battery mounts hold the battery firmly in place and provide a rigid base to mount to the vehicle. Billet Specialties offers an Optima and XS Power design each with two finish options.

## OPTIMA STYLE BATTERY MOUNTS

### Product Features:

- Stainless hardware Included
- Recessed bottom tray locks battery in place
- Fits Red or Yellow top Optima (Group 34/78)

#248910 Black/Clear Anodized

#248915 Fully Polished

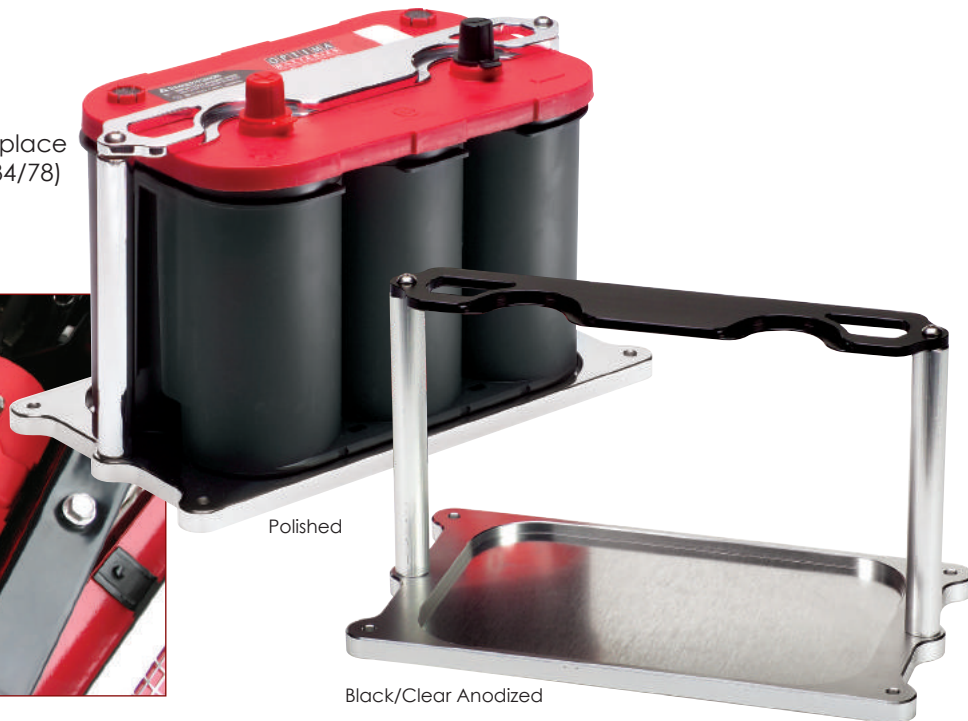

## XS STYLE BATTERY MOUNTS

### Product Features:

- Stainless hardware Included
- Recessed bottom tray locks battery in place
- Fits the following XS style batteries:
  - S1000 / D1000
  - S1600 / D1600

#248920 Black/Clear Anodized

#248925 Fully Polished



# HARDWARE

## STAINLESS PRO BOLTS

Developed by Rad Rides by Troy, these stainless fender washers were designed to avoid paint distortion during assembly and add style to your engine compartment.

### Product Features:

- Stainless hardware Included
- Sold in pairs

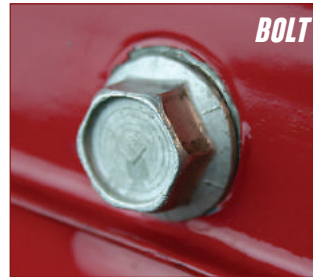

## BLACK

Part #	Bolt Size	Washer O.D.
#BLK66110	5/16-18 x 1"	3/4"
#BLK66120	3/8-16 x 1"	7/8"
#BLK66130	1/4-20 x 1"	11/16"
#BLK66140	10-24 x 1"	9/16"
#BLK66115	5/16-18 x 1"	1"

## BRUSHED

Part #	Bolt Size	Washer O.D.
#66110	5/16-18 x 1"	3/4"
#66120	3/8-16 x 1"	7/8"
#66130	1/4-20 x 1"	11/16"
#66140	10-24 x 1"	9/16"
#66115	5/16-18 x 1"	1"



"For over 20 years Walden Speed Shop has trusted Billet Specialties Quality and Finish."

- Bobby Walden  
Walden Speed Shop



# BILLET HOOD HINGES

'55-'56 CHEVROLET®

Billet Specialties hood hinges for the 55-56 Chevy feature precision 3D machining and look great at any angle. Available in three finish options of Raw Machined, Black Anodized and Full Polished, these hinges feature stainless hardware and precision bearings ensuring smooth operation. Sold in Pairs. Made in the USA.

**BILLET SPECIALTIES HOOD HINGES - TWO MORE REASONS TO KEEP YOUR HOOD OPEN!**

## Product Features:

- Follows OE Firewall Contours
  - Precision 3D Machined
  - Hood Closes Flush With Cowl
  - Stainless Hardware & Sealed Precision Bearings
- \*Gas Springs Sold Separately



Polished Finish

\*Shown with Polished Gas Spring  
#873510



Black Anodized Finish

\*Shown with Polished Gas Spring  
#BLK873510



Raw Machined Finish

\*Shown with Polished Gas Spring  
#N873510

Heavy Duty Gas Springs - Steel Hood Applications - 325lbs.

#3610HDSS Polished Stainless HD Gas Spring



# BILLET HOOD HINGES

'65-'67 CHEVELLE-EL CAMINO

Style from any angle -Billet Specialties billet hood hinges for the Chevelle/El Camino are the perfect upgrade to your engine compartment. The billet hinges feature precision 3D machining, premium stainless ARP 12 pt fasteners to match other Billet Specialties accessories and precision bearings for smooth operation. Sold in Pairs.

## Product Features:

- 6061-T6 aluminum construction
- Precision sealed bearings
- ARP 12pt. stainless hardware
- Multiple finishes available
- Made in the USA
- \* Gas Springs Sold Separately
- \* Will not work on cars with factory A/C



Polished Finish  
\*Shown with Polished Gas Spring  
#873610

Black Anodized Finish  
\*Shown with Polished Gas Spring  
#BLK873610

Raw Machined Finish  
\*Shown with Polished Gas Spring  
#N873610

## Heavy Duty Gas Springs - Steel Hood Applications - 325lbs

#3610HDSS Polished Stainless HD Gas Spring



## HOOD HINGE SPACERS FOR '66-'67 NOVA

Allows the use of Billet Specialties Camaro/Chevelle Hinges on 66-67 Nova's with aftermarket front clip and inner fender panels. Machined from 6061 -T6 aluminum the spacers mount seamlessly between the aftermarket inner fender and the hinge. Sold in pairs.

## Product Features:

- 6061-T6 Billet Aluminum
- Stainless hardware
- Made in the USA



Polished Finish  
#874410

Black Anodized Finish  
#BLK874410

Raw Machined Finish  
#N874410

# BILLET HOOD HINGES

'67-'69 CAMARO™

Billet Specialties leaves no detail unattended. Each hood hinge is precision 3D machined on both sides of the arms for style from any angle. ARP 12 pt. fasteners secure the precision bearing pivots. Stainless button head fasteners

### Product Features:

- 6061-T6 aluminum construction
- Precision sealed bearings
- ARP 12pt. stainless hardware
- Multiple finishes available
- Made in the USA
- \* Gas Springs Sold Separately



Polished Finish  
\*Shown with Polished Gas Spring  
#873610

Black Anodized Finish  
\*Shown with Polished Gas Spring  
#BLK873610

Raw Machined Finish  
\*Shown with Polished Gas Spring  
#N873610

Heavy Duty Gas Springs - Steel Hood Applications - 325lbs.  
#3610HDSS Polished Stainless HD Gas Spring



## BILLET DECK LID HINGES - '67-'69 CAMARO™

Add the finishing touch to the trunk area of your 67-69 Camaro, Billet Specialties billet deck lid hinges steal the show with 3D machining on both sides of the hinge and our exclusive hidden hardware to complete the smooth hi-tech look.

### Product Features:

- 6061-T6 aluminum construction
- Machined billet cover to hide hardware
- Delrin® pivot bushings
- Multiple finishes available
- Made in the USA
- \* Black Gas Springs Included



Precision machined covers snap into place and cover deck lid mounting hardware for the cleanest look available.

Polished Finish  
Black Gas Spring Included  
#875610

Black Anodized Finish  
Black Gas Spring Included  
#BLK875610

Raw Machined Finish  
Black Gas Spring Included  
#N875610

# BILLET HOOD HINGES

'70-'81 CAMARO™

Billet hood hinges done right - Billet Specialties unique knife edge styling looks great from any angle. Each hinge component is precision machined to not only look great but perform as well. Quality hardware including precision bearings for smooth operation as well as ARP stainless fasteners ensure years of trouble free operation. Billet Specialties hood hinges, just another two reasons to keep your hood open. Sold in pairs.

## Product Features:

- 6061-T6 aluminum construction
  - Precision sealed bearings
  - ARP 12pt. stainless hardware
  - Multiple finishes available
  - Made in the USA
- \* Gas Springs Sold Separately*

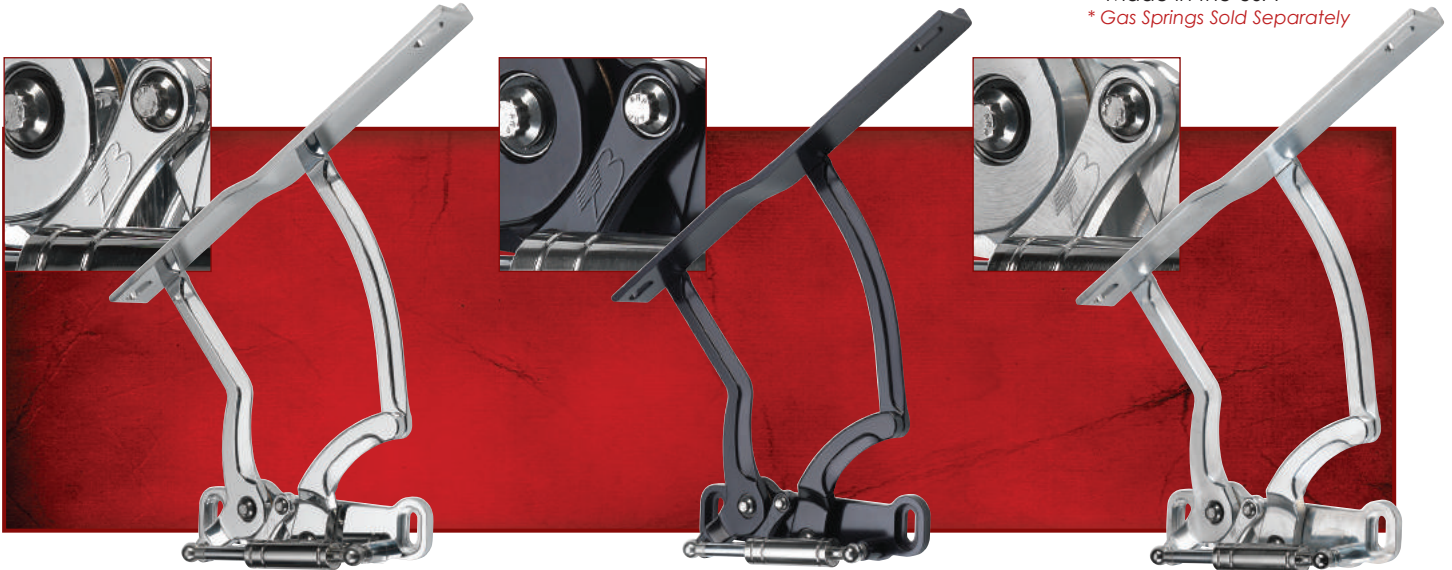

Polished Finish  
*\*Shown with Polished Gas Spring*  
#873620

Black Anodized Finish  
*\*Shown with Polished Gas Spring*  
#BLK873620

Raw Machined Finish  
*\*Shown with Polished Gas Spring*  
#N873620

## Heavy Duty Gas Springs - Steel Hood Applications - 325lbs.

#3610HDSS Polished Stainless HD Gas Spring



## FENDER BRACES- '67-'69 CAMARO™

Billet Specialties Fender Braces add high tech styling to your engine compartment while complementing the other Billet Accessories. Machined from 6061-T6 aluminum each brace kit includes aluminum mounting brackets and stainless hardware. Sold in pairs.

## Product Features:

- Precision 3D Machined surfaces
- Stainless hardware
- 6061-T6 aluminum construction
- Made in the USA



#872610  
#BLK872610  
#N872610

Polished  
Black Anodized Finish  
Raw Machined Finish



# GAS, BRAKE & CLUTCH PEDALS

'67-'69 CAMARO™/FIREBIRD

## Product Features:

- Gas pedal attaches directly to factory linkage location
- 1:1 Arm ratio for full range throttle operation
- Spring loaded gas pedal offers two mounting height options
- Stainless Hardware
- Gas pedal requires the use of a cable style linkage (not included)

**CONVERTS TO CABLE STYLE LINKAGE**



Pedestal attaches in factory firewall location.

CNC machined non-slip surface

### **GAS PEDAL ASSEMBLY**

- #199160 Polished
- #199165 Black Anodized
- \*Throttle Cable Not Included

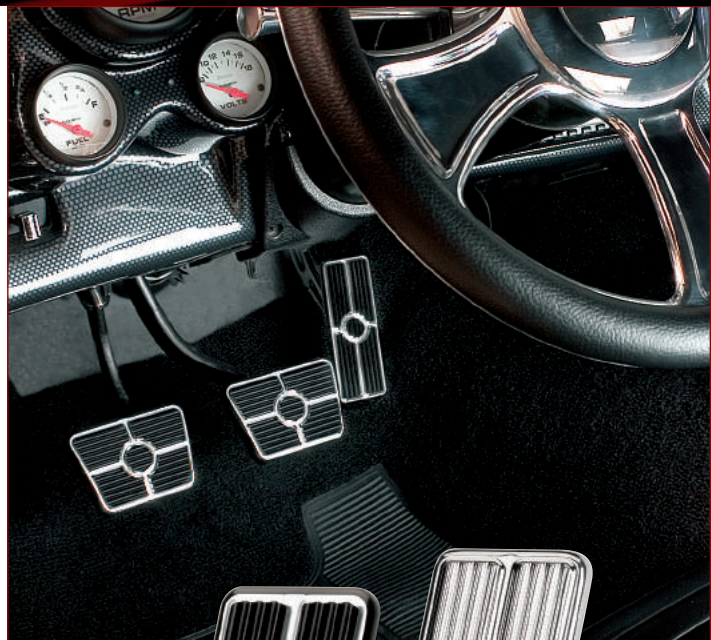

### **GAS PEDAL PAD**

- Replaces Factory Pedal
- #199260 Polished
- #199265 Black Anodized



### **E-BRAKE PAD**

- #199660 Polished
- #199665 Black Anodized

Dimensions: 2-5/16" W x 2-1/8" H

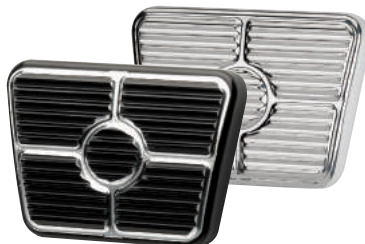

### **BRAKE/CLUTCH PAD**

- #199360 Polished
- #199365 Black Anodized

Dimensions: 3-7/8" W x 2-3/4" H

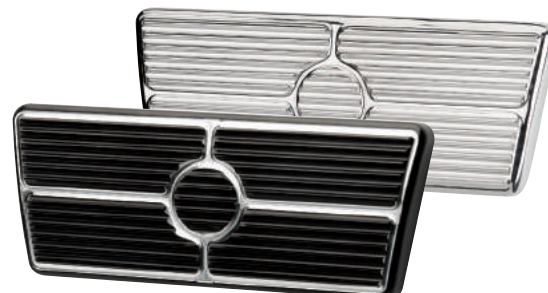

### **BRAKE PAD**

- #199460 Polished
- #199465 Black Anodized

Dimensions: 7" W x 2-11/16" H

**FITS OTHER APPLICATIONS - CALL!**



# TRI-FIVE CHEVY™ PEDALS

Add the finishing touch to the driver's compartment of your Chevy™ with these beauties. Gas, brake/clutch and dimmer are available in either durable black anodized or polished finishes.



**FLOOR MOUNT TRI-FIVE GAS PEDAL**  
 #199250 Polished  
 #199255 Black Anodized

**1-2-3 E-Z INSTALL**  
**1. REMOVE BOLTS**  
**2. REMOVE STOCK PEDAL**  
**3. BOLT IN NEW PEDAL**  
**YOU'RE DONE!**

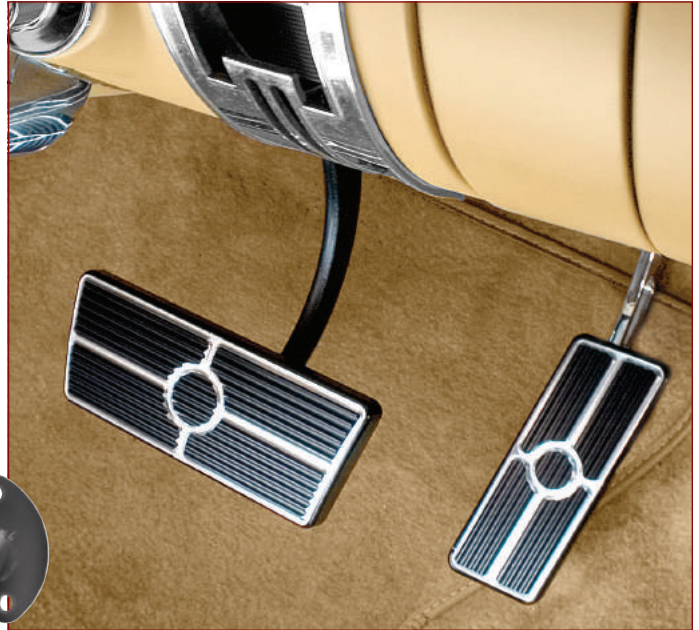

**CONVERTS TO CABLE STYLE LINKAGE**

## **GAS PEDAL ASSEMBLY**

Our billet gas pedal assembly converts your old throttle linkage to a more modern cable style linkage for extra firewall clearance and smooth operation.

### **Product Features:**

- Installs in factory firewall location with existing hardware
- Taller throttle arm improves engine clearance and cable angle
- Gas pedal pad has two mounting height options for added comfort
- Gas pedal includes aluminum washers to offset the throttle cable
- 1:1 pedal ratio - Works with all carburetors for full throttle range
- Spring loaded gas pedal - Just like late model OE
- CNC machined non-slip surface
- Stainless hardware included

## **GAS PEDAL ASSEMBLY FOR CABLE STYLE LINKAGE**

Gas Pedal Assembly for Cable Style Linkage  
 #199150 Polished  
 #199155 Black Anodized

*\*Throttle Cable Not Included*



## **DIMMER SWITCH COVER**

#199870 Polished  
 #199875 Black Anodized

Dimensions: .875" I.D.

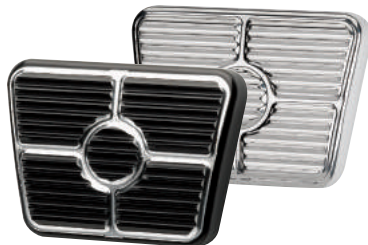

## **BRAKE/CLUTCH PAD**

#199350 Polished  
 #199355 Black Anodized

Dimensions: 3-7/8" W x 2-3/4" H

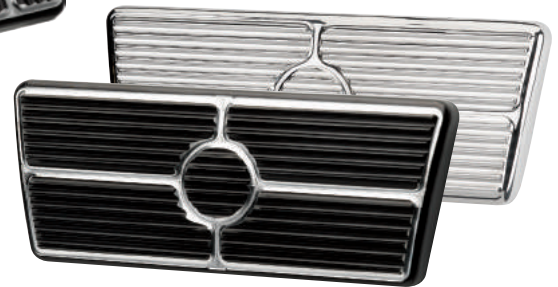

Dimensions: 7" W x 2-11/16" H

## **POWER BRAKE PAD**

#199450 Polished  
 #199455 Black Anodized

## **NON-POWER BRAKE PAD\***

#199550 Polished  
 #199555 Black Anodized

*\*Non-power brake pad sizes match the power brake pad size for added safety.*

# FULL SIZE CHEVY™ PEDALS

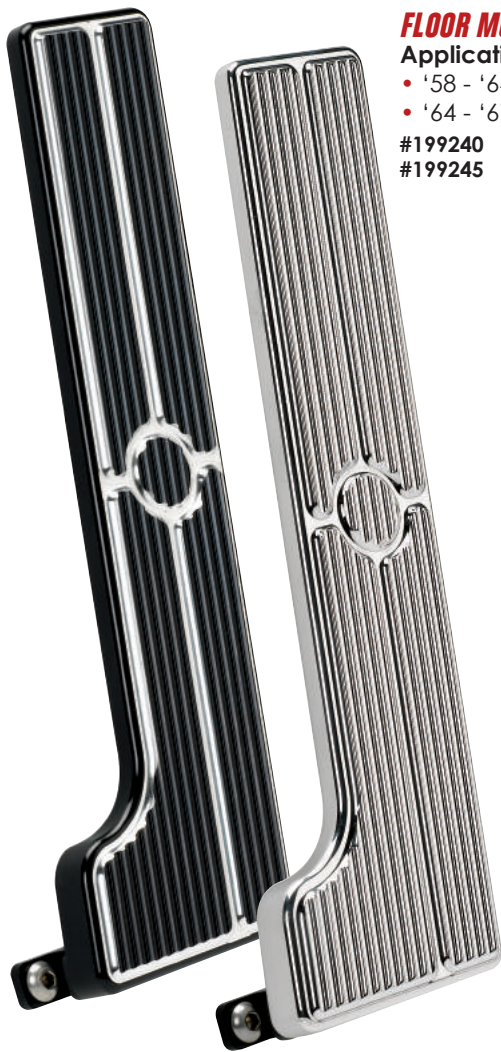

## FLOOR MOUNT FULL SIZE GAS PEDAL PAD

### Applications:

- '58 - '64 Bel Air™, Biscayne, Impala™
- '64 - '67 Nova®, Chevelle™, El Camino®

#199240 Polished

#199245 Black Anodized

## 1-2-3 E-Z INSTALL

1. REMOVE BOLTS
  2. REMOVE STOCK PEDAL
  3. BOLT IN NEW PEDAL
- YOU'RE DONE!**



## DIMMER SWITCH COVER

#199870 Polished

#199875 Black Anodized

Dimensions: .875" I.D.



## E-BRAKE PAD

### Applications:

- '58 - '64 Bel Air™, Biscayne, Impala™

#199640 Polished

#199645 Black Anodized

Dimensions: 2-7/8" W x 2-1/2" H

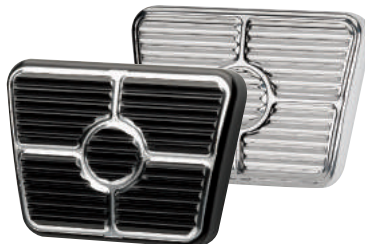

## BRAKE/CLUTCH PAD

### Applications:

- '58 - '65 Bel Air™, Biscayne, Impala™
- '63 - '67 Nova®, Chevelle™, El Camino®

#199340 Polished

#199345 Black Anodized

Dimensions: 3-7/8" W x 2-3/4" H

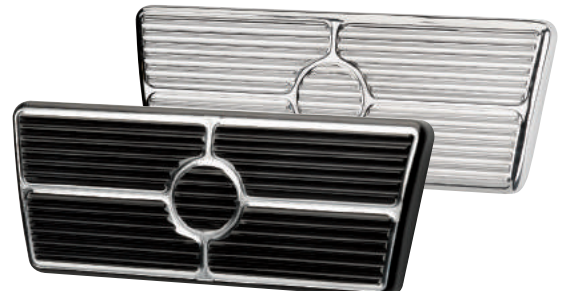

## BRAKE PAD

### Applications:

- '58 - '64 Bel Air™, Biscayne, Impala™
- '63 - '67 Nova®

#199450 Polished

#199455 Black Anodized

Dimensions: 7" W x 2-11/16" H

**FITS OTHER APPLICATIONS - CALL!**

# STREET ROD PEDALS

Reversible arm for extra floor clearance



Base offers left or right mounting positions

Fully adjustable



## RECTANGLE GAS PEDAL

- #199110 Polished
- #199115 Black Anodized

Dimensions: Pedal = 2.085" W x 4" H  
 Arm - Straight = 6 5/8  
 Arm - Curved = 6 3/4

## OVAL GAS PEDAL

- #199130 Polished
- #199135 Black Anodized

Dimensions: Pedal = 3.5" W x 2" H  
 Arm - Straight = 6 5/8  
 Arm - Curved = 6 3/4

## BRAKE/CLUTCH PADS

### Product Features:

- Backside offers two mounting positions Center or Offset
- 1/2-20 stud included for use with popular brake assemblies
- CNC machined non-slip surface



- #199310 Rectangle Polished
- #199315 Rectangle Black Anodized

Dimensions: 3-11/32" W x 1-15/16" H



- #199870 Polished
- #199875 Black Anodized

Dimensions: .875" I.D.

## BILLET DIMMER SWITCH COVERS

### Product Features:

- Machined non-slip surface
- Stainless steel set-screw design
- Fits Chevy™ & Ford applications

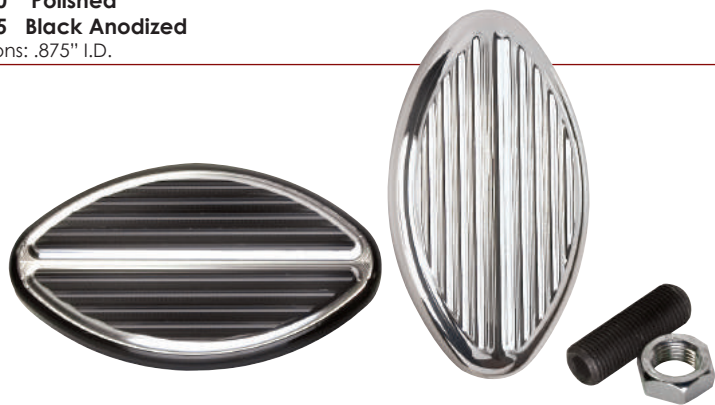

Oval pedals can be mounted vertical or horizontal

- #199330 Oval Polished
- #199335 Oval Black Anodized

Dimensions: 4" W x 1-11/16" H

# PROFILE PEDALS - UNIVERSAL

## BILLET GAS PEDAL ASSEMBLY

The ultimate pedals for your car! Billet Specialties Universal Profile Pedals are ideal for many applications that are not covered with our other pedals. The gas pedal's wide base ensures smooth, stable operation and fully adjustable arms allow precise throttle control and pedal height for multiple mounting situations. The brake, clutch and E-brake pedals include a steel base plate for welding to your pedal arms or use the included template to drill your existing pedal. Choose from either a polished or durable black anodized finish.

### Product Features:

- Modular design allows for custom backgrounds
- Embossed carbon vinyl insert included
- Wider mounting base for added stability
- 1:1 Arm Ratio for full range throttle operation
- Dual Delrin® bushings for smooth operation
- 3D CNC machined surface
- Spring loaded pedal
- Stainless hardware included
- Requires cable style throttle linkage (not included)



Base offers left or right mounting positions



Universal Profile Gas Pedal  
#199172 Polished  
Dimensions: 2" W x 5 1/2" H



Universal Profile Gas Pedal  
#199177 Black Anodized  
Dimensions: 2" W x 5 1/2" H

## UNIVERSAL PROFILE BRAKE & CLUTCH PEDALS

### Product Features:

- Modular design allows for custom backgrounds
- Embossed carbon vinyl insert included
- 3D CNC machined surface
- Includes steel mounting plates for installation
- Stainless mounting hardware included



Universal Profile Brake Pad  
#199472 Polished  
#199477 Black Anodized  
Dimensions: 7.5" W x 3" H



Universal Profile Brake/Clutch Pad  
#199372 Polished  
#199377 Black Anodized  
Dimensions: 4 1/4" W x 3" H



Universal Profile E-Brake Pad  
#199672 Polished  
#199677 Black Anodized  
Dimensions: 2 5/8" W x 2 1/2" H



#199860 Polished  
#199865 Black Anodized

Dimensions: .875" I.D.

## PROFILE BILLET DIMMER SWITCH COVERS

### Product Features:

- CNC machined aluminum
- Stainless steel set-screw design
- Fits Chevy™ & Ford applications

# UNIVERSAL PEDALS

## UNIVERSAL FLOOR MOUNT GAS PEDAL

Our universal floor mount pedal adds style and functional clearance for cramped engine compartments. Featuring adjustable pedal mount angle, pedal stop and pedal travel, this pedal works where others do not. Combine with matching pedals from our other applications to complete the set. Requires cable style throttle and appropriate carb linkage (not included). 1/2" pedal spacers available for added clearance.

### Product Features:

- 2-1/4" of travel
- Machined from 6061-T6 Billet Aluminum
- Polished or Black anodized finish
- Double nickel-plated cable bracket
- Stainless hardware and instructions included

#199270 Polished

#199275 Black Anodized

#199800 1/2" Spacer Polished

#199805 1/2" Spacer Black Anodized

Dimensions: 6 1/2" L x 2 1/2" W



## BILLET UNIVERSAL GAS PEDALS

### Product Features:

- Wider mounting base for added stability
- 1:1 Arm Ratio for full range throttle operation
- Dual Delrin® bushings for smooth operation
- CNC machined non-slip surface
- Spring loaded pedal
- Stainless hardware (included)
- Requires cable style throttle linkage (not included)

Universal Rectangle Gas Pedal

#199170 Polished

#199175 Black Anodized

Dimensions: 2" W x 5 1/2" H

Matching Brake & Clutch Pedals, See Page 88

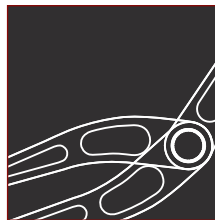

Reversible arm for extra floor clearance



Infinitely adjustable



## UNIVERSAL PEDAL KITS

Our 3pc. billet aluminum pedal covers add that finishing touch to the driver's compartment. Easy to use drill templates are included along with stainless hardware for a secure installation. Kits include covers for gas, brake and parking brake.

### Applications:

'73-'04 Dodge, Ford, & GM 1/2 & 3/4-ton trucks

### Dimensions:

Gas Pedal: 2.87"W x 6.18"H

Brake Pedal: 5.88"W x 2.92"H

Parking Brake: 2.23"W x 2.79"H

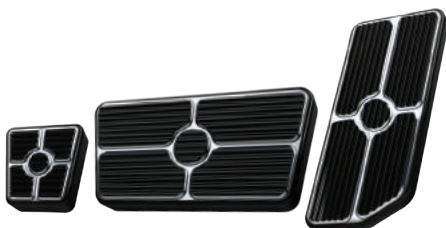

#198625 Grooved Black Anodized



#198622 Grooved Polished



#198620 Diamond Cut

# DOOR HANDLES & WINDOW CRANKS

## BILLET DOOR HANDLES & WINDOW CRANKS

Dress up your door panels with our billet aluminum door handles and window cranks. Easy installation and fully adjustable to any angle. Sold in pairs.

### Product Features:

- Installs in minutes
- Precision machined from 6061-T6 billet aluminum
- Industry leading mirror finish polish
- Steel splines & two set screws for secure installation

#RP4505 Replacement End Caps



### Door Handles - 3-3/4"L

Polished

- #45320 Ford to '48
- #45420 GM to '48
- #45520 GM/Ford '49 & Up

### Window Cranks - 3-3/4"L

Polished

- #46320 Ford to '48
- #46420 GM to '48
- #46520 GM/Ford '49 & Up

### Vent Cranks - 2-9/16"L

Polished

- #47320 Ford to '48
- #47420 GM to '48
- #47520 GM/Ford '49 & Up

## RAIL DOOR HANDLES & WINDOW CRANKS

CNC 3-D machined from billet aluminum for both strength and style, the Rail door handles and window cranks add a touch of style to any interior. Sold in pairs.

### Product Features:

- Installs in minutes
- Precision machined from 6061-T6 billet aluminum
- Industry leading mirror finish polish
- Steel splines & two set screws ensure secure installation



### Door Handles - 4-13/32"L

Polished

- #45328 Ford to '48
- #45428 GM to '48
- #45528 GM/Ford '49 & Up

### Window Cranks - 4-13/32"L

Polished

- #46328 Ford to '48
- #46428 GM to '48
- #46528 GM/Ford '49 & Up

### Vent Cranks - 3-5/32"L

Polished

- #47328 Ford to '48
- #47428 GM to '48
- #47528 GM/Ford '49 & Up

\*Tri-Five Chevy™ door panel trim will not allow proper functioning of vent window crank.

## SPLINE IDENTIFICATION

Lengths are measured from center of spline to end of handle/crank.

 Ford cars to '48  
Ford trucks to '52  
3/8" Square Spline

 GM to '48  
7/16" Round Spline

 GM/Ford '49 & Up  
1/2" Round Spline

## BALL MILLED DOOR HANDLES & WINDOW CRANKS

Ball milled handles feature an aggressive design for a high-tech look and an award winning polished or black anodized finish. Sold in pairs.

### Product Features:

- Installs in minutes
- Precision machined from 6061-T6 billet aluminum
- Industry leading mirror finish polish
- Steel splines & two set screws ensure secure installation



### Door Handles - 4-13/32"L

Polished

- #45325 Ford to '48
- #45425 GM to '48
- #45525 GM/Ford '49 & Up

### Window Cranks - 4-13/32"L

Polished

- #46325 Ford to '48
- #46425 GM to '48
- #46525 GM/Ford '49 & Up

### Vent Cranks - 3-5/32"L

Polished

- #47325 Ford to '48
- #47425 GM to '48
- #47525 GM/Ford '49 & Up

*\*Tri-Five Chevy™ door panel trim will not allow proper functioning of vent window crank.*

## KNOW THE DIFFERENCE

Billet Specialties' exclusive steel splined inserts are engineered to provide the most secure and durable attachment in the industry. Each steel insert offers precision machined splines to eliminate unnecessary play in the handle and is securely locked in position with two set screws. This is another great example of how far Billet Specialties goes to manufacture the best components for your car.

### Ours:

- High quality steel
- Precision machined
- Two set screws

### Theirs:

- Soft aluminum
- Stamped splines
- One set screw



## BLACK ANODIZED



### Door Handles - 4-13/32"L

Black Anodized

- #BLK45525 GM/Ford '49 & Up

### Window Cranks - 4-13/32"L

Black Anodized

- #BLK46525 GM/Ford '49 & Up

### Vent Cranks - 3-5/32"L

Black Anodized

- #BLK47525 GM/Ford '49 & Up

*\*Tri-Five Chevy™ door panel trim will not allow proper functioning of vent window crank.*

# DOOR PANEL ACCESSORIES

## '68-'69 CAMARO™ DOOR JAMB VENTS

Replace those plastic door vents on your 68-69 Camaro with a set of precision machined billet aluminum vents from Billet Specialties. Our billet vents feature a 3D machined design with a stainless mesh insert for cutting edge style. Includes stainless hardware.

### Product Features:

- Precision machined from 6061-T6 billet aluminum
- Polished, Black Anodized & Raw Machined finishes
- Made in the USA

#171100 Polished  
 #BLK171100 Black Anodized  
 #N171100 Machined Finish



## BILLET DOOR LOCK KNOBS

Machined from 6061-T6 billet aluminum and sold in pairs.

#45910 Smooth  
 Dimensions: 1-5/8" Tall  
 Thread: 10-24

#45930 Tri-Five  
 '55-'57, '59 & '60 Chevy™  
 Dimensions: 1-5/8" Tall  
 Thread: 6-40



## GRAB HANDLE/DOOR PULL

Great for muscle cars with flat door panels. Also a direct replacement for GM truck grab handles.

Dimensions: 8-1/2"L x 1-1/2"W  
 Holes are 6-3/4" center to center

- Direct Replacement For:**
- '94-'03 S-Series trucks
  - '95-'03 S-Series Blazer®
  - '88-'03 F/S Chevy™ trucks

- Product Features:**
- Universal billet aluminum design
  - Mirror polished finish
  - Stainless hardware included

#271020



# DASH PANEL ACCESSORIES

## TRIM STYLE DASH PANELS

The Trim Style's universal design allows the dash panel to be mounted with the machined ribs on the top or the bottom as shown. Accepts 3-3/8" dia. Tach or Speedo and 2-1/16" or 2-1/8" dia. gauges.

### Compatible with gauges from:

- Autometer®
- Classic Instruments®
- Stewart Warner
- VDO
- Ford Motorsport



**Trim Style - 5 Gauge Panel**  
15-1/4"W x 4-7/8"H x 3/8"D

**Trim Style - 6 Gauge Panel**  
19-1/4"W x 6"H x 3/8"D

#36525



#36535

## BILLET A/C VENTS

Fully adjustable machined vent rotates smoothly within a billet bezel.

### Product Features:

- Precision machined from 6061-T6 billet aluminum
- Polished to an industry leading mirror finish

### Dimensions:

Dash Opening: 2-1/2"

Hose Size: 2-1/2"

Outer Bezel: 2-3/4"

Mounting Depth: 1-7/8"

#38220 Silhouette

#38320 Slotted

Also available is a more economical air conditioning vent with billet aluminum bezel and plastic vent louvers.

#38110 Billet Bezel

**Note:** AC vents do not have a closed position to stop air flow.



## BILLET DASH KNOBS

Universal dash knobs work great to add that extra touch to your dash.

### Product Features:

- Precision machined from 6061-T6 billet aluminum
- Polished to a mirror finish
- 3/16" bore with set screw

#26002 Classic

#26003 Smooth



# SHIFT & COLUMN ACCESSORIES

## BILLET SHIFT ARM

Billet Specialties shift arms are designed to fit a wide range of GM vehicles. (Not for use with van columns)

### Product Features:

- Easy installation
- Precision machined from 6061-T6 billet aluminum
- Industry leading mirror finish polish
- Heat treated case hardened shaft end

#267320 '73-'94 Passenger Car

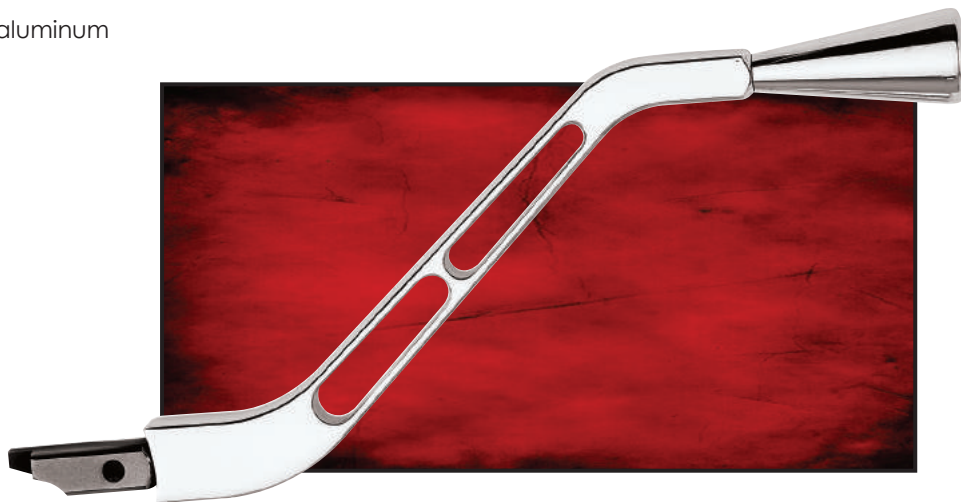
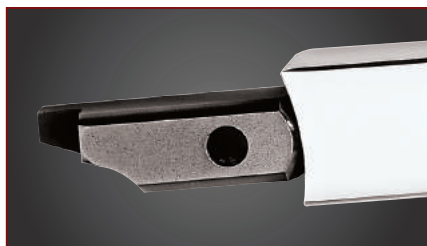

## COLUMN DRESS-UP KITS & COMPONENTS

Billet Specialties dress-up kits are a great way to detail your column. Featuring easy installation, precision machined 6061-T6 billet aluminum, polished or black anodized knob and polished stainless steel shafts.



Early Model Kit  
• Dimmer on floor  
#BLK26120 Black



Early Model Kit  
• Dimmer on floor  
#26120Polished



Late Model Kit  
• Dimmer on column  
#26320 Polished



Column Shift Knob  
#26220 Polished  
#BLK26220 Black

# SHIFT & COLUMN ACCESSORIES

## SHIFTER BOOT RING

Billet Specialties Shifter Boot Ring takes style to the next level. Machined from billet aluminum with mechanical styling our Shifter Boot Ring will bring all the interior details together. Includes stainless hardware and is available in two finish options Black Anodized or Polished finish. Fits leather or rubber shift boots. Made in the USA.

- Outside Dimensions: 5.75 x 7.125"
- Inside Dimensions: 4.125 x 5.5"

#279310 Polished  
#BLK279310 Black Anodized



Turn Lever with Knob  
#26023 Polished  
#BLK26023 Black



Tilt Lever with Knob  
#26022 Polished  
#BLK26022 Black



Flasher Knob  
#26021 Polished  
#BLK26021 Black



# HALF-WRAP

## BILLET STEERING WHEELS

We are the worldwide leader in billet steering wheels for many reasons. We offer the widest selection of styles, top grain leather colors, outstanding quality and fast delivery. Our relentless attention to detail is apparent both front and back on these works of automotive art.

The face of each half-wrap steering wheel boasts a custom front steering ring that is available in your choice of a wide array of leather colors, simulated burl wood or carbon fiber finishes. The backside of each wheel features milled finger notches for an ultra-comfortable grip. Designs are available in 14" & 15.5" diameter and will fit in most any vehicle imaginable.



# 4 PARTS ARE REQUIRED FOR EVERY STEERING WHEEL PACKAGE...

### STEERING WHEEL



Choose a half-wrap billet steering wheel style

### HALF-WRAP RING



Choose a leather or simulated finish half-wrap

### HORN BUTTON



Choose a horn button that fits your style

### COLUMN ADAPTER



Choose an adapter that fits your application



# STEERING WHEEL CONFIGURATOR



**SEE WHAT IT LOOKS LIKE BEFORE YOU BUY IT!**

- 1. SELECT YOUR STEERING WHEEL**
- 2. SELECT YOUR HALF WRAP**
- 3. SELECT YOUR HORN BUTTON**
- 4. SELECT YOUR COLUMN ADAPTER**

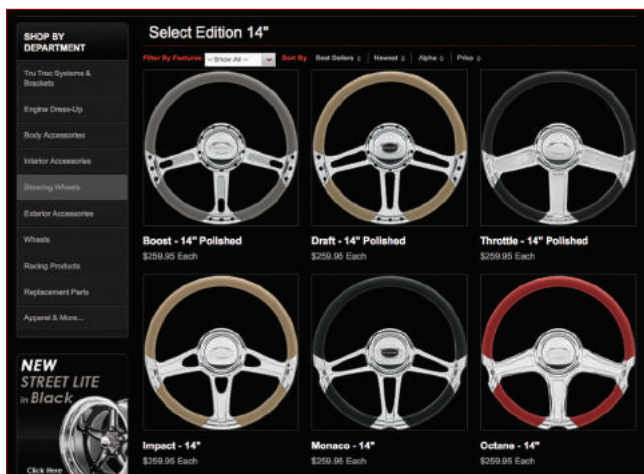

**TOP GRAIN LEATHER HALF-WRAPS PLUS SIMULATED FINISHES**

**CHOOSE FROM OVER 40 STEERING WHEEL DESIGNS**

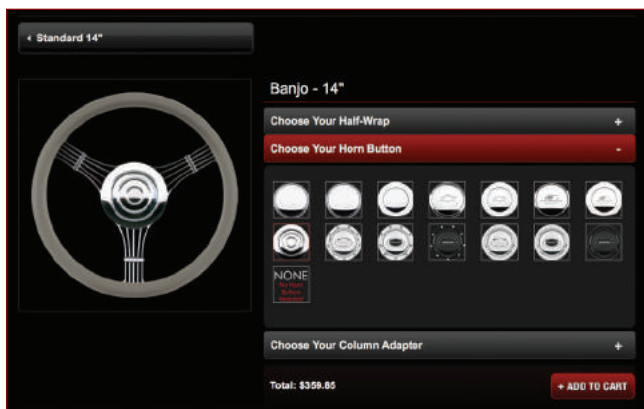

**MULTIPLE HORN BUTTON STYLES AVAILABLE**

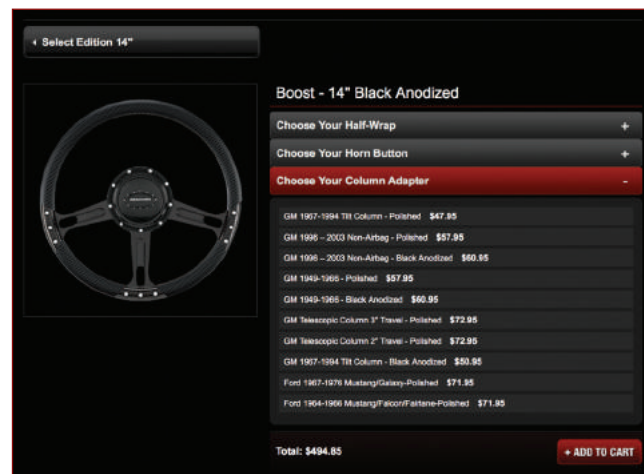

**POLISHED AND BLACK ANODIZED FINISHES**

# FLAT OUT

## 14" BILLET STEERING WHEELS

Traditional style for traditional columns, our Flat Out Steering Wheels are a direct bolt-on to early steering columns via 3 stainless fasteners hidden under an O-ring button cap. Select one of our top grain leather half wraps to finish the wheel off or have a plain ring wrapped to match your interior.

### Features:

- 14" diameter
- 3-hole mount fits traditional steering columns
- 6061-T6 billet aluminum
- Half-wrap design with milled finger grips
- Includes button cap



Sprint  
#29540



LSR  
#29520

### HALF-WRAP RINGS

Wrap up the details with genuine leather half-wrap rings for Billet Specialties steering wheels.

Black Leather  
14" #29008

Light Gray Leather  
14" #29003

Dark Gray Leather  
14" #29004

Tan Leather  
14" #29002

Red Leather  
14" #29005

Embossed Carbon Vinyl  
14" #29013

Simulated Burl Wood  
14" #29012

Blank - No Leather  
14" #29000

For Custom Wrap Applications

# D-SHAPED 14" BILLET STEERING WHEELS

D-Shaped steering wheels offer race inspired design matching today's trends with Billet Specialties quality. Each wheel is precision 3D machined from 6061-T6 aluminum with milled finger notches and aggressive style. Each wheel includes both black and polished rivets allowing you to customize the final look. Select from four top grain leather choices plus simulated Carbon Fiber or wrap your own with a blank wrap to match your interior.

**Features:**

- Race inspired D-shaped design
- Precision 3D machined
- Milled finger notches
- Polished or black hard anodized finish

**INCLUDES:  
Both Polished & Black Rivets!**



\* See Pro Style horn buttons located on page 112



Formula - Contrast Cut  
#BC29409



Formula - Black Anodized  
#BLK29409



Formula - Polished  
#29409



Camber - Polished  
#29402



Camber - Black Anodized  
#BLK29402

**D-SHAPED HALF-WRAPS**

Precision machined from 6061-T6 billet aluminum then covered in top grain leather or Embossed Carbon Vinyl. Each piece precisely fits into place and is secured with stainless hardware.

Tan  
#28702

Light Gray  
#28703

Red  
#28705

Black  
#28708

Embossed Carbon Vinyl  
#28713

Blank – No Leather  
#28700

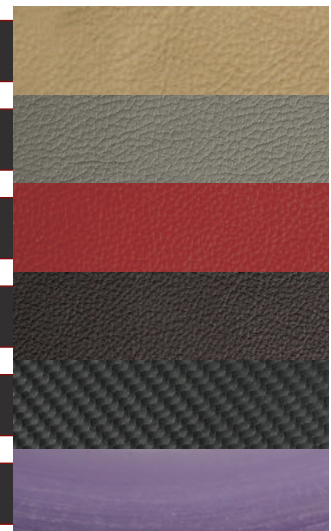

# SELECT EDITION

## 14" BILLET STEERING WHEELS

**GOOD GUYS** 2011  
New Product WINNER!

Once again Billet Specialties leads the way with the Select Edition line of steering wheels. Precision machined from 6061-T6 billet aluminum, each wheel features segmented half wraps for an aggressive style. The Boost, Throttle and Draft include polished and black rivets allowing you to customize your steering wheel to achieve your own unique look.

Select Edition. Truly Custom.



Throttle - Black Anodized  
#BLK29299



Throttle  
#29299



Draft - Black Anodized  
#BLK29263



Draft  
#29263



Boost - Black Anodized  
#BLK29244



Boost  
#29244

**PRICE SHOWN IS FOR STEERING WHEEL ONLY**  
Half wraps for Select Edition available to the right





**PRO STYLE HORN BUTTONS**

Six styles to compliment the Select Edition steering wheels as well as our other steering wheels. The Pro Style horn buttons feature either a smooth elegant style or more aggressive riveted look that includes both polished and black rivets you install to customize your look even further.



Monaco  
#29315



Octane  
#29308



Impact  
#29301



Riveted / Polished Logo  
#32710

Riveted / Black Logo  
#32715

Riveted / Black Anodized  
#32719



Smooth / Polished Logo  
#32720

Smooth / Black Logo  
#32725

Smooth / Black Anodized  
#32729

**\*Pro Style horn buttons are not for use with Stiletto, Rail or Rat Tail Profile Steering wheels.**

**SELECT EDITION HALF-WRAPS**

Precision machined from 6061-T6 billet aluminum then covered in top grain leather or Embossed Carbon Vinyl. Each piece precisely fits into place and is secured with stainless hardware.

Tan  
#28602

Light Gray  
#28603

Red  
#28605

Black  
#28608

Embossed Carbon Vinyl  
#28613

Blank – No Leather  
#28600

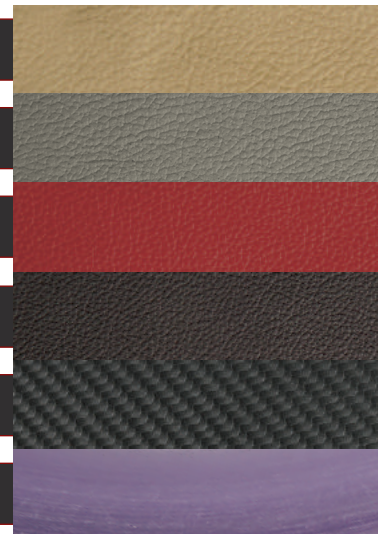

# PROFILE COLLECTION

## BILLET STEERING WHEELS

The Profile collection brings forth a revolutionary take on steering wheel design. Each of these wheels feature a half-wrapped and fully polished aluminum wheel with milled finger notches on the backside and a premium leather front. Polished billet aluminum accent pieces raise up from each spoke and flow out over the leather half-wrap ring and horn button for a bold new look that will add award winning detail to your ride's interior.



Fury  
#P30017 14" Diameter

\*All Billet Specialties horn buttons work with this steering wheel

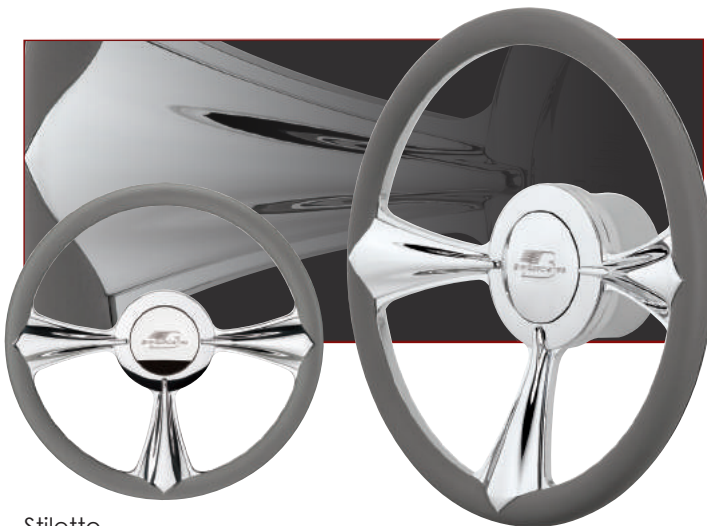

Stiletto  
#P30092 14" Diameter  
#P34092 15.5" Diameter

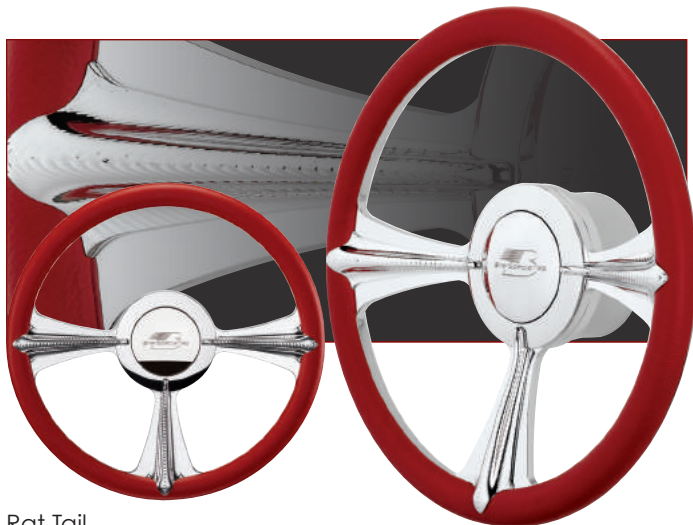

Rat Tail  
#P30097 14" Diameter  
#P34097 15.5" Diameter

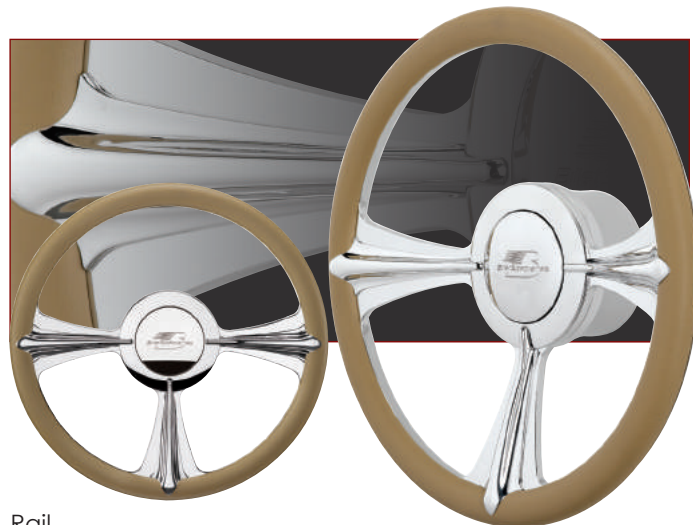

Rail  
#P30096 14" Diameter  
#P34096 15.5" Diameter



Large Billet Logo

Large Bowtie

Large Plain

Profile steering wheels are engineered to work with Billet Specialties large horn buttons, leather half-wraps, and steering column adapters. Not for use with simulated burl wood half-wrap rings.

**PRICE SHOWN IS FOR STEERING WHEEL ONLY**

Steering wheels require the purchase of a half-wrap, horn button, & adapter. See pages 111-113.

# 14" HALF-WRAP

**BILLET STEERING WHEELS**



Banjo  
#30925



Split Spoke  
#30137



Rival  
#30735



Interceptor  
#30595



Street Lite - Black  
#BLK30103



Street Lite  
#30103

**PRICE SHOWN IS FOR STEERING WHEEL ONLY**  
Steering wheels require the purchase of a half-wrap, horn button, & adapter. See pages 111-113.

# 14" HALF-WRAP

## BILLET STEERING WHEELS



Classic  
#30725



Chicayne  
#30765



Outlaw  
#30445



Anthem  
#30976



Speedway  
#30973



Edge  
#30971

**PRICE SHOWN IS FOR STEERING WHEEL ONLY**

Steering wheels require the purchase of a half-wrap, horn button, & adapter. See pages 111-113.



GTX01  
#30935



Vintec  
#30425



Eagle  
#29825



Fast Lane  
#30175



Sniper  
#30955



Steering Wheel Accessories  
see page 111-113

**PRICE SHOWN IS FOR STEERING WHEEL ONLY**

Steering wheels require the purchase of a half-wrap, horn button, & adapter. See pages 111-113.

# 15.5" HALF-WRAP

## BILLET STEERING WHEELS

Take control of your muscle car or classic with our 15-1/2" diameter steering wheels from Billet Specialties. Designed for proper proportion and leverage needed with larger vehicles, our precision machined steering wheels feature milled finger notches and leather front rings just like our best selling 14" wheels.

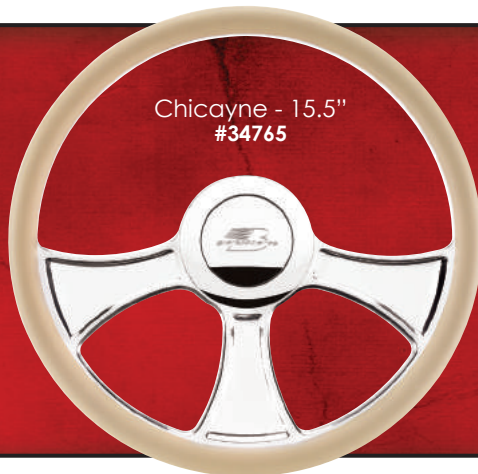

**PRICE SHOWN IS FOR STEERING WHEEL ONLY**

Steering wheels require the purchase of a half-wrap, horn button, & adapter. See pages 111-113.

# HALF-WRAPS

## HALF-WRAP RINGS

Wrap up the details with genuine leather half-wrap rings for Billet Specialties steering wheels.



Black Leather  
14" 29008  
15.5" 33008



Light Gray Leather  
14" 29003  
15.5" 33003



Dark Gray Leather  
14" 29004  
15.5" 33004



Tan Leather  
14" 29002  
15.5" 33002



Red Leather  
14" 29005  
15.5" 33005



Embossed Carbon Vinyl  
14" 29013  
15.5" 33013



Simulated Burl Wood  
14" 29012  
15.5" 33012



Blank - No Leather  
14" 29000  
15.5" 33000

For Custom Wrap Applications

\*Leather photos shown may differ from actual color.

Our half-wrap rings feature top grain leather that is selected in-house and hand-cut for superior quality.



# HORN BUTTONS & ADAPTERS

## PRO STYLE HORN BUTTONS

Six styles to compliment the Select Edition steering wheels as well as our other steering wheels. The Pro Style horn buttons feature either a smooth elegant style or more aggressive riveted look that includes both polished and black rivets you install to customize your look even further.

Not for use with Rail, Rat Tail or Stiletto steering wheels

### Product Features:

- Precision machined 6061-T6 billet aluminum
- Durable polished and black anodized finishes available
- Stainless internal hardware
- Riveted horn buttons include polished and black rivets

INCLUDES:  
Both Polished & Black Rivets!



Riveted - Polished Logo  
#32710



Riveted - Black Logo  
#32715



Riveted - Black Anodized  
#32719



Smooth - Polished Logo  
#32720



Smooth - Black Logo  
#32725



Smooth - Black Anodized  
#32729

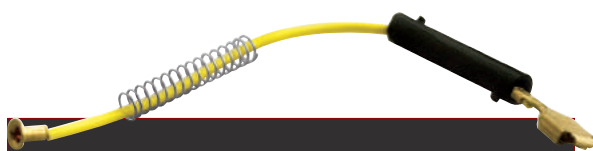

### Replacement Horn Wire Lead

#RP2510

Some aftermarket steering columns do not include this wire





## BILLET HORN BUTTONS

Billet Specialties dome style horn buttons fit our billet steering wheels and other aftermarket 9-hole steering wheels. Standard size horn buttons leave the steering wheel mounting screws exposed while the large horn buttons cover them up.

### Product Features:

- Precision machined 6061-T6 billet aluminum
- Industry leading polished finish
- Stainless internal hardware

\* Some Ford applications require a dual contact horn button. Call For Applications.

### NOTE:

Profile Steering wheels require the use of a LARGE horn button, shown below.



Standard - Billet Logo  
#32620

Standard - Bowtie  
#32320

Standard - Plain  
#32120  
#32121\*



Large - Banjo  
#32925

Large - Billet Logo  
#32625

Large - Bowtie  
#32325

Large - Plain  
#32125

## BILLET STEERING WHEEL ADAPTERS

Engineered to fit most GM applications.

### Product Features:

- Precision machined from 6061-T6 billet aluminum
- Industry leading mirror finish polish or Black Anodized Finish
- Polished stainless steel mount screws (8/32" x 5/8")
- '49-'66 adapter includes cancel cam for '55-'56 columns



**CALL FOR OTHER APPLICATIONS**

Part #	Column Type	
#31120	GM 1967-1994 Billet Specialties, Ididit, F. River	Most Applications
#31126	GM 1996-2003	Non-Air Bag
#31322	GM 1949-1966	Most Applications
#31324	GM Telescopic*	2" Travel
#31323	GM Telescopic*	3" Travel
#31120	Billet Specialties, Most Ididit, Flaming River	
#BLK31120	GM 1967-1994 Billet Specialties, Ididit, F. River	Black Anodized
#BLK31126	GM 1996-2003	Black Anodized
#BLK31322	GM 1949-1966	Black Anodized
#31000-900	Replacement Adapter Screw Kit	

\* Telescoping adapters are designed for steering columns with a telescoping function. Telescoping adapters do not add this function to a steering column.

# PROFILE MIRROR KITS

Add timeless style with Billet Specialties forged 6061-T6 aluminum Profile Mirror Kits. Forged for ultimate strength, 3-D machined and mirror polished for style. Profile mirror arms feature multiple mounting holes for a secure fit and can be used for top or bottom mount applications.

## Product Features:

- Precision machined from forged 6061-T6 aluminum
- Industry leading mirror finish polish
- High quality glass for distortion free viewing
- Stainless steel swivel with a nylon bushing for smooth positive adjustment
- Stainless steel 10-24 button head screws included

Multiple mount options



## Dimensions:

- Base: 1-1/2"W x 21/32"H
- Profile mirror overall arm length 6"
- From mounting surface out to pivot point 4"



**Oblique  
Mirror Heads**

#74820 Oblique



**Offset Round  
Mirror Heads**

#74720 4" Offset Round

**TECH TIP**

Offset mirrors allow for increased angle of adjustment. Mirror arms can be used as top or bottom mounts by switching driver and passenger mounting positions.



**Offset Oval  
Mirror Heads**

#74920 Offset Oval



**Oval  
Mirror Heads**

#74520 Oval



**Round  
Mirror Heads**

#74120 3-1/8" Round

# INTERIOR MIRRORS

## INTERIOR MIRRORS & MOUNTS

Complement your interior with a billet aluminum rear view mirror from Billet Specialties. Rectangle or our classic oval design mirrors are available along with two interior mirror mounts. *Glue on mirror mount is designed for vertical or slightly angled windshields only.*

### Product Features:

- Precision machined from 6061-T6 billet aluminum
- Top quality glass for clear viewing
- Stainless steel swivel with nylon inserts for smooth accurate adjustments
- Industry leading polished finish

#73420 Rectangle

#73520 Oval

#72220 Bolt-on mirror mount

#72120 Glue-on mirror mount  
(Adhesive Included)



- 1.75" Tall
- Holes are 2" center to center



### Mirror Head Dimensions

- Rectangle 1-3/4" x 5-1/4"
- Oval 2-5/16" x 4-3/16"

## BILLET REAR VIEW MIRRORS

Our rear view mirrors are an easy bolt on replacement for the factory windshield mounted mirrors in most vehicles. These rearview mirrors have a universal mount that simply slips over the factory glued-on windshield mount.

### Approximate Dimensions:

9-3/8" W x 2-7/16" H



#257330 Ball Milled



#257340 Bowtie



#257820 Flame



# INTERIOR LIGHTING

## **BILLET INTERIOR LIGHTS**

Billet Specialties interior lights provide ample light for use in consoles and headliners.

### **Product Features:**

- Machined from 6061-T6 billet aluminum
- Mirror polished billet bezel
- Easy Installation

### **Dimensions:**

Rectangle Lights: 1-1/4"H x 3-5/8"W x 1-1/16"D

Elliptical Lights: 2"H x 4"W x 1-1/2"D

#60320 Elliptical - Interior Light

#60120 Rectangle - Interior Light

#RP6413 Replacement Bulb 5-watt



Elliptical  
Interior Light

Rectangle  
Interior Light

## **BILLET DOOR LIGHTS**

### **Product Features:**

- Machined from 6061-T6 billet aluminum
- Mirror polished billet bezel
- Easy Installation

### **Dimensions:**

Rectangle Lights: 1-1/4"H x 3-5/8"W x 1-1/16"D

Elliptical Lights: 2"H x 4"W x 1-1/2"D

#60420 Elliptical - Door Light

#60220 Rectangle - Door Light

#RP6413 Replacement Bulb 5-watt



Elliptical  
Door Light

Rectangle  
Door Light

# EXTERIOR LIGHTING

## UNIVERSAL LED TAILLIGHTS

Billet Specialties taillights feature either Vintage or Smooth styling in a clean easy to install package. Billet aluminum bezels are precision machined from 6061-T6 aluminum and polished to perfection. One piece safety lenses and steel housings complete the package. Each pair of tail lights includes two 1157 LED bulbs for safety. Sold in pairs.

### Product Features:

- LED bulbs
- 1 pc. Safety Lens
- 6061-T6 Billet Aluminum
- Made in the USA

#61330

Vintage Polished Bezel

#61340

Smooth Polished Bezel



## BILLET BEZEL TAILLIGHTS

Billet Specialties taillights offer a custom look and safety for the back end of your hot rod. One piece safety lenses and steel housings complete the package. Each pair of tail lights includes two 1157 LED bulbs for safety. Sold in pairs.

### Product Features:

- Machined bezels from 6061-T6 billet aluminum
- 3-3/4" deep steel housing
- Industry leading mirror finish polish
- Includes LED 1157 bulb

#61125

Split Bezel/Pair

#61225

Open Bezel/Pair

#61000-900

Taillight Lenses/Pair



## OVAL THIRD BRAKE LIGHT

### Product Features:

- Precision machined from 6061-T6 billet aluminum
- Industry leading mirror finish polish
- Swivel base for proper angle adjustment

**Dimensions:** 7"W x 1-3/4"H x 9/16"D

**Mounting Surface:** 2"W x 1/2"D

#62220

Oval Third Brake Light

#RP6211

Third Brake Light Lens w/ Screws

#RP6411

Replacement 10w bulb 2-pack

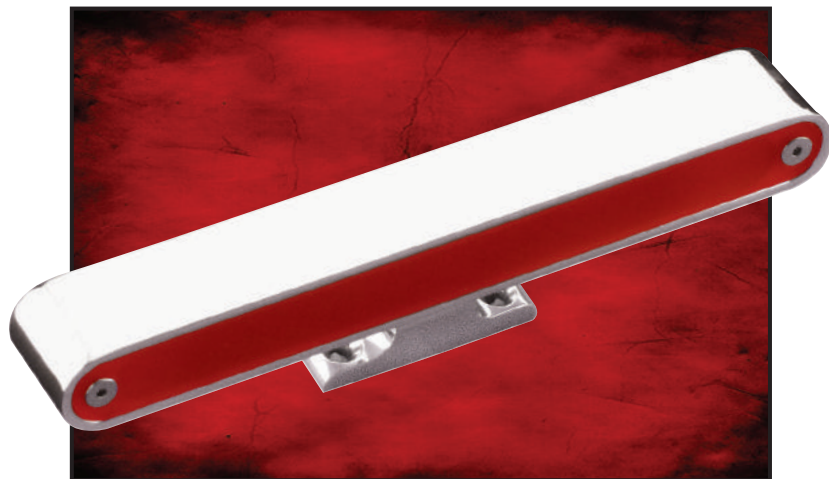

### 1969 CAMARO RECESSED TALLIGHT BEZELS

Billet Specialties Taillight Bezels for the 69 Camaro are precision 3D machined from Billet aluminum for a High-Tech look. Not your ordinary cookie cutter machining, Billet Specialties bezels feature thousands of tool paths to blend hard edges into fluid style. Available in two models, traditional slotted and segmented tri-panel. Made in the USA. Sold in pairs.

#61730                    Segmented Polished Bezel  
#CS61730                Segmented Chrome Bezel

#61732                    Slotted Polished Bezel  
#CS61732                Slotted Chrome Bezel

**AVAILABLE WITH  
CHROME PLATED BEZELS!**



Slotted Bezel

Segmented Bezel

### RECESSED BEZEL

### 1969 CAMARO RS FLUSH TALLIGHT BEZELS

Different from our recessed taillights, our flush mount bezels offer a smooth clean look for the back of your Camaro. Each tail light is precision machined from 6061-T6 billet aluminum for a High-Tech look. Two styles are available; traditional slotted and segmented tri-panel. Made in the USA. Sold in pairs.

#61735                    Segmented Polished Bezel  
#CS61735                Segmented Chrome Bezel

#61737                    Slotted Polished Bezel  
#CS61737                Slotted Chrome Bezel

**AVAILABLE WITH  
CHROME PLATED BEZELS!**



Segmented Bezel

Slotted Bezel

### FLUSH BEZEL

#### Product Features:

- Precision 3D machined
- 1pc. cast acrylic lens
- 6061-T6 billet aluminum
- Stainless hardware

#### Product Features:

- Precision Machined Bezel
- Stainless Hardware
- 1 pc. Cast Acrylic Lens
- 6061-T6 Billet Aluminum

# EXTERIOR ACCESSORIES



## **BILLET RECESSED LICENSE PLATE FRAME**

Machined on both sides from 6061-T6 billet aluminum our billet license plate frames are the perfect measure of form and function. Each frame is given a polished, mirror-like finish and includes stainless hardware.

Recessed frames sit around the license plate for a smooth look.

- #55120 Plain - Recessed
- #55623 Bowtie - Recessed

Dimensions: 12-5/8" W x 6-7/8" H



## **LIGHTED RECESSED FRAMES**

Lighted Billet Specialties recessed license frames illuminate your plate with style

- #55220 Lighted - Plain Recessed
- #55520 Lighted - 3rd Brake Recessed
- #55320 Lighted - Bowtie Recessed

Dimensions: 12-5/8" W x 6-7/8" H



## **POLISHED SLIM LINE FRAME**

Billet Specialties Slim Line license frame match the outside dimensions of a standard license plate and fits well in tight spaces, including GM front license plate mounts. This frame is not recessed.

- #55020 Polished - Slim Line
- #BLK55020 Black - Slim Line

Dimensions: 12-3/8" W x 6-5/8" H



**POLISHED OR BLACK POWDER COATED FINISH**



### '68-'69 CAMARO SS HOOD VENTS

Billet Specialties SS hood vents are the perfect match to our other great Camaro accessories. Precision 3D Machined from billet aluminum on multi axis CNC equipment, each hood vent features stainless mesh grill and drain holes. Includes stainless hardware and is ready to install. Sold in pairs.

#### Product Features:

- 6061-T6 Billet Aluminum
- Stainless Hardware & Mesh Grills
- Made in the USA

#876610 Polished



### WINDSHIELD WIPER POST COVERS

Not running wiper arms? Cover those posts with our polished billet wiper post covers. Sold in pairs.

#### Applications:

**11/16"**  
**.6875**

Set-screw design  
uses 11/16" or smaller shaft

- #248810 Bullet Style / Post Style
- #248815 Ribbed Style / Post Style



### BILLET TRAILER HITCH COVER

The face plates of our hitch covers are CNC machined from 6061-T6 aluminum and polished to a mirror finish, the back piece is 2" square steel tube. Installation takes a matter of seconds to make your truck's detail complete all the way around. *Pin Not Included.*



#210120 Bowtie Cutout

# ONLINE WHEEL VISUALIZER

**TEST DRIVE OUR WHEEL VISUALIZER  
SEE WHAT IT LOOKS LIKE  
BEFORE YOU BUY IT!**

## STEP 2 SELECT YOUR WHEELS

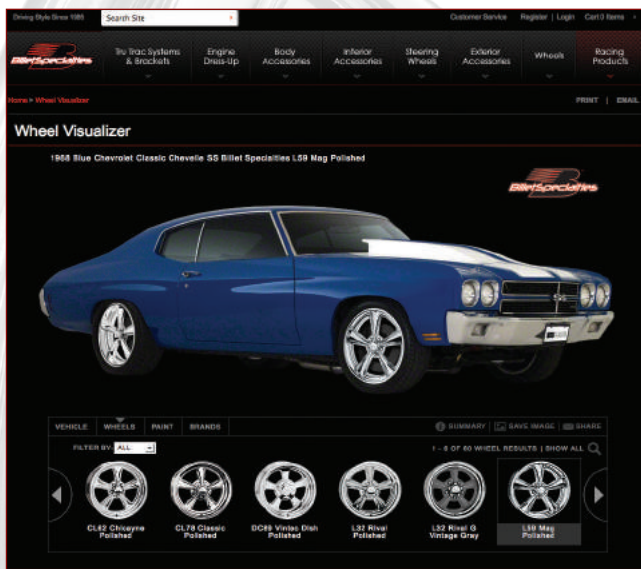

## STEP 1 SELECT YOUR MAKE, MODEL, AND YEAR

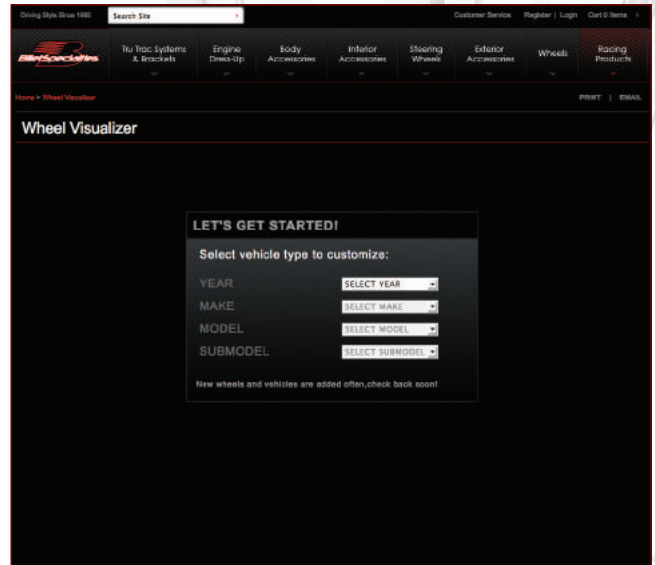

## STEP 3 SAVE, PRINT OR SHARE RESULTS



# WHEELS



"Cotati Speed Shop is always focused on the quality and end result of our builds. With their expansive line of products, unsurpassed quality and attention to detail, Billet Specialties helps us to get the job done every time"

- ZANE CULLEN - COTATI SPEED SHOP



Billet Specialties American Made quality and craftsmanship shines in every product they make.

- Lonny Gordon  
East Coast Muscle Cars



# CONCAVE PRO TOURING SERIES

**Cones, Corners or Car Shows, We've Got You Covered.....**

Billet Specialties Concave Pro Touring Series of wheels are not only aggressively styled, they are incredibly light. Choose from six available styles and two concave center profiles.



### Light is Right!

Here is a close up of the bolt pad showing the relief cuts made to reduce unnecessary weight from the center.

Concave Deep    Concave Shallow

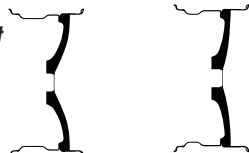

Select Concave Shallow for the front and Concave Deep in the rear for the Ultimate Stagger & Stance

### Even More Weight Savings!

Without the weight penalty of fasteners or rim flanges, our two piece welded construction saves even more weight over a three-piece wheel.

### Select From 7 AVAILABLE FINISHES

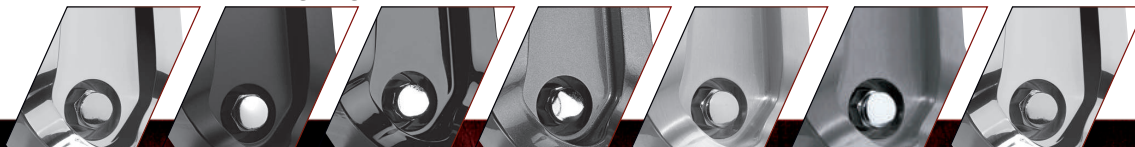

POLISHED

MATTE BLACK

GLOSS BLACK

GUNMETAL

CLEAR OVER FULL SATIN

BRUSHED SMOKE CLEAR

CLEAR OVER FULL POLISH



**Camber in Concave Deep**

18 • 19 • 20

Gunmetal Gloss Shown

# CAMBER

18x8 from 18.5 lbs!



**Camber in Concave Shallow**

18 • 19 • 20

Polished Shown

**BIG BRAKE READY**

Caliper Clearances  
Up to 1-3/4



# GTR

18x8 from 19.5 lbs!



**GTR in Concave Deep**  
18 • 19 • 20  
Brushed Clear Shown



**GTR in Concave Shallow**  
18 • 19 • 20  
Gunmetal Gloss Shown



**Hydro in Concave Shallow**  
18 • 19 • 20  
Brushed Clear Shown

# HYDRO

18x8 from 20 lbs!



**Hydro in Concave Deep**  
18 • 19 • 20  
Brushed Smoke Clear Shown

# CONCAVE PRO TOURING SERIES



63 Nova

Featuring:  
Razor Concave Shallow up front  
with Concave Deep out back.



Select From  
**7 AVAILABLE FINISHES**

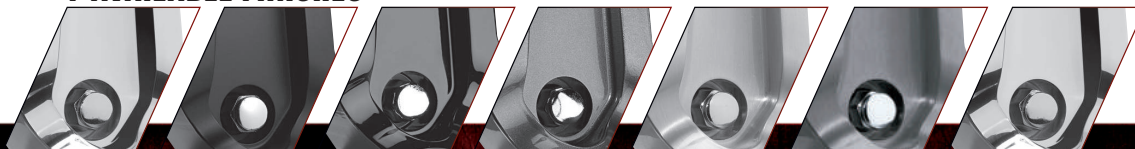

POLISHED

MATTE BLACK

GLOSS BLACK

GUNMETAL

CLEAR OVER  
FULL SATIN

BRUSHED SMOKE  
CLEAR

CLEAR OVER  
FULL POLISH



**Razor** in Concave Deep

18 • 19 • 20

Black Gloss Shown



**Razor** in Concave Shallow

18 • 19 • 20

Brushed Clear Gloss Shown

**BIG BRAKE READY**

Caliper Clearances  
Up to 1-3/4



BilletSpecialty **TOPLOADER**

18x8 from 20 lbs!



**Toploader** in Concave Deep  
18 • 19 • 20  
Matte Black Shown



**Toploader** in Concave Shallow  
18 • 19 • 20  
Polished Shown



**Wedge** in Concave Shallow  
18 • 19 • 20  
Gunmetal Gloss Shown



**Wedge** in Concave Deep  
18 • 19 • 20  
Black Matte Shown

**WEDGE**

18x8 from 21 lbs!

# PRO TOURING SERIES

## 6 Styles, Multiple Finish Options, Endless Possibilities

From Classic to Modern Muscle, the Pro-Touring Series is bred for high performance. Maximum dish to high offset applications, 4-piston disc to monster 6-piston brakes – everything you've done to turn your car into a corner carving machine is welcome here. Choose from the industry's best polished finish or from the custom powder coat options available to achieve your own look.

### Select From 7 AVAILABLE FINISHES

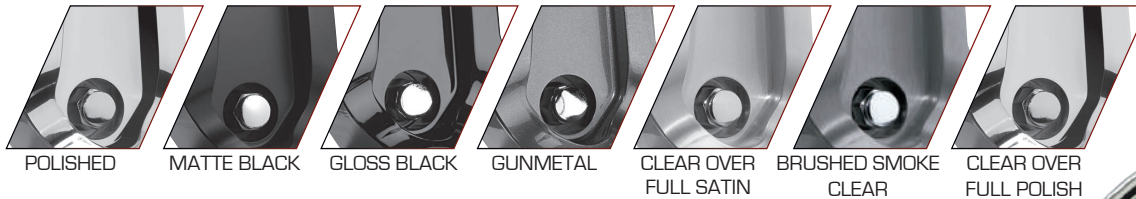

## BIG BRAKE READY



### G-Spec

18 • 19 • 20

Gunmetal Gloss Shown



### Daytona

18 • 19 • 20

Polished Shown



### Gran Prix

18 • 19 • 20

Gunmetal Gloss Shown





**65 Nova**  
Driven By:  
Al & Robby Unser



**Laguna**  
18 • 19 • 20  
Matte Black Shown



**Gran Sport**  
18 • 19 • 20  
Brushed Clear Glass Shown



**Sebring**  
18 • 19 • 20  
Black Gloss Shown

# PROFILE COLLECTION

## If You Could Have Any Wheel in the World...

Billet Specialties is in the business of being the best. Period. The Profile Collection is designed for discriminating enthusiasts that demand the best wheel available be featured on their car. The smooth sweeping curves and dramatic features of these wheels are the product of millions of lines of machining code executed on state-of-the-art CNC machines.



**Stiletto**

17 • 18 • 20 • 22

Available in 6-lug @ [billetspecialties.com](http://billetspecialties.com)



**Fuelie**

17 • 18 • 20 • 22



**Hiboy**

17 • 18 • 20 • 22



**Flare**  
17 • 18 • 20 • 22



**Rail**  
17 • 18 • 20 • 22  
Available in 6-lug @ [billetspecialties.com](http://billetspecialties.com)



**Velocity**  
17 • 18 • 20 • 22



**Rat Tail**  
17 • 18 • 20 • 22  
Available in 6-lug @ [billetspecialties.com](http://billetspecialties.com)

# VINTAGE SERIES

## The Perfect Interface between Paint and Asphalt.....

Billet Specialties Vintage inspired Knuckle and Grinder wheels reset the bar in hot rod wheel design. Three distinctive profiles are available to help achieve that perfect look and stance. Each wheel is precision machined and finished to your preference. Get a set for your Hot Rod now and be ready for the crowds!

### 3 FINISH OPTIONS



POLISHED

BRUSHED CLEAR

SMOKE

### 3 PROFILE OPTIONS

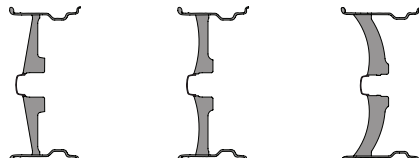

Standard

Dish

Extreme Dish

# KNUCKLE



**Knuckle Extreme**  
20" Only

Knuckle Extreme C Shown



**Knuckle**

18 • 19 • 20

Knuckle Polished Shown



**Knuckle Dish**

18 • 19 • 20

Knuckle Dish S Shown

As Featured on Randy Wilcox's 62 Bubble  
• 2015 Barret Jackson Cup Winner  
• 2015 Street Machine of the year Finalist

Built By:  **AUTOROTIVE CREATIONS**



# ***GRINDER***



**Grinder**  
18 • 19 • 20  
Grinder C Shown



**Grinder Dish**  
18 • 19 • 20  
Grinder Dish Polished Shown



**Grinder Extreme**  
20" Only  
Grinder Extreme S Shown

# VINTAGE SERIES

## The Finest Styling in History

Wheels that have defined hot rodding through the years are mixed with new styles that look like they've always been there. Custom built to fit your hot rod, get your own piece of nostalgia in today's high profile diameters. Each wheel is precision machined with multi-axis technology and hand finished to an unrivaled polished or powder coated finish. Hex and spinner cap options are available on select styles.



**Bonneville G**  
17 • 18 • 19 • 20 • 22



**Bonneville C**  
17 • 18 • 19 • 20 • 22



**Bonneville S**  
17 • 18 • 19 • 20 • 22



**Bonneville**  
17 • 18 • 19 • 20 • 22



**BIG BRAKE READY**



**Heritage S**  
17 • 18 • 19 • 20 • 22



**Heritage G**  
17 • 18 • 19 • 20 • 22



**Heritage**  
17 • 18 • 19 • 20 • 22



**Heritage C**  
17 • 18 • 19 • 20 • 22

# VINTAGE SERIES

The Sprint wheel draws on the past to remain timeless going forward. Modern trends meld with vintage styling to create wheels that will be as stunning ten years from now as they are today. To create the staggered Hot Rod look, we suggest you select the Concave Shallow profile for the front and the Concave Deep profile for the rear wheels. Select our award winning polished finish or one of two powder coat finishes to further enhance your vehicle.

## BIG BRAKE READY

Caliper Clearances  
Up to 1-13/16



## SPRINT CONCAVE SHALLOW



Select Concave Shallow  
for the front and Concave  
Deep in the rear for the  
Ultimate Stagger & Stance!



Sprint Polished  
18 • 19 • 20  
In Concave Shallow



Sprint C  
18 • 19 • 20  
In Concave Shallow



Sprint S  
18 • 19 • 20  
In Concave Shallow





# ***SPRINT CONCAVE DEEP***



**Sprint C**  
18 • 19 • 20  
In Concave Deep



**Sprint S**  
18 • 19 • 20  
In Concave Deep



**Sprint Polished**  
18 • 19 • 20  
In Concave Deep

# VINTAGE SERIES



**Legacy 2 C**  
17 • 18 • 19 • 20 • 22  
Includes Spinner Cap



**Legacy 2 S**  
17 • 18 • 19 • 20 • 22  
Includes Spinner Cap



**Legacy 2**  
17 • 18 • 19 • 20 • 22  
Includes Spinner Cap



**Legacy 2 G**  
17 • 18 • 19 • 20 • 22  
Includes Spinner Cap



"We use only top notch components on our builds! Billet Specialties attention to detail and excellent customer service is why they are part of every Precision Hot Rod!"

- Dan Tesar & Larry Brunkala  
Precision Hot Rods & Fabrication

### **KNOCK-OFFS** FOR LEGACY & DRAGSTER WHEELS



HEX NUT



FLAT



DEEP



**Legacy G**  
15 • 16 • 17

3-Piece Knock-Offs Sold Separately



**Dragster**  
15 • 16 • 17

3-Piece Knock-Offs Sold Separately



**Legacy**  
15 • 16 • 17

3-Piece Knock-Offs Sold Separately

# VINTAGE SERIES



**GOODGUYS**

2014 GIVEAWAY CAR

'32 TRIBUTE

BY:



## LIMITED EDITION

ONLY 100 SETS TO BE MADE

GET A SET NOW BEFORE THEY ARE GONE!



Lobeck  
15 • 17



Altered  
15x4 • 15x6 • 18x4.5



Lobeck G  
15 • 17



Each Set Is Numbered



H.A. Bagdasarian Award  
World's Most Beautiful Custom Winner



**Santa Fe**  
15 • 17



**Dyno SL**  
17 • 18 • 20



**Dyno SLG**  
17 • 18 • 20



**Outlaw**  
15 • 17

# VINTEC SERIES

## They Just Look Great on Everything.

When we introduced the Vintec Series there was a resounding response that made it a legend in its own time. The timeless design of these 3 wheels have made their way to countless street rods, muscle cars and classic trucks all over the world. Available with our lug-covering hex cap (standard) or optional spinner cap upgrade.



**BIG BRAKE READY**



Vintec Dish  
15 • 17



SLD 89  
17 • 18 • 20 • 22  
Shown with optional Spinner Cap



Optional Spinner Cap Available

# CRUISE LINE

## Old School Learned Some New Tricks

The Cruise Line allows you to get creative while perfectly fitting the period styling of your car. Choose from traditional styles like the Chicayne & Classic or their more radical cousins the Hustler and Rebel. Styles are available from 15" all the way up to 20" for that amazing blend of modern design and nostalgia.



**Classic**  
15 • 17



**Chicayne**  
15 • 17



# SLC SERIES

## Unique Starts Here

The definition of insanity is to do the same thing over and over while expecting a different result. Take a detour from what you're used to. The SLC Series features wheels that tastefully depart from the ordinary and predictable to breathe some excitement into your ride. Select styles are available in five popular powdercoat finishes to further compliment your vehicle.

Select From  
**7 AVAILABLE FINISHES**

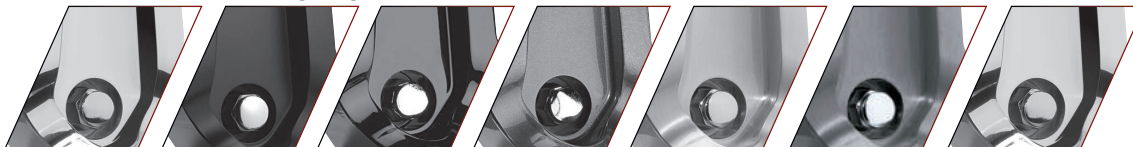

POLISHED

MATTE BLACK

GLOSS BLACK

GUNMETAL

CLEAR OVER  
FULL SATIN

CLEAR OVER  
POLISHED SATIN

CLEAR OVER  
FULL POLISH

## BIG BRAKE READY



**Turbine**

17 • 18 • 19 • 20 • 22

Clear Over Polished / Satin Finish Shown



**Turbine**

17 • 18 • 19 • 20 • 22

Clear Over Satin Finish Shown







**Fury Wheels**  
As featured on the  
2015 Street Rodder  
Road Tour Car.



**GTO**  
17 • 18 • 19 • 20 • 22  
Gunmetal Finish Shown



**GTO**  
17 • 18 • 19 • 20 • 22  
Full Polished Finish Shown



**Fury**  
17 • 18 • 19 • 20 • 22  
Full Polished Finish Shown

# SLC SERIES

In this collection, classic styles with a twist mix with modernistic designs that demand attention. The soft flowing detail of each spoke is a telltale sign that the SLC Series is so much more than the ordinary straight-cut billet wheel. Our attention to detail pays off in styling that screams excellence. Custom built just for you, these stunning wheels are ready for big brakes and are available in a wide range of diameters 17" to 24".



SLC62  
17 • 18 • 19 • 20 • 22 • 24



**BIG BRAKE READY**



SLC63  
20 • 22



SLC76  
20 • 22



SLC75  
17 • 18 • 20 • 22

# SLG SERIES



**SLG02**  
17 • 18 • 19 • 20 • 22 • 24  
Also Available in 6 Lug (SLG06)

## Straight Forward Style

Each wheel in the SLG series is a radical departure from the next. Soft Lip reverse rims give each style a striking long leg effect that delivers maximum visual impact as you roll up. Custom built to your specs and ready for big brakes, the SLG series can enhance the highest tech hot rod or muscle car.



**SLG45**  
17 • 18 • 19 • 20 • 22



**SLG05**  
17 • 18 • 19 • 20 • 22



**SLG60**  
17 • 18 • 20 • 22

# LEGENDS SERIES

## Find Your Hot Rod Mojo

Muscle cars, Street Rods & Classic Trucks — American machines that have become the canvas of hot rod artistry. The Legends Series takes the American Hot Rod seriously as one of the few cast wheel lines actually Made In America! We manufacture each cast center to precise detail in both strength and beauty and mate them to the same soft lip rims as our forged billet wheels. The result? Captivating designs with timeless features that are custom built to your specifications in 15" through 20" diameters.



**Mag**  
17 • 18 • 20



Bolt on Spinner Cap  
Available for Rival  
and Mag Wheels



**Mag S**  
17 • 18 • 20



**Mag B**  
17 • 18 • 20



**Mag G**  
17 • 18 • 20



**Rival**  
15 • 17



**Rival S**  
15 • 17



**Rival B**  
15 • 17



**Rival G**  
15 • 17



**Dagger S**  
17 • 18 • 20



**Dagger B**  
17 • 18 • 20



**Dagger G**  
17 • 18 • 20



**Dagger**  
17 • 18 • 20

# STREET SMART LINE

## Five Ways to Get "The Look" Without Breaking the Bank

Billet Specialties is the only company to offer genuine billet wheels at very attractive pricing. Choose from five awesome Street Smart styles that are bred for muscle cars and hot rods. These striking wheels are assembled to order to custom fit your car to your specs. True custom billet wheels, award-winning style, custom built at a great price... can it get any better?



**Challenger**  
15 • 17 • 18 • 20



**Street Star**  
15 • 17 • 18 • 20



**Qualifier**  
15 • 17 • 18 • 20



**Fast Lane**  
15 • 17 • 18 • 20



**Launch**  
17 • 18 • 20

# BLVD SERIES

Are BIG wheels your thing? Billet Specialties new BLVD Series has a wheel for you. Each design makes a bold statement of style that will separate your ride from the rest. Select from true directional designs as well bold traditional spoke styles. Step into some Big Billet Style Now!



**BLVD 81**  
20 • 22 • 24 • 26  
Available in 6 Lug  
Brushed Face Polished Accent Shown



**BLVD 82**  
20 • 22 • 24 • 26  
Polished Shown



**BLVD 63**  
20 • 22 • 24 • 26  
Polished Shown



**BLVD 83**  
20 • 22 • 24 • 26  
Brushed Face Polished Accent Shown



Select From  
**7 AVAILABLE FINISHES**



FULLY POLISHED   MATTE BLACK   GLOSS BLACK   GUNMETAL



CLEAR OVER FULL SATIN   CLEAR OVER FULL POLISHED   BRUSHED FACE POLISHED WINDOWS



**BLVD 65**  
20 • 22 • 24 • 26  
Full Polished Shown



**BLVD 85**  
20 • 22 • 24 • 26  
Brushed Face Polished Accent Shown



**BLVD 64**  
20 • 22 • 24 • 26  
Brushed Face Polished Accent Shown



**BLVD 84**  
20 • 22 • 24 • 26  
Brushed Face Polished Accent Shown

# GS SERIES

## Go Big or Go Home!

You want to live the dream? Part of you wants the biggest and part of you wants the best. Here are the biggest and the best in all their mirror-polished billet glory! Step all the way up to 26" with the most impactful designs on the planet.



**GS47**  
17 • 18 • 20 • 22 • 24 • 26



**GS51**  
24 • 26



**GS52**  
22 • 24 • 26



**GS08**  
17 • 18 • 20 • 22 • 24 • 26



**GS53**  
24 • 26



**GS68**  
20 • 22 • 24 • 26



**GS3D**  
24 • 26

# STREET LITE

## Built For Speed...

The Street Lite is more than an amazing looking wheel. It is designed to be the ultimate street and strip wheel. Carrying the hardcore SFI 15.1 certification, Street Lite wheels are a sign that you are serious about performance and uncompromising on style. This ultra-light weight wheel handles the everyday street with ease thanks to its rotary forged center structure. Available in 15" (SFI 15.1 approved) and 17"



**Street Lite**  
17x4.5"  
1pc. Forged Front Wheel  
Fully Polished or Hard Coat Black Anodized



**Street Lite**  
17x7 • 17x11  
Polished or Hard Coat Black Anodized Center



**Street Lite**  
15x3.5 • 15x15"  
15x10" F-Body Rear  
Polished or Hard Coat Black Anodized Center

Billet Specialties Sales Associate  
Kevin Andelbrat hangs the wheels  
on his Chevelle at Route 66 Raceway.



**Street Lite**  
15x10 - 7.5" Backspace  
'93 - '02 Camaro/Firebird  
'05 - '14 Mustang GT  
5x4.5 BC or 5x4.75 BC



**Street Lite**  
15x10 - 6.5" Backspace  
'79 - '93 Fox Body (No Brake Mods Required)  
'94 - '04 SN95  
5x4.5 BC



**Street Lite**  
17x10  
5x4.5", 5x4.75" 115mm, 5x120mm



**SPECIAL BARRELS ALLOW FOR  
EXTRA CLEARANCE FOR OEM BRAKES**



# STREET LITE - DOUBLE BEADLOCK

## **Built For Speed...**

The Street Lite is more than an amazing looking wheel. It is designed to be the ultimate street and strip wheel. Carrying the hardcore SFI 15.1 certification, Street Lite wheels are a sign that you are serious about performance and uncompromising on style. This ultra-light weight wheel handles the everyday street with ease thanks to its rotary forged center structure.

\*The Street Lite double beadlock features black anodized beadlock rings.



**Double Beadlock Street Lite**  
15x10 through 15x15  
Polished Center



**Double Beadlock Street Lite**  
15x10 through 15x15  
Hard Coat Black Anodized Center

**Derek Travis**  
Silver Unit Racing 86 Camaro



# STREET LITE - SINGLE BEADLOCK

Mark Carlyle's IPS Motorsports  
Record Setting Corvette



**Single Beadlock Street Lite**  
15x10 - 7.5" Backspace  
'93 - '02 Camaro/Firebird  
'05 - '14 Mustang GT  
5x4.5 BC or 5x4.75 BC  
Polished Center

Matching Front



**17" Street Lite**  
17x4.5 2" Backspace  
Fully Polished or Hard Coat Black Anodized



**SPECIAL BARRELS ALLOW FOR  
EXTRA CLEARANCE FOR OEM BRAKES**

**Single Beadlock Street Lite**  
15x10 - 6.5" Backspace  
'79 - '93 Fox Body  
'94 - '04 SN95  
5x4.5 BC  
Hard Coat Black Anodized Center



# COMP SERIES - SFI APPROVED



## Pro-Level Drag Race Wheels

The Comp Series is the real deal with rotary forged centers for incredible strength and precision CNC spun outer rims for unrivaled trueness. These outstanding racing wheels are among the lightest in the sport. The lightweight & scalloped double beadlocks feature an aggressively knurled inner surface to prevent tire slip. SFI 15.1 and 15.2 certified.



Spindle Mount  
15x3.5 • 17x2.125



Spindle Mount  
15x3.5 • 17x2.125



1PC. Bolt On  
15x3.5



1PC. Bolt On  
15x3.5

Kye Kelly's Shocker Camaro  
2 time Cash Days Winner







J.C. Beattie's  
ATI Racing Copo Camaro



**2PC. Bolt On**  
15x3.5

Polished or Hard Coat Black Anodized Center



**Double Beadlock Rear**  
15x10 • 15x15 • 16x16

Polished or Hard Coat Black Anodized Center



**Standard Rear**  
15x8 • 15x15 • 16x16

Polished or Hard Coat Black Anodized Center

# B FORGED

MODULAR PERFORMANCE WHEELS

## SL SERIES

Engineered and built with the same quality you have known for three decades. B-Forged is Billet Specialties premium 3pc wheel line for the Modern Muscle, Exotic, Luxury & Pro Touring markets.



**455 SL**  
19" - 24"  
• STEP LIP



**530 SL**  
19" - 24"  
• STEP LIP



**961 SL**  
19" - 24"  
• STEP LIP



**180 SL**  
19" - 24"  
• STEP LIP



26 CENTER FINISHES



22 OUTER RIM FINISHES

SL Series features Step Lip Rim Halves for a unique look that saves up to 10% in weight over a reverse style 3pc wheel.



**600 SL**  
19" - 24"  
• STEP LIP

### Features

- Multiple Finish Options for the Centers & Rim Halves
- Premium ARP Hardware
- Recessed Bolt Pads for Extreme Weight savings are Standard on every B-Forged Wheel
- Massive Caliper Clearance



Machined Bolt Pad is standard on all B-Forged wheels



**252 SL**  
19" - 24"  
• STEP LIP



**393 SL**  
19" - 24"  
• STEP LIP



**710 SL**  
19" - 24"  
• STEP LIP

# B FORGED

MODULAR PERFORMANCE WHEELS

## RL SERIES

Engineered and built with the same quality you have known for three decades. B-Forged is Billet Specialties premium 3pc wheel line for the Modern Muscle, Exotic, Luxury & Pro Touring markets.



**475 RL**  
18" - 22"  
• CONCAVE  
• CONCAVE DEEP



**820 RL**  
18" - 22"  
• CONCAVE  
• CONCAVE DEEP



**180 RL**  
18" - 22"  
• CONCAVE  
• CONCAVE DEEP



**280 RL**  
18" - 22"  
• CONCAVE  
• CONCAVE DEEP



26 CENTER FINISHES



22 OUTER RIM FINISHES

RL Series features Reverse Lip Rim Halves that allows a larger Center Diameter for Big Style and a Deep Barrel look.



**500 RL**  
18" - 22"  
• CONCAVE  
• CONCAVE DEEP



**600 RL**  
18" - 22"  
• CONCAVE  
• CONCAVE DEEP



**530 RL**  
18" - 22"  
• CONCAVE  
• CONCAVE DEEP



**450 RL**  
18" - 22"  
• CONCAVE  
• CONCAVE DEEP

# WHEEL ACCESSORIES

BilletSpecialties



**Chrome Valve Stems**  
Bolt-In  
#999900



**Bullet Center Caps**  
2-7/8" Dia. Only  
#999840



**Replacement Hex Cap Removal Wrench**  
#999500



**Replacement Dome Cap Removal Wrench**  
#999525



**Thin Wall Socket**  
#999910

## Wheel Spacers & Lug Nuts

Wheel spacers are precision machined from 6061-T6 aluminum to ensure trueness, quality & strength. To ensure proper fitment you will need to measure the overall diameter of the bolt pad area of your wheels before ordering.

• Billet Specialties recommends the use of E-T style lug nuts for proper thread engagement. E-T lug nuts allow for an extra 1/4" of thread engagement.

### ALL WHEEL SPACERS HAVE A 3.080" CENTER BORE



**Street Lite Wheel Spacers**  
Not for use with 5/8" race type studs

**Wheel Size**  
15x3.5 Thru 15x10  
15x3.5 Thru 15x10

**Bolt Pattern**  
5x4.5 & 5x4.75  
5x4.5 & 5x4.75

**Spacer Size (in.)**    **Part Number**  
1/4 (.25)                WS3085625  
1/2 (.50)                WS3085650



**Wheel Spacers for Billet Specialties Brand Only**  
Fits directly to bolt pad for seamless appearance

**Bolt Pad Diameter (in.)**  
6-3/8 (6.375)  
6-3/8 (6.375)  
6-3/4 (6.75)  
6-3/4 (6.75)

**Bolt Pattern**  
5x4.5 & 5x4.75  
5x4.5 & 5x4.75  
5x4.5 & 5x4.75  
5x4.5 & 5x4.75

**Spacer Size (in.)**    **Part Number**  
1/4 (.25)                WS3086325  
1/2 (.50)                WS3086350  
1/4 (.25)                WS3086725  
1/2 (.50)                WS3086750



**Universal Wheel Spacers**  
For Non-Billet Specialties brand wheels

**Bolt Pattern**  
5x4.25, 5x4.50, 5x4.75, 5x5  
5x4.25, 5x4.50, 5x4.75, 5x5  
5x4.25, 5x4.50, 5x4.75, 5x5  
5x4.25, 5x4.50, 5x4.75, 5x5

**Spacer Size (in.)**    **Part Number**  
1/4 (.25)                WSG5L250  
3/8 (.375)              WSG5L375  
1/2 (.50)                WSG5L500  
3/4 (.75)                WSG5L750

The minimum thread engagement for each lug nut is equal to the diameter of the stud being used.

**Example:** 1/2" diameter stud - minimum thread engagement is 1/2" of stud length. E-T Lugs allow for an extra 1/4" thread engagement.



**E-T Conical Seat - OPEN END**  
Part #    Size  
999980    7/16-20    E-T  
999984    1/2-20     E-T  
999988    12mm-1.5   E-T



**E-T Conical Seat - CLOSED END**  
Part #    Size  
999970    7/16-20    E-T  
999974    1/2-20     E-T  
999978    12mm-1.5   E-T



**Acorn Bulge Seat - CLOSED END**  
Part #    Size  
LN71620    7/16-20  
LN1220    1/2-20  
LN1215    12mm-1.5  
LN1415    14mm-1.5



**Duplex Acorn Bulge Seat - CLOSED END**  
Part #    Size  
LN81415    14mm-1.5   Long Stud



**Mag Shank - Street Lite, RT, Performer (CLOSED END)**  
Part #    Size    Length  
999962    12mm-1.5   3/4"  
999963    12mm-1.5   1/2"  
999990    7/16-20    3/4"  
999991    7/16-20    1/2"  
999994    1/2-20     3/4"  
999995    1/2-20     1/2"



**Spline Drive - CLOSED END [Socket Key Included]**  
Part #    Size  
LNSD716    7/16-20    Spline Drive  
LNSD12    1/2-20     Spline Drive



**Wheel Stud Spacers**  
Part #    Size  
999495    .625" Tall    5/8" Stud  
999496    .825" Tall    5/8" Stud  
999497    1.125" Tall   5/8" Stud



**Mag Shank - Street Lite, RT, Performer (OPEN END)**  
Part #    Size    Length  
999964    12mm-1.5   3/4"  
999965    12mm-1.5   1/2"  
999992    7/16-20    3/4"  
999993    7/16-20    1/2"  
999996    1/2-20     3/4"  
999997    1/2-20     1/2"

\*1/2" long mag shank lug nuts for use with 15x3.5 & 15x4 wheels with 2.25" backspace only.

## WHEEL MEASURING INFORMATION

The following information can be used to gather measurements to ensure a proper fit for most applications.

### TORQUE SPECIFICATIONS

Stud Size	Torque Rating	Stud Size	Torque Rating
7/16"	70-80 ft.lbs.	10mm	45-55 ft.lbs.
1/2"	75-85 ft.lbs.	12mm	75-85 ft.lbs.
9/16"	100-115 ft.lbs.	14mm	85-95 ft.lbs.
5/8"	125-135 ft.lbs.	16mm	125-150 ft.lbs.

### MEASURING BOLT PATTERN

5 LUG

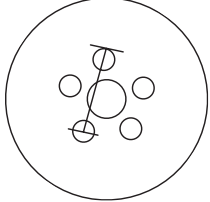

From back side of the top stud to the center of the top stud to the center of the second stud.

6 LUG

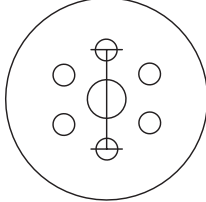

From center of the top stud to center of the second stud directly across.

8 LUG

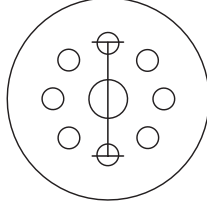

**IMPORTANT:** Overall wheel width is 1" wider than the listed size. For example a 17x8 wheel actually measures 9" wide overall. You must consider this when fitting your vehicle.

