

CHAMPIONSHIP



**DAIRI**

ENGINE COMPONENTS

EST. 1981

**2019** PERFORMANCE PARTS CATALOG



## DART MACHINERY

Many of America's most successful companies can trace their roots to basements, tool sheds and spare bedrooms. Like Hewlett Packard, Boeing, and Apple Computer, Dart Machinery began in humble surroundings. Richard Maskin founded Dart in 1981 in a two-car garage in Oak Park, Michigan. In the years since Maskin started his business with a desk and a telephone, Dart has become the proven leader in aftermarket cylinder heads, intake manifolds and engine blocks.

Maskin is well known to drag racing fans as a mechanical mastermind whose engines have won multiple NHRA Pro Stock world championships and dozens of national events. Like many successful entrepreneurs, Maskin turned his passion for drag racing into a thriving enterprise. The seeds were planted when Maskin competed with a variety of drag racing machines ranging from Modified Production Camaros to Pro Stock Gremlins. He developed raised intake runners, offset pushrods, and sheet metal intake manifolds for his innovative Pro Stock engines in the mid-'70s. These breakthroughs were quickly imitated by rival racers. Eventually, Maskin learned how to produce complete cylinder heads from scratch. This hands-on experience laid the foundation for Dart Machinery.



RICHARD MASKIN

The company's first products were Aluminum Hemi cylinder heads that dominated the Top Fuel and Funny Car categories. These purpose-built heads provided the power that ultimately broke drag racing's 300 mph barrier and produced the first 4.0-second Funny Car elapsed time. Maskin's Pro Stock roots were evident in the Race Series heads for big block Chevrolet V8s that soon followed. In recent years, Dart's spread port Big Chief heads have set the standard in classes ranging from Pro Street to Pro Mod. This tradition of innovation continued with the introduction of affordable Iron Eagle and PRO1 cylinder heads for small block and big block Chevy V8s, followed by Cast Aluminum and Iron engine blocks designed to meet the specialized needs of racers and performance enthusiasts. The company has since expanded its product line to include small block Ford and Honda components.

Dart is committed to producing the best engine components available. All development, machining and assembly are done at Dart's own facilities in order to maintain the highest standards of quality. State-of-the-art CNC machining centers, a computer controlled dynamometer and the proprietary "Speed Flow" technology/wet flow bench are among the assets that contribute to "the Dart advantage".

Maskin keeps current with the continuous advances in racing technology through Dart's engine development program. "Our engine program and our daily interaction with leading engine builders and winning racers keeps Dart on the leading edge of technology," Maskin explains. "We apply everything we learn to produce more powerful and more reliable parts for Dart customers."

Dart Machinery's Technology Center in Troy, Michigan, houses the company's administrative offices and R&D headquarters. The immense CNC machining centers that produce Dart heads and blocks from raw castings along with inspection, machining and warehouse operations are located in a separate manufacturing facility in nearby Warren, Michigan.

Dart Machinery was started with a desk, a telephone, and a dream. Today, Dart is the acknowledged leader in producing championship engine components.





# TABLE OF CONTENTS

ITEM	PAGE	ITEM	PAGE	ITEM	PAGE
<b>GENERAL INFORMATION</b>					
Research and Development	2-3				
Manufacturing Quality	4-5				
Casting and Metallurgy	6-7				
Important Features of Dart Heads	8				
CNC Porting and Head Options	9				
Important Features of Dart Blocks	10				
Custom Block Machining Options	11				
<b>SMALL BLOCK CHEVY</b>					
SHP Short Blocks	12				
SBC Top End Kits	13				
SHP Blocks	14				
SHP PRO Blocks	15				
Little M 305 Water Blocks	16				
Little M Sportsman Blocks	17				
Little M Blocks	18				
Iron Eagle Blocks	19				
Iron Eagle 4.500" B/S Blocks	20				
Race Series Aluminum Blocks	21				
Race Series Aluminum 4.500" Blocks	22				
Iron Eagle 23° 165cc S/S Heads	23				
Iron Eagle 23° 170cc S/S Vortec Heads	24				
Iron Eagle 23° 180cc Heads	25				
Iron Eagle 23° 200cc Heads	26				
Iron Eagle 23° 215cc Heads	27				
Iron Eagle 23° 230cc Heads	28				
Iron Eagle 23° 227cc CNC Heads	29				
SHP 23° 180cc Heads	30				
SHP 23° 200cc Heads	31				
SHP 23° 220cc Heads	32				
PRO1 23° 180cc Heads	33				
PRO1 23° 200cc Heads	34				
PRO1 23° 215cc Heads	35				
PRO1 23° 230cc Heads	36				
PRO1 23° 227cc CNC Heads	37				
PRO1 23° 245cc CNC Heads	38				
PRO1 23° LT1/LT4 Heads	39				
PRO1 18° 245cc Heads	40				
Race Series 18° 250-272cc CNC Heads	41				
Race Series 16° 268cc CNC Heads	42				
Race Series 15° 284cc CNC Heads	43				
Race Series 12.5° 265cc CNC Heads (Oval)	44				
Race Series 12.5° 296cc CNC Heads	45				
Race Series 11° Little Chief CNC Heads	46				
Race Series 9° Castings	47				
SBC Intake Manifolds	48				
SBC Accessories	49				
<b>GEN III LS NEXT</b>					
SHP LS Next Short Blocks	50				
SHP LS Next Blocks (Skirted)	51				
SHP LS Next PRO Blocks (Skirted)	52				
LS Next Blocks	53				
LS Next Aluminum Blocks (Skirted)	54				
LS Next Aluminum Blocks	55				
LS Next <sup>2</sup> Blocks (Upgrade)	56				
PRO1 LS 15° 205cc Heads (LS1 Compatible)	57				
PRO1 LS 15° 225cc Heads (LS1 Compatible)	58				
PRO1 LS 15° 250cc CNC Heads (LS1 Compatible)	59				
PRO1 LS 15° 280cc Heads (LS3 Compatible)	60				
PRO1 LS 12° 285cc CNC Heads (LS7 Compatible)	61				
Race Series LS 10° 368cc CNC Heads	62				
LS Manifolds	63				
LS Next Accessories	64				
<b>BIG BLOCK CHEVY</b>					
BBC Top End Kits	65				
Big M (MK IV, Gen V and Gen VI) Blocks	66				
Big M Gen VII (8.1/8.8L) Blocks	67				
Big M Sportsman Blocks	68				
Big M PRO Blocks	69				
Big M Aluminum Blocks	70				
Big M Race Series Aluminum Blocks	71				
Iron Eagle 24° 308/345cc Heads	72				
Iron Eagle 24° 330/365cc CNC Heads	73				
Iron Eagle 24° 320cc Gen VII (8.1L) Heads	74				
PRO1 24° 275cc Heads (Oval)	75				
PRO1 24° 310cc Heads	76				
PRO1 24° 325cc Heads	77				
PRO1 24° 345cc Heads	78				
PRO1 24° 525 MMR Heads (Marine)	79				
PRO1 24° 335cc CNC Heads	80				
PRO1 24° 355cc CNC Heads	81				
PRO1 24° 365cc CNC Heads	82				
PRO1 20° 440cc Heads	83				
PRO1 20° 451cc CNC Heads	84				
PRO2 24° 380cc CNC Heads	85				
Race Series 24° 340/370cc Heads (Oval)	86				
Race Series 18° 330/383cc Heads	87				
Big Chief PRO1 18°/14° 424cc Heads	88				
Big Chief 18° 424cc/14° 440cc CNC Heads	89				
Big Chief 14° 433cc CNC Heads (Oval)	90				
Big Chief II 11° 555cc CNC	91				
Big Chief 14° 505cc 5.000"	92				
BBC Intake Manifolds	93				
BBC Accessories	94				
<b>SMALL BLOCK FORD</b>					
SHP Short Blocks	95				
SBF Top End Kits	96				
SHP Blocks	97				
Sportsman Blocks	98				
Iron Eagle Blocks	99				
Iron Eagle PRO Blocks	100				
Race Series Aluminum Blocks	101				
Iron Eagle 20° 180cc Heads	102				
Iron Eagle 20° 200cc Heads	103				
Iron Eagle 20° 215cc Heads	104				
PRO1 20° 170cc Heads	105				
PRO1 20° 195cc Heads	106				
PRO1 20° 210cc CNC Heads	107				
PRO1 20° 225cc CNC Heads	108				
SBF Manifolds	109				
SBF Accessories	110				
<b>HONDA</b>					
Honda B-20 Series Blocks	111				
<b>BILLET BLOCKS AND HEADS</b>					
Custom Billet Blocks and Heads	112-113				
<b>ACCESSORIES AND SERVICE PARTS</b>					
Accessories and Service Parts	114-123				

## LEGAL NOTICES

**EMISSIONS NOTICE:** Dart components are not intended for sale or use in connection with pollution controlled motor vehicles. **SPECIFICATIONS:** We are committed to continuously improving our products. We reserve the right to change specifications and to discontinue products without notice. We have made every effort to ensure the accuracy of this catalog; however, Dart is not responsible for typographical errors or omissions. **POLICIES AND WARRANTIES:** Please see inside back cover for important ordering, shipping, and warranty information. **TRADEMARKS:** PRO, PRO1, PRO2, PRO1 LS, Big M, Big M PRO, Big Chief, SHP, Little M, LS NEXT, Little Chief, Iron Eagle, Race Series, Iron Eagle PRO, SHP PRO are registered trademarks of Dart Machinery, Ltd. Chevrolet, Chevy, LS3, LS7, Dominator, Edelbrock, Ford, Holley, Honda, MAHLE and other trademarks used in this catalog are the property of their respective trademark holders and are used for identification purposes only. **COPYRIGHT:** © 2019, Dart Machinery, Ltd. All rights reserved.

# **DART** R&D

## RESEARCH & DEVELOPMENT.

**ADVANCED ENGINEERING MEANS UNDERSTANDING EVERY ASPECT OF A DESIGN.**

When testing and designing components for an internal combustion engine, every piece of data that's missing might be a breakthrough that gets left on the table. That is why it is important to ensure that your research equipment is capable of capturing the bigger picture.

Dart's custom built wet flow bench was created for exactly this reason. Along with high-tech digital design and testing on a traditional flow bench, in the dyno cell and on the race track, Dart's research and development process makes use of our state of the art equipment to get the most complete data possible to produce maximum engine strength and performance.

It is often said that an engine is an air pump, but in fact an engine also moves a considerable volume of fuel through its induction system and cylinders. After all, it is the fuel that contains the energy that drives the car. Burning more fuel produces more power, provided that combustion efficiency is maintained. Unfortunately, a bench that only measures dry airflow can't simulate this crucial characteristic of a running engine.

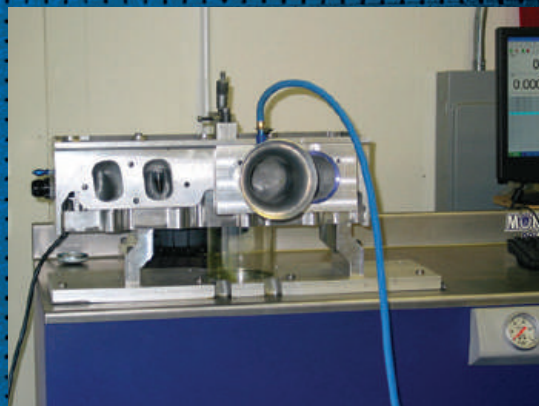

The computer on the wet flow bench captures data about airflow, fuel consumption and air/fuel ratios.



Dart's proprietary wet flow bench can flow 800cfm - with fuel in the mixture, and operates at 55 inches of depression rather than the 28 inches which is commonly used for testing dry flow. This more closely replicates the conditions present in an actual racing engine.



# RESEARCH & DEVELOPMENT

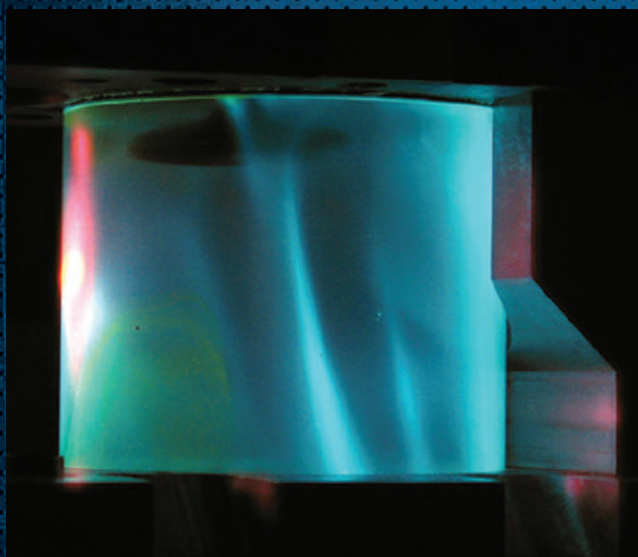

A clear cylinder sleeve allows technicians to observe the physical behavior of the air/fuel mixture entering the chamber.

Dart's wet flow bench uses a testing liquid with the same specific gravity as gasoline, which has been laced with a fluorescent dye, allowing researchers to observe the behavior of the fuel as it flows through the head. In this manner, our head designers can see what designs encourage proper fuel atomization and avoid designs that cause fuel to congeal into solid streams or become overly turbulent.

Wet flow has shown us some of the key design principles that optimize fuel behavior in a cylinder head. A port design that flows more fuel and air while remaining smaller will make more power. Sharp edges around the intake seats will shear the fuel flow and increase atomization, and thus, fuel flow. Through repeated trials Dart researchers have been able to collect hard data from the wet flow bench that has directly resulted in increased performance.

Like dry flow benches and dynos, the wet flow bench is another weapon in Dart's arsenal. The wet flow bench makes the formerly invisible movement of fuel and air readily apparent and it provides hard data on a cylinder head's ability to move fuel and air efficiently.



Traditional flow benches are still a useful tool in cylinder head development, but cannot provide any data regarding the fuel handling capabilities of a port or chamber design.



# MANUFACTURING QUALITY.

*EACH DART PRODUCT IS FOUNDED ON **STATE-OF-THE-ART** COMPUTER ASSISTED DESIGN AND **PREMIUM CASTINGS.***

Dart's machining and qualifying is designed to maintain the highest level of quality throughout manufacturing process. Our production facility runs 24 hours a day, 6 days a week. These top of the line machines are the same ones used by major automotive manufacturers as well as some in the aerospace industry. Each Dart component is thoroughly inspected to ensure that they are free of porosity and other defects.



Dart uses an advanced Zeiss coordinate measuring machine to ensure the utmost accuracy in each part produced. The Zeiss is capable of measuring hundreds of points along virtually any surface of a part. The CMM employs dynamic navigation software that compensates for the deflection that occurs as the passive scanning probe pushes against the surface of a component while in motion. This powerful machine gives us the ability to maintain exact tolerances and monitor our machining tools to prevent inaccuracies due to tool wear.

Dart makes use of highly advanced CNC technology for finish machining procedures and porting. Our 5-axis CNC machines craft blocks and heads with precision and detail.

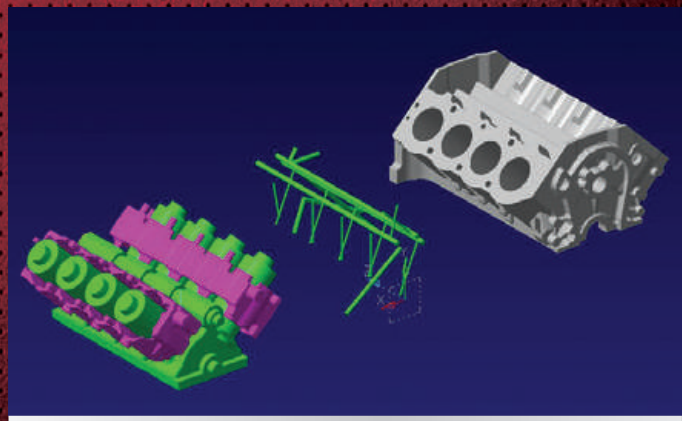



# MANUFACTURING QUALITY

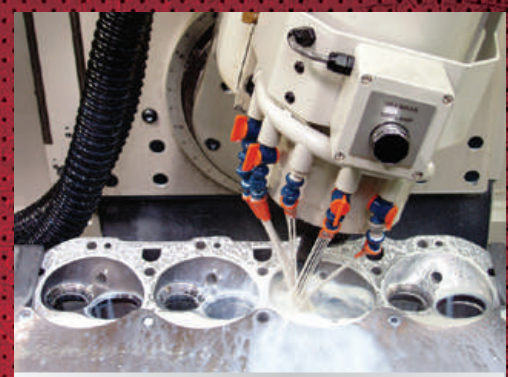
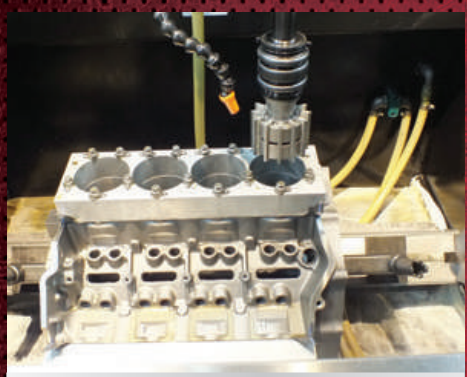

Our wide array of CNC equipment allows us to manufacture components with the highest level of finish in the industry, and even finished to your specifications on request. Dart also offers a full range of custom machining options for blocks and heads, available by special order.



Getting the best results requires the right tools for the job, so Dart employs an array of highly specialized machinery to optimize every process. Our Sunnen SV-20 CNC hone allows us to maintain extraordinary bore size accuracy and to carefully control the peaks and valleys of the bore, achieving the perfect hone in a fraction of the time.

There aren't any shortcuts when it comes to crafting the best performing, most reliable components around. At Dart, we believe that the formula is hard work, seasoned experience, and the best equipment money can buy.



# CASTING & METALLURGY.

***THE QUALITY, STRENGTH AND PERFORMANCE OF A CASTING DEFINE THE POTENTIAL OF THE FINAL PART.***

Castings made with mediocre materials will never be able to support the heat and power that a casting made from premium alloys will. Castings poured without the utmost attention to detail can suffer crippling structural flaws that lower the bar for the performance of the end product in ways that no amount of machining can alleviate.

Because it's important to build on a solid foundation, Dart takes the casting process very seriously. Every single Dart casting is 100% made in the United States from start to finish. Many of our Aluminum castings employ aerospace quality alloy, the best in the industry for the high temperature, high pressure demands of performance engine operation. Our Iron castings use a selection of premium alloys, carefully chosen to meet the needs of each of our product lines. These Iron alloys offer excellent tensile strengths and Brinell hardness ratings from 200 to 250 or more, well above that of a "bargain" casting. This translates to blocks and heads that have longer life spans and can be built to more demanding specifications.

In addition to our regular premium alloys, Dart also offers our Iron components cast from special Compacted Graphite Iron (CGI). Compacted Graphite Iron looks just like regular Cast Iron, and weighs about the same, however the alloy is 100% stronger. This greatly increased strength makes CGI parts suitable for the most demanding, high stress engine applications like turbo, supercharged or nitrous engines that will run with extreme cylinder pressures.

Top grade alloys are just one piece of the puzzle. Dart also works closely with our American foundries to ensure that the casting process has been perfected to an art. Everything from the pouring process, to the temperature the molten metal reaches before pouring, to the heat treatment procedure can have a dramatic impact on the final quality of the casting. Even small oversights can lead to components that suffer from porosity, often completely invisible to the naked eye,



United States tier two foundries have extensive experience with automotive requirements and practices, and have served the American auto industry for many decades.



All of Dart's castings are produced at foundries in the Midwest United States, within six hours driving time of our Detroit area headquarters and manufacturing facility.





# CASTING & METALLURGY



Dart maintains a large inventory of raw castings which must be ordered months in advance in order to keep our production and delivery times on a tight schedule.

which can weaken the integrity of the entire block or head. Dart metallurgists confer with experts at our partner foundries on a regular basis to ensure that every step of the casting process is carefully observed and controlled.

Casting design also factors heavily into the quality of the final product. Dart's R&D (Research & Development) department is involved in casting design from the earliest stages. Dart components use "chills", special metal inserts into the casting mold which cool the metal at a different rate in the area around them as it is being poured. This allows us to control more than just the final shape of the part and quality of the alloy. It allows us to increase the final density of the metal in the specific areas that need it most. Techniques like this allow us ultimate control over the final casting.

With the quality, strength and performance of Dart castings, you can be assured that you're getting the best components money can buy.



# IMPORTANT FEATURES OF DART HEADS



## 345cc

CYLINDER HEAD EXAMPLE



Raised and machined valve cover rails help to contain oil and increase valve cover rocker arm clearance.

Rolled valve angles on many style heads provide smaller chambers and improved airflow.

Precision as cast ports and chambers give you ported style performance at a fraction of the cost.

Choices in intake runner volumes are available to suit your performance requirements.

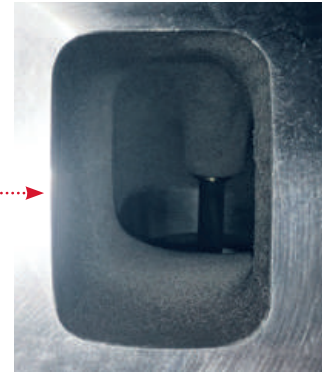

CNC porting options provide outstanding accuracy and consistency.

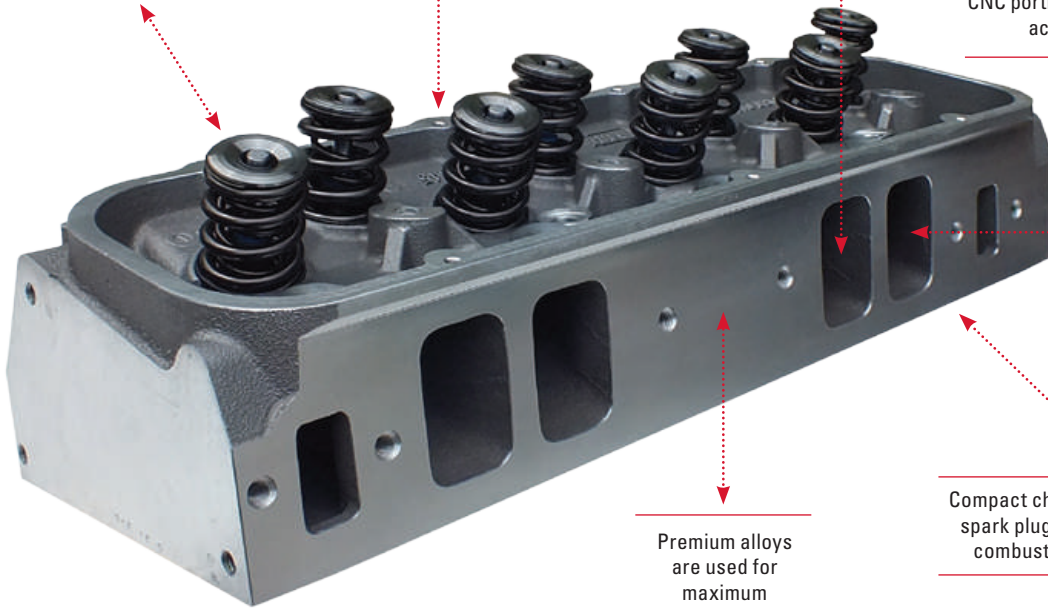

Premium alloys are used for maximum strength and durability.

Compact chambers with relocated spark plugs to promote efficient combustion and flame travel.

Big block heads have provision for extra head studs in valley area.

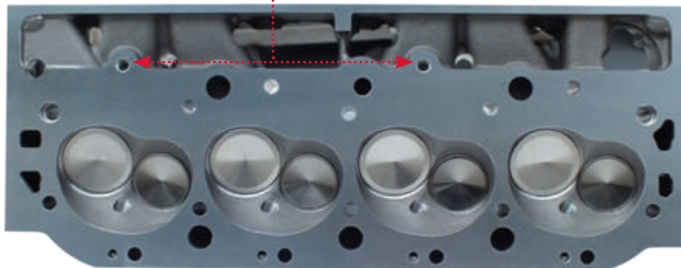

# CNC PORTING & CYLINDER HEAD OPTIONS

AS CAST



Dart can provide **CUSTOM MACHINED** and **ASSEMBLED** cylinder heads to meet your needs.

Now you can get Dart Race Series small block and big block cylinder heads prepared to your exact requirements! We've expanded our range of CNC porting and component options to fit more applications and budgets.

FULL PORT INTAKE



FULL PORT EXHAUST



**AS CAST:**

Dart Iron Eagle and PRO1 heads have intake ports, exhaust ports and combustion chambers which are designed to be used as is. They are cast based on hand developed models to deliver excellent performance without requiring any additional porting or grinding.

**FULL PORT:**

Full CNC machining of intake ports, exhaust ports, and combustion chambers for maximum power and consistency. Includes precision valve job and hand blending.

CNC CHAMBER



COPPER VALVE SEATS



**NITROUS & CONICAL CHAMBER OPTIONS:**

Dart's conical chamber machining helps to extract maximum performance from nitrous and forced induction engines.

**VALVE SEAT OPTIONS:**

Powder metal, Ductile Iron and Copper infiltrated seats are standard in most Dart heads. Copper and hardened seat options are available.

TITANIUM VALVES



MANGANESE-BRONZE GUIDES



**VALVE MATERIAL OPTIONS:**

Premium Stainless Steel valves are standard in Dart cylinder heads. Titanium and Inconel are an available option. Inconel valves are recommended for marine or turbocharged applications.

**VALVE GUIDES:**

Dart manufactures our own valve guides from premium Manganese & Nickel Bronze for improved wear characteristics and precise tolerances.

# IMPORTANT FEATURES OF DART BLOCKS

## Dart blocks are loaded with features you won't find in any factory casting.

Working with top racers and engine builders, we've designed blocks to solve the problems of production-type blocks used in high performance and competition applications.

Premium alloys, extra thick decks, siamese bores, enlarged water jackets, priority main oiling, 4-bolt main caps, finished main bearing bores and cam tunnels, honed lifter bores and coated cam bearings make it easier to build superior racing and performance engines.

Blocks are machined in-house on precision CNC equipment to ensure quality and to eliminate the need for expensive blueprinting.

Every machining operation on every Dart block is documented for future reference.

Aluminum blocks use Ductile Iron sleeves and extra thick cylinder walls.

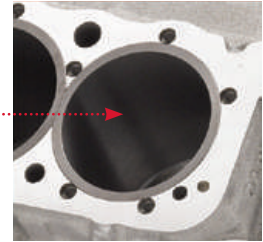

Siamese cylinders with extra thick walls provide superior ring seal, and resist cracking. Enlarged water jackets improve cooling.



Blind head bolts don't go through to water.



Priority main oiling system delivers oil to the critical main bearings first for reliable high RPM lubrication.

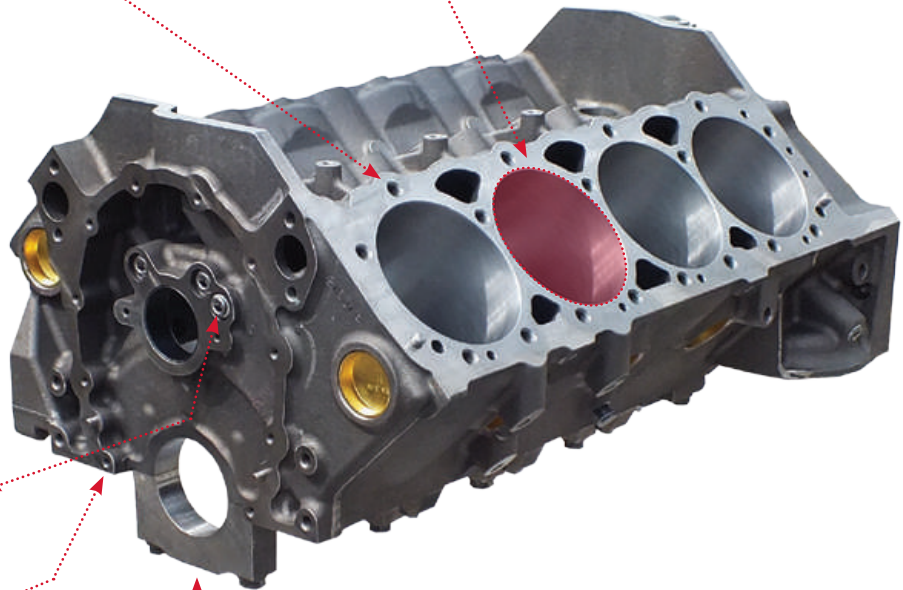

Splayed outer bolts on the main bearing caps are secured into the strongest part of the main webs.



Ductile Iron or billet steel main caps with splayed outer bolts for maximum strength.

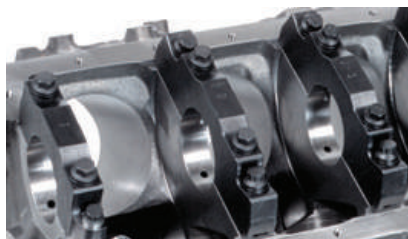

Big blocks have provision for extra head studs in valley.



# CUSTOM BLOCK MACHINING OPTIONS

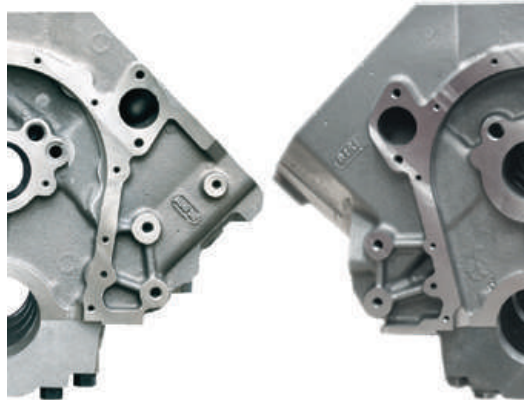

**Dart can fulfill VIRTUALLY ALL custom block machining needs.**

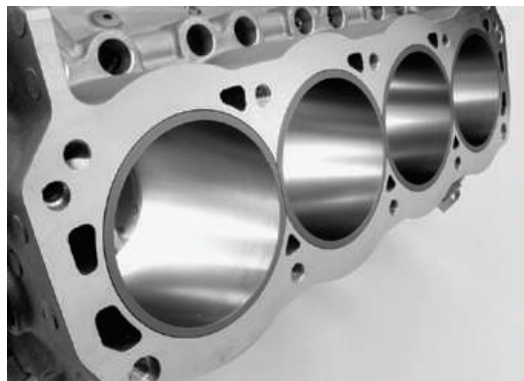

**CUSTOM DECK HEIGHTS:**

Decks can be ordered milled to your specification for custom applications.

**CUSTOM BORE SIZES:**

Order your cylinder bores in the sizes you need right from Dart. Final hone is required to finish.

**CAM BORE RESIZING:**

Available cam upgrades include 50mm Roller, 55mm Roller, 54 Babbitt (2.125), 55mm Babbitt, 60mm Roller & 60mm Babbitt and other options.

**LIFTER BORE RESIZING:**

Lifter bores can be ordered resized for oversize and special lifter diameters.

**BRONZE LIFTER BUSHINGS:**

Bronze bushed lifter bores for .842", .874", .904" and .937" lifters. We also have keyed lifter bushings available.

**LIFTER RELOCATING:**

We can supply blocks with altered lifter locations for exotic cylinder head applications.



**BLOCK LIGHTENING:**

Dart has CNC lightening programs which are designed to preserve the integrity of the block, so that weight can be removed without loss of strength in critical areas. We can also lighten main caps.

**STROKE CLEARANCE:**

We offer stroke clearance programs for most Dart blocks and accommodate most rotating assemblies. Please call a sales associate today for program information and qualification of your components.

**MAIN STUD KITS:**

Blocks with standard main cap bolts (Little M, Big M and Ford Iron blocks) can be ordered with main cap studs.



**PISTON OIL SQUIRTERS:**

Keeping the pistons cool is one of the keys to reliability in endurance racing engines. Spraying the underside of the piston top with a jet of pressurized oil can help to prevent piston failure in oval track, marine, and heavy duty applications.

**BLOCK PREP:**

Dart can finish hone and deck, install cam bearings, freeze plugs, pipe plugs, wash and bag your block so it is ready for assembly when you receive it. Requires customer supplied specifications.





# SMALL BLOCK CHEVY SHORT BLOCKS

## QUICK INFO >>>

Professionally built short blocks with brand new premium components. Street performance and Sportsman racing.

## 372, 400 & 427 CUBIC INCHES

Simplify engine building and save time with pre-engineered, dyno tested short block combinations from Dart's SHP (Special High Performance) group.

These quality component packages are designed to allow the user to build more powerful and durable engines at a very affordable cost.

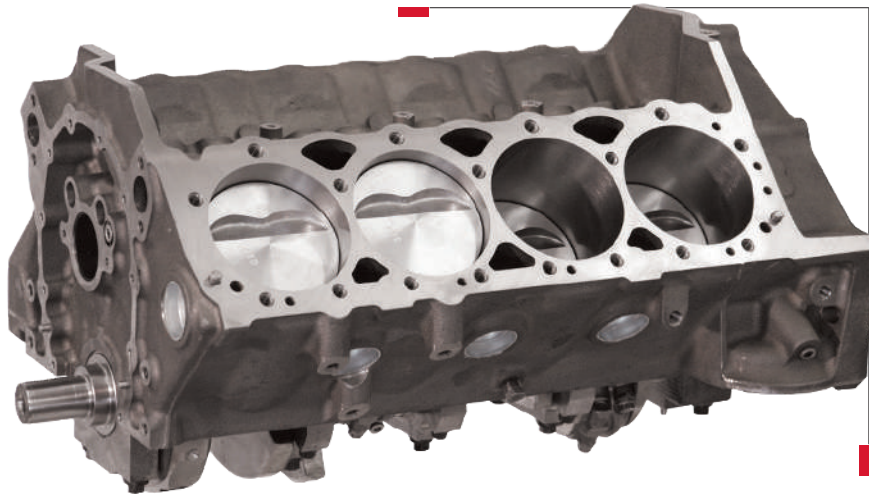

Top off your Dart short block with one of our performance matched top end kits for a great performing engine at an affordable price.

### 372 CUBIC INCH SHORT BLOCK

Internally Balanced  
Special High Performance Dart Block (SHP)  
4.125" Bore x 3.480" Stroke  
Plate Honed Cylinders  
Cast Steel Crankshaft  
Forged 4340 I-Beam Rods w/ 3/8" Cap Screws  
Hypereutectic Flat Top Pistons w/ Full Floating Pin  
Hastings Moly Rings  
Clevite Bearings  
Coated Cam Bearings

**Upgrades Available: Forged 4340 Crank, H-Beam Rods w/ 7/16" ARP 2000 Bolts & Forged Pistons.**

**CR 9.9:1 w/64cc chamber & .041" gasket.**

**CR 9.1:1 w/72cc chamber & .041" gasket.**

**Upgrade available to Little M or SBC Race Series Aluminum blocks.**

### 400 CUBIC INCH SHORT BLOCK

Internally Balanced  
Special High Performance Dart Block (SHP)  
4.125" Bore x 3.750" Stroke  
Plate Honed Cylinders  
Cast Steel Crankshaft  
Forged 4340 I-Beam Rods w/ 3/8" Cap Screws  
Hypereutectic Flat Top Pistons w/ Full Floating Pin  
Hastings Moly Rings  
Clevite Bearings  
Coated Cam Bearings

**Upgrades Available: Forged 4340 Crank, H-Beam Rods w/ 7/16" ARP 2000 Bolts & Forged Pistons.**

**CR 10.8:1 w/64cc chamber & .041" gasket.**

**CR 10:1 w/72cc chamber & .041" gasket.**

**Upgrade available to Little M or SBC Race Series Aluminum blocks.**

### 427 CUBIC INCH SHORT BLOCK

Internally Balanced  
Special High Performance Dart Block (SHP)  
4.125" Bore x 4.000" Stroke  
Plate Honed Cylinders  
Forged 4340 Steel Crankshaft  
Forged 4340 H-Beam Rods - 7/16" ARP 2000 Bolts  
Forged Flat Top Pistons w/ Full Floating Pin  
MAHLE Rings  
Clevite Bearings  
Coated Cam Bearings

**Options Available: 20cc Dished Pistons. Reduce CR by 1.2.**

**CR 11.4:1 w/64cc chamber & .041" gasket.**

**CR 10.5:1 w/72cc chamber & .041" gasket.**

**Upgrade available to Little M or SBC Race Series Aluminum blocks.**

*\*Must use small base circle camshaft.*

### SHP CHEVY SHORT BLOCKS

PART NO.	DESCRIPTION	CRANK	PISTONS	RODS	STROKE	BORE
03113722	372 SHP	Cast	Hyper	I-Beam	3.480"	4.125"
	Forged Chevy	Forged	Forged	H-Beam	3.480"	4.125"
03114002	400 SHP	Cast	Hyper	I-Beam	3.750"	4.125"
	Forged Chevy	Forged	Forged	H-Beam	3.750"	4.125"
03124272	427 SHP	Forged	Forged	H-Beam	4.000"	4.125"

# SMALL BLOCK CHEVY TOP END KITS - CAST IRON OR CAST ALUMINUM

## QUICK INFO >>>

Performance matched top end kits from Dart are the perfect way to finish off your Dart short block or upgrade your existing engine.

Dart top end kits for small block Chevy engines offer a full compliment of performance matched parts that make building your engine simple and easy. These kits were designed to deliver excellent performance at a great price.

## DART TOP END KITS INCLUDE

- Fully assembled cylinder heads.
- Chromed steel valve covers - standard (cast upgrade available).
- Intake manifold, selected to compliment the cylinder heads.
- Intake gaskets, head gaskets, and exhaust gaskets.
- Spark plugs.
- Head bolts.



See pages 23-29 for more information on the Iron Eagle cylinder heads used in these kits.

## SBC TOP END KITS WITH IRON EAGLE CYLINDER HEADS

PART NO.	HEADS	PORTS	CHAMBER	PLUGS	VALVES	SPRINGS	MANIFOLD
01111111	Iron	180cc	64cc	Straight	2.020/1.600"	1.250"	Dual Plane
01111112	Iron	180cc	64cc	Straight	2.020/1.600"	1.437"	Dual Plane
01111101	Iron	200cc	64cc	Straight	2.020/1.600"	1.250"	Dual Plane
01111102	Iron	200cc	64cc	Straight	2.020/1.600"	1.437"	Dual Plane
01111002	Iron	215cc	64cc	Straight	2.050/1.600"	1.437"	Single Plane
01110002	Iron	215cc	64cc	Angle	2.050/1.600"	1.437"	Single Plane
01111003	Iron	230cc	64cc	Straight	2.080/1.600"	1.550"	Single Plane
01110003	Iron	230cc	64cc	Angle	2.080/1.600"	1.550"	Single Plane

\*Also available with 72cc combustion chambers.



See page 30-32 for more information on SHP cylinder heads used in these kits.

## SBC TOP END KITS WITH SHP ALUMINUM CYLINDER HEADS

PART NO.	HEADS	PORTS	CHAMBER	PLUGS	VALVES	SPRINGS	MANIFOLD
01311111	Alum	180cc	64cc	Straight	2.020/1.600"	1.250"	Dual Plane
01311112	Alum	180cc	64cc	Straight	2.020/1.600"	1.437"	Dual Plane
01311121	Alum	180cc	72cc	Straight	2.020/1.600"	1.250"	Dual Plane
01311122	Alum	180cc	72cc	Straight	2.020/1.600"	1.437"	Dual Plane
01311132	Alum	200cc	64cc	Straight	2.020/1.600"	1.437"	Dual Plane
01311142	Alum	200cc	72cc	Straight	2.020/1.600"	1.437"	Dual Plane



See pages 33-40 for more information on PRO1 cylinder heads used in these kits.

## SBC TOP END KITS WITH PRO1 ALUMINUM CYLINDER HEADS

PART NO.	HEADS	PORTS	CHAMBER	PLUGS	VALVES	SPRINGS	MANIFOLD
01211111	Alum	180cc	64cc	Straight	2.020/1.600"	1.250"	Dual Plane
01211112	Alum	180cc	64cc	Straight	2.020/1.600"	1.437"	Dual Plane
01211101	Alum	200cc	64cc	Straight	2.020/1.600"	1.250"	Dual Plane
01211102	Alum	200cc	64cc	Straight	2.020/1.600"	1.437"	Dual Plane
01211002	Alum	215cc	64cc	Straight	2.050/1.600"	1.437"	Single Plane
01210002	Alum	215cc	64cc	Angle	2.050/1.600"	1.437"	Single Plane
01211003	Alum	230cc	64cc	Straight	2.080/1.600"	1.550"	Single Plane
01210003	Alum	230cc	64cc	Angle	2.080/1.600"	1.550"	Single Plane

\*Also available with 72cc combustion chambers.

BILLET

HON

SBF

BBC

LS

SBC

ACCESS

MANIFOLDS

HEADS

BLOCKS

TOP END KITS

SHORT BLOCKS



# SMALL BLOCK CHEVY CAST IRON ENGINE BLOCKS

## SIAMESE AND NON-SIAMESE

### QUICK INFO >>>

Excellent upgrade or stock replacement block. Street performance, Sportsman racing.

Designed for high performance and medium duty applications, the SHP (Special High Performance) block is the ideal starting point for hot rodders, drag racers, circle track competitors, off-roaders, and high performance marine enthusiasts.

Don't waste your valuable time sourcing, cleaning, machining and prepping a 40 year old core when you can have a brand new precision machined block with all the most desirable features for just a few dollars more.

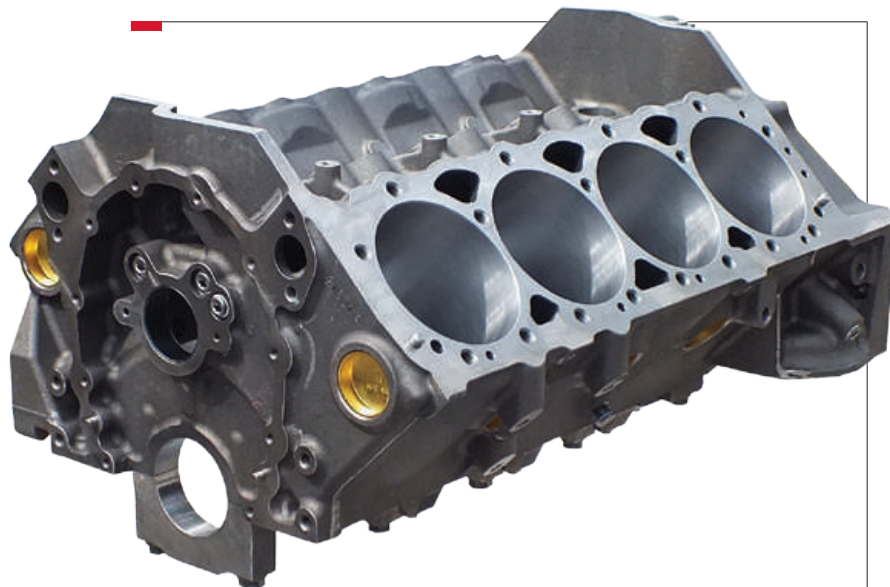

### FEATURES

- Priority main oiling system.
- Siamese cylinder bores with extra thick walls.
- Optional full water jacketed non-siamese cylinder bores.
- Extra thick decks ensure reliable head gasket seal.
- Blind head bolt holes don't go through to water jacket.
- Scalloped water jacket walls improve flow around cylinders for better cooling.
- Clearance for 3.750" stroke with steel rods.
- Splayed outer bolts on middle main bearing caps.
- Non-siamese water blocks have 2-bolt mains on all 5 locations.
- Uses +.300" tall stock 87-95 roller lifters.
- Provisions for OE stock roller lifters & cams.
- Uses 1981-1985 stock style oil pan & passenger side dipstick.
- Uses stock stamped steel or plastic timing cover.
- All OE bolt holes for starter, clutch ball, etc.
- Oil restrictors available through aftermarket resources.
- Parts kit sold separately (PN 32000013 - see page 115).

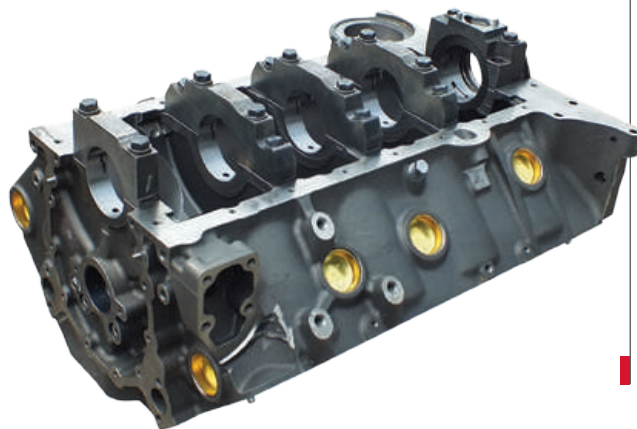

### SPECIAL HIGH PERFORMANCE [SIAMESE] - IRON

PART NO.	DESCRIPTION	REAR SEAL	CAPS	MAINS	DECK	BORE
31161111	SHP Block	2-Piece	Ductile	350	9.025"	4.000"
31161211	SHP Block	2-Piece	Ductile	350	9.025"	4.125"
31161111L	SHP Block	1-Piece*	Ductile	350	9.025"	4.000"
31161211L	SHP Block	1-Piece*	Ductile	350	9.025"	4.125"
31162111	SHP Block	2-Piece	Ductile	400	9.025"	4.000"
31162211	SHP Block	2-Piece	Ductile	400	9.025"	4.125"

### SPECIAL HIGH PERFORMANCE WATER [NON-SIAMESE] / [2-BOLT] - IRON

PART NO.	DESCRIPTION	REAR SEAL	CAPS	MAINS	DECK	BORE
31171111	SHP Block Non-Siamese	2-Piece	2-Bolt Ductile	350	9.025"	4.000"
31171111L	SHP Block Non-Siamese	1-Piece*	2-Bolt Ductile	350	9.025"	4.000"

\* Adapter for 1-Piece rear seal is included.

### SHP SPECS

Material:	Class 30 Grey Iron
Deck Height:	9.025"
Cylinder Bores	4.000" or 4.125"
Siamesed:	4.165" (max)
Non-Siamesed:	4.000" to 4.060" (max)
Main Bearings:	350 or 400
Main Caps:	Ductile Iron
	4-bolt #2, 3 & 4
	2-bolt #1 & 5
Cam Location:	Stock
Lifter Bores:	Stock 87-95 style
Freeze Plugs:	Press fit
Rear Seal:	1 or 2-Piece
Weight:	170-178 lbs.





# SMALL BLOCK CHEVY CAST IRON ENGINE BLOCKS

## QUICK INFO >>>

Upgraded version of the SHP for high RPM applications. Emphasis on racing use.

The SHP PRO has been upgraded with machining options which were previously only available as custom modifications.

With all the standard features of the SHP (Special High Performance) block plus upgraded mains, cam and lifters, the SHP PRO block is the ideal foundation for small block engines with high RPM potential. The added stability provided by upgraded valve train and bottom end components improve both performance and reliability at sustained high RPM.

## UPGRADES

- Upgraded with Billet Steel 4-bolt main caps.
- Upgraded with ARP main stud kit.
- Upgraded with .904" lifter bores.
- Upgraded with BBC cam journal.
- Parts kit included (PN 32000014 - see page 115).

## PLUS STANDARD SHP FEATURES

- Priority main oiling system.
- Oil restrictors available throught aftermarket resources.
- Siamese cylinder bores with extra thick walls.
- Extra thick decks ensure a reliable head gasket seal.
- Blind head bolt holes don't go through to water jacket.
- Clearance for 3.750" stroke w/steel rods.
- Splayed outer bolts on middle main bearing caps.
- All OE bolt holes for starter, clutch ball, etc.

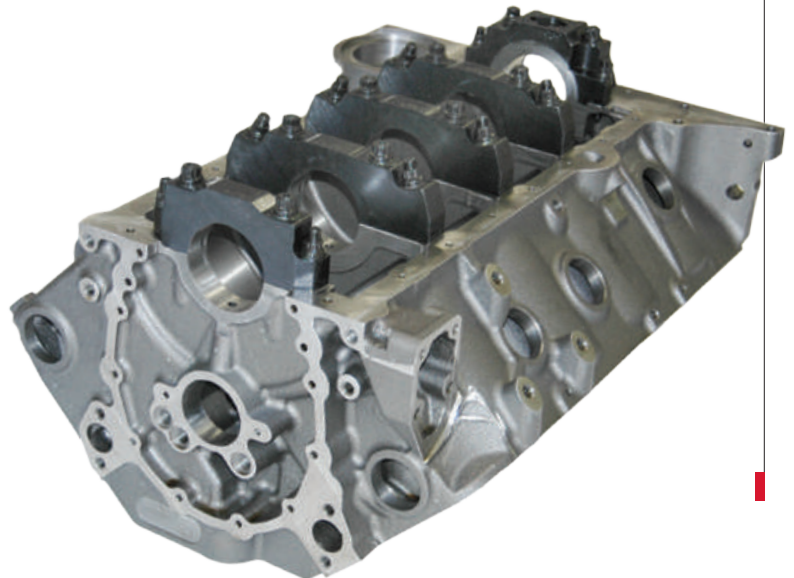
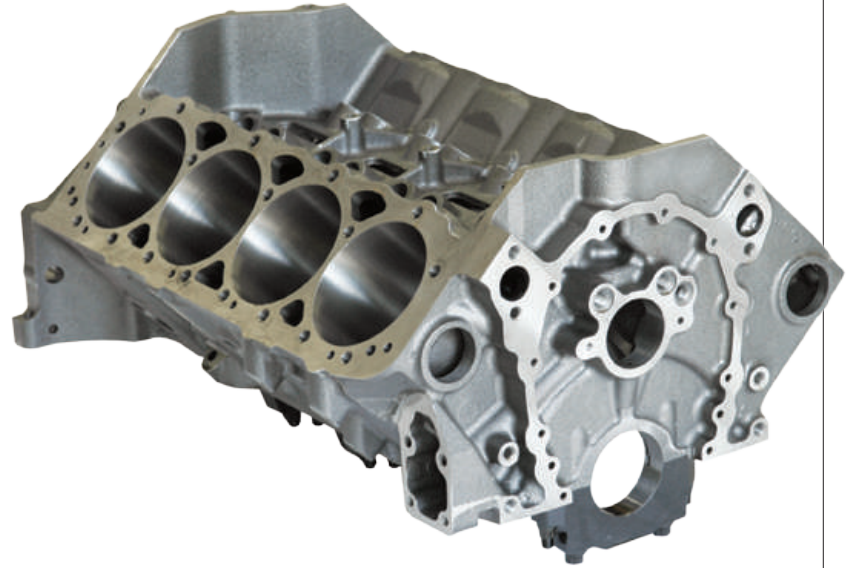

## SPECIAL HIGH PERFORMANCE PRO - IRON

PART NO.	DESCRIPTION	REAR SEAL	CAPS	MAINS	DECK	BORE
31161112	SHP PRO	2-Piece	Steel	350	9.025"	4.000"
31161212	SHP PRO	2-Piece	Steel	350	9.025"	4.125"
31162112	SHP PRO	2-Piece	Steel	400	9.025"	4.000"
31162212	SHP PRO	2-Piece	Steel	400	9.025"	4.125"

## SHP PRO SPECS

Material:	Class 30 Grey Iron
Deck Height:	9.025"
Cylinder Bores:	4.000" or 4.125" 4.165" (max)
Main Bearings:	350 or 400
Main Caps:	Steel 4-bolt (all)
Cam Location:	Stock
Cam Journal:	BBC
Lifter Bores:	.904" dia.
Freeze Plugs:	Press fit
Rear Seal:	2-Piece
Weight:	170-178 lbs.

BILLET

HON

SBF

BBC

LS

SBC

ACCESS

MANIFOLDS

HEADS

BLOCKS

TOP END KITS

SHORT BLOCKS

# LITTLE M

## 305 WATER SMALL BLOCK CHEVY CAST IRON ENGINE BLOCKS

### QUICK INFO >>>

Excellent upgrade for stock replacement, street performance, Sportsman racing, circle track and legal for 305 RACESAVER® Sprint Series.

In order to accommodate the needs of racers in classes that require engines with stock displacements, Dart is now offering a Cast Iron Little M 305 water block with 3.750" cylinder bores.

The new Little M 305 water block has non-siamased cylinder bores, priority main oiling and thick decks with blind head bolt holes that give the Little M block its reputation for reliability and excellent performance.



### FEATURES

- Uses standard small block parts, including cam, timing chain, oil pump, oil pan, oil filter, motor mounts, mechanical fuel pump and clutch linkage.
- Priority main oiling system oils the main bearings first.
- Open lifter valley improves oil return to pan.
- Enlarged lifter bosses accommodate offset and oversized lifters.
- Blind head bolt holes don't go through to water jacket.
- Splayed outer bolts on middle main bearing caps.
- Rear external oil feed, crossover and restrictor provision.
- Parts kit sold separately (PN: 32000001 - see page 115).

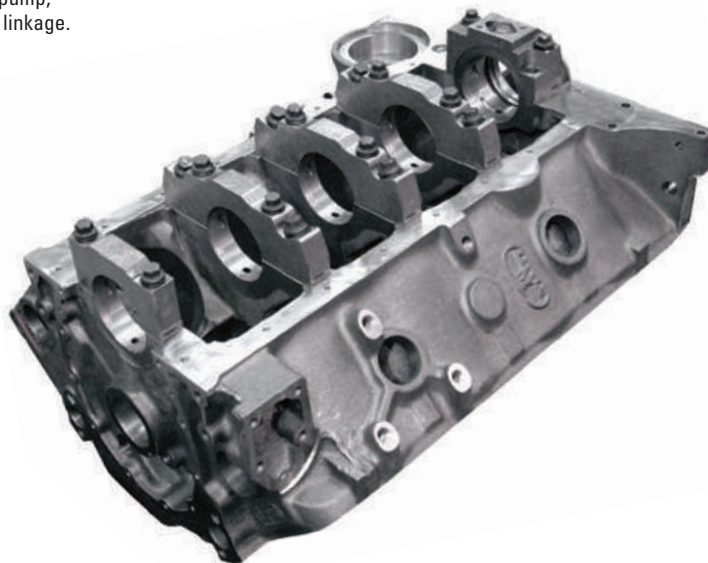

### LITTLE M 305 WATER SPECS

Material:	220 BHN Cast Iron
Deck Height:	9.025"
Cylinder Bores:	3.750" or 3.810" (max)
Main Caps:	Ductile
Cam Location:	Standard
Lifter Bores:	Standard .842"
Freeze Plugs:	Press fit
Rear Seal:	2-Piece
Weight:	194 lbs.

### LITTLE M 305 WATER - IRON

PART NO.	DESCRIPTION	REAR SEAL	CAPS	MAINS	DECK	BORE
31151411	Water Block	2-Piece	Ductile	350	9.025"	3.750"

**LITTLE M**

**SPORTSMAN**

**SMALL BLOCK CHEVY  
CAST IRON ENGINE BLOCKS**

**QUICK INFO >>>**

*Excellent racing, marine performance upgrade or stock replacement block. Street performance, Sportsman racing.*

Dart's Little M Sportsman block is the affordable alternative for Sportsman racers and serious street performance.

The Sportsman block shares most of the Little M's best features, but saves you money by using Ductile Iron main bearing caps (4-bolt on the center three and 2-bolt on the ends), and employing a rear external oil feed, crossover and restrictor provision.

**FEATURES**

- Uses standard small block parts, including cam, timing chain, oil pump, oil pan, oil filter, motor mounts, mechanical fuel pump, and clutch linkage.
- Priority main oiling system feeds the main bearings first.
- Siamese cylinder bores with extra thick walls resist cracking and improve ring seal for more power (minimum .275" thick with 4.185" bore).
- Scalloped water jacket walls improve flow around cylinders for better cooling.
- Open lifter valley improves oil return to pan.
- Enlarged lifter bosses accommodate offset and oversize lifters.
- Blind head bolt holes don't go through to water jacket.
- Splayed outer bolts on middle main bearing caps.
- Rear external oil feed, crossover and restrictor provision.
- Parts kit sold separately (PN 32000001 - see page 115).

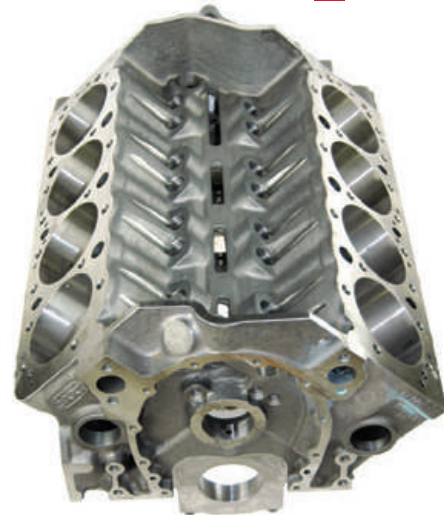

**LITTLE M SPORTSMAN - IRON**

PART NO.	DESCRIPTION	REAR SEAL	CAPS	MAINS	DECK	BORE
31151111	Sportsman Block	2-Piece	Ductile	350	9.025"	4.000"
31151211	Sportsman Block	2-Piece	Ductile	350	9.025"	4.125"
31152111	Sportsman Block	2-Piece	Ductile	400	9.025"	4.000"
31152211	Sportsman Block	2-Piece	Ductile	400	9.025"	4.125"

**LITTLE M SPORTSMAN SPECS**

- Material: 220 BHN Cast Iron
- Deck Height: 9.025" (stock)
- Cylinder Bores: 4.000" or 4.125" 4.185" (max)
- Main Bearings: 350 or 400
- Main Caps: Ductile Iron 4-bolt #2, 3 & 4 2-bolt #1 & 5
- Cam Location: Stock
- Lifter Bores: Stock .842"
- Freeze Plugs: Press fit
- Rear Seal: 2-Piece
- Weight: 197-205 lbs.

BILLET

HON

SBF

BBC

LS

SBC

ACCESS

MANIFOLDS

HEADS

BLOCKS

TOP END KITS

SHORT BLOCKS

# LITTLE M

## SMALL BLOCK CHEVY CAST IRON ENGINE BLOCKS

### QUICK INFO >>>

True race block which will work with most standard components. Provisions for wet or dry sump oiling systems. Great for power adders and maximum effort engines.

The Dart Little M is designed from the ground up as a true racing engine block which can be used with standard off the shelf small block components.

The Little M is cast from premium high strength Iron and beefed up in all the critical areas. A competition oiling system ensures adequate lubrication to the main bearings at high RPM. Front and rear external oil feed, crossover and restrictor provision simplify plumbing with external pumps.

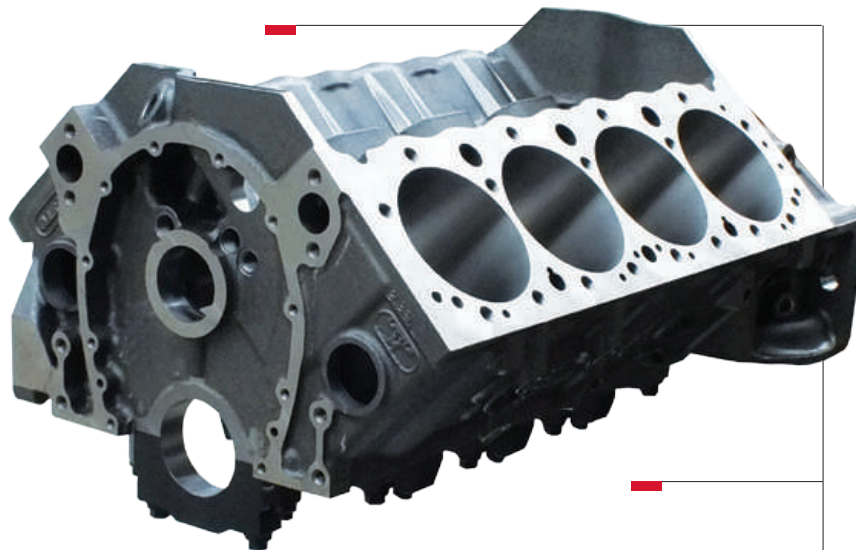

### FEATURES

- Uses standard small block parts, including cam, timing chain, oil pump, oil pan, oil filter, motor mounts, mechanical fuel pump, and clutch linkage.
- Priority main oiling system feeds main bearings first.
- Siamese cylinder bores with extra thick walls resist cracking and improve ring seal for more power (minimum .275" thick with 4.185" bore).
- Open lifter valley improves oil return to pan.
- Enlarged lifter bosses accommodate offset and oversize lifters.
- Blind head bolt holes don't go through to water jacket.
- Billet steel 4-bolt main bearing caps on all 5 mains.
- Front & rear external oil feed, crossover and restrictor provision to simplify use of external oil pumps.
- Parts kit included (PN 32000001 - see page 115).

Dart blocks can be special ordered with a wide array of special machining options to suit your specific requirements.

### LITTLE M SPECS

Material:	220 BHN Cast Iron
Deck Height:	9.025" (stock)
Cylinder Bores:	4.000" or 4.125" 4.185"(max)
Main Bearings:	350 or 400
Main Caps:	Steel 4-bolt
Cam Location:	Stock
Lifter Bores:	Stock .842"
Freeze Plugs:	Press fit
Rear Seal:	2-Piece
Weight:	197-205 lbs.

### LITTLE M - IRON

PART NO.	DESCRIPTION	REAR SEAL	CAPS	MAINS	DECK	BORE
31131111	Little M	2-Piece	Steel	350	9.025"	4.000"
31131211	Little M	2-Piece	Steel	350	9.025"	4.125"
31132111	Little M	2-Piece	Steel	400	9.025"	4.000"
31132211	Little M	2-Piece	Steel	400	9.025"	4.125"



# SMALL BLOCK CHEVY CAST IRON ENGINE BLOCKS

## QUICK INFO >>>

Race block available with tall deck and with raised cam location. Provisions for wet or dry sump oiling systems. Maximum effort racing engines.

Iron Eagle small blocks are available in standard (9.025") and tall deck (9.325") versions so you can select the crankshaft stroke and connecting rod length that's right for your combination.

We raised the camshaft and spread the oil pan rails to provide extra clearance for stroker cranks. The versatile Iron Eagle block is the perfect starting point for a big cubic inch small block project.

## FEATURES

- Standard 9.025" and tall deck 9.325" versions allow greater versatility.
- Custom deck heights as low as 8.200" and as tall as 9.400" available.
- Raised camshaft .391" (4.912" camshaft-to-crankshaft centerlines) provides more clearance for stroker cranks and eliminates need for fragile small base circle cams. Option for .434 raised cam also available.
- Relocated oil pan rails are spread .400" per side (.800" wider than stock) to increase crank/rod clearance and reduce windage losses.
- Requires use of remote oil filter. No provision for block mounted filters.
- Oil pan bolt holes are relocated in line with main caps to eliminate interference with rotating assembly.
- Big block camshaft bearings allow the use of cams with larger base circle diameter to improve strength and reduce twisting with cam-driven pumps (small block cam tunnel available).
- Dual starter mounts allow starter to be mounted on either side of block for chassis and oil pan clearance.
- Front & rear external oil inlets, crossovers and restrictor provisions to simplify plumbing with external pump.
- Parts kit included (PN 32000011 - see page 115).

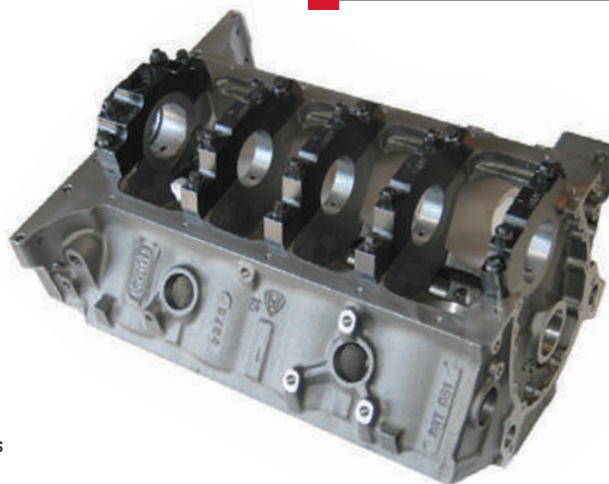
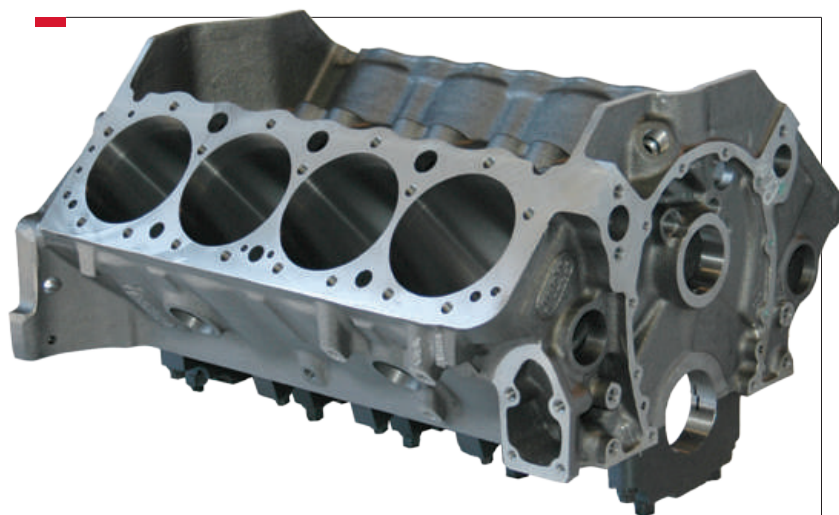

## IRON EAGLE - IRON

PART NO.	DESCRIPTION	CAM LOC.	CAM	CAPS	MAINS	DECK	BORE
31121112	Iron Eagle	+.391"	BBC	Steel	350	9.025"	4.000"
31121212	Iron Eagle	+.391"	BBC	Steel	350	9.025"	4.125"
31121222	Iron Eagle	+.391"	BBC	Steel	350	9.325"	4.125"
31122112	Iron Eagle	+.391"	BBC	Steel	400	9.025"	4.000"
31122212	Iron Eagle	+.391"	BBC	Steel	400	9.025"	4.125"
31122222	Iron Eagle	+.391"	BBC	Steel	400	9.325"	4.125"

## IRON EAGLE SPECS

Material: 220 BHN Cast Iron  
 Deck Heights: 9.025" and 9.325"  
 Cylinder Bores: 4.000" or 4.125"  
 4.185" (max)  
 Main Bearings: 350 or 400  
 Main Caps: Steel 4-bolt  
 Oil Pan Rails: Spread .400"/side  
 Cam Location: Raised .391" or .434"  
 Cam Journal: BBC or SBC  
 Lifter Bores: Stock .842"  
 Freeze Plugs: Press fit  
 Rear Seal: 2-Piece  
 Weight: 198-224 lbs.

BILLET

HON

SBF

BBC

LS

SBC

ACCESS

MANIFOLDS

HEADS

BLOCKS

TOP END KITS

SHORT BLOCKS



# 4.500" BORE SPACE SMALL BLOCK CHEVY CAST IRON ENGINE BLOCKS

## QUICK INFO >>>

Advanced engine builders, maximum competition, unlimited late model, off-road truck. Spread bore space requires special 4.500" cylinder heads and components.

This block features cylinder bores which have been spread to 4.500" from the standard 4.400" center to center dimension. This allows larger bore diameters while maintaining adequate cylinder wall thickness and gasket sealing surface between bores.



## FEATURES

- 4.500" bore spacing allows bore sizes up to 4.250".
- Deck heights of 9.025" up to 9.325" versions allow greater versatility for preferred rod ratio and angle.
- Custom deck heights as low as 8.200" and as tall as 9.400" available.
- Raised camshaft .391" (4.912" camshaft-to-crankshaft centerlines) Option for .434" raised cam also available.
- Relocated oil pan rails are spread .400" per side (.800" wider than stock) to increase crank/rod clearance and reduce windage losses.
- Requires use of remote oil filter. No provision for block mounted filters.
- Oil pan bolt holes are relocated in line with main caps to eliminate interference with rotating assembly.
- Big block camshaft bearings allow the use of cams with larger base circle diameter to improve strength and reduce twisting with cam-driven pumps.
- Dual starter mounts allow starter to be mounted on either side of block for chassis and oil pan clearance.
- Front & rear external oil inlets, crossovers and restrictor provisions to simplify plumbing with an external pump.
- Parts kit included (PN 32000011 - see page 115).

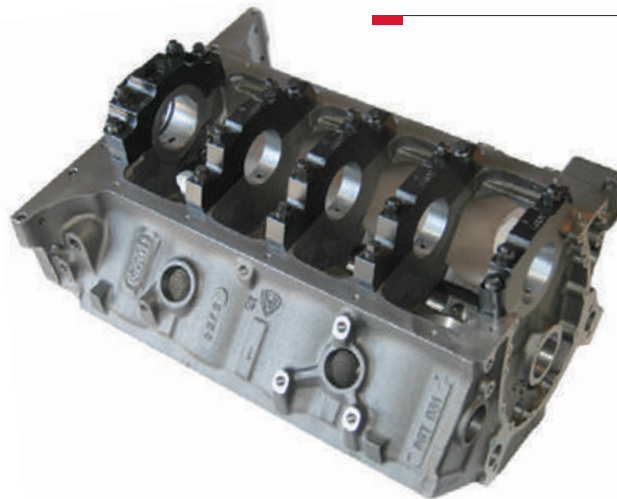

## IRON EAGLE 4.500" BORE SPACE - IRON

PART NO.	DESCRIPTION	CAM LOC.	CAM	CAPS	MAINS	DECK	BORE
31521312	4.500" Bore Space	+ .391"	BBC	Steel	350	9.025"	4.180"
31521313	4.500" Bore Space	+ .391"	50mm	Steel	350	9.025"	4.180"
31521342	4.500" Bore Space	+ .391"	BBC	Steel	350	9.075"	4.180"
31521322	4.500" Bore Space	+ .391"	BBC	Steel	350	9.325"	4.180"
31522312	4.500" Bore Space	+ .391"	BBC	Steel	400	9.025"	4.180"
31522313	4.500" Bore Space	+ .391"	50mm	Steel	400	9.025"	4.180"
31522342	4.500" Bore Space	+ .391"	BBC	Steel	400	9.075"	4.180"
31522322	4.500" Bore Space	+ .391"	BBC	Steel	400	9.325"	4.180"
31522323	4.500" Bore Space	+ .391"	50mm	Steel	400	9.325"	4.180"

## IRON EAGLE 4.500" SPECS

Material:	220 BHN Cast Iron
Deck Height:	9.025" to 9.325"
Bore Spacing:	4.500"
Cylinder Bores:	4.180" 4.250" (max)
Main Bearings:	350 or 400
Main Caps:	Steel 4-bolt
Oil Pan Rails:	Spread .400"/side
Cam Location:	Raised .391" or .434"
Cam Journal:	BBC or 50mm
Lifter Bores:	Stock .842"
Freeze Plugs:	Press fit
Rear Seal:	2-Piece
Weight:	208-224 lbs.



# SMALL BLOCK CHEVY CAST ALUMINUM ENGINE BLOCKS

## QUICK INFO >>>

Race block available with tall deck and with raised cam location. Can be used in Sprint car, modified and late model stock car classes. As well as dragster and unlimited competition classes.

We created all new tooling and added superior new features like central oil cross-overs and extended cylinder barrels.

Deck heights from 8.850" to 9.500" are available. Dart's Aluminum small block is light, strong, and affordable.

## FEATURES

- Deck heights from 8.850" to 9.500" provide maximum versatility. Cylinder barrels are extended at the bottom for better piston support with long strokes.
- Raised camshaft (+.391") provides more clearance for stroker cranks and eliminates need for fragile small base circle cams. Option for .434" raised cam.
- Siamesed 4.000" or 4.125" cylinders can be safely bored to 4.165". Ductile Iron sleeves and extra thick walls produce excellent ring seal.
- Requires use of remote oil filter. No provision for block mounted filters.
- Relocated oil pan rails are spread .400" per side (.800" wider than stock). Oil pan bolt holes are relocated in line with main caps.
- Big block camshaft bearings allow the use of cams with larger base circle diameter to improve strength and reduce twisting with cam driven pumps.
- Rear external oil inlets, with crossovers and restrictor provisions located centrally in the valley to simplify plumbing with external pump.
- Parts kit included (PN 32000012 - see page 115).



## RACE SERIES - ALUMINUM

PART NO.	DESCRIPTION	CAM LOC.	CAM	CAPS	MAINS	DECK	BORE
31711152	SBC Aluminum	+.391"	BBC	Steel	350	8.850"	4.000"
31711252	SBC Aluminum	+.391"	BBC	Steel	350	8.850"	4.125"
31711112	SBC Aluminum	+.391"	BBC	Steel	350	9.025"	4.000"
31711113	SBC Aluminum	+.391"	50mm	Steel	350	9.025"	4.000"
31711212	SBC Aluminum	+.391"	BBC	Steel	350	9.025"	4.125"
31711213	SBC Aluminum	+.391"	50mm	Steel	350	9.025"	4.125"
31711242	SBC Aluminum	+.391"	BBC	Steel	350	9.075"	4.125"
31711122	SBC Aluminum	+.391"	BBC	Steel	350	9.325"	4.000"
31711222	SBC Aluminum	+.391"	BBC	Steel	350	9.325"	4.125"
31711132	SBC Aluminum	+.391"	BBC	Steel	350	9.500"	4.000"
31711232	SBC Aluminum	+.391"	BBC	Steel	350	9.500"	4.125"
31712112	SBC Aluminum	+.391"	BBC	Steel	400	9.025"	4.000"
31712212	SBC Aluminum	+.391"	BBC	Steel	400	9.025"	4.125"
31712213	SBC Aluminum	+.391"	50mm	Steel	400	9.025"	4.125"
31712142	SBC Aluminum	+.391"	BBC	Steel	400	9.075"	4.000"
31712242	SBC Aluminum	+.391"	BBC	Steel	400	9.075"	4.125"
31712122	SBC Aluminum	+.391"	BBC	Steel	400	9.325"	4.000"
31712222	SBC Aluminum	+.391"	BBC	Steel	400	9.325"	4.125"
31712132	SBC Aluminum	+.391"	BBC	Steel	400	9.500"	4.000"
31712232	SBC Aluminum	+.391"	BBC	Steel	400	9.500"	4.125"

## RACE SERIES SPECS

- Material: RMR Cast Aluminum Alloy
- Deck Height: 8.850" to 9.500"
- Cylinder Bores: 4.000" or 4.125" 4.165" (max)
- Main Bearings: 350 or 400
- Main Caps: Steel 4-bolt
- Oil Pan Rails: Spread .400"/side
- Cam Location: Raised .391" or .434"
- Cam Journal: BBC or 50mm
- Lifter Bores: Stock .842"
- Freeze Plugs: Screw-in
- Rear Seal: 2-Piece
- Weight: 105 lbs.

BILLET

HON

SBF

BBC

LS

SBC

ACCESS

MANIFOLDS

HEADS

BLOCKS

TOP END KITS

SHORT BLOCKS

# RACE SERIES

## 4.500" BORE SPACE SMALL BLOCK CHEVY CAST ALUMINUM ENGINE BLOCKS

### QUICK INFO >>>

Advanced engine builders, maximum competition, unlimited late model, off-road truck. Spread bore space requires special 4.500" cylinder heads and components.

The Race Series Aluminum block features cylinder bores which have been spread to 4.500" from the standard 4.400" center to center dimension. This allows larger bore diameters while maintaining adequate cylinder wall thickness and gasket sealing surface between bores.

### FEATURES

- Premium alloy: Dart Aluminum blocks are cast from proprietary RMR cast Aluminum alloy for superior strength.
- 4.500" bore spacing allows bore sizes up to 4.250".
- Standard 17 head bolt pattern or optional 19 bolt pattern available.
- Deck heights of 8.850", 9.025", 9.075" and tall deck 9.325" & 9.500" versions allow greater versatility for preferred rod ratio and angle.
- Raised camshaft .391" (4.912" camshaft-to-crankshaft centerlines) Option for .434" raised cam also available.
- Requires use of remote oil filter. No provision for block mounted filters.
- Relocated oil pan rails are spread .400" per side (.800" wider than stock) to increase crank/rod clearance and reduce windage losses.
- Big block camshaft bearings allow the use of cams with larger base circle diameter to improve strength and reduce twisting with cam-driven pumps.
- Rear external oil inlets, with crossovers and restrictor provisions located centrally in the valley.
- Parts kit included (PN 32000012 - see page 115).

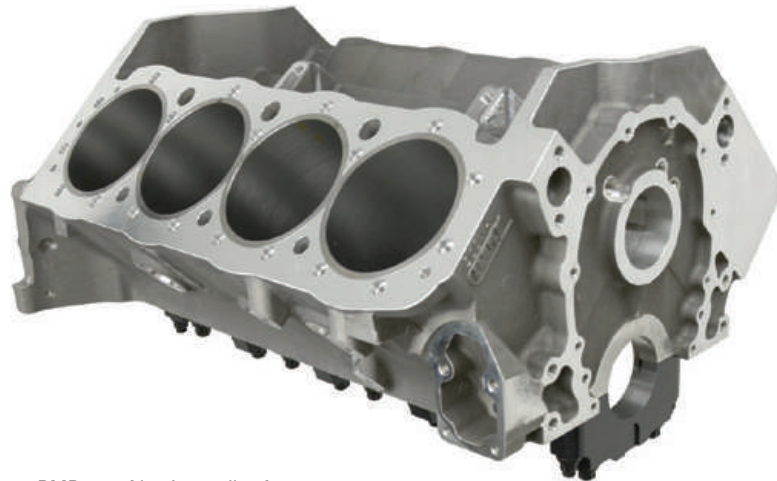

### RACE SERIES 4.500" - ALUMINUM

PART NO.	DESCRIPTION	CAM LOC.	CAM	CAPS	MAINS	DECK	BORE
31511352	SBC Aluminum	+.391"	50mm	Steel	350	8.850"	4.180"
31511312	SBC Aluminum	+.391"	BBC	Steel	350	9.025"	4.180"
31511313	SBC Aluminum	+.391"	50mm	Steel	350	9.025"	4.180"
31511342	SBC Aluminum	+.391"	BBC	Steel	350	9.075"	4.180"
31511322	SBC Aluminum	+.391"	BBC	Steel	350	9.325"	4.180"
31511332	SBC Aluminum	+.391"	BBC	Steel	350	9.500"	4.180"
31512312	SBC Aluminum	+.391"	BBC	Steel	400	9.025"	4.180"
31512313	SBC Aluminum	+.391"	50mm	Steel	400	9.025"	4.180"
31512342	SBC Aluminum	+.391"	BBC	Steel	400	9.075"	4.180"
31512322	SBC Aluminum	+.391"	BBC	Steel	400	9.325"	4.180"
31512323	SBC Aluminum	+.391"	50mm	Steel	400	9.325"	4.180"
31512332	SBC Aluminum	+.391"	BBC	Steel	400	9.500"	4.180"

### RACE SERIES 4.500" SPECS

Material:	RMR Cast Aluminum Alloy
Deck Height:	8.850" to 9.500"
Cylinder Bores:	4.180" 4.250" (max)
Main Bearings:	350 or 400
Main Caps:	Steel 4-bolt
Oil Pan Rails:	Spread .400"/side
Cam Location:	Raised .391" or .434"
Cam Journal:	BBC or 50mm
Lifter Bores:	Stock .842"
Freeze Plugs:	Screw-in
Rear Seal:	2-Piece
Weight:	105 lbs.





# 23° 165cc SMALL BLOCK CHEVY S/S CAST IRON CYLINDER HEADS

### QUICK INFO >>>

Stock replacement, street and strip performance, or towing upgrade with mildly modified engines from idle to 5,500 RPM. Best for 305-383 cubic inch engines. Works with most standard components.

Dart Iron Eagle S/S 23° 165cc heads produce great throttle response and low to mid-range torque for street performance engines. Our precision cast ports and chambers produce outstanding air flow without time consuming porting. Dart S/S heads are legal in many racing sanctions with Iron head rules.

Assemblies include Stainless Steel valves, premium springs, locks, retainers, and seals. Guide plates not included for self-aligning rocker styles.

Heads are sold individually.

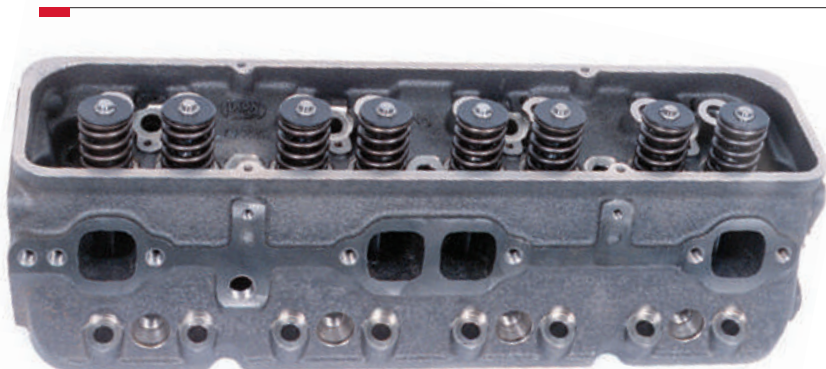

1955-86 STYLE INTAKE FACE



### IRON EAGLE S/S 23° 165cc [55-86 Std. Intake Face]

#### 72cc CHAMBERS - 1.940"/1.500" VALVES

PART NO.	CONFIGURATION FOR USE	MAX. LIFT
10021070	Bare Head	
10021171	1.250" Single Springs for Hydraulic Flat Tappet Cam	.510"

#### 72cc CHAMBERS - 2.020"/1.600" VALVES

PART NO.	CONFIGURATION FOR USE	MAX. LIFT
10021010	Bare Head	
10021111	1.250" Single Springs for Hydraulic Flat Tappet Cam	.510"

### IRON EAGLE S/S 23° 165cc [55-86 Std. Face w/ Self-Aligning Rockers]

#### 67cc CHAMBERS - 1.940"/1.500" VALVES

PART NO.	CONFIGURATION FOR USE	MAX. LIFT
10024361	Bare Head (WISSOTA Spec Head)	
10024361A	1.250" Single Springs for Hydraulic Flat Tappet Cam	.510"

#### 67cc CHAMBERS - 2.020"/1.600" VALVES

PART NO.	CONFIGURATION FOR USE	MAX. LIFT
10024266	Bare Head	
10024266A	1.250" Single Springs for Hydraulic Flat Tappet Cam	.510"

#### 76cc CHAMBERS - 1.940"/1.500" VALVES

PART NO.	CONFIGURATION FOR USE	MAX. LIFT
10024360	Bare Head	
10024360A	1.250" Single Springs for Hydraulic Flat Tappet Cam	.510"

#### 76cc CHAMBERS - 2.020"/1.600" VALVES

PART NO.	CONFIGURATION FOR USE	MAX. LIFT
10024267	Bare Head	
10024267A	1.250" Single Springs for Hydraulic Flat Tappet Cam	.510"

Head parts kit - see page 115.

### RECOMMENDED MANIFOLD

42811000 SHP Dual Plane

### IRON EAGLE S/S 23° 165cc SPECS

Material:	Class 30 Grey Iron
Valve Angle:	23° (stock)
Intake Port Volume:	165cc
Intake Valve:	1.940" or 2.020"
Exhaust Valve:	1.500" or 1.600"
Valve Guides:	Integral Iron
Chamber Volume:	67, 72 or 76cc
Plug Type:	Straight

### FLOW DATA @ 28" WATER

LIFT	INTAKE	EXHAUST
.200"	126	108
.300"	185	128
.400"	221	136
.500"	232	138

BILLET

HON

SBF

BBC

LS

SBC

ACCESS

MANIFOLDS

HEADS

BLOCKS

TOP END KITS

SHORT BLOCKS



**23°  
170cc**  
LATE MODEL &  
VORTEC STYLES

# SMALL BLOCK CHEVY S/S CAST IRON CYLINDER HEADS

### QUICK INFO >>>

Late model and Vortec intake face. Stock replacement, street & strip performance, towing upgrade with mildly modified engines from idle to 5,500 RPM. Best for 305-383 cubic inch engines.

Dart Iron Eagle S/S 23° 170cc late model and Vortec style heads produce great throttle response and low to mid-range torque for street performance engines. Our precision cast ports and chambers produce outstanding air flow without time consuming porting.

Dart S/S heads are legal in many racing sanctions with Iron head rules.

Assemblies include Stainless Steel valves, premium springs, locks, retainers and seals.

*Heads are sold individually.*

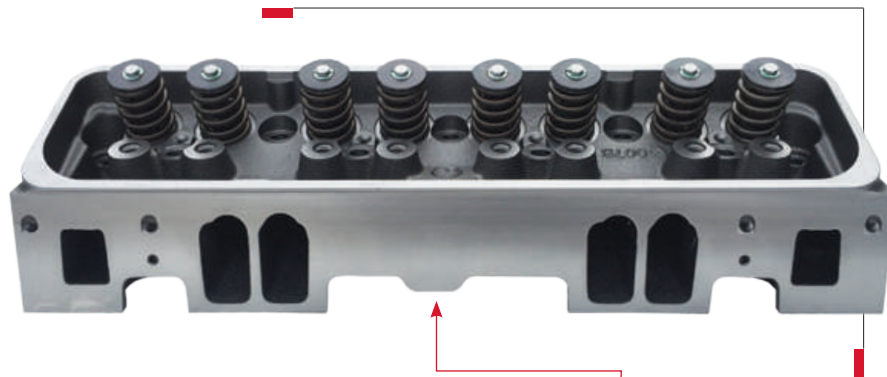

**VORTEC STYLE INTAKE FACE**



Head parts kit - see page 115.

Uses 3/8" screw-in rocker studs.

Uses center-bolt valve covers.

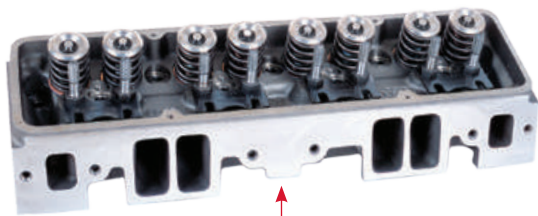

**LATE MODEL  
STYLE INTAKE FACE**

### IRON EAGLE S/S 23° 170cc [87-95 Late Model Intake Face with Self-Aligning Rockers]

#### 67cc CHAMBERS - 1.940"/1.500" VALVES

PART NO.	CONFIGURATION FOR USE	MAX. LIFT
10024365	Bare Head - Center bolt valve covers only	
10024365A	1.250" Single Springs for Hydraulic Flat Tappet Cam	.510"

#### 72cc CHAMBERS - 1.940"/1.500" VALVES

PART NO.	CONFIGURATION FOR USE	MAX. LIFT
10021070S	Bare Head - Center bolt valve covers only	

#### 76cc CHAMBERS - 1.940"/1.500" VALVES

PART NO.	CONFIGURATION FOR USE	MAX. LIFT
10024364	Bare Head - Center bolt valve covers only	
10024364A	1.250" Single Springs for Hydraulic Flat Tappet Cam	.510"

### IRON EAGLE S/S 23° 170cc [96-99 Vortec Intake Face with Self-Aligning Rockers]

#### 67cc CHAMBERS - 1.940"/1.500" VALVES

PART NO.	CONFIGURATION FOR USE	MAX. LIFT
10024370	Bare Head - Center bolt valve covers only	
10024370A	1.250" Single Springs for Hydraulic Flat Tappet Cam	.510"

### IRON EAGLE S/S 23° 170cc SPECS

Material:	Class 30 Grey Iron
Valve Angle:	23° (stock)
Intake Port Volume:	170cc
Intake Valve:	1.940"
Exhaust Valve:	1.500"
Valve Guides:	Integral Iron
Chamber Volume:	67, 72 or 76cc
Plug Type:	Straight

### FLOW DATA @ 28" WATER

LIFT	INTAKE	EXHAUST
.200"	126	108
.300"	185	128
.400"	221	136
.500"	232	138



# 23° 180cc SMALL BLOCK CHEVY CAST IRON CYLINDER HEADS

### QUICK INFO >>>

An excellent street, strip, oval track, truck or marine performance upgrade. Maximum torque and throttle response from idle to 6,000 RPM. Best for 327-400 cubic inch engines. Works with most standard components.

Dart Iron Eagle 23° 180cc cylinder heads are an affordable alternative to more expensive Aluminum heads. These 180cc heads out perform many larger heads in a wide range of applications. Long wearing Bronze valve guides, screw-in studs, multi-angle intake seats and hardened and radiused exhaust seats are standard. Best of all, our precision cast ports produce outstanding airflow without time consuming porting.

Assemblies include Stainless Steel valves, premium springs, locks, retainers, studs, guide plates and seals.

Heads are sold individually.



## IRON EAGLE 23° 180cc [Straight Plug Heads]

### 64cc COMBUSTION CHAMBERS

PART NO.	CONFIGURATION FOR USE	MAX. LIFT
10120010	Bare Head	
10121111	1.250" Single Springs for Hydraulic Flat Tappet Cam	.510"
10121112	1.437" Dual Springs for Hydraulic Roller or Solid Flat Tappet Cam	.650"

### 72cc COMBUSTION CHAMBERS

PART NO.	CONFIGURATION FOR USE	MAX. LIFT
10220010	Bare Head	
10221111	1.250" Single Springs for Hydraulic Flat Tappet Cam	.510"
10221112	1.437" Dual Springs for Hydraulic Roller or Solid Flat Tappet Cam	.650"

## IRON EAGLE 23° 180cc [Angle Plug Heads]

### 49cc COMBUSTION CHAMBERS

PART NO.	CONFIGURATION FOR USE	MAX. LIFT
10110010F	Bare Head	
10111111F	1.250" Single Springs for Hydraulic Flat Tappet Cam	.510"
10111121F	1.437" Dual Springs for Hydraulic Roller or Solid Flat Tappet Cam	.650"

### 64cc COMBUSTION CHAMBERS

PART NO.	CONFIGURATION FOR USE	MAX. LIFT
10110010	Bare Head	
10111111	1.250" Single Springs for Hydraulic Flat Tappet Cam	.510"
10111112	1.437" Dual Springs for Hydraulic Roller or Solid Flat Tappet Cam	.650"

### 72cc COMBUSTION CHAMBERS

PART NO.	CONFIGURATION FOR USE	MAX. LIFT
10210010	Bare Head	
10211111	1.250" Single Springs for Hydraulic Flat Tappet Cam	.510"
10211112	1.437" Dual Springs for Hydraulic Roller or Solid Flat Tappet Cam	.650"

Head parts kit - see page 115.

Uses 3/8" screw-in rocker studs. 7/16" upgrade available.

Heads with 49cc chambers require special 21.5° pistons.

### RECOMMENDED MANIFOLD

42811000 SHP Dual Plane

### IRON EAGLE 23° 180cc SPECS

Material:	220 BHN Cast Iron
Valve Angle:	23° (stock)
Intake Port Volume:	180cc
Intake Valve:	2.020"
Exhaust Valve:	1.600"
Chamber Volume:	49, 64, 72cc
Plug Types:	Straight or angle

### FLOW DATA @ 28" WATER

LIFT	INTAKE	EXHAUST
.200"	139	117
.300"	194	154
.400"	233	179
.500"	260	195
.600"	269	205

BILLET  
HON  
SBF  
BBC  
LS  
SBC  
ACCESS  
MANIFOLDS  
HEADS  
BLOCKS  
TOP END KITS  
SHORT BLOCKS



# 23° 200cc SMALL BLOCK CHEVY CAST IRON CYLINDER HEADS

## QUICK INFO >>>

Street performance, restricted oval track, and marine performance upgrade. Mid-range to 6,500 RPM.

Dart Iron Eagle Platinum 23° 200cc heads offer increased high lift air flow for large displacement engines. Long wearing Bronze valve guides, screw-in studs, multi-angle intake seats and hardened and radiused exhaust seats are standard. Best of all, our precision cast ports produce outstanding airflow without time consuming porting.

Assemblies include Stainless Steel valves, premium springs, locks, retainers, studs, guide plates and seals.

Heads are sold individually.



## IRON EAGLE 23° 200cc [Straight Plug Heads]

### 64cc COMBUSTION CHAMBERS

PART NO.	CONFIGURATION FOR USE	MAX. LIFT
10320010P	Bare Head	
10321111P	1.250" Single Springs for Hydraulic Flat Tappet Cam	.510"
10321112P	1.437" Dual Springs for Hydraulic Roller or Solid Flat Tappet Cam	.650"
10321113P	1.550" Dual Springs for Solid Roller Cam	.700"

### 72cc COMBUSTION CHAMBERS

PART NO.	CONFIGURATION FOR USE	MAX. LIFT
10420010P	Bare Head	
10421111P	1.250" Single Springs for Hydraulic Flat Tappet Cam	.510"
10421112P	1.437" Dual Springs for Hydraulic Roller or Solid Flat Tappet Cam	.650"
10421113P	1.550" Dual Springs for Solid Roller Cam	.700"

## IRON EAGLE 23° 200cc [Angle Plug Heads]

### 49cc COMBUSTION CHAMBERS

PART NO.	CONFIGURATION FOR USE	MAX. LIFT
10310010PF	Bare Head	
10310010PFCT	Bare Head (.502" Guides)	
10311111PF	1.250" Single Springs for Hydraulic Flat Tappet Cam	.510"
10311112PF	1.437" Dual Springs for Hydraulic Roller or Solid Flat Tappet Cam	.650"
10311113PF	1.550" Dual Springs for Solid Roller Cam	.700"

### 64cc COMBUSTION CHAMBERS

PART NO.	CONFIGURATION FOR USE	MAX. LIFT
10310010P	Bare Head	
10311111P	1.250" Single Springs for Hydraulic Flat Tappet Cam	.510"
10311112P	1.437" Dual Springs for Hydraulic Roller or Solid Flat Tappet Cam	.650"
10311113P	1.550" Dual Springs for Solid Roller Cam	.700"

### 72cc COMBUSTION CHAMBERS

PART NO.	CONFIGURATION FOR USE	MAX. LIFT
10410010P	Bare Head	
10411111P	1.250" Single Springs for Hydraulic Flat Tappet Cam	.510"
10411112P	1.437" Dual Springs for Hydraulic Roller or Solid Flat Tappet Cam	.650"
10411113P	1.550" Dual Springs for Solid Roller Cam	.700"

Head parts kit - see page 115.

Uses 3/8" screw-in rocker studs.  
7/16" upgrade available.

Heads with 49cc chambers require special 21.5° pistons.

Assemblies with 1.550" valve spring use +.100" long valves.

## RECOMMENDED MANIFOLD

42811000 SHP Dual Plane

## IRON EAGLE 23° 200cc SPECS

Material:	220 BHN Cast Iron
Valve Angle:	23° (stock)
Intake Port Volume:	200cc
Intake Valve:	2.020"
Exhaust Valve:	1.600"
Chamber Volume:	49, 64, 72cc
Plug Types:	Straight or angle

## FLOW DATA @ 28" WATER

LIFT	INTAKE	EXHAUST
.200"	139	117
.300"	191	154
.400"	235	179
.500"	266	195
.600"	274	205



# 23° 215cc SMALL BLOCK CHEVY CAST IRON CYLINDER HEADS

### QUICK INFO >>>

*Serious street performance, modified oval track and bracket racing. Mid-range to 7,000 RPM.*

Dart Iron Eagle Platinum 23° 215cc heads are for big cubic inch, high RPM applications which favor peak power over low end flexibility.

Long wearing Bronze valve guides, screw-in studs, multi-angle intake seats and hardened and radiused exhaust seats are standard. Best of all, our precision cast ports produce outstanding airflow without time consuming porting.

Assemblies include Stainless Steel valves, premium springs, locks, retainers, studs, guide plates and seals.

**Heads are sold individually.**



Head parts kit - see page 115.

Uses 3/8" screw-in rocker studs. 7/16" upgrade available.

Heads with 49cc chambers require special 21.5° pistons.

Assemblies with 1.550" valve spring use +.100" long valves.

### IRON EAGLE 23° 215cc [Straight Plug Heads]

#### 64cc COMBUSTION CHAMBERS

PART NO.	CONFIGURATION FOR USE	MAX. LIFT
10520020P	Bare Head	
10521122P	1.437" Dual Springs for Hydraulic Roller or Solid Flat Tappet Cam	.650"
10521123P	1.550" Dual Springs for Solid Roller Cam	.700"

#### 72cc COMBUSTION CHAMBERS

PART NO.	CONFIGURATION FOR USE	MAX. LIFT
10620020P	Bare Head	
10621122P	1.437" Dual Springs for Hydraulic Roller or Solid Flat Tappet Cam	.650"
10621123P	1.550" Dual Springs for Solid Roller Cam	.700"

### IRON EAGLE 23° 215cc [Angle Plug Heads]

#### 49cc COMBUSTION CHAMBERS

PART NO.	CONFIGURATION FOR USE	MAX. LIFT
10510020PF	Bare Head	
10511122PF	1.437" Dual Springs for Hydraulic Roller or Solid Flat Tappet Cam	.650"
10511123PF	1.550" Dual Springs for Solid Roller Cam	.700"

#### 64cc COMBUSTION CHAMBERS

PART NO.	CONFIGURATION FOR USE	MAX. LIFT
10510020P	Bare Head	
10511122P	1.437" Dual Springs for Hydraulic Roller or Solid Flat Tappet Cam	.650"
10511123P	1.550" Dual Springs for Solid Roller Cam	.700"

#### 72cc COMBUSTION CHAMBERS

PART NO.	CONFIGURATION FOR USE	MAX. LIFT
10610020P	Bare Head	
10611122P	1.437" Dual Springs for Hydraulic Roller or Solid Flat Tappet Cam	.650"
10611123P	1.550" Dual Springs for Solid Roller Cam	.700"

### RECOMMENDED MANIFOLD

**42411000** Single Plane

### IRON EAGLE 23° 215cc SPECS

Material:	220 BHN Cast Iron
Valve Angle:	23° (stock)
Intake Port Volume:	215cc
Intake Valve:	2.050"
Exhaust Valve:	1.600"
Chamber Volume:	49, 64, 72cc
Plug Types:	Straight or angle

### FLOW DATA @ 28" WATER

LIFT	INTAKE	EXHAUST
.200"	132	117
.300"	189	154
.400"	232	179
.500"	263	195
.600"	283	205

BILLET

HON

SBF

BBC

LS

SBC

ACCESS

MANIFOLDS

HEADS

BLOCKS

TOP END KITS

SHORT BLOCKS



# 23° 230cc SMALL BLOCK CHEVY CAST IRON CYLINDER HEADS

### QUICK INFO >>>

Street performance, restricted oval track, and marine performance upgrade. Mid-range to 6,500 RPM. Best for 383-434 cubic inch engines.

Iron Eagle 23° 230cc Platinum heads are intended for maximum effort competition engines with large displacements and very high RPM usage.

Long wearing Bronze valve guides, screw-in studs, multi-angle intake seats with hardened and radiused exhaust seats are standard. Best of all, our precision cast ports produce outstanding airflow without time consuming porting.

Assemblies include Stainless Steel valves, premium springs, locks, retainers, studs, guide plates and seals.

Heads are sold individually.



Head parts kit - see page 115.

Uses 3/8" screw-in rocker studs.  
7/16" upgrade available.

Heads with 49cc chambers require special 21.5° pistons.

Assemblies with 1.550" valve spring use +.100" long valves.

### IRON EAGLE 23° 230cc [Straight Plug Heads]

#### 64cc COMBUSTION CHAMBERS

PART NO.	CONFIGURATION FOR USE	MAX. LIFT
10720040P	Bare Head	
10721143P	1.550" Dual Springs for Solid Roller Cam	.700"

#### 72cc COMBUSTION CHAMBERS

PART NO.	CONFIGURATION FOR USE	MAX. LIFT
10820040P	Bare Head	
10821143P	1.550" Dual Springs for Solid Roller Cam	.700"

### IRON EAGLE 23° 230cc [Angle Plug Heads]

#### 49cc COMBUSTION CHAMBERS

PART NO.	CONFIGURATION FOR USE	MAX. LIFT
10710040PF	Bare Head	
10711143PF	1.550" Dual Springs for Solid Roller Cam	.700"

#### 64cc COMBUSTION CHAMBERS

PART NO.	CONFIGURATION FOR USE	MAX. LIFT
10710040P	Bare Head	
10711143P	1.550" Dual Springs for Solid Roller Cam	.700"

#### 72cc COMBUSTION CHAMBERS

PART NO.	CONFIGURATION FOR USE	MAX. LIFT
10810040P	Bare Head	
10811143P	1.550" Dual Springs for Solid Roller Cam	.700"

### RECOMMENDED MANIFOLDS

42411000 Single Plane  
42421000 Single Plane (4500)

### IRON EAGLE 23° 230cc SPECS

Material:	220 BHN Cast Iron
Valve Angle:	23° (stock)
Intake Port Volume:	230cc
Intake Valve:	2.080"
Exhaust Valve:	1.600"
Chamber Volume:	49, 64, 72cc
Plug Types:	Straight or angle

### FLOW DATA @ 28" WATER

LIFT	INTAKE	EXHAUST
.200"	129	115
.300"	184	158
.400"	231	185
.500"	271	199
.600"	296	205
.700"	308	207



**23°  
227cc  
CNC**

# SMALL BLOCK CHEVY CAST IRON CYLINDER HEADS

### QUICK INFO >>>

Fully CNC ported. Maximum performance/full competition, unlimited oval and super classes. 7,000+ RPM, 400+ cubic inch engines.

Completely CNC machined, the Iron Eagle 23° 227cc CNC heads offer ultimate consistency and performance. With intake ports designed to optimize fuel/air flow efficiency and combustion chambers that offer a more complete and rapid burn, these heads are perfect for big inch small blocks.

Standard valve angle and spacing are retained to allow use of off the shelf pistons and valve train components.

Hardened exhaust seats are compatible with unleaded gasoline. Manganese Bronze valve guides extend cylinder head life.

**Heads are sold individually.**

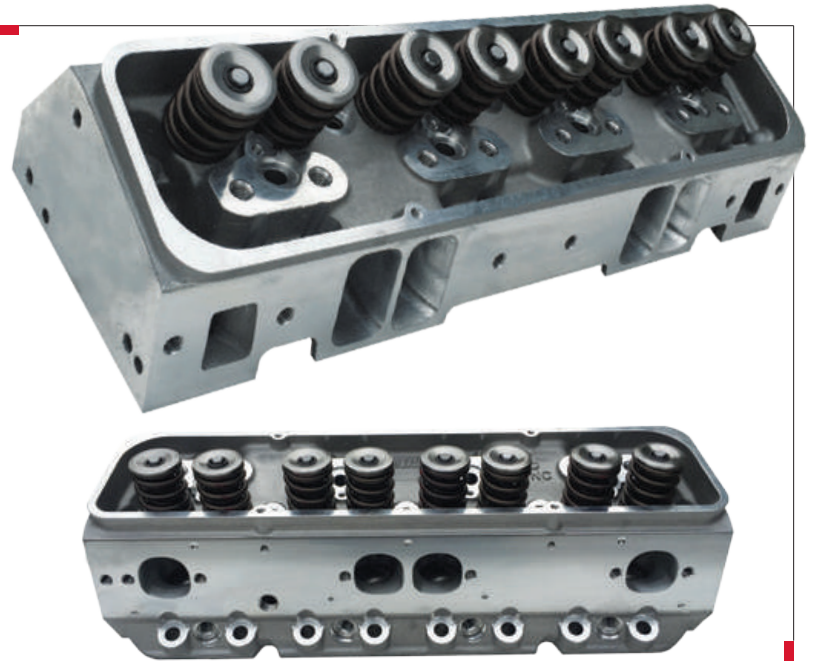

Head parts kit - see page 115.

Uses 7/16" screw-in rocker studs.

Assembles with 1.550" valve spring use +.100" long valves.

### IRON EAGLE 23° 227cc CNC [Angle Plug Heads]

#### 72cc COMBUSTION CHAMBERS

PART NO.	CONFIGURATION FOR USE	MAX. LIFT
10970040	Bare Head	
10971142	1.437" Dual Springs for Hydraulic Roller or Solid Flat Tappet Cam	.650"
10971143	1.550" Dual Springs for Solid Roller Cam	.700"

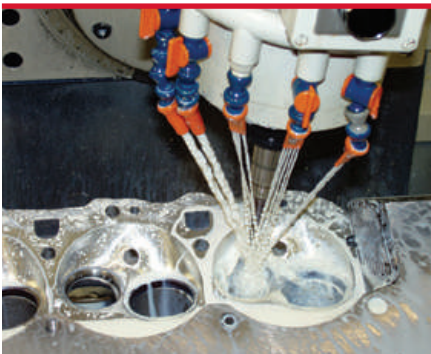

The consistency and accuracy of CNC (Computer Numerical Control) machining makes every CNC ported Dart head virtually identical. Our automated 5-axis machining centers port heads with incredible accuracy - and you get the performance benefits at a very affordable price!

Assemblies include Stainless Steel valves, premium springs, locks, retainers, guide plates and seals.

### RECOMMENDED MANIFOLDS

- 42411000 Single Plane
- 42421000 Single Plane (4500)

### IRON EAGLE 23° 227cc CNC SPECS

Material:	220 BHN Cast Iron
Valve Angle:	23° (stock)
Intake Port Volume:	227cc CNC
Intake Valve:	2.080"
Exhaust Valve:	1.600"
Chamber Volume:	72cc
Plug Type:	Angle

### FLOW DATA @ 28" WATER

LIFT	INTAKE	EXHAUST
.200"	158	123
.300"	209	157
.400"	257	187
.500"	293	206
.600"	302	221
.700"	309	228
.800"	324	235

BILLET

HON

SBF

BBC

LS

SBC

ACCESS

MANIFOLDS

HEADS

BLOCKS

TOP END KITS

SHORT BLOCKS



# 23° 180cc SMALL BLOCK CHEVY CAST ALUMINUM CYLINDER HEADS

## QUICK INFO >>>

Excellent street, strip, oval track, truck or marine performance upgrade. Maximum torque and throttle response from idle to 6,000 RPM. Best for 327-400 cubic inch engines. Works with most standard components.

Dart's SHP (Special High Performance) 23° 180cc cylinder heads provide an affordable option to those looking for the weight savings of an Aluminum head for a street performance engine. The SHP is designed to work with most of the shelf components.

The SHP head's precision cast ports are designed to offer excellent flow and power without the need for CNC porting. Optimized chambers increase combustion efficiency, and multi-angle intake seats and radiused exhaust seats dramatically increase performance. Manganese Bronze valve guides increase the life of the head.

**Heads are sold individually.**

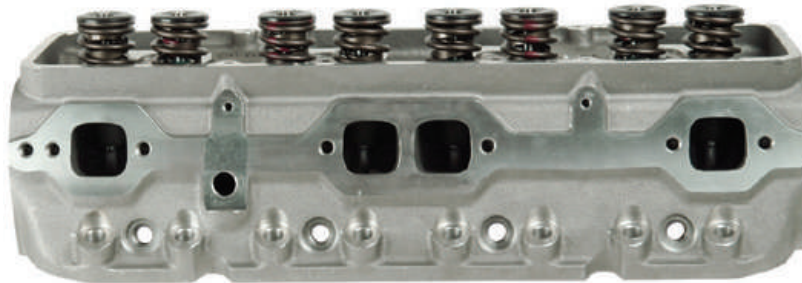

Head parts kit - see page 115.

Uses 3/8" screw-in rocker studs.  
7/16" upgrade available.

## SHP 23° 180cc - ALUMINUM

### 64cc COMBUSTION CHAMBERS

PART NO.	CONFIGURATION FOR USE	MAX. LIFT
127111	Bare Head	
127121	1.250" Single Springs for Hydraulic Flat Tappet Cam	.510"
127122	1.437" Dual Springs for Hydraulic Roller or Solid Flat Tappet Cam	.650"

### 72cc COMBUSTION CHAMBERS

PART NO.	CONFIGURATION FOR USE	MAX. LIFT
127211	Bare Head	
127221	1.250" Single Springs for Hydraulic Flat Tappet Cam	.510"
127222	1.437" Dual Springs for Hydraulic Roller or Solid Flat Tappet Cam	.650"

## RECOMMENDED MANIFOLD

42811000 SHP Dual Plane

## SHP 23° 180cc SPECS

Material:	RMR Cast Aluminum Alloy
Valve Angle:	23° (stock)
Intake Port Volume:	180cc
Intake Valve:	2.020"
Exhaust Valve:	1.600"
Chamber Volume:	64 or 72cc
Plug Type:	Straight

## FLOW DATA @ 28" WATER

LIFT	INTAKE	EXHAUST
.200"	127	103
.300"	175	143
.400"	217	170
.500"	248	186
.600"	250	195



## SHP TOP END KITS ALSO AVAILABLE

- Fully assembled SHP cylinder heads
- Chromed steel valve covers
- Intake manifold
- Gaskets
- Spark plugs
- ARP head bolts

See page 13 for information.





# 23° 200cc SMALL BLOCK CHEVY CAST ALUMINUM CYLINDER HEADS

### QUICK INFO >>>

Street performance, restricted oval track, and marine performance upgrade. Mid-range to 6,500 RPM. Best for 383-434 cubic inch engines.

Dart's SHP (Special High Performance) 23° 200cc cylinder heads provide an affordable option for larger displacement street performance engines. The SHP is designed to work with most off the shelf components.

The SHP head's precision cast ports are designed to offer excellent flow and power without the need for CNC porting. Optimized chambers increase combustion efficiency, and multi-angle intake seats and radiused exhaust seats dramatically increase performance. Manganese Bronze valve guides increase the life of the head.

**Heads are sold individually.**



Head parts kit - see page 115.

Uses 3/8" screw-in rocker studs.  
7/16" upgrade available.

### SHP 23° 200cc - ALUMINUM

#### 64cc COMBUSTION CHAMBERS

PART NO.	CONFIGURATION FOR USE	MAX. LIFT
127311	Bare Head	
127322	1.437" Dual Springs for Hydraulic Roller or Solid Flat Tappet Cam	.650"

#### 72cc COMBUSTION CHAMBERS

PART NO.	CONFIGURATION FOR USE	MAX. LIFT
127411	Bare Head	
127422	1.437" Dual Springs for Hydraulic Roller or Solid Flat Tappet Cam	.650"

### RECOMMENDED MANIFOLD

42811000 SHP Dual Plane

### SHP 23° 200cc SPECS

Material:	RMR Cast Aluminum Alloy
Valve Angle:	23° (stock)
Intake Port Volume:	200cc
Intake Valve:	2.020"
Exhaust Valve:	1.600"
Chamber Volume:	64 or 72cc
Plug Type:	Straight

### FLOW DATA @ 28" WATER

LIFT	INTAKE	EXHAUST
.200"	149	103
.300"	197	143
.400"	237	170
.500"	252	186
.600"	254	195



### SHP SHORT BLOCKS 372, 400 & 427 CUBIC INCH

Simplify engine building and save time with pre-engineered, dyno tested short block combinations from Dart's Special High Performance group.

See page 12 for information.

BILLET

HON

SBF

BBC

LS

SBC

ACCESS

MANIFOLDS

HEADS

BLOCKS

TOP END KITS

SHORT BLOCKS



# 23° SMALL BLOCK CHEVY 220cc CAST ALUMINUM CYLINDER HEADS

## QUICK INFO >>>

*Serious street performance, modified oval track and bracket racing. Mid-range to 7,000 RPM. Best for 400+ cubic inch engines.*

Dart's SHP (Special High Performance) 23° 220cc cylinder heads provide an affordable option for larger displacement street performance engines. The SHP is designed to work with most off the shelf components.

The SHP head's precision cast ports are designed to offer excellent flow and power without the need for CNC porting. Optimized chambers increase combustion efficiency and multi-angle intake seats and radiused exhaust seats dramatically increase performance. Manganese Bronze valve guides increase the life of the head.

**Heads are sold individually.**

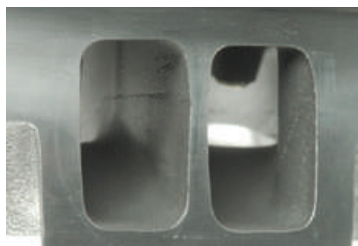

Head parts kit - see page 115.

Uses 3/8" screw-in rocker studs.  
7/16" upgrade available.

Assemblies with 1.550" valve spring  
use +.100" long valves.

## RECOMMENDED MANIFOLD

42411000 Single Plane

## SHP 23° 220cc SPECS

Material:	RMR Cast Aluminum Alloy
Valve Angle:	23° (stock)
Intake Port Volume:	220cc
Intake Valve:	2.050"/2.080"
Exhaust Valve:	1.600"
Chamber Volume:	64 or 72cc
Plug Type:	Straight

## FLOW DATA @ 28" WATER

LIFT	INTAKE	EXHAUST
.200"	127	117
.300"	178	154
.400"	216	179
.500"	249	195
.600"	268	205

## SHP 23° 220cc - ALUMINUM

### 64cc COMBUSTION CHAMBERS - 2.050"/1.600" VALVES

PART NO.	CONFIGURATION FOR USE	MAX. LIFT
127515	Bare Head	
127525	1.437" Dual springs for hydraulic roller or solid flat tappet cam	.650"
127527	1.550" Dual springs for Solid Roller Cam	.700"

### 64cc COMBUSTION CHAMBERS - 2.080"/1.600" VALVES

PART NO.	CONFIGURATION FOR USE	MAX. LIFT
127528	1.550" Dual springs for Solid Roller Cam	.700"

### 72cc COMBUSTION CHAMBERS - 2.050"/1.600" VALVES

PART NO.	CONFIGURATION FOR USE	MAX. LIFT
127615	Bare Head	
127625	1.437" Dual springs for hydraulic roller or solid flat tappet cam	.650"
127627	1.550" Dual springs for Solid Roller Cam	.700"

### 72cc COMBUSTION CHAMBERS - 2.080"/1.600" VALVES

PART NO.	CONFIGURATION FOR USE	MAX. LIFT
127628	1.550" Dual springs for Solid Roller Cam	.700"



# 23° 180cc SMALL BLOCK CHEVY CAST ALUMINUM CYLINDER HEADS

### QUICK INFO >>>

Excellent street, strip, oval track, truck or marine performance upgrade. Maximum torque and throttle response from idle to 6,000 RPM. Best for 327-400 cubic inch engines. Works with most standard components.

Dart's PRO1 23° 180cc Platinum series heads utilize wet flow technology. Independent tests have demonstrated an average 25 horsepower gain over the original trend setting PRO1 design.

These 180cc as cast heads out perform many larger heads in a wide range of applications. Long wearing Bronze valve guides, screw-in studs, multi-angle intake seats and hardened, radiused exhaust seats are standard.

Assemblies include Stainless Steel valves, premium springs, locks, retainers, studs, guide plates and seals.

**Heads are sold individually.**



Head parts kit - see page 115.

Uses 3/8" screw-in rocker studs. 7/16" upgrade available.

Heads with 49cc chambers require special 21.5° pistons.

### PRO1 23° 180cc - ALUMINUM [Straight Plug Heads]

#### 64cc COMBUSTION CHAMBERS

PART NO.	CONFIGURATION FOR USE	MAX. LIFT
11120010P	Bare Head	
11121111P	1.250" Single Springs for Hydraulic Flat Tappet Cam	.510"
11121112P	1.437" Dual Springs for Hydraulic Roller or Solid Flat Tappet Cam	.650"

#### 72cc COMBUSTION CHAMBERS

PART NO.	CONFIGURATION FOR USE	MAX. LIFT
11220010P	Bare Head	
11221111P	1.250" Single Springs for Hydraulic Flat Tappet Cam	.510"
11221112P	1.437" Dual Springs for Hydraulic Roller or Solid Flat Tappet Cam	.650"

### PRO1 23° 180cc - ALUMINUM [Angle Plug Heads]

#### 64cc COMBUSTION CHAMBERS

PART NO.	CONFIGURATION FOR USE	MAX. LIFT
11110010P	Bare Head	
11111111P	1.250" Single Springs for Hydraulic Flat Tappet Cam	.510"
11111112P	1.437" Dual Springs for Hydraulic Roller or Solid Flat Tappet Cam	.650"

#### 72cc COMBUSTION CHAMBERS

PART NO.	CONFIGURATION FOR USE	MAX. LIFT
11210010P	Bare Head	
11211111P	1.250" Single Springs for Hydraulic Flat Tappet Cam	.510"
11211112P	1.437" Dual Springs for Hydraulic Roller or Solid Flat Tappet Cam	.650"

### RECOMMENDED MANIFOLD

**42811000** SHP Dual Plane

### PRO1 23° 180cc SPECS

Material:	RMR Cast Aluminum Alloy
Valve Angle:	23° (stock)
Intake Port Volume:	180cc
Intake Valve:	2.020"
Exhaust Valve:	1.600"
Chamber Volume:	49, 64 or 72cc
Plug Types:	Straight or angle

### FLOW DATA @ 28" WATER

LIFT	INTAKE	EXHAUST
.200"	139	117
.300"	194	154
.400"	233	179
.500"	260	195
.600"	269	205

BILLET

HON

SBF

BBC

LS

SBC

ACCESS

MANIFOLDS

HEADS

BLOCKS

TOP END KITS

SHORT BLOCKS

**23°  
200cc**

# SMALL BLOCK CHEVY CAST ALUMINUM CYLINDER HEADS

**QUICK INFO >>>**

Street performance, restricted oval track, and marine performance upgrade. Mid-range to 6,500 RPM. Best for 383-434 cubic inch engines.

Dart PRO1 23° 200cc Platinum series heads offer increased air flow at high valve lift for large displacement engines. Long wearing Bronze valve guides, screw-in studs, multi-angle intake seats with hardened, radiused exhaust seats are standard. Best of all, our precision cast ports produce outstanding airflow without time consuming porting.

Assemblies include Stainless Steel valves, premium springs, locks, retainers, studs, guide plates and seals.

*Heads are sold individually.*

**PRO1 23° 200cc - ALUMINUM [Straight Plug Heads]**
**64cc COMBUSTION CHAMBERS**

PART NO.	CONFIGURATION FOR USE	MAX. LIFT
11320010P	Bare Head	
11321111P	1.250" Single Springs for Hydraulic Flat Tappet Cam	.510"
11321112P	1.437" Dual Springs for Hydraulic Roller or Solid Flat Tappet Cam	.650"
11321113P	1.550" Dual Springs for Solid Roller Cam	.700"

**72cc COMBUSTION CHAMBERS**

PART NO.	CONFIGURATION FOR USE	MAX. LIFT
11420010P	Bare Head	
11421111P	1.250" Single Springs for Hydraulic Flat Tappet Cam	.510"
11421112P	1.437" Dual Springs for Hydraulic Roller or Solid Flat Tappet Cam	.650"
11421113P	1.550" Dual Springs for Solid Roller Cam	.700"

**PRO1 23° 200cc - ALUMINUM [Angle Plug Heads]**
**49cc COMBUSTION CHAMBERS**

PART NO.	CONFIGURATION FOR USE	MAX. LIFT
11310010PF	Bare Head	
11311111PF	1.250" Single Springs for Hydraulic Flat Tappet Cam	.510"
11311112PF	1.437" Dual Springs for Hydraulic Roller or Solid Flat Tappet Cam	.650"
11311113PF	1.550" Dual Springs for Solid Roller Cam	.700"

**64cc COMBUSTION CHAMBERS**

PART NO.	CONFIGURATION FOR USE	MAX. LIFT
11310010P	Bare Head	
11311111P	1.250" Single Springs for Hydraulic Flat Tappet Cam	.510"
11311112P	1.437" Dual Springs for Hydraulic Roller or Solid Flat Tappet Cam	.650"
11311113P	1.550" Dual Springs for Solid Roller Cam	.700"

**72cc COMBUSTION CHAMBERS**

PART NO.	CONFIGURATION FOR USE	MAX. LIFT
11410010P	Bare Head	
11411111P	1.250" Single Springs for Hydraulic Flat Tappet Cam	.510"
11411112P	1.437" Dual Springs for Hydraulic Roller or Solid Flat Tappet Cam	.650"
11411113P	1.550" Dual Springs for Solid Roller Cam	.700"

Head parts kit - see page 115.

Uses 3/8" screw-in rocker studs.  
7/16" upgrade available.

Assemblies with 1.550" valve spring  
use +.100" long valves.

Heads with 49cc chambers require  
special 21.5° pistons.

**RECOMMENDED MANIFOLD**

42811000 SHP Dual Plane

**PRO1 23° 200cc SPECS**

Material:	RMR Cast Aluminum Alloy
Valve Angle:	23° (stock)
Intake Port Volume:	200cc
Intake Valve:	2.020"
Exhaust Valve:	1.600"
Chamber Volume:	49, 64 or 72cc
Plug Types:	Straight or angle

**FLOW DATA @ 28" WATER**

LIFT	INTAKE	EXHAUST
.200"	139	117
.300"	191	154
.400"	235	179
.500"	266	195
.600"	274	205



# 23° 215cc SMALL BLOCK CHEVY CAST ALUMINUM CYLINDER HEADS

### QUICK INFO >>>

*Serious street performance, modified oval track and bracket racing. Mid-range to 7,000 RPM. Best for 400+ cubic inch engines.*

Dart PRO1 23° 215cc Platinum series heads are for big cubic inch, high RPM applications which favor peak power over low end flexibility.

Long wearing Bronze valve guides, screw-in studs, multi-angle intake seats with hardened, radiused exhaust seats are standard. Best of all, our precision cast ports produce outstanding airflow without time consuming porting.

Assemblies include Stainless Steel valves, premium springs, locks, retainers, studs, guide plates and seals.

**Heads are sold individually.**

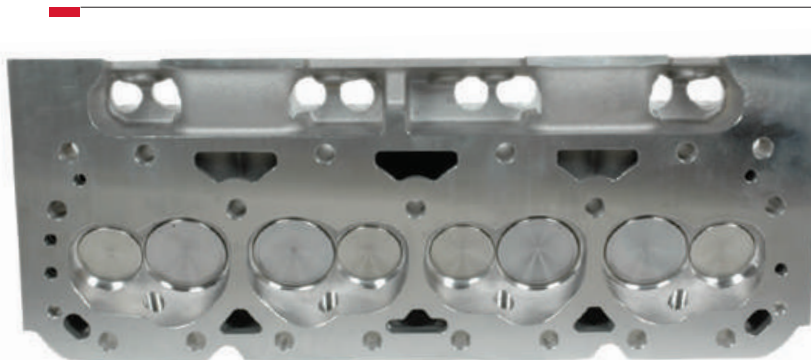

Head parts kit - see page 115.

Uses 3/8" screw-in rocker studs. 7/16" upgrade available.

Assemblies with 1.550" valve spring use +.100" long valves.

Heads with 49cc chambers require special 21.5° pistons.

### PRO1 23° 215cc - ALUMINUM [Straight Plug Heads]

#### 64cc COMBUSTION CHAMBERS

PART NO.	CONFIGURATION FOR USE	MAX. LIFT
11520020P	Bare Head	
11521122P	1.437" Dual Springs for Hydraulic Roller or Solid Flat Tappet Cam	.650"
11521123P	1.550" Dual Springs for Solid Roller Cam	.700"

#### 72cc COMBUSTION CHAMBERS

PART NO.	CONFIGURATION FOR USE	MAX. LIFT
11620020P	Bare Head	
11621122P	1.437" Dual Springs for Hydraulic Roller or Solid Flat Tappet Cam	.650"
11621123P	1.550" Dual Springs for Solid Roller Cam	.700"

### PRO1 23° 215cc - ALUMINUM [Angle Plug Heads]

#### 49cc COMBUSTION CHAMBERS

PART NO.	CONFIGURATION FOR USE	MAX. LIFT
11510020PF	Bare Head	
11511122PF	1.437" Dual Springs for Hydraulic Roller or Solid Flat Tappet Cam	.650"
11511123PF	1.550" Dual Springs for Solid Roller Cam	.700"

#### 64cc COMBUSTION CHAMBERS

PART NO.	CONFIGURATION FOR USE	MAX. LIFT
11510020P	Bare Head	
11511122P	1.437" Dual Springs for Hydraulic Roller or Solid Flat Tappet Cam	.650"
11511123P	1.550" Dual Springs for Solid Roller Cam	.700"

#### 72cc COMBUSTION CHAMBERS

PART NO.	CONFIGURATION FOR USE	MAX. LIFT
11610020P	Bare Head	
11611122P	1.437" Dual Springs for Hydraulic Roller or Solid Flat Tappet Cam	.650"
11611123P	1.550" Dual Springs for Solid Roller Cam	.700"

### RECOMMENDED MANIFOLD

**42411000** Single Plane

### PRO1 23° 215cc SPECS

Material:	RMR Cast Aluminum Alloy
Valve Angle:	23° (stock)
Intake Port Volume:	215cc
Intake Valve:	2.050"
Exhaust Valve:	1.600"
Chamber Volume:	49, 64 or 72cc
Plug Types:	Straight or angle

### FLOW DATA @ 28" WATER

LIFT	INTAKE	EXHAUST
.200"	132	117
.300"	189	154
.400"	232	179
.500"	263	195
.600"	283	205

BILLET

HON

SBF

BBC

LS

SBC

ACCESS

MANIFOLDS

HEADS

BLOCKS

TOP END KITS

SHORT BLOCKS



**23°**  
**230cc**

# SMALL BLOCK CHEVY CAST ALUMINUM CYLINDER HEADS

## QUICK INFO >>>

Maximum performance/full competition, unlimited oval and super classes. 7,000+ RPM, 400+ cubic inch engines.

PRO1 23° 230cc Platinum series heads are intended for maximum effort competition engines with large displacements and very high RPM usage.

Long wearing Bronze valve guides, screw-in studs, multi-angle intake seats with hardened, radiused exhaust seats are standard. Best of all, our precision cast ports produce outstanding airflow without time consuming porting.

Assemblies include Stainless Steel valves, premium springs, locks, retainers, studs, guide plates and seals.

*Heads are sold individually.*

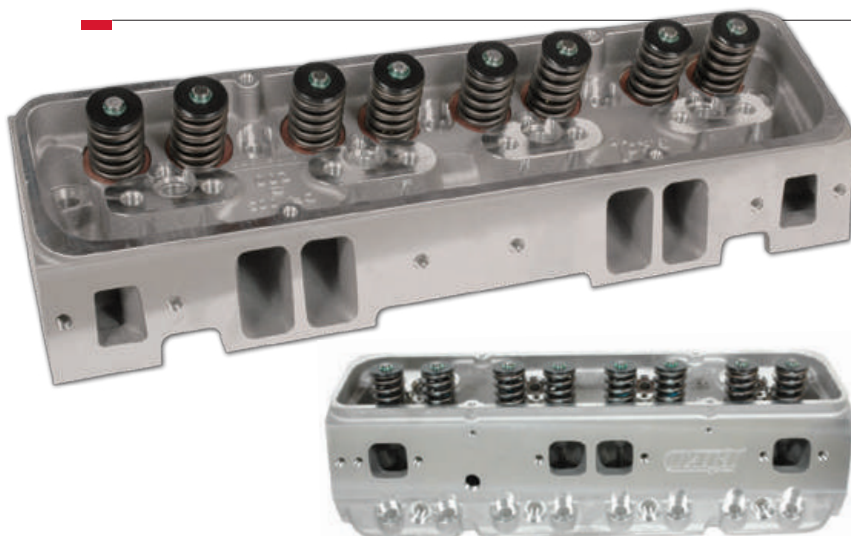

Head parts kit - see page 115.

Uses 3/8" screw-in rocker studs.  
7/16" upgrade available.

Assemblies with 1.550" valve spring  
use +.100" long valves.

Heads with 49cc chambers require  
special 21.5° pistons.

### PRO1 23° 230cc - ALUMINUM [Straight Plug Heads]

#### 64cc COMBUSTION CHAMBERS

PART NO.	CONFIGURATION FOR USE	MAX. LIFT
11720040P	Bare Head	
11721143P	1.550" Dual Springs for Solid Roller Cam	.700"

#### 72cc COMBUSTION CHAMBERS

PART NO.	CONFIGURATION FOR USE	MAX. LIFT
11820040P	Bare Head	
11821143P	1.550" Dual Springs for Solid Roller Cam	.700"

### PRO1 23° 230cc - ALUMINUM [Angle Plug Heads]

#### 49cc COMBUSTION CHAMBERS

PART NO.	CONFIGURATION FOR USE	MAX. LIFT
11710040PF	Bare Head	
11711143PF	1.550" Dual Springs for Solid Roller Cam	.700"

#### 64cc COMBUSTION CHAMBERS

PART NO.	CONFIGURATION FOR USE	MAX. LIFT
11710040P	Bare Head	
11711143P	1.550" Dual Springs for Solid Roller Cam	.700"

#### 72cc COMBUSTION CHAMBERS

PART NO.	CONFIGURATION FOR USE	MAX. LIFT
11810040P	Bare Head	
11811143P	1.550" Dual Springs for Solid Roller Cam	.700"

### RECOMMENDED MANIFOLDS

**42411000** Single Plane  
**42421000** Single Plane (4500)

### PRO1 23° 230cc SPECS

Material:	RMR Cast Aluminum Alloy
Valve Angle:	23° (stock)
Intake Port Volume:	230cc
Intake Valve:	2.080"
Exhaust Valve:	1.600"
Chamber Volume:	49, 64 or 72cc
Plug Types:	Straight or angle

### FLOW DATA @ 28" WATER

LIFT	INTAKE	EXHAUST
.200"	129	117
.300"	184	154
.400"	231	179
.500"	271	195
.600"	296	205
.700"	308	207



**23°  
227cc  
CNC**

# SMALL BLOCK CHEVY CAST ALUMINUM CYLINDER HEADS

### QUICK INFO >>>

Maximum performance/full competition, unlimited oval and super classes. 7,000+ RPM, 400+ cubic inch engines.

Dart PRO1 23° 227cc CNC heads are professional quality competition cylinder heads. We applied the airflow technology developed in our championship winning Pro Stock engine program to produce these state of the art heads.

Every intake port, every exhaust runner, every valve bowl and every combustion chamber is 100% CNC machined on special dedicated PRO1 castings. These heads are ideal for high compression, big cubic inch small blocks and are great for supercharged applications.

Standard valve angle and spacing are retained to allow use of off the shelf pistons and valve train components.

Hardened exhaust seats are compatible with unleaded gasoline. Manganese Bronze valve guides extend cylinder head life.

**Heads are sold individually.**



Head parts kit - see page 115.

Uses 7/16" screw-in rocker studs.

Assembles with 1.550" valve spring use +.100" long valves.

### PRO1 23° 227cc CNC - ALUMINUM (Angle Plug Heads)

#### 66cc COMBUSTION CHAMBERS

PART NO.	CONFIGURATION FOR USE	MAX. LIFT
11970040P	Bare Head	
11971142P	1.437" Dual Springs for Hydraulic Roller or Solid Flat Tappet Cam	.650"
11971143P	1.550" Dual Springs for Solid Roller Cam	.700"



The consistency and accuracy of CNC (Computer Numerical Control) machining makes every CNC ported Dart head virtually identical. Our automated 5-axis machining centers port heads with incredible accuracy, and you get the performance benefits at a very affordable price!

### RECOMMENDED MANIFOLDS

- 42411000 Single Plane
- 42421000 Single Plane (4500)

### PRO1 23° 227cc CNC SPECS

Material:	RMR Cast Aluminum Alloy
Valve Angle:	23° (stock)
Intake Port Volume:	227cc CNC
Intake Valve:	2.080"
Exhaust Valve:	1.600"
Chamber Volume:	66cc
Plug Type:	Angle

### FLOW DATA @ 28" WATER

LIFT	INTAKE	EXHAUST
.200"	158	123
.300"	209	157
.400"	257	187
.500"	293	206
.600"	302	221
.700"	309	228
.800"	324	235

BILLET

HON

SBF

BBC

LS

SBC

ACCESS

MANIFOLDS

HEADS

BLOCKS

TOP END KITS

SHORT BLOCKS



**23°  
245cc  
CNC**

## SMALL BLOCK CHEVY CAST ALUMINUM CYLINDER HEADS

### QUICK INFO >>>

Maximum performance/full competition, unlimited oval and super classes. 7,000+ RPM, 400+ cubic inch engines.

Dart PRO1 23° 245cc CNC heads are professional quality competition cylinder heads. We applied the airflow technology developed in our championship winning Pro Stock engine program to produce these state of the art heads.

Every intake port, every exhaust runner, every valve bowl and every combustion chamber is 100% CNC machined on special dedicated PRO1 castings. These heads are ideal for high compression, big inch small blocks and are great for supercharged or turbocharged applications.

Standard valve angle and spacing are retained to allow use of off the shelf pistons and offset valve train components.

Hardened exhaust seats are compatible with unleaded gasoline. Manganese Bronze valve guides extend cylinder head life.

**Note: Requires use of .150" offset intake rockers.**

**Heads are sold individually.**



Head parts kit - see page 115.

Requires shaft mount rockers.

Assemblies with 1.550" valve spring use +.100" long valves.

### RECOMMENDED MANIFOLD

42411000 Single Plane

### PRO1 23° 245cc CNC SPECS

Material:	RMR Cast Aluminum Alloy
Valve Angle:	23° (stock)
Intake Port Volume:	245cc CNC
Intake Valve:	2.100"
Exhaust Valve:	1.600"
Chamber Volume:	66cc
Plug Type:	Angle

### FLOW DATA @ 28" WATER

LIFT	INTAKE	*A-PORT EXHAUST	*B-PORT EXHAUST
.200"	161	123	116
.300"	219	157	170
.400"	263	187	203
.500"	296	206	225
.600"	316	221	237
.700"	325	228	244
.800"	327	235	251



### PRO1 23° 245cc CNC - ALUMINUM [Angle Plug Heads]

#### 66cc COMBUSTION CHAMBERS

PART NO.	CONFIGURATION FOR USE	MAX. LIFT
11980060P	Bare head	
11981163P	1.550" Dual Springs for Solid Roller Cam	.700"

**\*A-PORT Exhaust is standard.**





# 23° LT1/LT4

# SMALL BLOCK CHEVY GEN II CAST ALUMINUM CYLINDER HEADS

### QUICK INFO >>>

Designed for 1992-1997 LT1 and LT4 small block Chevy engines. 180cc, 200cc and 215cc intake runner sizes cover street performance to serious competition. Gen II reverse flow cooling system and intake manifold flange.

Dart PRO1 Platinum series heads for LT1/LT4 small blocks were developed with Dart's exclusive wet flow technology. Their advanced features include 5-angle intake seats and back cut valves that provide shear points for the fuel to go into suspension as it enters the combustion chamber.

The spark plugs are located as close to the top and center of the combustion chambers as possible, shortening the distance that the flame front must travel and producing a more uniform pressure rise in the cylinder.

Assemblies include Stainless Steel valves, premium springs, locks, retainers, guide plates and seals.

*Heads are sold individually.*



Head parts kit - see page 115.

Uses 3/8" screw-in rocker studs.  
7/16" upgrade available.

Assemblies with 1.550" valve spring  
use +.100" long valves.

### PRO1 23° LT1/LT4 SPECS

Material:	RMR Cast Aluminum Alloy
Valve Angle:	23° (stock)
Intake Port Volume:	180/200/215cc
Intake Valve:	2.020"/2.050"
Exhaust Valve:	1.600"
Chamber Volume:	58cc

### PRO1 180cc FLOW @ 28" WATER

LIFT	INTAKE	EXHAUST
.200"	139	114
.300"	193	145
.400"	231	164
.500"	249	172
.600"	253	174

### PRO1 200cc FLOW @ 28" WATER

LIFT	INTAKE	EXHAUST
.200"	129	114
.300"	185	145
.400"	229	164
.500"	261	172
.600"	263	174

### PRO1 215cc FLOW @ 28" WATER

LIFT	INTAKE	EXHAUST
.200"	127	114
.300"	178	145
.400"	216	164
.500"	249	172
.600"	268	174

### PRO1 23° 180cc - ALUMINUM [LT1/LT4 Heads]

#### 58cc COMBUSTION CHAMBERS

PART NO.	CONFIGURATION FOR USE	MAX. LIFT
11110010L	Bare Head	
11111111L	1.250" Single Springs for Hydraulic Flat Tappet Cam	.510"
11111112L	1.437" Dual Springs for Hydraulic Roller or Solid Flat Tappet Cam	.650"

### PRO1 23° 200cc - ALUMINUM [LT1/LT4 Heads]

#### 58cc COMBUSTION CHAMBERS

PART NO.	CONFIGURATION FOR USE	MAX. LIFT
11310010L	Bare Head	
11311111L	1.250" Single Springs for Hydraulic Flat Tappet Cam	.510"
11311112L	1.437" Dual Springs for Hydraulic Roller or Solid Flat Tappet Cam	.650"
11311113L	1.550" Dual Springs for Solid Roller Cam	.700"

### PRO1 23° 215cc - ALUMINUM [LT1/LT4 Heads]

#### 58cc COMBUSTION CHAMBERS

PART NO.	CONFIGURATION FOR USE	MAX. LIFT
11510020L	Bare Head	
11511122L	1.437" Dual Springs for Hydraulic Roller or Solid Flat Tappet Cam	.650"
11511123L	1.550" Dual Springs for Solid Roller Cam	.700"

BILLET  
HON  
SBF  
BBC  
LS  
SBC  
ACCESS  
MANIFOLDS  
HEADS  
BLOCKS  
TOP END KITS  
SHORT BLOCKS



**18°  
245cc**

# SMALL BLOCK CHEVY CAST ALUMINUM CYLINDER HEADS

## QUICK INFO >>>

Maximum competition, comp/modified drag racing, circle track. Over 7,000 RPM, high compression.

By reducing the valve angle, reshaping the raised intake ports, and optimizing the combustion chambers. We produced a significant increase in both airflow and combustion efficiency and that means more power!

Dart delivers the features that put you ahead of the competition. With the all new PRO1 18° 245cc design we provide our customers the quality, strength and performance you expect from a name like Dart.

*Heads are sold individually.*

## FEATURES

- Cast intake ports with bowl blend.
- CNC exhaust port.
- CNC chambers.
- Assemblies include: Stainless Steel valves, premium springs, locks, retainers and seals. Titanium valve options are available.



Head parts kit - see page 115.

Requires shaft mount rockers and offset lifters.

Requires special pistons.

## RECOMMENDED MANIFOLD

42711000 Single Plane (4150)

## PRO1 18° 245cc SPECS

Material:	RMR Cast Aluminum Alloy
Valve Angle:	18°
Intake Port Volume:	245cc
Intake Valve:	2.150"/2.180"
Exhaust Valve:	1.600"
CNC Chamber Volume:	66cc
Plug Type:	Angle

## FLOW DATA @ 28" WATER

LIFT	INTAKE	EXHAUST
.200"	149	114
.300"	222	160
.400"	280	204
.500"	320	235
.600"	331	246
.700"	337	253

## PRO1 18° 245cc - ALUMINUM

### 66cc COMBUSTION CHAMBERS - 2.150"/1.600" VALVES

PART NO.	CONFIGURATION FOR USE	MAX. LIFT
11992010	Bare Head	
11992113	1.550" Dual springs for Solid Roller Cam	.750"

### 66cc COMBUSTION CHAMBERS - 2.180"/1.600" VALVES

PART NO.	CONFIGURATION FOR USE	MAX. LIFT
11992030	Bare Head	
11992133	1.550" Dual springs for Solid Roller Cam	.750"



**18°**  
**250-272cc**  
**CNC**

# SMALL BLOCK CHEVY CAST ALUMINUM CYLINDER HEADS

### QUICK INFO >>>

Maximum competition, comp/modified drag racing, circle track. Over 7,000 RPM, high compression.

By reducing the valve angle, reshaping the raised intake ports, and optimizing the combustion chambers, we produced a significant increase in both airflow and combustion efficiency - and that means more power!

Dart delivers the features that put you ahead of the competition. We've refined the 18° design to give our customers more versatility, more performance, more reliability, and higher quality.

Assemblies include Stainless Steel valves, premium springs, locks, retainers and seals. Titanium valves are an available option.

**Heads are sold individually.**

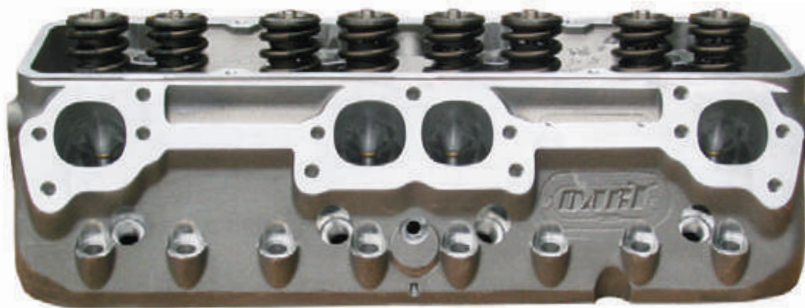
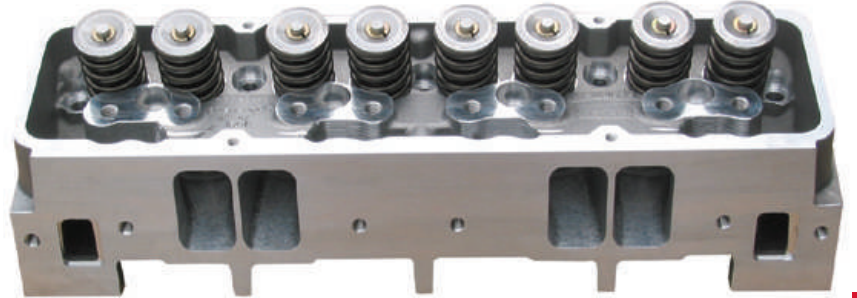

Head parts kit - see page 115.

Requires shaft mount rockers and offset lifters.

Requires special pistons.

### RACE SERIES 18° 250-272cc CNC - ALUMINUM

PART NO.	CONFIGURATION FOR USE	MAX. LIFT
14100000C	Bare Head - No Porting	

#### FULL PORT CNC STD. - 250cc - 2.150"/1.600" VALVES

PART NO.	CONFIGURATION FOR USE	MAX. LIFT
14172010	Bare Head - Full Port	
14172111	1.550" Dual Springs for Solid Roller Cam	.750"

#### FULL PORT CNC STD. - 250cc - 2.180"/1.600" VALVES

PART NO.	CONFIGURATION FOR USE	MAX. LIFT
14172030	Bare Head - Full Port	
14172131	1.550" Dual Springs for Solid Roller Cam	.750"

#### FULL PORT CNC LG. - 272cc - 2.180"/1.600" VALVES

PART NO.	CONFIGURATION FOR USE	MAX. LIFT
14182030	Bare Head - Full Port	
14182131	1.550" Dual Springs for Solid Roller Cam	.750"

### RECOMMENDED MANIFOLD

42711000 Single Plane 4150

### RACE SERIES 18° 250-272cc CNC SPECS

Material:	RMR Cast Aluminum Alloy
Valve Angle:	18°
Intake Port Volume:	250-272cc CNC
Intake Valve:	2.150"/2.180"
Exhaust Valve:	1.600"
Chamber Volume:	66cc w/SS
Plug Type:	Angle

### FLOW DATA @ 28" WATER

LIFT	INTAKE	EXHAUST
.200"	155	118
.300"	225	169
.400"	280	216
.500"	323	242
.600"	347	254
.700"	361	258
.800"	365	260

Figures for Full CNC Port Lg.

BILLET

HON

SBF

BBC

LS

SBC

ACCESS

MANIFOLDS

HEADS

BLOCKS

TOP END KITS

SHORT BLOCKS



**16°  
268cc  
CNC**

# SMALL BLOCK CHEVY CAST ALUMINUM CYLINDER HEADS

## QUICK INFO >>>

Maximum competition, comp/modified drag racing, circle track. Over 7,000 RPM, high compression - low dome.

Dart Race Series 16° 268cc CNC small block heads deliver awesome performance, and work great with nitrous. The shallow valve angle, reshaped and raised intake ports and optimized combustion chambers produce a significant increase in both airflow and combustion efficiency.

It is recommended that you contact a Dart technical representative before placing an order for this item. Detailed information about your planned engine build will help to ensure that you choose the right configuration for your motor and that any special parts and considerations are taken into account.

*Heads are sold individually.*

*Dual exhaust bolt pattern to fit a variety of headers.*



Head parts kit - see page 115.

Requires shaft mount rockers and offset lifters.

Requires special pistons.

Assemblies with 1.550" valve spring use +.600" long valves.

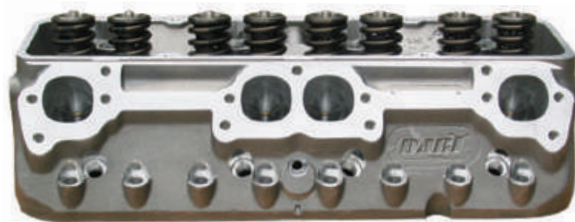

## RECOMMENDED MANIFOLD

42711000 Single Plane 4150

## RACE SERIES 16° 268cc CNC SPECS

Material:	RMR Cast Aluminum Alloy
Valve Angle:	16°
Intake Port Volume:	268cc CNC
Intake Valve:	2.150"/2.180"
Exhaust Valve:	1.600"/1.625"
Chamber Volume:	47cc w/Ti 51cc w/SS
Plug Type:	Angle

## FLOW DATA @ 28" WATER

LIFT	INTAKE	EXHAUST
.200"	158	111
.300"	219	168
.400"	279	217
.500"	324	241
.600"	340	252
.700"	356	257
.800"	363	261
.900"	368	263

## RACE SERIES 16° 268cc CNC - ALUMINUM

PART NO.	CONFIGURATION FOR USE	MAX. LIFT
14200000C	Bare Head - No Porting	

### FULL PORT CNC - 2.150"/1.600" VALVES

PART NO.	CONFIGURATION FOR USE	MAX. LIFT
14272010	Bare Head - Full Port	
14272111	1.550" Dual Springs for Solid Roller Cam	.750"

### FULL PORT CNC - 2.150"/1.625" VALVES

PART NO.	CONFIGURATION FOR USE	MAX. LIFT
14272020	Bare Head - Full Port	
14272121	1.550" Dual Springs for Solid Roller Cam	.750"

### FULL PORT CNC - 2.180"/1.600" VALVES

PART NO.	CONFIGURATION FOR USE	MAX. LIFT
14272030	Bare Head - Full Port	
14272131	1.550" Dual Springs for Solid Roller Cam	.750"

### FULL PORT CNC - 2.180"/1.625" VALVES

PART NO.	CONFIGURATION FOR USE	MAX. LIFT
14272040	Bare Head - Full Port	
14272141	1.550" Dual Springs for Solid Roller Cam	.750"



**15°  
284cc  
CNC**

# SMALL BLOCK CHEVY CAST ALUMINUM CYLINDER HEADS

### QUICK INFO >>>

Maximum competition, comp/modified drag racing, circle track. Over 7,000 RPM, high compression - low dome.

Dart Race Series 15° 284cc CNC small block heads deliver awesome performance. The shallow valve angle, reshaped raised intake ports and optimized combustion chambers produce a significant increase in both airflow and combustion efficiency.

It is recommended that you contact a Dart technical representative before placing an order for this item. Detailed information about your planned engine build will help to ensure that you choose the right configuration for your motor and that any special parts and considerations are taken into account.

**Heads are sold individually.**



**DUAL EXHAUST BOLT PATTERNS TO FIT A VARIETY OF HEADERS.**

### RACE SERIES 15° 284cc CNC - ALUMINUM

PART NO.	CONFIGURATION FOR USE	MAX. LIFT
14300000C	Bare Head - No Porting	

#### FULL PORT CNC - 2.150"/1.600" VALVES

PART NO.	CONFIGURATION FOR USE	MAX. LIFT
14372010	Bare Head - Full Port	
14372111	1.550" Dual Springs for Solid Roller Cam	.750"

#### FULL PORT CNC - 2.180"/1.600" VALVES

PART NO.	CONFIGURATION FOR USE	MAX. LIFT
14372030	Bare Head - Full Port	
14372131	1.550" Dual Springs for Solid Roller Cam	.750"

#### FULL PORT CNC - 2.180"/1.625" VALVES

PART NO.	CONFIGURATION FOR USE	MAX. LIFT
14372040	Bare Head - Full Port	
14372141	1.550" Dual Springs for Solid Roller Cam	.750"

### RECOMMENDED MANIFOLD

42711000 Single Plane 4150

### RACE SERIES 15° 284cc CNC SPECS

Material:	RMR Cast Aluminum Alloy
Valve Angle:	15°
Intake Port Volume:	284cc CNC
Intake Valve:	2.150"/2.180"
Exhaust Valve:	.600"/1.625"
Chamber Volume:	48cc w/Ti
Plug Type:	Angle

### FLOW DATA @ 28" WATER

LIFT	INTAKE	EXHAUST
.200"	160	128
.300"	232	175
.400"	293	214
.500"	333	242
.600"	357	256
.700"	369	265
.800"	372	266

Head parts kit - see page 115.

Requires shaft mount rockers and offset lifters.

Requires special pistons.

Assemblies with 1.550" valve spring use +.600" long valves.

BILLET

HON

SBF

BBC

LS

SBC

ACCESS

MANIFOLDS

HEADS

BLOCKS

TOP END KITS

SHORT BLOCKS



# 12.5° 265cc CNC OVAL PORT

# SMALL BLOCK CHEVY CAST ALUMINUM CYLINDER HEADS

### QUICK INFO >>>

Maximum competition, Specifically designed for circle track racing, Super Late Model or Sprint. Over 7,000 RPM, high compression - low dome.

Dart Race Series 12.5° 265cc CNC oval port heads offer outstanding performance in a raised runner style casting. By reducing the valve angle, reshaping the raised intake ports and optimizing the combustion chambers, we produced a significant increase in both airflow and combustion efficiency.

It is recommended that you contact a Dart technical representative before placing an order for this item. Detailed information about your planned engine build will help to ensure that you choose the right configuration for your motor and that any special parts and considerations are taken into account.

**Heads are sold individually.**

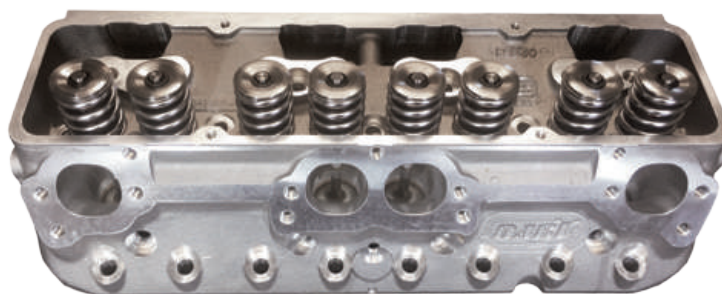
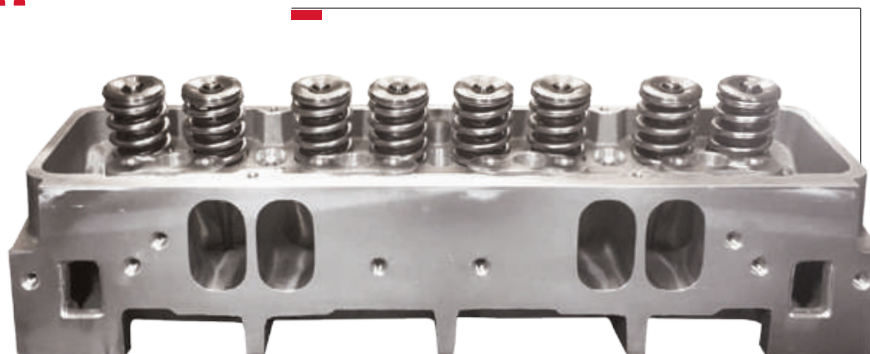

Head parts kit - see page 115.

Requires shaft mount rockers and offset lifters.

Requires special pistons.

Assembles with 1.550" valve spring use +.600" long valves.

### RECOMMENDED MANIFOLD

**42711005** Single Plane 4150 (Filed core)

### RACE SERIES 12.5° 265cc CNC SPECS

Material:	RMR Cast Aluminum Alloy
Valve Angle:	12.5°
Intake Port Volume:	265cc CNC
Intake Valve:	2.150"
Exhaust Valve:	1.600"
Chamber Volume:	36cc
Plug Type:	Angle

### FLOW DATA @ 28" WATER

LIFT	INTAKE	EXHAUST
.200"	145	109
.300"	214	158
.400"	279	203
.500"	306	234
.600"	344	256
.700"	347	265

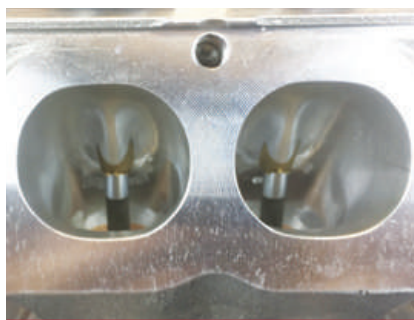
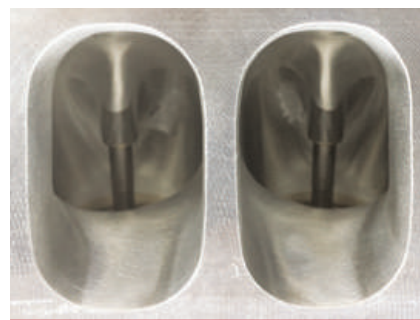

### RACE SERIES 12.5° 265cc CNC - ALUMINUM [OVAL PORT]

#### FULL PORT CNC - 2.150"/1.600" VALVES

PART NO.	CONFIGURATION FOR USE	MAX. LIFT
14462010	Bare Head	
14462111	1.550" Dual Springs for Solid Roller Cam	.750"



**12.5°  
296cc  
CNC**

# SMALL BLOCK CHEVY CAST ALUMINUM CYLINDER HEADS

### QUICK INFO >>>

Maximum competition, comp/modified drag racing, circle track. Over 7,000 RPM, high compression - low dome.

Dart Race Series 12.5° 296cc CNC heads offer outstanding performance in a raised runner style casting. By reducing the valve angle, re-shaping the raised intake ports and optimizing the combustion chambers, we produced a significant increase in both airflow and combustion efficiency.

It is recommended that you contact a Dart technical representative before placing an order for this item. Detailed information about your planned engine build will help to ensure that you choose the right configuration for your motor and that any special parts and considerations are taken into account.

**Heads are sold individually.**

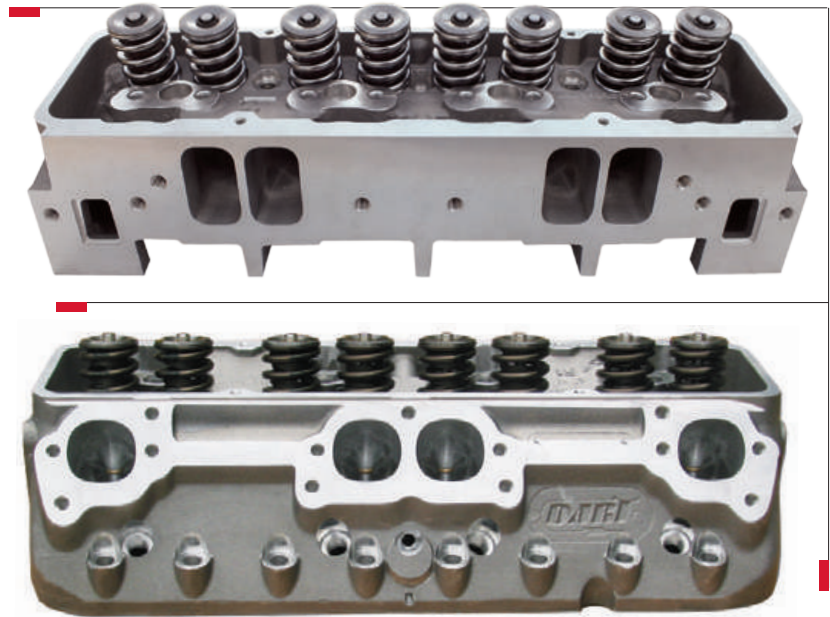

Head parts kit - see page 115.

Requires shaft mount rockers and offset lifters.

Requires special pistons.

Assemblies with 1.550" valve spring use +.600" long valves.

### RECOMMENDED MANIFOLD

42711000 Single Plane 4150

### RACE SERIES 12.5° 296cc CNC SPECS

Material: RMR Cast Aluminum Alloy  
 Valve Angle: 12.5°  
 Intake Port Volume: 296cc CNC  
 Intake Valve: 2.150"/2.180"  
 Exhaust Valve: 1.600"  
 Chamber Volume: 38cc w/Ti  
 Plug Type: Angle

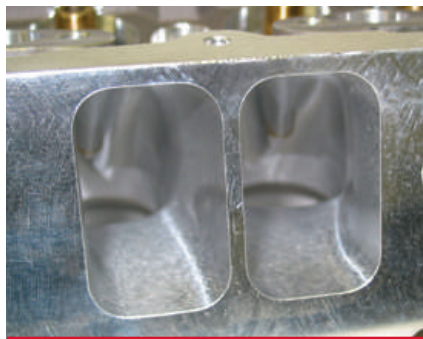

### RACE SERIES 12.5° 296cc CNC - ALUMINUM

PART NO.	CONFIGURATION FOR USE	MAX. LIFT
14400000C	Bare Head - No Porting	

### FULL PORT CNC - 2.150"/1.600" VALVES

PART NO.	CONFIGURATION FOR USE	MAX. LIFT
14472010	Bare Head	
14472111	1.550" Dual Springs for Solid Roller Cam	.750"

### FULL PORT CNC - 2.180"/1.600" VALVES

PART NO.	CONFIGURATION FOR USE	MAX. LIFT
14482030	Bare Head	
14482131	1.550" Dual Springs for Solid Roller Cam	.750"

### FLOW DATA @ 28" WATER

LIFT	INTAKE	EXHAUST
.200"	157	116
.300"	231	162
.400"	287	206
.500"	340	251
.600"	367	271
.700"	377	279
.800"	385	281
.900"	386	283

BILLET

HON

SBF

BBC

LS

SBC

ACCESS

MANIFOLDS

HEADS

BLOCKS

TOP END KITS

SHORT BLOCKS



# 11° LITTLE CHIEF CNC

## SMALL BLOCK CHEVY CAST ALUMINUM CYLINDER HEADS

### QUICK INFO >>>

Maximum competition, off-road trucks, comp/modified drag racing, circle track. 8,000+ RPM, alcohol or nitrous, turbo, supercharger.

Dart's 11° Little Chief CNC is the ultimate small block cylinder head. Designed with Pro Stock style oval ports, big block style canted valves and "semi-hemi" style combustion chambers, the Little Chief is a radical departure from traditional small block heads.

The huge flow resulting from the 11° valve angle and splayed valve layout combined with spread oval intake ports, raised runners and highly efficient combustion chambers deliver amazing power!

It is recommended that you contact a Dart technical representative before placing an order for this item. Detailed information about your planned engine build will help to ensure that you choose the right configuration for your motor and that any special parts and considerations are taken into account.

*Heads are sold individually.*

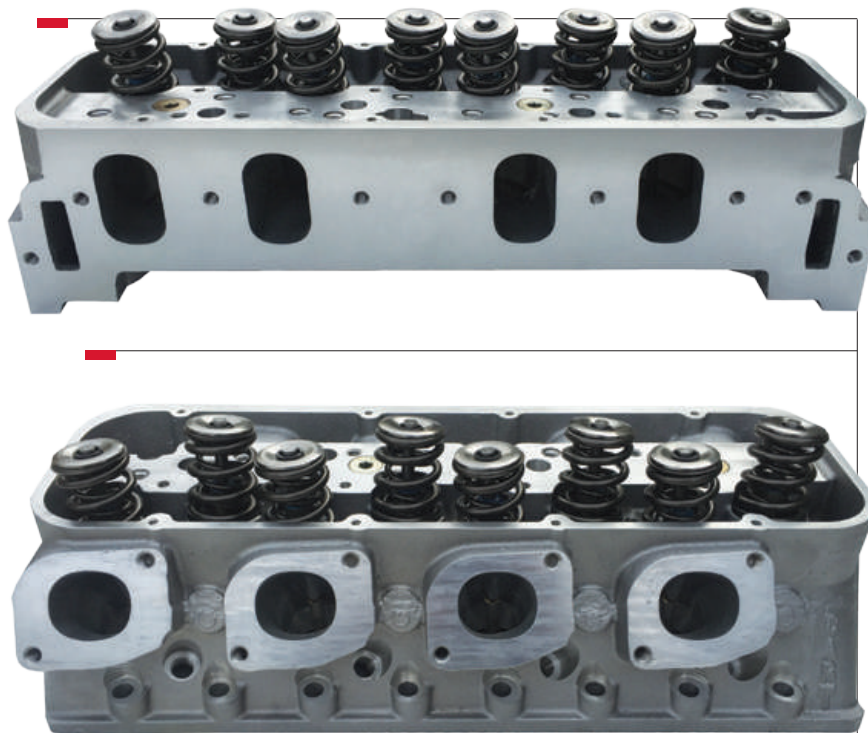

### LITTLE CHIEF 11° CNC SPECS

Material:	RMR Cast Aluminum Alloy
Valve Angle:	Splayed 11°
Intake Port Volume:	275-330cc CNC
Intake Valve:	2.180"/2.230"
Exhaust Valve:	1.550"
Chamber Volume:	34, 36 or 50cc

### RACE SERIES LITTLE CHIEF 11° CNC - ALUMINUM

PART NO.	INTAKE PORT	CHAMBER VOL.	VALVES	SPRINGS BORE	CYL	NOTES
14600000	Bare Casting - No CNC Porting					
14600000N	Bare Casting - No CNC Porting - Machined for Down Nozzles					
14672050	275cc	36cc	2.180"/1.550"	Bare	4.155"	Full Port - Bare
14672156	275cc	36cc	2.180"/1.550"	1.625"D	4.155"	Full Port - Assembled
14772060	315cc	34cc	2.230"/1.550"	Bare	4.155"	Full Port - Bare
14772166	315cc	34cc	2.230"/1.550"	1.625"D	4.155"	Full Port - Assembled
14773060	315cc	50cc	2.230"/1.550"	Bare	4.155"	Full Port - Bare
14872070	330cc	36cc	2.230"/1.550"	Bare	4.155"	Full Port - Bare
14873070	330cc	50cc	2.230"/1.550"	Bare	4.155"	Full Port - Bare

### FLOW DATA @ 28" WATER

LIFT	INTAKE	EXHAUST
.200"	143	138
.300"	233	186
.400"	304	241
.500"	360	266
.600"	393	274
.700"	405	278
.800"	418	280
.900"	425	282
1.000"	431	282

*Figures for Full Port 330cc*





# 9° CASTINGS SMALL BLOCK CHEVY CAST ALUMINUM CYLINDER HEADS

### QUICK INFO >>>

Maximum competition, competition/modified drag racing, circle track. Desert/endurance racing, Over 7,000 RPM, high compression – low dome.

Dart 9° c-core heads offer the maximum performance for cylinder head porters and machine shops with CNC capability.

These are the ultimate castings for head porters. The redesigned casting has been optimized for CNC porting. Features include: raised intake and exhaust port locations, optimized spark plug locations, optimized deck thickness, expanded water jacket capacity, bosses for down nozzles and revised valve cover rail to clear long ratio rocker geometry. Provisions for extra head bolts have been added to each end, making for an improved seal. Available in standard 4.400" or 4.500" spread bore spacing.

It is recommended that you contact a Dart technical representative before placing an order for this item. Detailed information about your planned engine build will help to ensure that you choose the right configuration for your motor and that any special parts and considerations are taken into account.

**Heads are sold individually.**

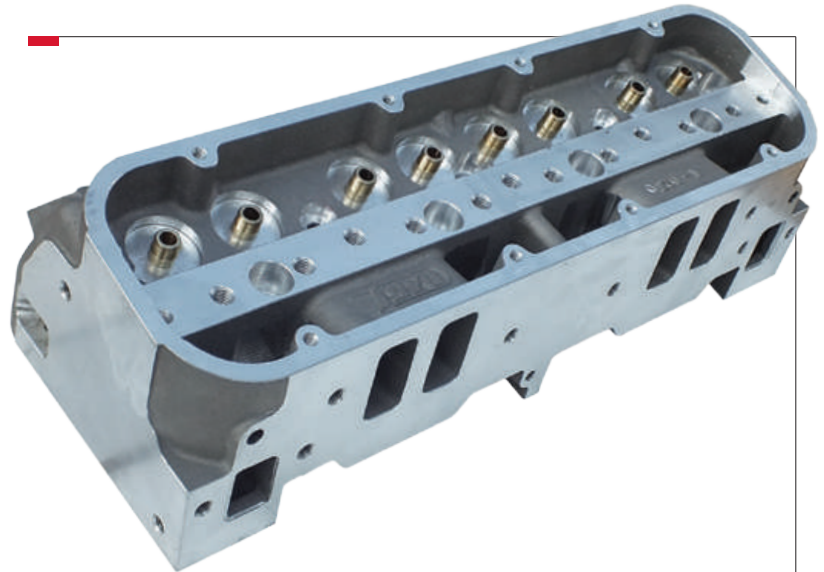

See SBC 9° Manifold on page 48.

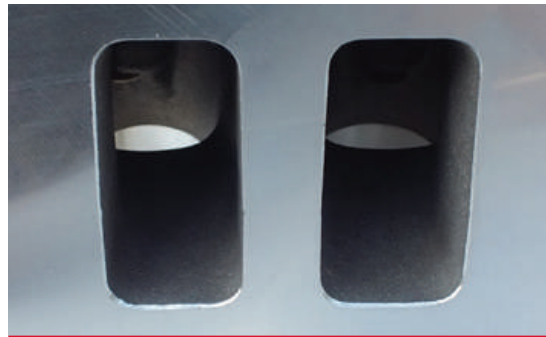

### RACE SERIES 9° - ALUMINUM

PART NO.	CONFIGURATION FOR USE	BORE SPACING
1450000C	SBC 9°	4.400" bore space casting
1450001C	SBC 9°	4.500" bore space casting

### RECOMMENDED MANIFOLDS

42811100	(4150/4.400"/9°)
42812200	(4150/4.500"/Spread Bore 9°)
42812100	(4150/4.400"/9°)
42822000	(4150/4.500"/Spread Bore 9°)

### RACE SERIES 9° SPECS

Material:	RMR Cast Aluminum Alloy
Valve Angle:	9°
Intake Port Volume:	C-Core for Porting Only
Intake Valve:	N/A
Exhaust Valve:	N/A
Chamber Volume:	N/A
Plug Type:	Angle

BILLET

HON

SBF

BBC

LS

SBC

ACCESS

MANIFOLDS

HEADS

BLOCKS

TOP END KITS

SHORT BLOCKS

# SMALL BLOCK CHEVY INTAKE MANIFOLDS

An engine's cylinder heads and intake manifold must work together as an integrated system to produce maximum performance. The intake charge should make a seamless transition from the manifold runners to the cylinder head ports. Dart intake manifolds incorporate sophisticated wet flow technology developed on successful oval track and drag racing engines. We've optimized the port shape, the plenum volumes, and the runner angle for each application. Dart manifolds are designed to make engine building easier. For example, our small block manifolds have provisions for "four corner" and center cooling. Most Dart manifolds have bosses for nitrous injectors.

## DUAL PLANE SHP

PART NO	USE WITH HEADS	PORT LOCATION	DECK	CARB
42811000	SBC Iron/SHP/PRO 1	Standard	Std.	4150

## SINGLE PLANE

PART NO	USE WITH HEADS	PORT LOCATION	DECK	CARB
42411000	SBC Iron/PRO 1	Standard	Std.	4150
42412000	SBC Iron/PRO 1	Standard	9.325"	4150
42421000	SBC Iron/PRO 1	Standard	Std.	4500
42422000	SBC Iron/PRO 1	Standard	9.325"	4500
42711000	18°/15°/12.5°	Raised	9.025"	4150
42711005	12.5°/Oval Port	File Core	9.025"	4150

## SINGLE PLANE 220

PART NO	USE WITH HEADS	PORT LOCATION	DECK	CARB
42311000	SBC 220	Standard	Std.	4150
42312000	SBC 220	Standard	9.325"	4150
42321000	SBC 220	Standard	Std.	4500
42322000	SBC 220	Standard	9.325"	4500
42511000	SBC 220 RR	Raised Runner	Std.	4150
42512000	SBC 220 RR	Raised Runner	9.325"	4150
42521000	SBC 220 RR	Raised Runner	Std.	4500
42522000	SBC 220 RR	Raised Runner	9.325"	4500

## 9° 2-PIECE MANIFOLDS

PART NO	USE WITH HEADS	PORT LOCATION	DECK	CARB
42811100	9° 4.400" Bore Space	Raised	9.025"	4150
42811200	9° 4.500" Bore Space	Raised	9.025"	4150
42812100	9° 4.400" Bore Space	Raised	9.325"	4150
42812200	9° 4.500" Bore Space	Raised	9.325"	4150

*\*Note - requires aftermarket valley tray.*

## INTAKE MANIFOLD SPACER KITS

PART NO.	DESCRIPTION
62210002	SBC Manifold spacers, tall deck (9.325") block, 23° heads (¼" thick)
62210003	SBC Manifold spacers, tall deck (9.500") block, 23° heads (½" thick)
62210004	SBC Manifold spacers, tall deck (9.325") block, 18° heads (¼" thick)
62210008	SBC Manifold spacers, tall deck (9.500") block, 18° heads (½" thick)

42811000  
SHP



42411000  
SBC 4150



42421000  
SBC 4500



42811100  
SBC 9°

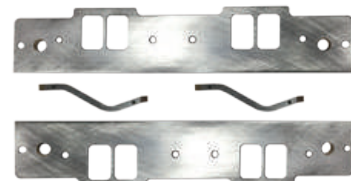

*Dart manifolds may be ordered with CNC porting options. Super Mod (gasket match) or Super Mod Complete, which includes hand blending and plenum work. Full port options are available.*



# SMALL BLOCK CHEVY ACCESSORIES

## VALVE COVERS

Our extra tall valve covers are designed to clear racing valve trains and stud girdles, and to specifically fit Dart cylinder heads.

Chrome plated stamped steel valve covers have a breather hole and baffle with an embossed Dart logo. Cast Aluminum valve covers feature machined gasket surfaces to prevent messy oil leaks. The raised Dart logo stands out with a contrasting machined finish. Our new inverted flange valve covers provide extra room for long ratio rockers and over sized springs.

## VALVE COVERS

### SMALL BLOCK CHEVY

PART NO.	DESCRIPTION	FITS
68000050	Stamped Steel Valve Cover Set	Dart SBC
68000015	Cast Aluminum Valve Cover Set	Dart SBC

### LITTLE CHIEF

PART NO.	DESCRIPTION	FITS
68000070	Cast Aluminum Valve Cover Set	Dart Little Chief

*Note: All valve covers include gaskets and fasteners.*

SBC Stamped Steel



SBC Inverted Flange



Little Chief



## VALVE TRAIN STABILIZERS

Valve train stabilizers, also known as "stud girdles" improve the performance and reliability of engines equipped with stud mounted rocker arms. Extra long adjusting nuts are tightly clamped between rigid Aluminum bars that prevent stud deflection under high loads. The valve motion more closely follows the cam profile, producing more power and reducing breakage. Unlike "universal" girdles, these valve train stabilizers are designed to fit the specific valve locations, valve angles, and valve lengths in Dart cylinder heads. Kits include hardened polylock adjusting nuts.



## VALVE TRAIN STABILIZERS

PART NO.	DESCRIPTION	FITS
64110002	Valve Train Stabilizer w/ 3/8" polylocks	Dart SBC
64110003	Valve Train Stabilizer w/ 7/16" polylocks	Dart SBC

## HEAD PARTS KITS

Dart parts kits include everything you need to assemble a cylinder head: Stainless Steel valves, springs, locks, retainers, seals, studs, and guide plates. These kits contain the same high quality components we use in our cylinder head assemblies. Each kit does one cylinder head. For both Iron and Aluminum heads.

### SMALL BLOCK HEAD PARTS KITS (INCLUDES STEEL RETAINERS)

PART NO.	INT.	EXH.	SPRING
28111000	2.020"	1.600"	1.250" single
28112000	2.020"	1.600"	1.437" double
28211000	2.050"	1.600"	1.250" single
28212000	2.050"	1.600"	1.437" double
28223000	2.050"	1.600"	1.550" double
28423000	2.080"	1.600"	1.550" double



### SBC ONE PIECE STAMPED GUIDE PLATES

PART NO.	DESCRIPTION
27001110	Stamped guide plate 5/16" each (4 required per head)

### SBC ADJUSTABLE GUIDE PLATES

PART NO.	DESCRIPTION
27001410	Adjustable guide plate 5/16" each
27001410-4	Adjustable guide plates 5/16" Set of 4 (for one head)

BILLET

HON

SBF

BBC

LS

SBC

ACCESS

MANIFOLDS

HEADS

BLOCKS

TOP END KITS

SHORT BLOCKS

# SHP LS NEXT

SPECIAL HIGH PERFORMANCE

## GEN III - SHORT BLOCKS CAST IRON BLOCKS

FULL SKIRT DESIGN

### QUICK INFO >>>

Professionally built short blocks with brand new premium components. Street performance and Sportsman racing.

### 427 CUBIC INCHES

Simplify engine building and save time with pre-engineered, dyno tested short block combinations from Dart's SHP (Special High Performance) group.

These quality component packages are designed to allow the user to build more powerful and durable engines at a very affordable cost.

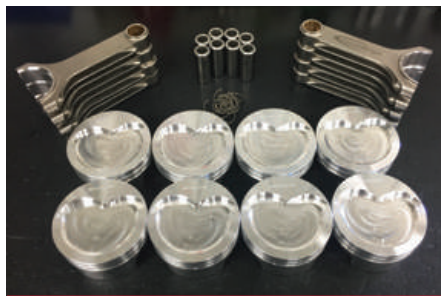
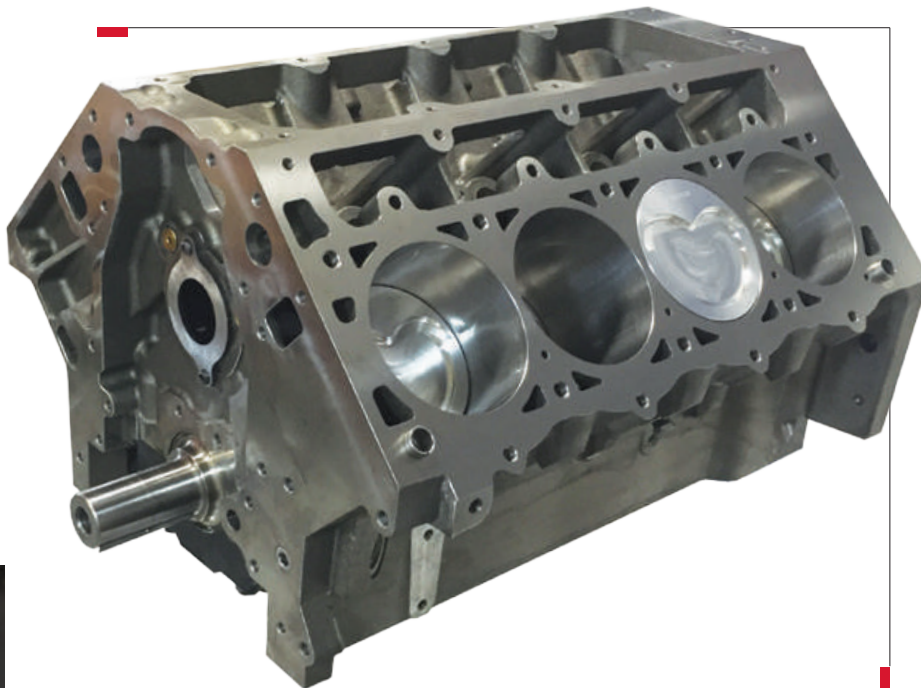

### 427 CUBIC INCH SHORT BLOCK [6CW]

LS3/LS7 Compatible  
Internally Balanced  
Special High Performance LS NEXT Dart Block  
4.125" Bore x 4.000" Stroke  
Plate Honed Cylinders  
Forged 4340 Steel Crankshaft (6 Counterweight)  
Forged 4340 H-Beam Rods - 7/16" ARP 2000 Bolts  
Forged Flat Top Pistons w/ Full Floating Pin  
MAHLE Rings  
Clevite Bearings  
Coated Cam Bearings  
24 Tooth or 58 Tooth Reluctor

*Optional LS3/LS7 Flat Top or Dished Pistons*

**Flat Top:**

**CR 11.3:1 w/68cc chamber & .053" gasket.**

**Dish:**

**CR 9.2:1 w/68cc chamber & .053" gasket.**

### 427 CUBIC INCH SHORT BLOCK [8CW]

LS3/LS7 Compatible  
Internally Balanced  
Special High Performance LS NEXT Dart Block  
4.125" Bore x 4.000" Stroke  
Plate Honed Cylinders  
Billet 4340 Steel Crankshaft (8 Counterweight)  
Forged 4340 H-Beam Rods - 7/16" ARP 2000 Bolts  
Forged Flat Top Pistons w/ Full Floating Pin  
MAHLE Rings  
Clevite Bearings  
Coated Cam Bearings  
24 Tooth or 58 Tooth Reluctor

*Optional LS3/LS7 Flat Top or Dished Pistons*

**Flat Top:**

**CR 11.3:1 w/68cc chamber & .053" gasket.**

**Dish:**

**CR 9.2:1 w/68cc chamber & .053" gasket.**



### RECOMMENDED HEADS

PRO1 LS 15° 280cc (LS3) - See page 60

PRO1 LS 12° 285cc CNC (LS7) - See page 61

### SHP LS NEXT SHORT BLOCKS [FULLY SKIRTED]

PART NO.	DESCRIPTION	CRANK	PISTONS	RODS	STROKE	BORE
03424272	427 SHP (LS3/LS7)	Forged (6CW)	Forged	H-Beam	4.000"	4.125"
03484272	427 SHP (LS3/LS7)	Billet (8CW)	Forged	H-Beam	4.000"	4.125"

BILLET

HON

SBF

BBC

LS

SBC

ACCESS

MANIFOLDS

HEADS

BLOCKS

TOP END KITS

SHORT BLOCKS



# LSNEXT

## GEN III CAST IRON BLOCKS

FULL SKIRT DESIGN

### QUICK INFO >>>

*Designed for high performance and medium duty applications, the SHP LS Next Block is the ideal starting point for hot rodders, drag racers, circle track competitors, off-roaders, and high performance marine enthusiasts.*

### FEATURES

- Dart priority main oiling system with provisions for stock oil filter mounting.
- Accepts factory and aftermarket oil pans.
- Siamesed cylinder bores with thick walls.
- Cylinder barrels extended .375" at the bottom of the bores.
- Thick decks ensure reliable head gasket seal.
- Blind head bolt holes available in 7/16" or 1/2".
- 6-bolt per cylinder capability.
- Scalloped water jackets increase flow around cylinders for better cooling.
- Clearanced up to 4.100" stroke w/ steel rods.
- Clearanced for center counterweighted crankshafts.
- Splayed outer bolts on middle main bearing caps.
- Provisions for LSX roller lifters and cam.
- Uses OE front and rear covers.
- All OE bolt holes for starter, water pump, etc.
- Windage trays.
- Parts kit included (PN: 32000018).

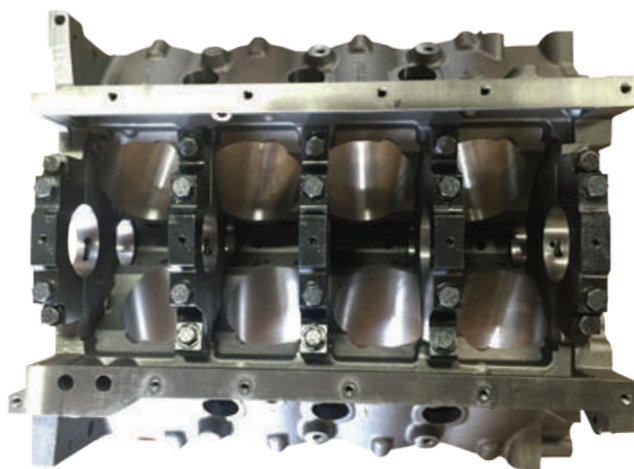
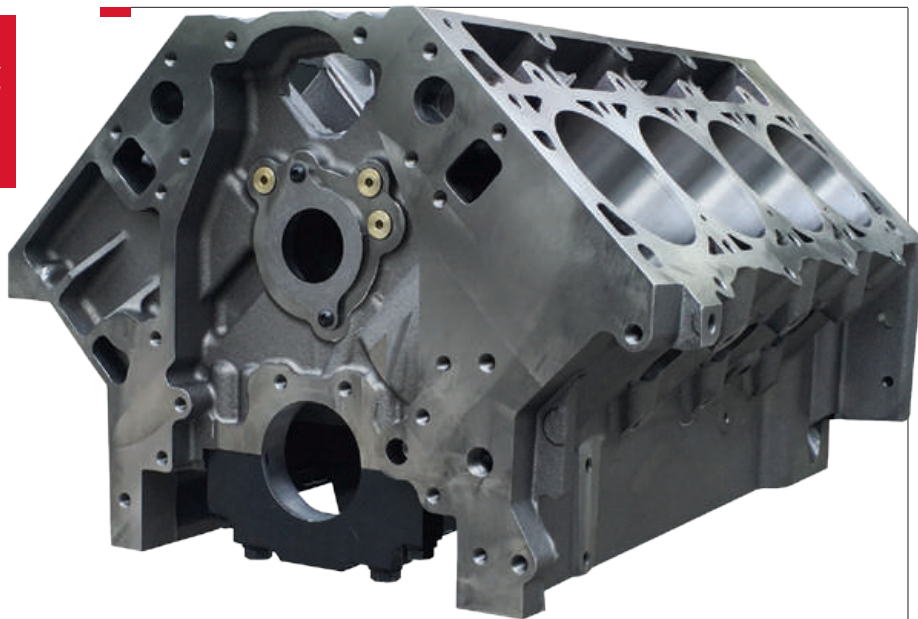

### SHP LS NEXT - GEN III - IRON [FULLY SKIRTED]

PART NO.	DESCRIPTION	REAR SEAL	CAPS	MAINS	DECK	BORE
31867111	LS Next SHP	STD	Steel	STD	9.240"	4.000"
31867211	LS Next SHP	STD	Steel	STD	9.240"	4.125"

### SHP LS NEXT SPECS

Material:	Class 30 Grey Iron
Deck Height:	9.240" (stock)
Cylinder Bores:	4.000" up to 4.185" (max)
Main Bearings Size:	Stock LS
Main Caps:	Steel 4-bolt 1-5
Cam Location:	Stock 55mm
Lifter Bores:	Stock .842" dia.

BILLET

HON

SBF

BBC

LS

SBC

ACCESS

MANIFOLDS

HEADS

BLOCKS

TOP END KITS

SHORT BLOCKS



# LS NEXT PRO

## GEN III CAST IRON BLOCKS

FULL SKIRT DESIGN

**NEW**

### QUICK INFO >>>

Designed for high performance and heavy duty applications, the SHP LS Next PRO is the NEXT-LEVEL PERFORMANCE block for hot rodders, drag racers, circle track competitors, off-roaders, and high performance marine enthusiasts.

### FEATURES

- Superior strength 220 BHN Cast Iron.
- Steel 4-bolt main caps with upgraded ARP main studs.
- Lifter oil crossover with restrictor provision.
- 6-bolt per cylinder capability.
- 4.000" up to 4.185" bore.
- Factory oil filter provision.
- Clearanced for center counterweighted crankshafts.
- Full skirt design.
- Priority main oiling.
- Siamese cylinder bores.
- Thick decks ensure reliable head gasket seal.
- Parts kit included (PN: 32000018 - see page 115).

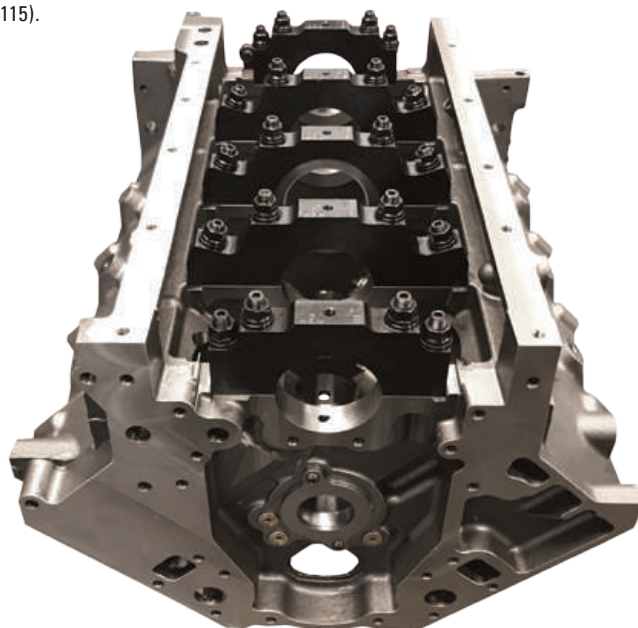

### SHP LS NEXT PRO - GEN III - CAST IRON [FULLY SKIRTED]

PART NO.	DESCRIPTION	REAR SEAL	CAPS	MAINS	DECK	BORE
31867112	LS Next SHP PRO	STD	Steel	STD	9.240"	4.000"
31867212	LS Next SHP PRO	STD	Steel	STD	9.240"	4.125"

### SHP LS NEXT PRO SPECS

Material:	220 BHN Cast Iron
Deck Height:	9.240" (stock)
Cylinder Bores:	4.000" up to 4.185" (max)
Main Bearings Size:	Stock LS
Main Caps:	Steel
	4-bolt 1-5
Cam Location:	Stock 55mm
Lifter Bores:	Stock .842" dia.

# LS NEXT

## GEN III CAST IRON BLOCKS

### QUICK INFO >>>

Designed from a clean slate approach the LS Next Iron block has addressed the shortcomings of the LS platform and is the ideal candidate for hot rodders, drag racers, circle track competitors, off-roaders, and high performance marine enthusiasts.

By utilizing conventional style main caps and oil pans with LS rotating assemblies and related components, Dart has addressed the windage and oil control problems which result from the factory LS engine's separated crankcase bays.

### FEATURES

- Priority main oiling system with two lifter crossover and restrictor provisions.
- Siamesed cylinder bores with extra thick walls.
- Cylinder barrels extended .375" at the bottom.
- Extra thick decks ensure reliable head gasket seal.
- Blind head bolt holes available in 7/16" or 1/2".
- Scalloped water jackets increase flow around cylinders for better cooling.
- Clearance for 4.100" stroke w/ steel rods.
- MUST BE clearanced for center counterweighted crankshafts.
- Splayed outer bolts on middle main bearing caps.
- LS style motor mounts.
- Provisions for OE stock roller lifters and cam.
- Uses stock timing covers and stock rear cover.
- All OE bolt holes for starter, water pump, etc.
- Driver or passenger side starter mounts.
- Parts kit sold separately (PN: 32000016 - see page 115).



### LS NEXT OIL PAN RAIL SPACERS

PART NO.	DESCRIPTION
62230001	LS Next Oil Pan Rail Spacers w/ power steering, AC & oil dipstick provision.

### LS NEXT - GEN III - IRON [RACE BLOCK]

PART NO.	DESCRIPTION	REAR SEAL	CAPS	MAINS	DECK	BORE
31837111	LS Next Iron	STD	Steel	STD	9.240"	4.000"
31837211	LS Next Iron	STD	Steel	STD	9.240"	4.125"
31837121	LS Next Iron	STD	Steel	STD	9.450"	4.000"
31837221	LS Next Iron	STD	Steel	STD	9.450"	4.125"

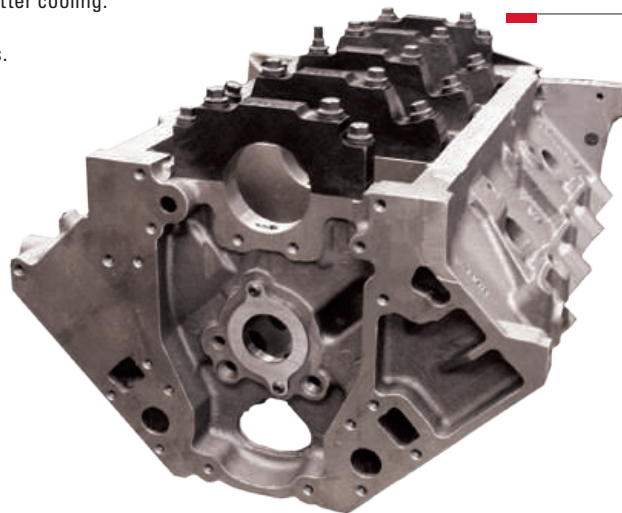
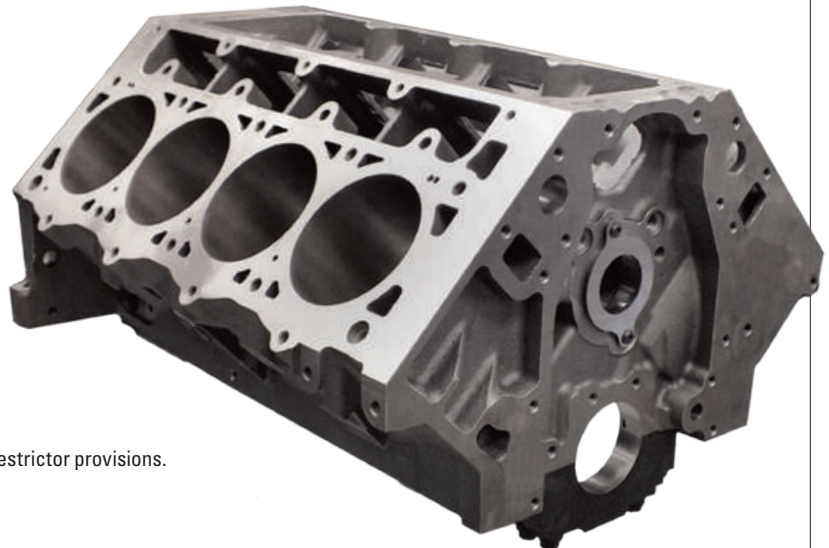

### LS NEXT [RACE BLOCK] SPECS

Material:	220 BHN Cast Iron
Deck Height:	9.240" (stock) up to 9.450"
Cylinder Bores:	4.000" up to 4.200" (max)
Main Bearings:	Stock LS
Main Caps:	Steel 4-bolt 1-5
Cam Location:	Stock
Lifter Bores:	Stock .842" dia.
Freeze Plugs:	Press fit
Rear Seal:	Stock LS
Weight:	227 lbs.

BILLET

HON

SBF

BBC

LS

SBC

ACCESS

MANIFOLDS

HEADS

BLOCKS

TOP END KITS

SHORT BLOCKS

# LS NEXT

## GEN III CAST ALUMINUM BLOCKS

### FULL SKIRT DESIGN

#### QUICK INFO >>>

Designed from a clean slate approach the LS Next Aluminum block has addressed the shortcomings of the LS platform and is the ideal candidate for hot rodders, drag racers, circle track competitors, off-roaders, and high performance marine enthusiasts.

Features Dart priority main oiling system with provisions for stock oil filter mounting. By utilizing conventional style main caps and oil pans with LS rotating assemblies and related components, Dart has addressed the windage and oil control problems which result from the factory LS engine's separated crankcase bays.

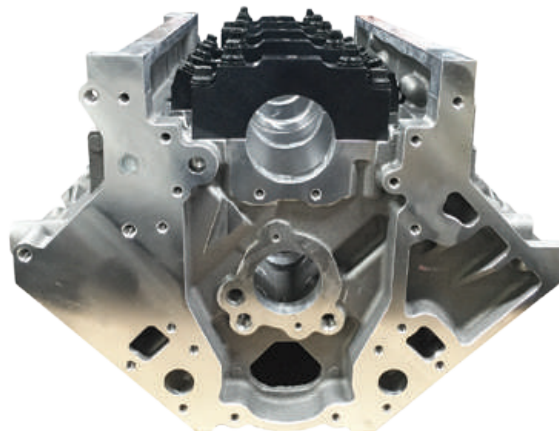
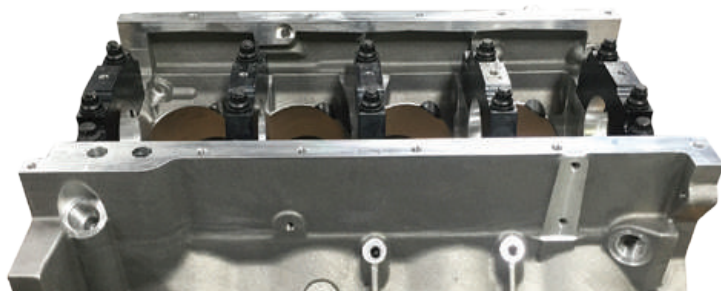
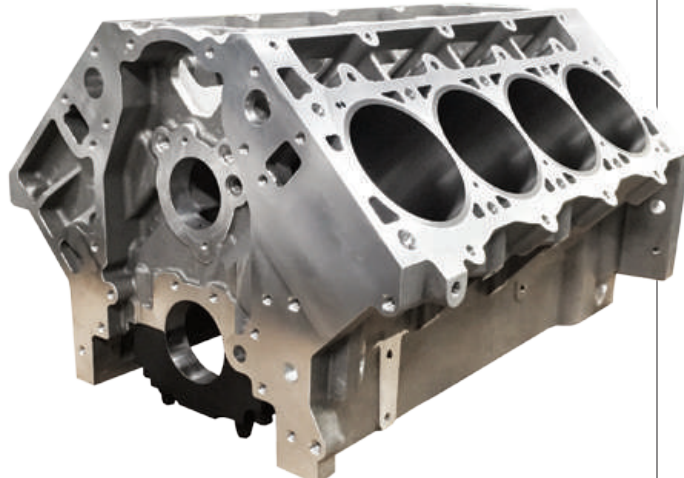

#### FEATURES

- Skirted and non-skirted design options available.
- Priority main oiling system.
- Available in deck heights from 9.240", 9.450", 9.750" up to 9.800".
- STD or raised .388" cam location.
- Cylinder barrels extended .375" at the bottom.
- Extra thick decks ensure reliable head gasket seal.
- Blind head bolt holes available in 7/16" or 1/2".
- Scalloped water jackets increase flow around cylinders for better cooling.
- Clearance for 4.100" stroke with steel rods.
- MUST BE clearanced for center counterweighted crankshafts.
- Splayed outer bolts on middle main bearing caps.
- LS style motor mounts.
- Provisions for OE stock roller lifters and cam.
- Uses stock timing covers and stock rear cover.
- All OE bolt holes for starter, water pump, etc.
- Driver or passenger side starter mounts (Not available with skirted version).
- Parts kit included.

#### LS NEXT - GEN III - ALUMINUM (FULLY SKIRTED)

PART NO.	DESCRIPTION	REAR SEAL	CAPS	MAINS	DECK	BORE
31947111	LS Next Aluminum (Skirted)	STD	Steel	STD	9.240"	4.000"
31947112	LS Next Aluminum Raised Cam (Skirted)	STD	Steel	STD	9.240"	4.000"
31947211	LS Next Aluminum (Skirted)	STD	Steel	STD	9.240"	4.125"
31947212	LS Next Aluminum Raised Cam (Skirted)	STD	Steel	STD	9.240"	4.125"
31947121	LS Next Aluminum (Skirted)	STD	Steel	STD	9.450"	4.000"
31947122	LS Next Aluminum Raised Cam (Skirted)	STD	Steel	STD	9.450"	4.000"
31947221	LS Next Aluminum (Skirted)	STD	Steel	STD	9.450"	4.125"
31947222	LS Next Aluminum Raised Cam (Skirted)	STD	Steel	STD	9.450"	4.125"
31947142	LS Next Aluminum Raised Cam (Skirted)	STD	Steel	STD	9.750"	4.000"
31947242	LS Next Aluminum Raised Cam (Skirted)	STD	Steel	STD	9.750"	4.125"

#### LS NEXT SPECS

Material:	RMR Cast Aluminum Alloy
Deck Height:	9.240", 9.450", 9.750" up to 9.800"
Cylinder Bores:	4.000" up to 4.165" (max)
Main Bearings:	Stock LS
Main Caps:	Steel 4-bolt 1-5
Cam Location:	Standard or raised .388"
Lifter Bores:	Stock .842" dia.
Freeze Plugs:	Screw-in
Rear Seal:	Stock LS
Weight:	115 lbs.



# LS NEXT

## GEN III CAST ALUMINUM BLOCKS

### QUICK INFO >>>

*Designed from a clean slate approach the LS Next Aluminum block has addressed the shortcomings of the LS platform and is the ideal candidate for hot rodders, drag racers, circle track competitors, off-roaders, and high performance marine enthusiasts.*

By utilizing conventional style main caps and oil pans with LS rotating assemblies and related components, Dart has addressed the windage and oil control problems which result from the factory LS engine's separated crankcase bays.

### FEATURES

- Skirted and non-skirted design options available.
- Priority main oiling system.
- Available in deck heights from 9.240", 9.450", 9.750" up to 9.800".
- STD or raised .388" cam location.
- Cylinder barrels extended .375" at the bottom.
- Extra thick decks ensure reliable head gasket seal.
- Blind head bolt holes available in 7/16" or 1/2".
- Scalloped water jackets increase flow around cylinders for better cooling.
- Clearance for 4.100" stroke with steel rods.
- MUST BE cleared for center counterweighted crankshafts.
- Splayed outer bolts on middle main bearing caps.
- LS style motor mounts.
- Provisions for OE stock roller lifters and cam.
- Uses stock timing covers and stock rear cover.
- All OE bolt holes for starter, water pump, etc.
- Driver or passenger side starter mounts (Not available with skirted version).
- Parts kit included.

### LS NEXT OIL PAN RAIL SPACERS

PART NO.	DESCRIPTION
62230001	LS Next Oil Pan Rail Spacers w/ power steering, AC & oil dipstick provision.

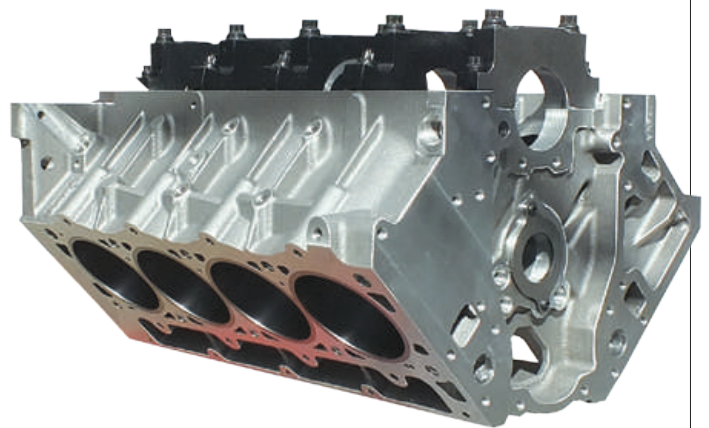

### LS NEXT - GEN III - ALUMINUM

PART NO.	DESCRIPTION	REAR SEAL	CAPS	MAINS	DECK	BORE
31937111	LS Next Aluminum	STD	Steel	STD	9.240"	4.000"
31937112	LS Next Aluminum Raised Cam	STD	Steel	STD	9.240"	4.000"
31937211	LS Next Aluminum	STD	Steel	STD	9.240"	4.125"
31937212	LS Next Aluminum Raised Cam	STD	Steel	STD	9.240"	4.125"
31937121	LS Next Aluminum	STD	Steel	STD	9.450"	4.000"
31937122	LS Next Aluminum Raised Cam	STD	Steel	STD	9.450"	4.000"
31937221	LS Next Aluminum	STD	Steel	STD	9.450"	4.125"
31937222	LS Next Aluminum Raised Cam	STD	Steel	STD	9.450"	4.125"
31937142	LS Next Aluminum Raised Cam	STD	Steel	STD	9.750"	4.000"
31937242	LS Next Aluminum Raised Cam	STD	Steel	STD	9.750"	4.125"

### LS NEXT SPECS

Material:	RMR Cast Aluminum Alloy
Deck Height:	9.240", 9.450", 9.750" up to 9.800"
Cylinder Bores:	4.000" up to 4.165" (max)
Main Bearings:	Stock LS
Main Caps:	Steel
Cam Location:	4-bolt 1-5 Standard or raised .388"
Lifter Bores:	Stock .842" dia.
Freeze Plugs:	Screw-in
Rear Seal:	Stock LS
Weight:	115 lbs.

BILLET

HON

SBF

BBC

LS

SBC

ACCESS

MANIFOLDS

HEADS

BLOCKS

TOP END KITS

SHORT BLOCKS

# LSNEXT<sup>2</sup>

## GEN III - SPECIAL UPGRADE

**STRENGTH TO THE NEXT POWER!**

### SPECIAL UPGRADE INFO >>>

The ultimate upgrade for adding strength in the Aluminum or Iron LS Next platform is the LS NEXT<sup>2</sup> upgrade. This offers larger Billet Steel main caps using Ford (2.750") or LS (2.560") mains, that feature 1/2" main studs giving superior clamping force for even higher power levels. Blocks come machined to accept fully counterweighted crankshafts.

### LS NEXT<sup>2</sup> - IRON AND ALUMINUM BLOCKS

PART NO.	DESCRIPTION
UP - LSN2AL2560	LSN2 Aluminum upgrade to (2.560" LS) with 1/2" mains
UP - LSN2AL2750	LSN2 Aluminum upgrade to (2.750" Ford) with 1/2" mains
UP - LSN2IR2560	LSN2 Iron upgrade to (2.560" LS ) with 1/2" mains
UP - LSN2IR2750	LSN2 Iron upgrade to (2.750" Ford) with 1/2" mains

*\*Not available on SHP LS Next*



Stock - 10mm



Standard LS NEXT - 7/16"



**LSNEXT<sup>2</sup> - 1/2"**

Using Ford (2.750") or LS (2.560") mains, with .500" main studs.

**FEATURES**  
**1/2" MAIN STUDS**

### FEATURES

- 9.240" - 9.450" deck height with standard cam.
- 9.240", 9.450" - 9.800" deck height with .388" raised cam.
- Available in Iron or Aluminum (skirted and non-skirted) blocks with LS (2.560") or Ford (2.750") main sizes for improved crankshaft stability.
- Larger 4 bolt Billet Steel main caps.
- Clearanced for center counterweighted crankshafts.

For **CAST IRON,**  
**CAST ALUMINUM,**  
or **BILLET.**

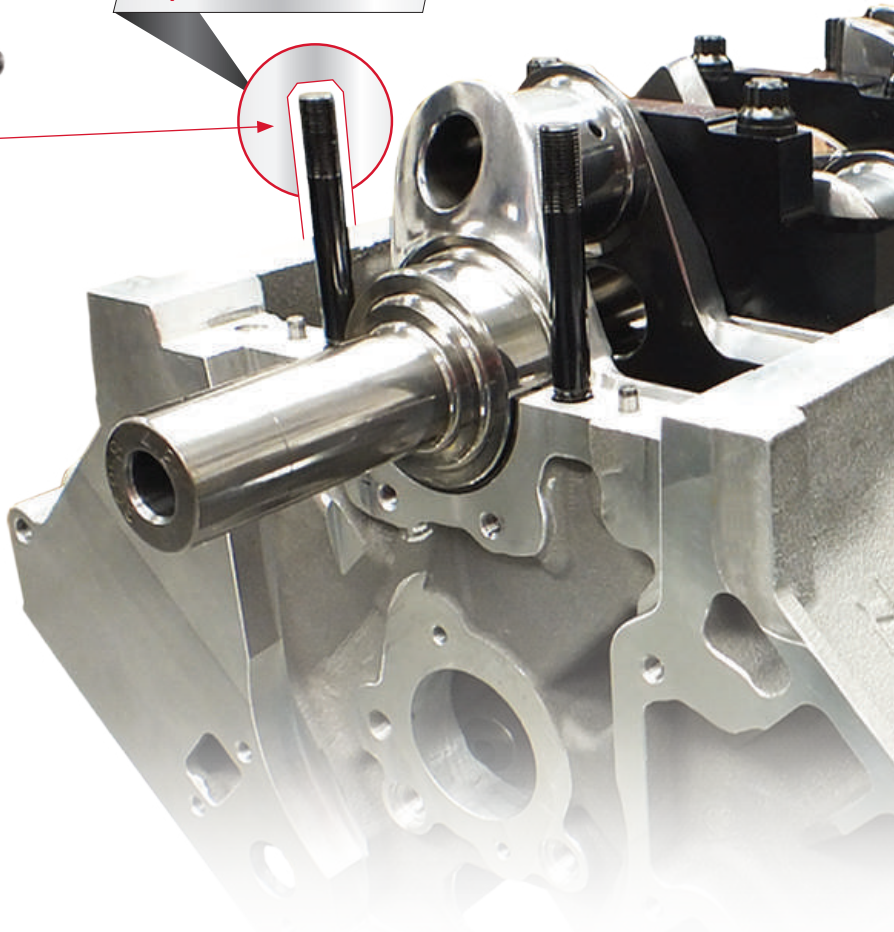

# PRO 1 LS 15° 205cc LS

## GEN III - CATHEDRAL PORT CAST ALUMINUM CYLINDER HEADS

### QUICK INFO >>>

PRO1 LS 15° 205cc intake runner covers applications from street cars and trucks to racing. As cast ports flow more than many ported designs at a much more affordable price.

Dart's 15° 205cc Aluminum cathedral port cylinder heads for GM LS series small block V8 engines offer higher performance and more versatility than factory designs.

The Dart LS cathedral port high performance cylinder has better airflow, more efficient combustion chambers, and more user friendly features than production LS castings.

The Dart LS style cylinder head retains stock valve angles, stock valve locations and stock accessory mounting holes to make installation easy. Virtually everything else has been improved.

**Heads are sold individually.**

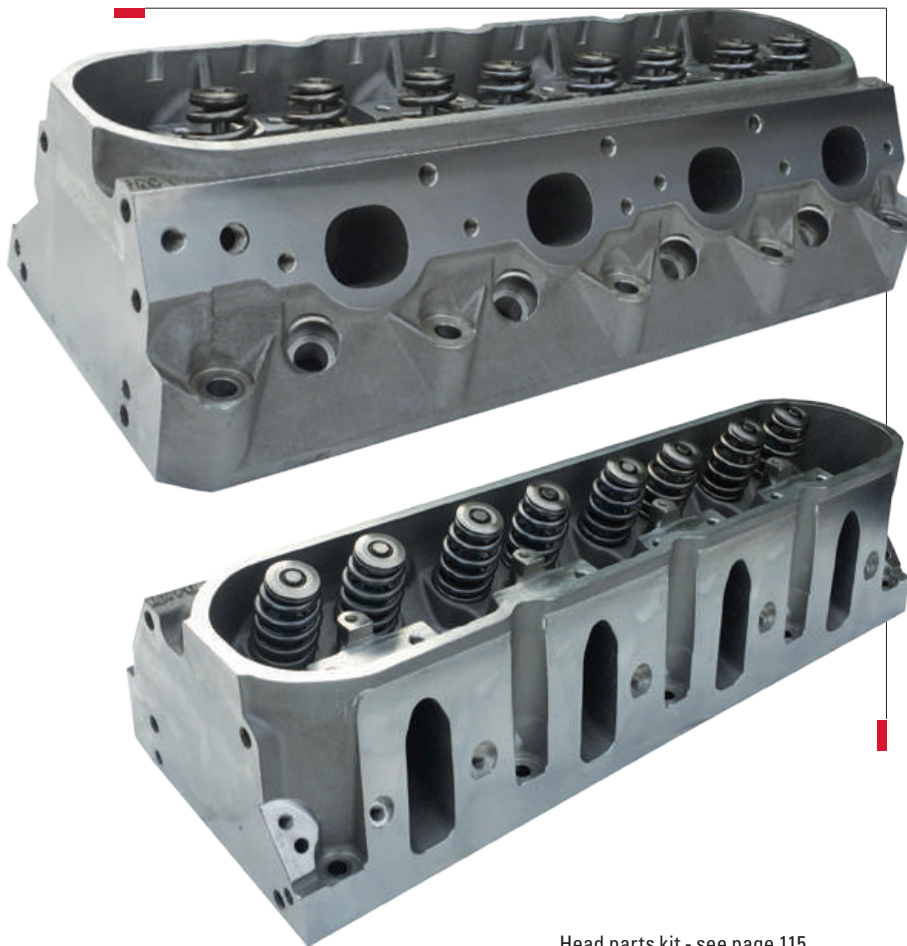

Head parts kit - see page 115.



### PRO1 LS 15° 205cc SPECS

Material:	RMR Cast Aluminum Alloy
Valve Angle:	15° (stock)
Intake Port Volume:	205cc
Intake Valve:	2.020"
Exhaust Valve:	1.600"
Chamber Volume:	62cc

### FLOW DATA @ 28" WATER

LIFT	INTAKE	EXHAUST
.200"	156	109
.300"	215	154
.400"	258	187
.500"	290	205
.600"	298	214

### PRO1 LS 15° 205cc - ALUMINUM - LS1 COMPATIBLE [CATHEDRAL PORT]

PART NO.	CONFIGURATION FOR USE	VALVES	MAX. LIFT
11010010	Bare Head	2.020"/1.600" VJ	
11011112	1.290" Beehive Springs for Hydraulic Roller	2.020"/1.600"	.625"

BILLET  
HON  
SBF  
BBC  
LS  
SBC  
ACCESS  
MANIFOLDS  
HEADS  
BLOCKS  
TOP END KITS  
SHORT BLOCKS

# PRO 1<sup>LS</sup> 15° 225cc LS

## GEN III - CATHEDRAL PORT CAST ALUMINUM CYLINDER HEADS

### QUICK INFO >>>

PRO1 LS 15° 225cc intake runner covers applications from street cars and trucks to racing. As cast ports flow more than many ported designs at a much more affordable price.

Dart's 15° 225cc Aluminum cathedral port cylinder head for GM LS series small block V8 engines offers higher performance and more versatility than factory designs.

The Dart LS high performance cylinder head has better airflow, more efficient combustion chambers, and more user friendly features than production LS castings.

The Dart LS style cylinder head retains stock valve angles, stock valve locations and stock accessory mounting holes to make installation easy. Virtually everything else has been improved.

**Heads are sold individually.**



Head parts kit - see page 115.

### PRO1 LS 15° 225cc SPECS

Material:	RMR Cast Aluminum Alloy
Valve Angle:	15° (stock)
Intake Port Volume:	225cc
Intake Valve:	2.050"
Exhaust Valve:	1.600"
Chamber Volume:	62cc

### FLOW DATA @ 28" WATER

LIFT	INTAKE	EXHAUST
.200"	144	109
.300"	202	154
.400"	254	187
.500"	290	205
.600"	313	214

### PRO1 LS 15° 225cc - ALUMINUM - LS1 COMPATIBLE [CATHEDRAL PORT]

PART NO.	CONFIGURATION FOR USE	VALVES	MAX. LIFT
11020020	Bare Head	2.050"/1.600" VJ	
11021122	1.290" Beehive Springs for Hydraulic Roller	2.050"/1.600"	.625"
11021123	1.295" Dual Spring for Hydraulic Roller	2.050"/1.600" VJ	.650"



# PRO1 LS 15° 250cc LS - CNC GEN III - CATHEDRAL PORT CAST ALUMINUM CYLINDER HEADS

## QUICK INFO >>>

Recommended for engines with 4.000" bore or larger. Maximum competition, competition modified drag racing, circle track. Over 7,000 RPM.

Dart's PRO1 LS 15° 250cc CNC ported Aluminum cathedral port cylinder heads for GM LS series small block V8 engines take performance to the next level.

This LS CNC cathedral port head is machined on a dedicated casting with extra thick sections to maintain the proper wall thickness after porting. Due to the large diameter intake valves, the Dart LS CNC head is recommended for use on engines with 4.000 inch and larger cylinder bores. Precise computer controlled CNC machining, multi-angle intake seats, and radiused exhaust seats enhance airflow. Extra material above the ports accommodates valve train upgrades.

**Heads are sold individually.**



## PRO1 LS 15° 250cc CNC - ALUMINUM - LS1 COMPATIBLE [CATHEDRAL PORT]

PART NO.	CONFIGURATION FOR USE	VALVES	MAX. LIFT
11071040	Bare Head	2.080"/1.600" VJ	
11071142	1.290" Beehive Springs for Hydraulic Roller	2.080"/1.600"	.625"
11071143	1.295" Dual Springs for Hydraulic Roller	2.080"/1.600"	.650"

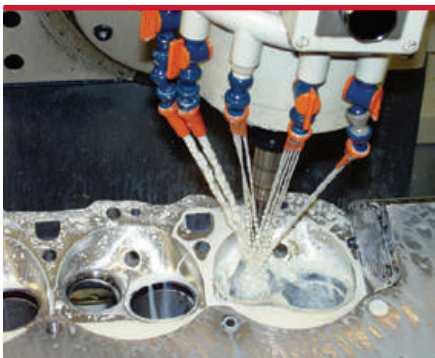

The consistency and accuracy of CNC (Computer Numerical Control) machining makes every CNC ported Dart head virtually identical. Our automated 5-axis machining centers port heads with incredible accuracy, and you get the performance benefits at a very affordable price!

Head parts kit - see page 115.

## PRO1 LS 15° 250cc CNC SPECS

Material:	RMR Cast Aluminum Alloy
Valve Angle:	15° (stock)
Intake Port Volume:	250cc CNC
Intake Valve:	2.080"
Exhaust Valve:	1.600"
Chamber Volume:	68cc

## FLOW DATA @ 28" WATER

LIFT	INTAKE	EXHAUST
.200"	144	114
.300"	214	157
.400"	264	192
.500"	305	219
.600"	344	240

BILLET

HON

SBF

BBC

LS

SBC

ACCESS

MANIFOLDS

HEADS

BLOCKS

TOP END KITS

SHORT BLOCKS

# PRO1 LS 15° 280cc LS

## GEN III - RECTANGLE PORT CAST ALUMINUM CYLINDER HEADS

### QUICK INFO >>>

Recommended for engines with 4.000" bore or larger. Maximum competition, comp/modified drag racing, circle track, and heavy duty applications.

Dart's LS based PRO1 LS 15° 280cc Aluminum rectangle port cylinder head (LS3 compatible) for GM LS series small block V8 engines take performance to the next level. Offers higher performance and more versatility than factory designs.

The 15° based high performance cylinder head has better airflow, more efficient combustion chambers and more user friendly features than production LS castings. The Dart PRO1 280cc cylinder head retains stock valve angles, stock valve locations and stock accessory mounting holes to make installation easy. Virtually everything else has been improved.

Heads are sold individually.

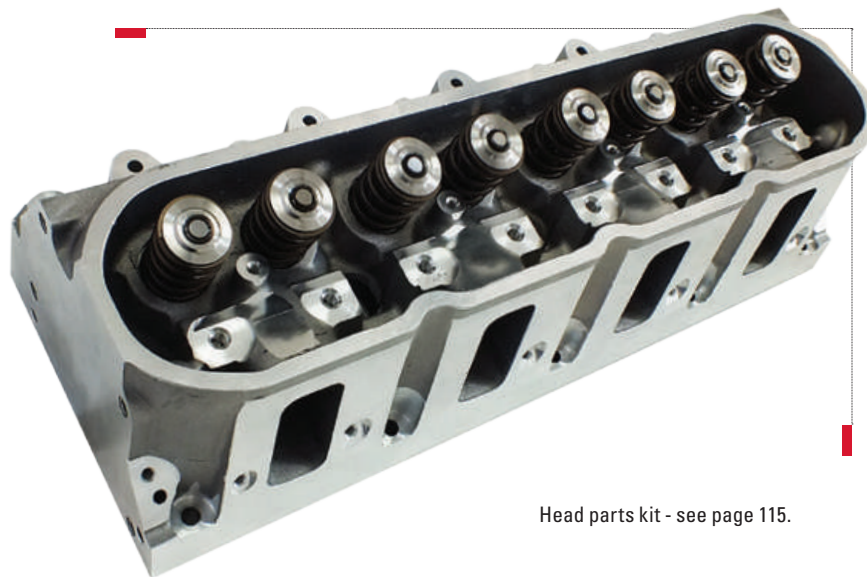

Head parts kit - see page 115.

## UPGRADE

SMC (SUPER MOD COMPLETE)



### PRO1 LS 15° 280cc SPECS

Material:	RMR Cast Aluminum Alloy
Valve angle:	15°
Intake port volume:	280cc
Intake valve:	2.165"
Exhaust valve:	1.600"
Chamber Volume:	68cc

### [SMC] PRO1 LS 15° 282cc SPECS

Material:	RMR Cast Aluminum Alloy
Valve angle:	15°
Intake port volume:	282cc
Intake valve:	2.165"
Exhaust valve:	1.600"
Chamber Volume:	68cc

### FLOW DATA @ 28" WATER

LIFT	INTAKE	EXHAUST
.200"	163	126
.300"	233	171
.400"	283	204
.500"	321	235
.600"	343	244
.700"	371	249

### [SMC] FLOW DATA @ 28" WATER

LIFT	INTAKE	EXHAUST
.200"	155	130
.300"	222	171
.400"	269	199
.500"	318	228
.600"	356	244
.700"	376	252

### PRO1 LS 15° 280cc - ALUMINUM - LS3 COMPATIBLE [RECTANGLE PORT]

PART NO.	CONFIGURATION FOR USE	VALVES	MAX. LIFT
11030050	Bare Head		
11030152	1.290" Beehive springs for Hydraulic roller	2.165" / 1.600"	.625"
11030153	1.295" Dual springs for Hydraulic roller	2.165" / 1.600"	.650"

# PRO1 LS

12°  
285cc  
LS - CNC

## GEN III - RECTANGLE PORT CAST ALUMINUM CYLINDER HEADS

### QUICK INFO >>>

Recommended for engines with 4.125" bore or larger. Maximum competition, comp/modified drag racing, circle track, and heavy duty applications.

Dart's new PRO1 LS 12° 285cc CNC Aluminum rectangle port cylinder head for GM LS7 Compatible small block V8 engines take performance to the next level. This full CNC ported cylinder head offers higher performance and more versatility than factory designs.

The 12° based high performance cylinder head has better airflow, more efficient combustion chambers and more user friendly features than production LS castings. The Dart PRO1 285cc cylinder head retains stock valve angles, stock valve locations and stock valve train mounting with dowel holes to make installation easy and durable.

**Dart Rocker bar included (61400011).**

**Heads are sold individually.**



Head parts kit - see page 115.

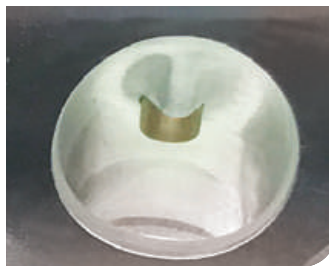

### RECOMMENDED MANIFOLD

45311021

See page 63



### PRO1 LS 12° 285cc CNC [LS] SPECS

Material:	RMR Cast Aluminum Alloy
Valve angle:	12°
Intake port volume:	285cc CNC
Intake valve:	2.200"
Exhaust valve:	1.625"
Chamber Volume:	66cc

### FLOW DATA @ 28" WATER

Flowed on Super Flow 1020

LIFT	INTAKE	EXHAUST
.200"	162	118
.300"	233	164
.400"	293	208
.500"	334	230
.600"	361	244
.700"	380	252
.800"	381	263

### PRO1 LS 12° 285cc CNC - ALUMINUM - LS7 COMPATIBLE [RECTANGLE PORT]

PART NO.	CONFIGURATION FOR USE	VALVES	MAX. LIFT
11060000	C-Core Casting	N/A	N/A
11061080	Bare head (Dart Rocker Bar Machining)	2.200" / 1.625"	N/A
11061080J	Bare head (Jesel Rocker Bar Machining)	2.200" / 1.625"	N/A
11061182	1.290" Beehive springs for Hydraulic roller	2.200" / 1.625"	.625"
11061183	1.295" Dual springs for Hydraulic roller	2.200" / 1.625"	.650"
11061184	1.310" Dual springs for Solid roller	2.200" / 1.625"	.650"

BILLET

HON

SBF

BBC

LS

SBC

ACCESS

MANIFOLDS

HEADS

BLOCKS

TOP END KITS

SHORT BLOCKS

**10°**  
**368cc**  
**LS - CNC**

**GEN III - OVAL PORT**  
**CAST ALUMINUM CYLINDER HEADS**

**QUICK INFO >>>**

Recommended for maximum competition LS engines with 4.155" bore or larger. Drag race, maximum competition, naturally aspirated, heavy nitrous or forced induction applications.

Dart's New Race Series 10° LS cylinder head is the ultimate choice for maximum competition. Designed with raised Pro Stock oval ports, canted valves and highly efficient wedge style combustion chambers, the Race Series 10° LS is a radical departure from traditional LS heads in one other area. The intake and exhaust valve locations for each cylinder have been reversed. This feature has been the standard for maximum power wedge engines for decades.

The huge flow resulting from the 10° valve angle, splayed valve layout, reversed symmetrical intake ports, and highly efficient combustion chambers deliver maximum power!

It is recommended that you contact a Dart technical representative before placing an order for this item. Detailed information about your planned engine build will help to ensure that you choose the right configuration for your motor and that any special parts are taken into consideration.

*\*Optional Front Water Inlet Machining.*

*Heads are sold individually.*

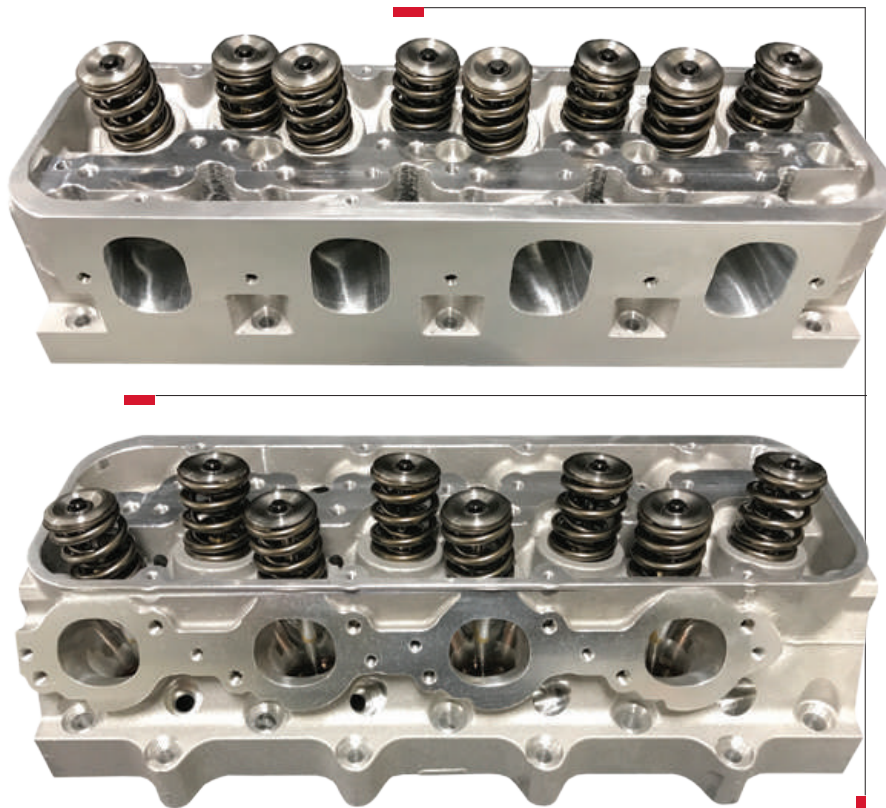

Requires Jesel Shaft Mount Rockers.

Uses Custom Gen5, LT1 style camshaft.



**RACE SERIES LS 10° 368cc CNC SPECS**

Material: Cast Aluminum Alloy  
Valve Angle: 10° (stock)  
Intake Port Volume: 368cc CNC  
Intake Valve: 2.300"  
Exhaust Valve: 1.600"  
Chamber Volume: 57cc

**FLOW DATA @ 28" WATER**

LIFT	INTAKE	EXHAUST
.200"	167	117
.300"	252	163
.400"	320	204
.500"	378	241
.600"	419	267
.700"	437	288
.800"	446	304
.900"	452	311
1.000"	456	316

**RACE SERIES LS 10° 368cc CNC - ALUMINUM [OVAL PORT]**

<b>PART NO.</b> 11081050	<b>CONFIGURATION FOR USE</b> Bare head	<b>VALVES</b> 2.300"/1.600" VJ	<b>MAX. LIFT</b>
-----------------------------	---	-----------------------------------	------------------



# LS

## INTAKE MANIFOLDS

# GEN III CAST ALUMINUM LS MANIFOLDS

An engine's cylinder heads and intake manifold must work together as an integrated system to produce maximum performance. The intake charge should make a seamless transition from the manifold runners to the cylinder head ports. We've optimized the port shape, the plenum volumes, and the runner angle for each application.

### PRO1 LS 12° SINGLE PLANE INTAKE MANIFOLD (LS7 COMPATIBLE)

PART NO	DESCRIPTION	PORT STYLE	DECK	CARB	INJ. MACHINING	CNC
45310000	2-PC Split Single Plane	Raw	N/A	N/A	N/A	N/A
45311020	2-PC Split Single Plane	Rectangle	9.240"	4150	No	No
45311021	2-PC Split Single Plane	Rectangle	9.240"	4150	Yes	No
45311024	2-PC Split Single Plane	Rectangle	9.240"	4150	No	Yes
45311025	2-PC Split Single Plane	Rectangle	9.240"	4150	Yes	Yes

### RACE SERIES LS 10° BOX RAM INTAKE MANIFOLD

PART NO	DESCRIPTION	PORT STYLE	DECK	CARB	INJ. MACHINING
45241100	10° LS Box Ram	Oval	9.240"	4500	No
45242100	10° LS Box Ram	Oval	9.450"	4500	No
45243100	10° LS Box Ram	Oval	9.750"	4500	No

### RACE SERIES LS 10° BOX RAM TOP PLATE AND ACCESSORIES

PART NO	DESCRIPTION	CARB
62450010	Pent Roof Box Ram Billet Top Plate	4500
62450010A	Pent Roof Box Ram Gasket and Spacer	N/A

**45311021**  
**PRO1 LS 12° SINGLE PLANE (LS7 COMPATIBLE)**

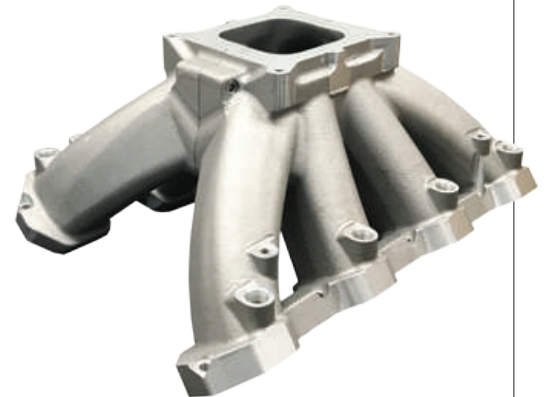

**45241100**  
**RACE SERIES LS 10° BOX RAM**



**62450010**  
**RACE SERIES LS 10° BOX RAM BILLET TOP PLATE**



BILLET

HON

SBF

BBC

LS

SBC

ACCESS

MANIFOLDS

HEADS

BLOCKS

TOP END KITS

SHORT BLOCKS

# GEN III - LS NEXT ACCESSORIES

## LS FABRICATED VALVE COVER

PART NO.	DESCRIPTION
68000090	Fabricated Aluminum Valve Cover for the parameter bolt pattern Race Series LS 10° and Billet LS cylinder heads (includes gaskets and hardware).



## LS NEXT OIL PAN RAIL SPACERS

PART NO.	DESCRIPTION
62230001	LS Next Oil Pan Rail Spacers with power steering, AC & oil dipstick provision.



## LS NEXT/SHP LS NEXT WINDAGE TRAYS

PART NO.	DESCRIPTION
32000118	LS Next SHP Windage Tray kit (LS1, LS2, LS3, LS6)
32000119	LS Next SHP Windage Tray kit (LS7)

*\*Not compatible with LS NEXT<sup>2</sup> Upgrade*

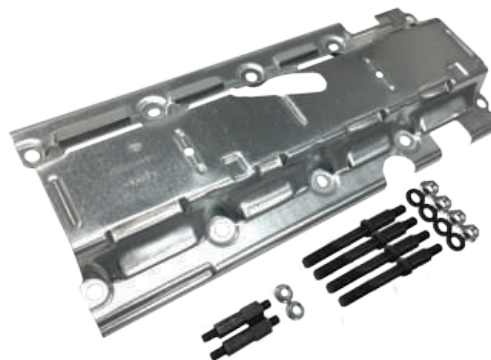

## LS NEXT HEAD STUD KITS

PART NO.	ENGINE	DESCRIPTION
66120017	LS	7/16" 23 bolt 10° Race Series Iron LS Next Block
66120018	LS	7/16" 15 bolt Iron LS Next Block
66120018B	LS	7/16" 23 bolt (LS3/LS7) Iron LS Next Block
66130018	LS	1/2" 15 bolt Iron LS Next Block
66130018B	LS	1/2" 23 bolt (LS3/LS7) Iron LS Next Block
66120027	LS	7/16" 23 bolt 10° Race Series Aluminum LS Next Block
66120028	LS	7/16" 15 bolt Aluminum LS Next Block
66120028B	LS	7/16" 23 bolt (LS3/LS7) Aluminum LS Next Block
66130128	LS	1/2" 15 bolt Aluminum LS Next Block
66130128B	LS	1/2" 23 bolt (LS3/LS7) Aluminum LS Next Block

## HEAD PART KITS

Dart parts kits include everything you need to assemble a cylinder head: Stainless Steel valves, springs, locks, retainers, seals, studs, and guide plates. These kits contain the same high quality components we use in our cylinder head assemblies. Each kit does one cylinder head.



## GEN III LS HEAD PARTS KITS

PART NO.	INT.	EXH.	SPRING	DESCRIPTION
28112100	2.020"	1.600"	1.290" single	PRO1 205cc LS
28212100	2.050"	1.600"	1.290" single	PRO1 225cc LS
28422200	2.080"	1.600"	1.295" double	PRO1 250cc LS
28811200	2.165"	1.600"	1.290" single	PRO1 280cc LS
28812200	2.165"	1.600"	1.295" double	PRO1 280cc LS

## DART LS7 COMPATIBLE ROCKER BAR

PART NO.	DESCRIPTION
61400011	Dart LS7 Compatible Rocker Bar (for use with P/N: 11061080)



## LS NEXT CAM THRUST PLATE WITH HARDWARE

PART NO.	DESCRIPTION
32226000	LS Next Cam Thrust Plate with Hardware



BILLET

HON

SBF

BBC

LS

SBC

ACCESS

MANIFOLDS

BLOCKS

TOP END KITS

SHORT BLOCKS

# BIG BLOCK CHEVY TOP END KITS - CAST IRON OR CAST ALUMINUM

## QUICK INFO >>>

Performance matched top end kits from Dart are the perfect way to finish off your Dart short block or upgrade your existing engine.

Dart top end kits for big block Chevy engines offer a full compliment of performance matched parts that make building your engine simple and easy. These kits were designed to deliver excellent performance at a great price!



## DART TOP END KITS INCLUDE:

- Fully assembled cylinder heads.
- Chromed steel valve covers with gaskets and hardware.
- Intake manifold, selected to compliment the cylinder heads.
- Intake gaskets, head gaskets, and exhaust gaskets.
- Spark plugs.
- Head bolts.
- Rocker studs and guideplates.



See pages 72-74 for more information on Iron Eagle cylinder heads.

### BBC TOP END KITS WITH IRON EAGLE CYLINDER HEADS

PART NO.	HEADS	PORTS	PORT SHAPE	CHAMBER	VALVES	SPRINGS	TYPE OF SPRING	MANIFOLD
01120005	Iron	308cc	Rect.	121cc	2.250"/1.880"	1.550"D	Solid Roller	Single Plane
01120008	Iron	345cc	Rect.	121cc	2.300"/1.880"	1.625"D	Solid Roller	Single Plane



See pages 75-84 for more information on PRO1 cylinder heads.

### BBC TOP END KITS WITH PRO1 ALUMINUM CYLINDER HEADS

PART NO.	HEADS	PORTS	PORT SHAPE	CHAMBER	VALVES	SPRINGS	TYPE OF SPRING	MANIFOLD
01220023	Aluminum	275cc	Oval	121cc	2.250"/1.880"	1.550"D	Solid Roller	Single Plane
01220006	Aluminum	310cc	Rect.	121cc	2.250"/1.880"	1.550"D	Solid Roller	Single Plane
01220007	Aluminum	325cc	Rect.	121cc	2.250"/1.880"	1.550"D	Solid Roller	Single Plane
01220008	Aluminum	345cc	Rect.	121cc	2.300"/1.880"	1.625"D	Solid Roller	Single Plane
01220010	Aluminum	335cc CNC	Rect.	121cc	2.300"/1.880"	1.625"D	Solid Roller	Single Plane



**MRK IV  
GEN V  
GEN VI**

# BIG BLOCK CHEVY CAST IRON ENGINE BLOCKS

## SIAMESE AND NON-SIAMESE

### QUICK INFO >>>

Engineered for applications where water between the bores is a requirement. Siamese bore versions are also available for larger bore applications.

MRK IV blocks use the 2-piece rear seal design. Gen V and Gen VI blocks use a 1-piece rear seal as well as a different timing cover pattern.

These blocks are based on Dart's Big M design, and include features like priority main oiling and 4-bolt main caps.

### FEATURES

- Standard 9.800" and tall 10.200" deck heights available.
- Standard 4.250", 4.310", 4.500" and 4.600".
- Uses +.300" tall Gen VI style lifters. Modification for Gen IV style available.
- 4-bolt main bearing caps in Ductile Iron have splayed outer bolts for extra strength.
- Lifter valley bosses for OE style roller lifters and retainer (GEN VI only).
- Mechanical fuel pump boss, clutch linkage mounts, and side and front motor mounts simplify installation in any chassis.
- Parts kit sold separately (PN 32000002 - see page 115).

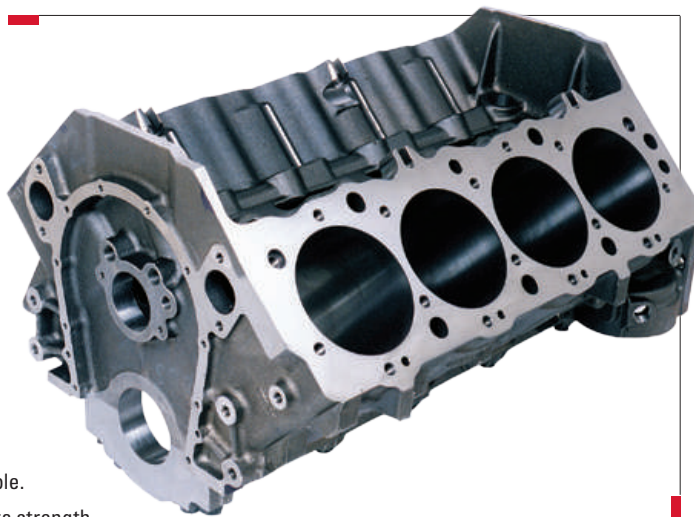

### BIG M MRK IV WATER [NON-SIAMESE] - IRON

PART NO.	CAPS	MAINS	CAM	DECK	BORE	REAR SEAL
31243244	Ductile	Std.	Std.	9.800"	4.310"	2-Piece
31243254	Ductile	Std.	Std.	10.200"	4.310"	2-Piece
31243344	Ductile	Std.	Std.	9.800"	4.250"	2-Piece
31243354	Ductile	Std.	Std.	10.200"	4.250"	2-Piece

### BIG M MARK IV WATER [NON-SIAMESE] 396 STYLE BLOCK - IRON [Legal for Super Stock]

31262044	Steel	Std.	Std.	9.800"	4.094"	2-Piece
----------	-------	------	------	--------	--------	---------

### BIG M GEN V WATER [NON-SIAMESE] - IRON

31243344V	Ductile	Std.	Std.	9.800"	4.250"	1-Piece
31243354V	Ductile	Std.	Std.	10.200"	4.250"	1-Piece
31243244V	Ductile	Std.	Std.	9.800"	4.310"	1-Piece
31243254V	Ductile	Std.	Std.	10.200"	4.310"	1-Piece

### BIG M GEN VI WATER [NON-SIAMESE] - IRON

31243344VI	Ductile	Std.	Std.	9.800"	4.250"	1-Piece
31243354VI	Ductile	Std.	Std.	10.200"	4.250"	1-Piece
31243244VI	Ductile	Std.	Std.	9.800"	4.310"	1-Piece
31243254VI	Ductile	Std.	Std.	10.200"	4.310"	1-Piece

### BIG M GEN V [SIAMESE] - IRON

31273344V	Ductile	Std.	Std.	9.800"	4.250"	1-Piece
31273354V	Ductile	Std.	Std.	10.200"	4.250"	1-Piece

### BIG M GEN VI [SIAMESE] - IRON

31273344VI	Ductile	Std.	Std.	9.800"	4.250"	1-Piece
31273354VI	Ductile	Std.	Std.	10.200"	4.250"	1-Piece
31273444VI	Ductile	Std.	Std.	9.800"	4.500"	1-Piece
31273454VI	Ductile	Std.	Std.	10.200"	4.500"	1-Piece



MRK IV, Gen V and Gen VI blocks with water between the bores are identified by a B suffix on the casting number.

### MK IV, GEN V & GEN VI SPECS

Material:	220 BHN Cast Iron
Deck Height:	9.800" 10.200"
Cylinder Bores	4.250" to
Non-Siamesed:	4.350" (max)
Siamesed:	4.600" (max)
Main Caps:	Ductile
Cam Location:	Standard
Lifter Bores:	Standard
Freeze Plugs:	Press fit
Rear Seal:	1 or 2-Piece
Weight:	250-280 lbs.

**BIG M**

**GEN VII**

# BIG BLOCK CHEVY 8.1/8.8L CAST IRON ENGINE BLOCKS

### QUICK INFO >>>

The Gen 7 8.1/8.8 liter big block was used in numerous marine and truck applications. Up until now, there have been very limited options for upgrading its performance potential.

Dart's new Gen VII block is available with full water jackets including between the cylinder bores, or with siamesed bores to enable larger displacements. The water block is available with a 4.350" bore diameter, and the siamesed bore blocks can be bored to 4.600" diameter.

### FEATURES

- Standard 10.236" deck height.
- 4.250" and 4.350" bore water blocks.
- 4.250" - 4.600" bore sizes for siamese blocks.
- Metric or SAE threads available.
- Provision for factory crank sensor.
- Uses Gen VI timing cover and oil pan.
- Blind head bolt holes.
- Lifter valley bosses for OE style roller lifters and retainer.
- Clutch linkage mounts, side and front motor mounts simplify installation in any chassis.

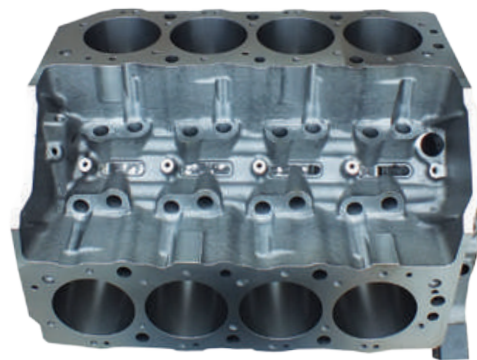
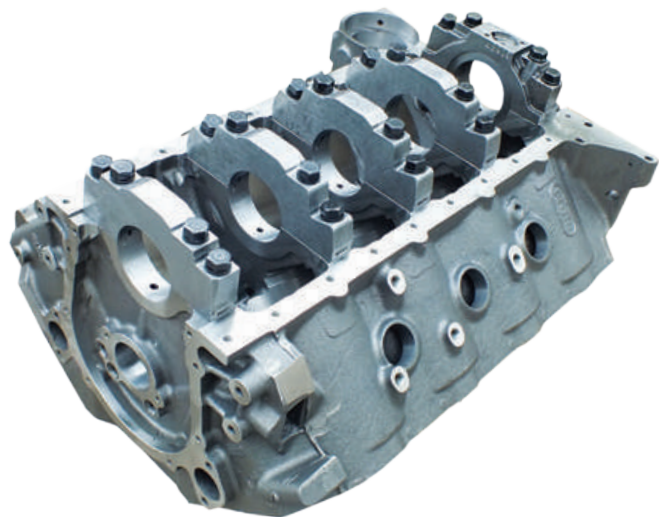
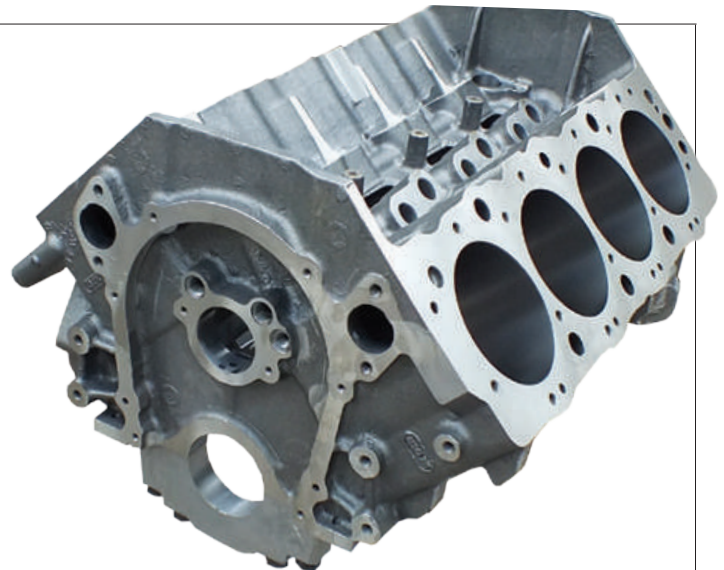
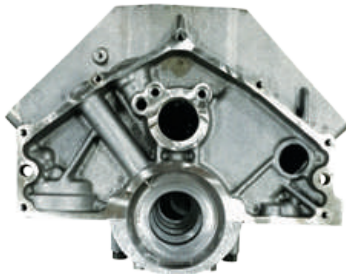

### GEN VII 8.1/8.8 LITER WATER (NON-SIAMESE) - IRON

PART NO.	MATL	CAPS	DECK HT.	BORE	THREAD
31253354	Iron	Ductile	10.236"	4.250"	Metric
31253354RMR	Iron	Ductile	10.236"	4.250"	SAE
31253254	Iron	Ductile	10.236"	4.350"	Metric
31253254RMR	Iron	Ductile	10.236"	4.350"	SAE

### GEN VII 8.1/8.8 LITER (SIAMESE) - IRON

PART NO.	MATL	CAPS	DECK HT.	BORE	THREAD
31253454	Iron	Ductile	10.236"	4.500"	Metric
31253454RMR	Iron	Ductile	10.236"	4.500"	SAE
31253654	Iron	Ductile	10.236"	4.600"	Metric
31253654RMR	Iron	Ductile	10.236"	4.600"	SAE
31253754	Iron	Ductile	10.236"	4.625"	Metric
31253754RMR	Iron	Ductile	10.236"	4.625"	SAE

BILLET

HON

SBF

BBC

LS

SBC

ACCESS

MANIFOLDS

HEADS

BLOCKS

TOP END KITS

SHORT BLOCKS

# BIG M SPORTSMAN

# BIG BLOCK CHEVY CAST IRON ENGINE BLOCKS

## QUICK INFO >>>

Dart engineered the Big M to be the strongest, most reliable, and easiest to build big block on the market.

With deck heights of 9.800" and 10.200" and bore sizes up to 4.600", the Big M gives you the versatility to build a wide variety of engine combinations.

The Big M is fitted with Billet Steel 4-bolt main caps for ultimate bottom end strength. The Sportsman block is fitted with Ductile Iron 4-bolt main caps.

## FEATURES

- Standard 9.800" and tall 10.200" deck heights.
- Standard 4.250", 4.500", 4.560" or 4.600" bore sizes with siamesed extra thick cylinder walls to resist cracking and improve ring seal (minimum .300" thick with 4.625" bore).
- Uses +.300" tall Gen VI style lifters. Modification for Gen IV style available.
- 4-bolt main bearing caps in steel or Ductile Iron have splayed outer bolts for extra strength.
- True priority main oil system lubricates the main bearings before the lifters. Our stepped main oil gallery (9/16" to 1/2" to 7/16") increases the flow of oil to the crank at high RPM, and our front oil crossover eliminates internal oil leaks around the distributor shaft.
- Lifter valley head stud bosses prevent blown head gaskets.
- Dual oil pan bolt patterns fit standard and notched oil pans.
- Big M Sportsman: Parts kit sold separately (PN 32000002 - see page 115).
- Big M: Parts kit included.

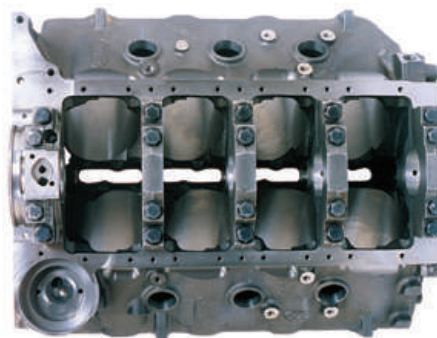
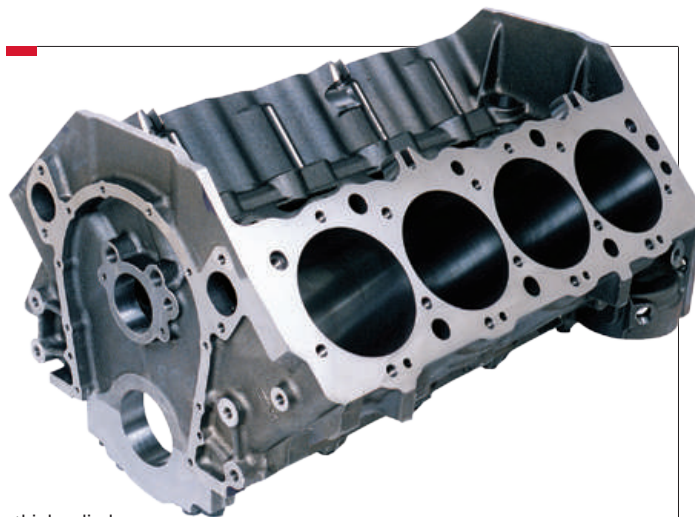

## BIG M SPORTSMAN - IRON

PART NO.	CAPS	MAINS	CAM	DECK	BORE
31273344	Ductile	Std.	Std.	9.800"	4.250"
31273354	Ductile	Std.	Std.	10.200"	4.250"
31273444	Ductile	Std.	Std.	9.800"	4.500"
31273454	Ductile	Std.	Std.	10.200"	4.500"
31273544	Ductile	Std.	Std.	9.800"	4.560"
31273554	Ductile	Std.	Std.	10.200"	4.560"
31273644	Ductile	Std.	Std.	9.800"	4.600"
31273654	Ductile	Std.	Std.	10.200"	4.600"

## BIG M - IRON

PART NO.	CAPS	MAINS	CAM	DECK	BORE
31263344	Steel	Std.	Std.	9.800"	4.250"
31263354	Steel	Std.	Std.	10.200"	4.250"
31263444	Steel	Std.	Std.	9.800"	4.500"
31263454	Steel	Std.	Std.	10.200"	4.500"
31263544	Steel	Std.	Std.	9.800"	4.560"
31263554	Steel	Std.	Std.	10.200"	4.560"
31263644	Steel	Std.	Std.	9.800"	4.600"
31263654	Steel	Std.	Std.	10.200"	4.600"

CGI Blocks - Turbocharged, Supercharged and Nitrous Applications! Dart Cast Iron blocks are available with Compacted Graphite Iron by special order. Double the strength without added weight.

Dart blocks can be special ordered with a wide array of special machining options to suit your specific requirements.

## BIG M & SPORTSMAN SPECS

Material:	220 BHN Cast Iron
Deck Height:	9.800" to 10.200"
Cylinder Bores:	4.250" to 4.600"
Main Caps:	Ductile or Steel
Cam Location:	Standard
Lifter Bores:	.842"
Freeze Plugs:	Press fit
Rear Seal:	2-Piece
Weight:	250-280 lbs.

# BIG M PRO

## BIG BLOCK CHEVY CAST IRON ENGINE BLOCKS

### QUICK INFO >>>

Dart re-engineered the big block, incorporating the most requested upgrades and special modifications into the Big M PRO blocks.

With deck heights from 9.600" to 11.100", a +.600" raised cam location, spread oil pan rails and bore sizes up to 4.600", the Big M PRO gives you the versatility to build a wide variety of engine combinations.

### FEATURES

- Deck Options from 9.600" to 11.100" or custom heights.
- Raised cam location +.600" clears stroker crankshafts.
- Oil pan rails are spread .750".
- Accepts crankshaft strokes up to 5.000 inch for large displacement applications with clearancing.
- Four valley head stud bosses prevent head gasket failures with high compression ratios and/or nitrous oxide. Slotted bosses allow the use of studs instead of difficult to install bolts (9.800 – 11.100 deck only).
- True priority main oiling directs oil to the main bearings before the lifters for reliability at high RPM. Stepped main oil gallery ensures uniform oil supply for all five main bearings.
- Oil crossovers located in the valley simplify restricting oil flow to the top end and deliver maximum oil volume to the main bearings ensuring reliable lubrication for the lifters and pushrods on both cylinder banks.
- Steel 4-bolt main bearing caps are manufactured in-house by Dart to ensure quality and compatibility with the block. Three center caps have splayed outer bolts that anchor the caps to the strongest part of the casting, front and rear caps have vertical bolts for oil pan clearance.
- Parts kit included (PN 32000005 - see page 115).

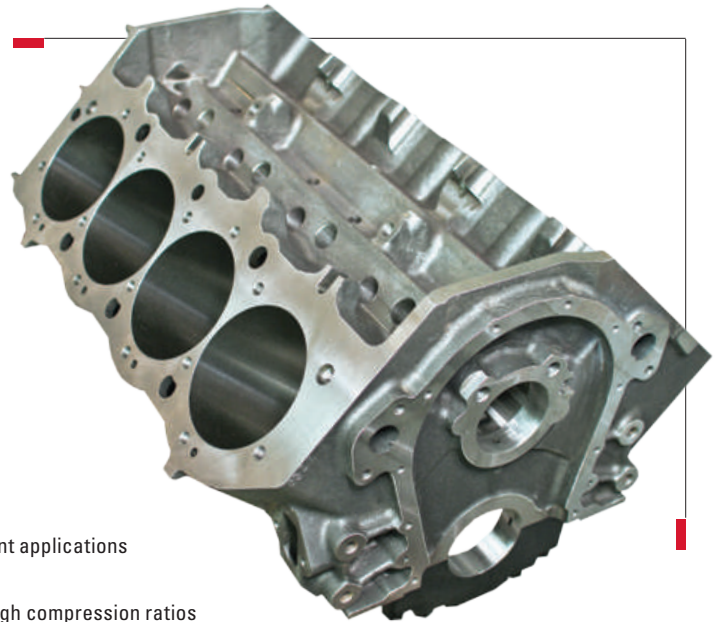

### BIG M PRO - IRON

PART NO.	CAPS	LIFTERS	CAM LOC.	CAM	DECK	BORE
31283435	Steel	.904"	+.600"	2.125"	9.600"	4.500"
31283635	Steel	.904"	+.600"	2.125"	9.600"	4.600"
31283445	Steel	.904"	+.600"	2.125"	9.800"	4.500"
31283645	Steel	.904"	+.600"	2.125"	9.800"	4.600"
31283485	Steel	.904"	+.600"	2.125"	10.000"	4.500"
31283685	Steel	.904"	+.600"	2.125"	10.000"	4.600"
31283455	Steel	.904"	+.600"	2.125"	10.200"	4.500"
31283655	Steel	.904"	+.600"	2.125"	10.200"	4.600"
31283495	Steel	.904"	+.600"	2.125"	10.400"	4.500"
31283695	Steel	.904"	+.600"	2.125"	10.400"	4.600"
31283465	Steel	.904"	+.600"	2.125"	10.600"	4.500"
31283665	Steel	.904"	+.600"	2.125"	10.600"	4.600"
31283475	Steel	.904"	+.600"	2.125"	11.100"	4.500"
31283675	Steel	.904"	+.600"	2.125"	11.100"	4.600"

### BIG M PRO SPECS

Material:	220 BHN Cast Iron
Deck Height:	9.600" to 11.100"
Cylinder Bores:	4.500" to 4.600"
Oil Pan Rails:	Spread .750"
Main Caps:	Steel
Cam Location:	Raised +.600"
Lifter Bores:	.904"
Freeze Plugs:	Press fit
Rear Seal:	2-Piece
Weight:	250-310 lbs.

BILLET

HON

SBF

BBC

LS

SBC

ACCESS

MANIFOLDS

HEADS

BLOCKS

TOP END KITS

SHORT BLOCKS



# BIG BLOCK CHEVY CAST ALUMINUM ENGINE BLOCKS

## QUICK INFO >>>

*Designed to be the strongest, most durable and easiest to build Aluminum big block available. The ultimate choice for competition engines.*

Based on the Chevrolet big block V8 design, these Aluminum blocks feature extra strengthening in critical areas, increased displacement capacity, true priority main oiling and precision CNC machining.

Conventional configuration that retains all production dimensions for compatibility with standard components. Advanced engineering makes Dart Aluminum big blocks the choice for serious competition.

## FEATURES

- Standard 9.800" or 10.200" tall deck heights available for stroker engines.
- 4.250", 4.500" or 4.600" bore sizes standard.
- Ductile Iron sleeves with extra thick cylinder walls promote excellent ring seal.
- Reinforcing ribs strengthen the lifter valley and bell housing flange.
- Inboard valley head stud bosses improve head gasket sealing.
- Priority main oiling system delivers oil directly to the crankshaft bearings to enhance reliability at high engine speeds.
- Steel 4-Bolt main caps or Ductile Iron and optional Aluminum caps. Splayed outer bolts for extra strength.
- Dual bolt patterns for standard BBC and notched oil pans.
- HIP (Hot Isostatic Pressed) Casting.
- Parts kit included (PN 32000006 - see page 115).

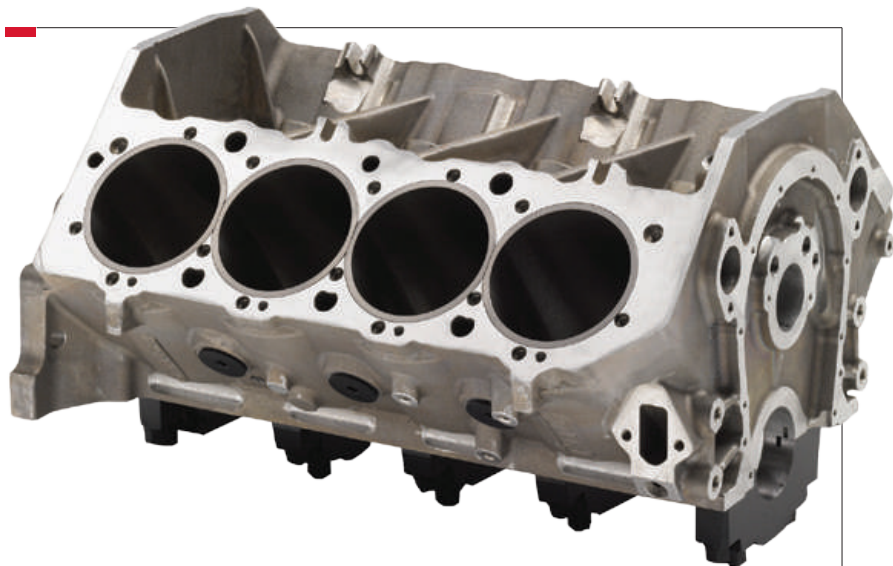

Dart blocks can be special ordered with a wide array of special machining options to suit your specific requirements.

## BIG M - ALUMINUM

PART NO.	CAPS	MAINS	CAM	DECK	BORE
31274344	Ductile	Std.	Std.	9.800"	4.250"
31274354	Ductile	Std.	Std.	10.200"	4.250"
31274444	Ductile	Std.	Std.	9.800"	4.500"
31274454	Ductile	Std.	Std.	10.200"	4.500"
31274644	Ductile	Std.	Std.	9.800"	4.600"
31274654	Ductile	Std.	Std.	10.200"	4.600"
<hr/>					
31264344	Steel	Std.	Std.	9.800"	4.250"
31264354	Steel	Std.	Std.	10.200"	4.250"
31264444	Steel	Std.	Std.	9.800"	4.500"
31264454	Steel	Std.	Std.	10.200"	4.500"
31264644	Steel	Std.	Std.	9.800"	4.600"
31264654	Steel	Std.	Std.	10.200"	4.600"

## BIG M ALUMINUM SPECS

Material:	RMR Cast Aluminum Alloy
Deck Height:	9.800" to 10.200"
Cylinder Bores:	4.250" to 4.600"
Main Bearings:	Standard
Main Caps:	Ductile or Steel
Cam Location:	Standard
Lifter Bores:	.842"
Freeze Plugs:	Screw-in
Rear Seal:	2-Piece
Weight:	140-160 lbs.





# BIG BLOCK CHEVY CAST ALUMINUM ENGINE BLOCKS

## QUICK INFO >>>

Dart's Race Series Aluminum big block is based on the Chevrolet big block V8 design, with added features like increased deck height and a raised cam location.

The camshaft is raised .400" above the stock location to increase clearance for the connecting rods and crankshaft counterweights. The main oil gallery is located alongside the camshaft tunnel to eliminate interference with the crank assembly.

Advanced engineering makes Dart Aluminum big blocks the choice for serious competition.

## FEATURES

- Premium alloy: Dart Aluminum blocks are cast from RMR Cast Aluminum alloy for superior strength and integrity.
- Standard 9.800" or 10.200" deck heights/options to 10.400".
- Raised camshaft location +.400" clears stroker crankshafts.
- Ductile Iron sleeves with extra thick cylinder walls promote excellent ring seal.
- Reinforcing ribs strengthen the lifter valley and bell housing flange.
- Inboard valley head stud bosses improve head gasket sealing.
- Priority main oiling system delivers oil directly to the crankshaft bearings to enhance reliability at high engine speeds.
- With or without distributor provision.
- Steel 4-bolt main caps or Ductile Iron and optional Aluminum caps. Splayed outer bolts for extra strength.
- Dual bolt patterns for standard BBC and notched oil pans.
- HIP (Hot Isostatic Pressed) Casting.
- Parts kit included (PN 32000006 - see page 115).

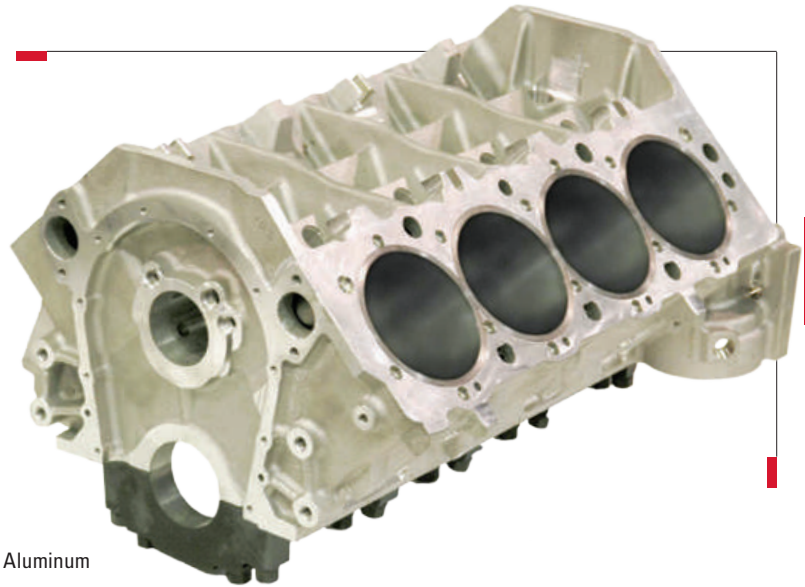

Dart blocks can be special ordered with a wide array of special machining options to suit your specific requirements.



## ALUMINUM TIMING CHAIN COVER

**PN 67240002**

For +.400" Raised Cam Block (includes gasket).

## RACE SERIES - ALUMINUM

PART NO.	CAPS	DECK	CAM	LIFTERS	BORE
31264345	Steel	9.800"	Std.	.842"	4.250"
31264445	Steel	9.800"	Std.	.842"	4.500"
31264645	Steel	9.800"	Std.	.842"	4.600"
31264385	Steel	10.000"	Std.	.842"	4.250"
31264485	Steel	10.000"	Std.	.842"	4.500"
31264685	Steel	10.000"	Std.	.842"	4.600"
31264355	Steel	10.200"	Std.	.842"	4.250"
31264455	Steel	10.200"	Std.	.842"	4.500"
31264655	Steel	10.200"	Std.	.842"	4.600"
31264395	Steel	10.400"	Std.	.842"	4.250"
31264495	Steel	10.400"	Std.	.842"	4.500"
31264695	Steel	10.400"	Std.	.842"	4.600"

## RACE SERIES SPECS

Material: RMR Cast Aluminum Alloy  
 Deck Height: 9.800" to 10.400"  
 Cylinder Bores: 4.250" to 4.600"  
 Oil Pan Rails: Stock  
 Main Caps: Steel  
 Cam Location: Raised +.400"  
 Lifter Bores: .842"  
 Freeze Plugs: Screw-in  
 Rear Seal: 2-Piece  
 Weight: 136-168 lbs.

BILLET

HON

SBF

BBC

LS

SBC

ACCESS

MANIFOLDS

HEADS

BLOCKS

TOP END KITS

SHORT BLOCKS



**24°**  
**308/345cc**

# BIG BLOCK CHEVY CAST IRON CYLINDER HEADS

## QUICK INFO >>>

**308cc** - Street and marine performance, mild bracket racing. Under 7,000 RPM, under 500 cubic inches excellent mid-range torque and power, good for heavier vehicles.

**345cc** - Maximum street or marine performance, bracket racing, heads up and super classes. Over 7,000 RPM, 540+ cubic inches.

Dart Iron Eagle 24° heads are an affordable alternative to more expensive Aluminum heads. High velocity runners produce incredible torque and power.

Long wearing Bronze valve guides, screw-in studs, multi-angle intake seats and hardened and radiused exhaust seats are standard. Best of all, our precision cast ports produce outstanding airflow without time consuming porting.

Assemblies include Stainless Steel valves, premium springs, locks, retainers, guide plates and seals.

**Heads are sold individually.**

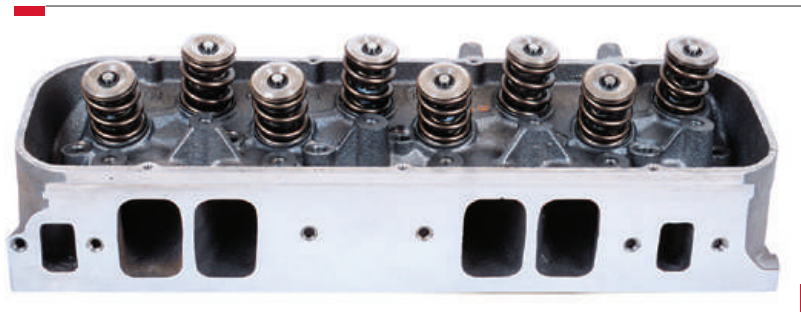

Head part kits - see pages 115.

Uses +.250" long intake valves.



## RECOMMENDED MANIFOLDS

### FOR 9.800" DECK BLOCKS

**41114000** Single Plane 4150  
**41124000** Single Plane 4500

### FOR 10.200" DECK BLOCKS

**41115000** Single Plane 4150  
**41125000** Single Plane 4500

## IRON EAGLE 24° 308/345cc SPECS

Material:	220 BHN Cast Iron
Valve Angle:	24°
Intake Port Volume:	308/345cc
Intake Valve:	2.250"/2.300"
Exhaust Valve:	1.880"
Chamber Volume:	121cc
Intake Port Shape:	Rectangle
Exhaust Port Location:	.300" raised

## 308cc FLOW @ 28" WATER

LIFT	INTAKE	EXHAUST
.200"	157	136
.300"	232	175
.400"	291	210
.500"	325	233
.600"	347	249
.700"	359	258
.800"	363	266

## 345cc FLOW @ 28" WATER

LIFT	INTAKE	EXHAUST
.200"	158	136
.300"	228	175
.400"	289	210
.500"	327	233
.600"	358	249
.700"	378	258
.800"	390	266

## IRON EAGLE 24° 308cc - IRON

PART NO.	CONFIGURATION FOR USE	MAX. LIFT
15100010	Bare Head	
15100111	1.550" Single Springs for Hydraulic Flat Tappet Cam	.700"
15100112	1.550" Dual Springs for Solid Roller	.700"
15100116	1.625" Dual Springs for Solid Roller Cam	.850"

## IRON EAGLE 24° 308cc - Iron [Marine w/ Inconel Valves]

PART NO.	CONFIGURATION FOR USE	MAX. LIFT
15100112M	1.550" Dual Springs for Hydraulic Roller	.700"

## IRON EAGLE 24° 345cc - IRON

PART NO.	CONFIGURATION FOR USE	MAX. LIFT
15200030	Bare Head	
15200132	1.550" Dual Springs for Solid Roller	.700"
15200136	1.625" Dual Springs for Solid Roller Cam	.850"

## IRON EAGLE 24° 345cc - Iron [Marine w/ Inconel Valves]

PART NO.	CONFIGURATION FOR USE	MAX. LIFT
15200132M	1.550" Dual Springs for Hydraulic Roller	.700"



# 24° 330/365cc CNC

# BIG BLOCK CHEVY CAST IRON CYLINDER HEADS

### QUICK INFO >>>

Maximum performance, bracket racing, heads up and super classes. Over 7,500 RPM, 500+ cubic inches, great head for maximum effort competition or bracket cars.

Dart's legendary Iron Eagle cylinder heads are now available with a full CNC porting treatment. Every intake port, every exhaust port and every combustion chamber are fully CNC machined on Dart's computerized 5-axis CNC machining centers.

The new Iron Eagle CNC cylinder head has 330cc runners and 126cc chambers with 2.30" intake and 1.88" exhaust valves, providing the power and consistency of ported heads in a rugged and affordable Cast Iron package. They are ideal for heavier cars or boats where weight is not a primary concern, and for racing classes which mandate Iron heads.

Assemblies include Stainless Steel valves, premium springs, locks, retainers, guide plates and seals.

**Heads are sold individually.**

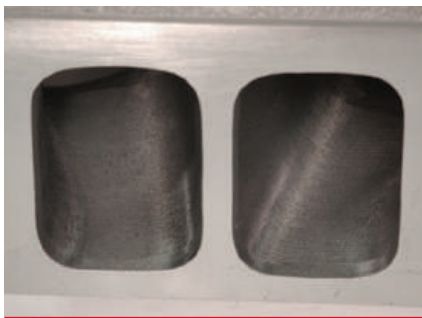

Head part kits - see pages 115.

Uses +.250" long intake valves.

### IRON EAGLE 24° 330cc CNC SPECS

Material:	220 BHN Cast Iron
Valve Angle:	24°
Intake Port Volume:	330cc CNC
Intake Valve:	2.300"
Exhaust Valve:	1.880"
Chamber Volume:	126cc
Intake Port Shape:	Rectangle
Exhaust Port Location:	.300" raised

### IRON EAGLE 24° 365cc CNC SPECS

Material:	High Nickel 220 BHN Cast Iron
Valve Angle:	24°
Intake Port Volume:	365cc CNC
Intake Valve:	2.350"
Exhaust Valve:	1.850"
Chamber Volume:	126cc
Intake Port Shape:	Rectangle
Exhaust Port Location:	.300" raised

### IRON EAGLE 24° 330cc CNC - IRON

PART NO.	CONFIGURATION FOR USE	MAX. LIFT
15370030	Bare Head	
15372131	1.550" Single Springs for Hydraulic Flat Tappet Cam	.700"
15372132	1.550" Dual Springs for Solid Roller	.700"
15372136	1.625" Dual Springs for Solid Roller Cam	.850"

### IRON EAGLE 24° 365cc CNC - IRON

PART NO.	CONFIGURATION FOR USE	MAX. LIFT
15872080	Bare Head	
15872186	1.625" Dual Springs for Solid Roller Cam	.850"
15872189	1.650" Triple Springs for Solid Roller Cam	.900"

### FLOW DATA @ 28" WATER

	330cc	330cc	365cc	365cc
LIFT	INTAKE	EXHAUST	INTAKE	EXHAUST
.200"	169	136	171	132
.300"	236	181	248	171
.400"	297	218	310	240
.500"	343	248	362	273
.600"	367	271	405	290
.700"	384	294	414	300
.800"	394	308	428	307

BILLET  
HON  
SBF  
BBC  
LS  
SBC  
ACCESS  
MANIFOLDS  
HEADS  
BLOCKS  
TOP END KITS  
SHORT BLOCKS

**IRON  
EAGLE**
**GEN VII**

# BIG BLOCK CHEVY

## 8.1/8.8L CAST IRON CYLINDER HEADS

### QUICK INFO >>>

The GM 8.1 liter big block was used in numerous marine and truck applications. Up until now, there have been very limited options for upgrading its performance potential.

Dart has developed a whole new world of performance for the metric 8.1/8.8 liter style big block engine. New Cast Iron cylinder heads with improved high flowing port designs and efficient combustion chambers greatly enhance power and torque output.

Dart's Cast Iron cylinder heads for the Gen VII 8.1/8.8 liter style engines offer improved ports and chambers as well as added valve train versatility.

We have introduced the only carburetor style intake manifold for these engines currently available. This dual plane Cast Aluminum unit offers new performance possibilities.

*Heads are sold individually.*



### RECOMMENDED MANIFOLD

See page 93

**41616010**  
8.1L Dual Plane



### IRON EAGLE GEN VII (8.1 LITER) SPECS

Material:	220 BHN Cast Iron
Valve angle:	24°
Intake Port Volume:	320cc
Intake Valve:	2.190"
Exhaust Valve:	1.880"
Chamber Volume:	108cc
Plug Type:	Angle

### FLOW DATA @ 28" WATER

LIFT	INTAKE	EXHAUST
.200"	159	131
.300"	221	178
.400"	271	211
.500"	312	237
.600"	345	255

### IRON EAGLE GEN VII (8.1/8.8 LITER) HEAD - IRON

PART NO.	MATERIAL	INTAKE PORT	CHAMBER	INTK/EXH	NOTES
15400170	Iron	320cc	108cc	2.190"/1.880"	Bare

### IRON EAGLE GEN VII DUAL PLANE MANIFOLD - ALUMINUM

PART NO.	MATERIAL	STYLE	CARB	NOTES
41616010	Aluminum	Dual Plane	4150	5/16" bolts





**24°  
275cc  
OVAL PORT**

# BIG BLOCK CHEVY CAST ALUMINUM CYLINDER HEADS

### QUICK INFO >>>

For street performance, mild bracket racing and marine. Under 6,800 RPM, under 500 cubic inches. Excellent mid-range torque and power, good for heavier vehicles.

A new high velocity oval port design makes this head an ideal choice for street cars and trucks. The PRO1's race proven features include rolled valve angles, improved spark plug location, extra long intake valves, raised exhaust ports, and fast burn chambers.

Long wearing Bronze valve guides, screw-in studs, multi-angle intake seats with hardened, radiused exhaust seats are standard. Best of all, our precision cast ports produce outstanding airflow without time consuming porting.

Assemblies include Stainless Steel valves, premium springs, locks, retainers, guide plates and seals.

**110cc chamber heads available upon request.**

**Heads are sold individually.**

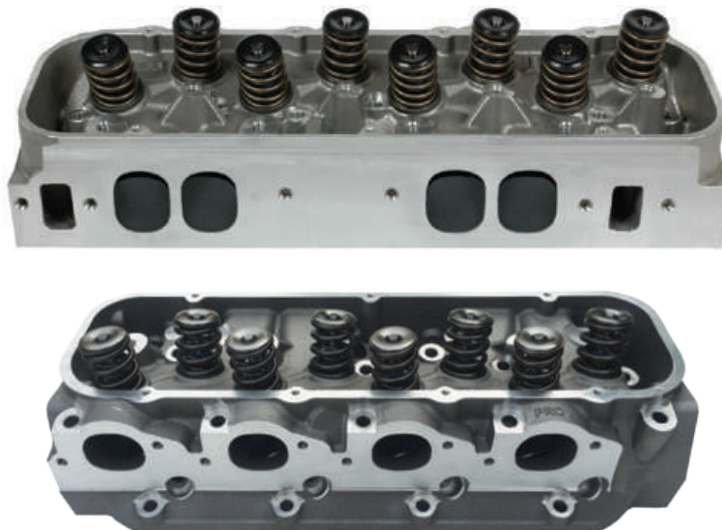

### DART MARINE PRO1 CYLINDER HEADS

Features an exclusive Teflon® surface finish to inhibit corrosion and extend the life of the head.

Fitted with Inconel exhaust valves to withstand the extended running time and temperatures typical of marine usage.

Head part kits - see pages 115.

Uses +.250" long intake valves.

### RECOMMENDED MANIFOLDS

#### FOR 9.800" DECK BLOCKS

- 41214000 Single Plane 4150
- 41224000 Single Plane 4500

#### FOR 10.200" DECK BLOCKS

- 41215000 Single Plane 4150
- 41225000 Single Plane 4500

### PRO1 24° 275cc SPECS

Material:	RMR Cast Aluminum Alloy
Valve Angle:	24°
Intake Port Volume:	275cc
Intake Valve:	2.190"/2.250"
Exhaust Valve:	1.880"
Chamber Volume:	110cc or 121cc
Intake Port Shape:	Oval
Exhaust Port Location:	.300" raised

### PRO1 24° 275cc - Aluminum [w/ 2.190" Intake Valve]

PART NO.	CONFIGURATION FOR USE	MAX. LIFT
19000070	Bare Head	
19000171	1.550" Single Springs for Hydraulic Flat Tappet Cam	.700"
19000172	1.550" Dual Springs for Solid Roller	.700"

### PRO1 24° 275cc - Aluminum [w/ 2.250" Intake Valve]

PART NO.	CONFIGURATION FOR USE	MAX. LIFT
19000010	Bare Head	
19000111	1.550" Single Springs for Hydraulic Flat Tappet Cam	.700"
19000112	1.550" Dual Springs for Solid Roller	.700"
19000116	1.625" Dual Springs for Solid Roller Cam	.850"

### PRO1 24° 275cc - Aluminum [Marine Heads w/ 2.190" Intake Valve]

PART NO.	CONFIGURATION FOR USE	MAX. LIFT
19000070M	Bare Head	
19000172M	1.550" Dual Springs for Hydraulic Roller Cam	.700"

### PRO1 24° 275cc - Aluminum [Marine Heads w/ 2.250" Intake Valve]

PART NO.	CONFIGURATION FOR USE	MAX. LIFT
19000010M	Bare Head	
19000112M	1.550" Dual Springs for Hydraulic Roller Cam	.700"

### FLOW DATA @ 28" WATER

LIFT	INTAKE	EXHAUST
.200"	154	127
.300"	225	170
.400"	284	211
.500"	318	244
.600"	341	267
.700"	352	282

BILLET  
HON  
SBF  
BBC  
LS  
SBC  
ACCESS  
MANIFOLDS  
HEADS  
BLOCKS  
TOP END KITS  
SHORT BLOCKS



# 24° 310cc BIG BLOCK CHEVY CAST ALUMINUM CYLINDER HEADS

## QUICK INFO >>>

For street performance and mild bracket racing. Under 7,000 RPM, under 500 cubic inches. Excellent mid-range torque and power, good for heavier vehicles.

Inspired by Dart's championship winning Pro Stock designs, the PRO1's race proven features include rolled valve angles, improved spark plug location, extra long intake valves, raised exhaust ports, and fast burn chambers - yet the PRO1 310cc can be used with off the shelf pistons, valve train components, and intake manifolds.

Long wearing Bronze valve guides, screw-in studs, multi-angle intake seats with hardened, radiused exhaust seats are standard. Best of all, our precision cast ports produce outstanding airflow without time consuming porting.

Assemblies include Stainless Steel valves, premium springs, locks, retainers, guide plates and seals.

**Heads are sold individually.**



### DART MARINE PRO1 CYLINDER HEADS

Features an exclusive Teflon® surface finish to inhibit corrosion and extend the life of the head.

Fitted with Inconel exhaust valves to withstand the extended running time and temperatures typical of marine usage.



Head part kits - see pages 115.

Uses +.250" long intake valves.

## RECOMMENDED MANIFOLDS

### FOR 9.800" DECK BLOCKS

41114000 Single Plane 4150  
41124000 Single Plane 4500

### FOR 10.200" DECK BLOCKS

41115000 Single Plane 4150  
41125000 Single Plane 4500

## PRO1 24° 310cc SPECS

Material: RMR Cast Aluminum Alloy  
Valve Angle: 24°  
Intake Port Volume: 310cc  
Intake Valve: 2.250"/2.300"  
Exhaust Valve: 1.880"  
Chamber Volume: 121cc  
Intake Port Shape: Rectangle  
Exhaust Port Location: .300" raised

## FLOW DATA @ 28" WATER

LIFT	INTAKE	EXHAUST
.200"	167	127
.300"	250	170
.400"	302	211
.500"	333	244
.600"	352	267
.700"	360	282
.800"	363	294

## PRO1 24° 310cc - ALUMINUM [w/ 2.250" Intake Valve]

PART NO.	CONFIGURATION FOR USE	MAX. LIFT
19100010	Bare Head	
19100111	1.550" Single Springs for Hydraulic Flat Tappet Cam	.700"
19100112	1.550" Dual Springs for Solid Roller	.700"
19100116	1.625" Dual Springs for Solid Roller Cam	.850"

## PRO1 24° 310cc - Aluminum [w/ 2.300" Intake Valve]

PART NO.	CONFIGURATION FOR USE	MAX. LIFT
19100030	Bare Head	
19100132	1.550" Dual Springs for Solid Roller	.700"
19100136	1.625" Dual Springs for Solid Roller Cam	.850"

## PRO1 24° 310cc - Aluminum [Marine Heads w/ 2.190" Intake Valve]

PART NO.	CONFIGURATION FOR USE	MAX. LIFT
19100070M	Bare Head	

## PRO1 24° 310cc - Aluminum [Marine Heads w/ 2.250" Intake Valve]

PART NO.	CONFIGURATION FOR USE	MAX. LIFT
19100010M	Bare Head	
19100112M	1.550" Dual Springs for Hydraulic Roller Cam	.700"

## PRO1 24° 310cc - Aluminum [Marine Heads w/ 2.300" Intake Valve]

PART NO.	CONFIGURATION FOR USE	MAX. LIFT
19100030M	Bare Head	
19100132M	1.550" Dual Springs for Hydraulic Roller Cam	.700"



**24°  
325cc**

# BIG BLOCK CHEVY CAST ALUMINUM CYLINDER HEADS

### QUICK INFO >>>

*Serious street performance, mild bracket racing, and marine. Over 7,000 RPM, 525+ cubic inches. Can be used on smaller engines with a tight converter.*

The PRO1 24° 325cc delivers increased airflow at high valve lift for high RPM, big cubic inch engines, and still remains compatible with off the shelf pistons, valve train components, and intake manifolds.

Long wearing Bronze valve guides, screw-in studs, multi-angle intake seats with hardened, radiused exhaust seats are standard. Best of all, our precision cast ports produce outstanding airflow without time consuming porting.

Assemblies include Stainless Steel valves, premium springs, locks, retainers, guide plates and seals.

**Heads are sold individually.**

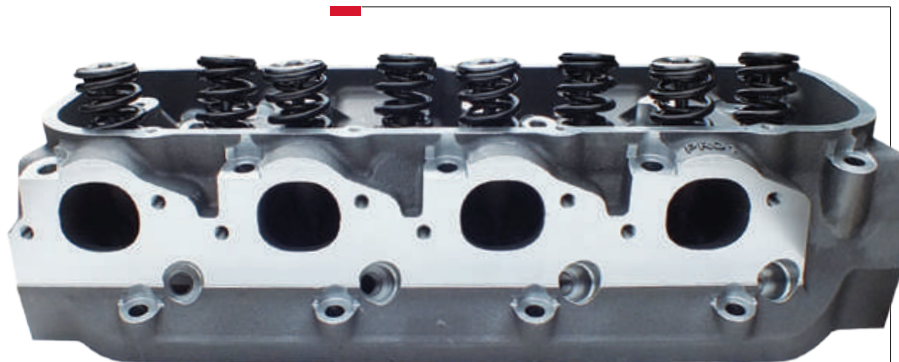

### DART MARINE PRO1 CYLINDER HEADS

Features an exclusive Teflon® surface finish to inhibit corrosion and extend the life of the head.

Fitted with Inconel exhaust valves to withstand the extended running time and temperatures typical of marine usage.

Head parts kit - see page 115.

Uses +.250" long intake valves.

### RECOMMENDED MANIFOLDS

#### FOR 9.800" DECK BLOCKS

- 41114000** Single Plane 4150
- 41124000** Single Plane 4500

#### FOR 10.200" DECK BLOCKS

- 41115000** Single Plane 4150
- 41125000** Single Plane 4500

### PRO1 24° 325cc SPECS

Material:	RMR Cast Aluminum Alloy
Valve Angle:	24°
Intake Port Volume:	325cc
Intake Valve:	2.250"/2.300"
Exhaust Valve:	1.880"
Chamber Volume:	121cc
Intake Port Shape:	Rectangle
Exhaust Port Location:	.300" raised

### FLOW DATA @ 28" WATER

LIFT	INTAKE	EXHAUST
.200"	166	127
.300"	245	170
.400"	297	211
.500"	330	244
.600"	355	267
.700"	370	282
.800"	377	294

### PRO1 24° 325cc - ALUMINUM [w/ 2.250" Intake Valve]

PART NO.	CONFIGURATION FOR USE	MAX. LIFT
19200010	Bare Head	
19200111	1.550" Single Springs for Hydraulic Flat Tappet Cam	.700"
19200112	1.550" Dual Springs for Solid Roller	.700"
19200116	1.625" Dual Springs for Solid Roller Cam	.850"

### PRO1 24° 325cc - ALUMINUM [w/ 2.300" Intake Valve]

PART NO.	CONFIGURATION FOR USE	MAX. LIFT
19200030	Bare Head	
19200132	1.550" Dual Springs for Solid Roller	.700"
19200136	1.625" Dual Springs for Solid Roller Cam	.850"

### PRO1 24° 325cc - ALUMINUM [Marine Heads w/ 2.250" Intake Valve]

PART NO.	CONFIGURATION FOR USE	MAX. LIFT
19200010M	Bare Head	
19200112M	1.550" Dual Springs for Hydraulic Roller Cam	.700"

### PRO1 24° 325cc - ALUMINUM [Marine Heads w/ 2.300" Intake Valve]

PART NO.	CONFIGURATION FOR USE	MAX. LIFT
19200030M	Bare Head	
19200132M	1.550" Dual Springs for Hydraulic Roller Cam	.700"

BILLET  
HON  
SBF  
BBC  
LS  
SBC  
ACCESS  
MANIFOLDS  
HEADS  
BLOCKS  
TOP END KITS  
SHORT BLOCKS

**24°  
345cc**

# BIG BLOCK CHEVY CAST ALUMINUM CYLINDER HEADS

## QUICK INFO >>>

Maximum street or marine performance, bracket racing, heads up and super classes. Over 7,000 RPM, 540+ cubic inches.

The PRO1 24° 345cc cylinder head is for uncompromising performance and racing applications which favor high RPM power over low end flexibility. Best for big cubic inch, high RPM use.

Rolled valve angles, improved spark plug location, extra long intake valves, raised exhaust ports, and fast burn chambers. Works with off the shelf pistons, valve train components, and intake manifolds.

Long wearing Bronze valve guides, screw-in studs, multi-angle intake seats with hardened, radiused exhaust seats are standard.

Assemblies include Stainless Steel valves, premium springs, locks, retainers, guide plates and seals.

*Heads are sold individually.*

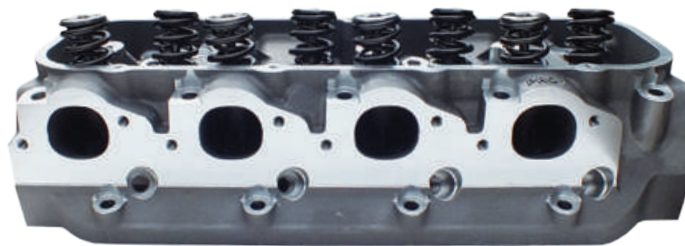

Head parts kit - see page 115.

Uses +.250" long intake valves.

## RECOMMENDED MANIFOLDS

### FOR 9.800" DECK BLOCKS

41114000 Single Plane 4150  
41124000 Single Plane 4500

### FOR 10.200" DECK BLOCKS

41115000 Single Plane 4150  
41125000 Single Plane 4500

## PRO1 24° 345cc SPECS

Material:	RMR Cast Aluminum Alloy
Valve Angle:	24°
Intake Port Volume:	345cc
Intake Valve:	2.300"
Exhaust Valve:	1.880"
Chamber Volume:	121cc
Intake Port Shape:	Rectangle
Exhaust Port Location:	.300" raised

## FLOW DATA @ 28" WATER

LIFT	INTAKE	EXHAUST
.200"	165	127
.300"	244	170
.400"	308	211
.500"	355	244
.600"	378	267
.700"	396	282
.800"	399	294



## DART MARINE PRO1 CYLINDER HEADS

Features an exclusive Teflon® surface finish to inhibit corrosion and extend the life of the head.

Fitted with Inconel exhaust valves to withstand the extended running time and temperatures typical of marine usage.

## PRO1 24° 345cc - ALUMINUM

PART NO.	CONFIGURATION FOR USE	MAX. LIFT
19300030	Bare Head	
19300132	1.550" Dual Springs for Solid Roller	.700"
19300136	1.625" Dual Springs for Solid Roller Cam	.850"

## PRO1 24° 345cc - ALUMINUM [Marine Heads]

PART NO.	CONFIGURATION FOR USE	MAX. LIFT
19300030M	Bare Head	
19300132M	1.550" Dual Springs for Hydraulic Roller Cam	.700"





**24°**  
**525 MMR**  
**310/325/345cc**

# BIG BLOCK CHEVY CAST ALUMINUM CYLINDER HEADS

### QUICK INFO >>>

Mercury Racing 525 replacement style heads. Three intake runner sizes offer potential for increased levels of performance.

We've retooled Dart's PRO1 BBC castings to produce a true bolt on upgrade for the Mercury Racing 525 engine. The PRO1 24° 525 MMR is available with 310cc, 325cc or 345cc intake runners and has the correct exhaust bolt pattern for the factory manifolds. A grey chromate surface treatment inhibits salt corrosion for marine usage.

Heads are sold individually.



### DART MARINE PRO1 CYLINDER HEADS

Features an exclusive Teflon® surface finish to inhibit corrosion and extend the life of the head.

Fitted with Inconel exhaust valves to withstand the extended running time and temperatures typical of marine usage.

Head parts kit - see page 115.

Uses +.250" long intake valves.

### RECOMMENDED MANIFOLDS

#### FOR 9.800" DECK BLOCKS

- 41114000 Single Plane 4150
- 41124000 Single Plane 4500

### PRO1 24° 310cc MERC STYLE - ALUMINUM [w/ 2.250" Intake Valve]

PART NO.	CONFIGURATION FOR USE	MAX. LIFT
19100010MMR	Bare Head	
19100112MMR	1.550" Dual Springs for Hydraulic Roller Cam	.700"

### PRO1 24° 325cc MERC STYLE - ALUMINUM [w/ 2.250" Intake Valve]

PART NO.	CONFIGURATION FOR USE	MAX. LIFT
19200010MMR	Bare Head	
19200112MMR	1.550" Dual Springs for Hydraulic Roller Cam	.700"

### PRO1 24° 325cc MERC STYLE - ALUMINUM [w/ 2.300" Intake Valve]

PART NO.	CONFIGURATION FOR USE	MAX. LIFT
19200030MMR	Bare Head	
19200132MMR	1.550" Dual Springs for Hydraulic Roller Cam	.700"

### PRO1 24° 345cc MERC STYLE - ALUMINUM [w/ 2.300" Intake Valve]

PART NO.	CONFIGURATION FOR USE	MAX. LIFT
19300030MMR	Bare Head	
19300132MMR	1.550" Dual Springs for Hydraulic Roller Cam	.700"

### PRO1 24° 310cc MERC STYLE SPECS

Material:	RMR Cast Aluminum Alloy
Valve Angle:	24°
Intake Port Volume:	310/325/345cc
Intake Valve:	2.250"/2.300"
Exhaust Valve:	1.880"
Chamber Volume:	121cc
Intake Port Shape:	Rectangle
Exhaust Port Location:	.300" raised

### 310cc FLOW DATA @ 28" WATER

LIFT	INTAKE	EXHAUST
.200"	167	127
.300"	250	170
.400"	302	211
.500"	333	244
.600"	352	267
.700"	360	282
.800"	363	294

### 325cc FLOW DATA @ 28" WATER

LIFT	INTAKE	EXHAUST
.200"	166	127
.300"	245	170
.400"	297	211
.500"	330	244
.600"	355	267
.700"	370	282
.800"	377	294

### 345cc FLOW DATA @ 28" WATER

LIFT	INTAKE	EXHAUST
.200"	165	127
.300"	244	170
.400"	308	211
.500"	355	244
.600"	378	267
.700"	396	282
.800"	399	294

BILLET

HON

SBF

BBC

LS

SBC

ACCESS

MANIFOLDS

HEADS

BLOCKS

TOP END KITS

SHORT BLOCKS



**24°  
335cc  
CNC**

## BIG BLOCK CHEVY CAST ALUMINUM CYLINDER HEADS

### QUICK INFO >>>

Maximum performance, bracket racing, heads up and super classes. Over 7,500 RPM, 500+ cubic inches, great head for maximum effort comp or bracket cars.

Dart PRO1 24° 335cc CNC heads are professional quality competition cylinder heads. We applied the airflow technology developed in our championship winning Pro Stock engine program to produce these state of the art heads.

Every intake port, exhaust runner, valve bowl, and every combustion chamber is 100% CNC machined in special dedicated PRO1 castings. Our 5-axis, computer controlled machining centers produce compound curves and complex shapes that no human could duplicate with a hand grinder.

Assemblies include Stainless Steel valves, premium springs, locks, retainers, guide plates and seals.

**Heads are sold individually.**

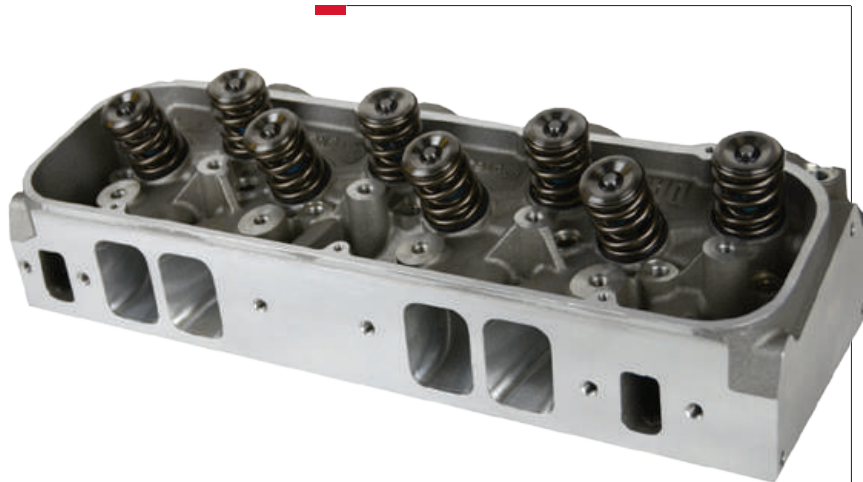

Head parts kit - see page 115.

Uses +.250" long intake valves.

### RECOMMENDED MANIFOLDS

#### FOR 9.800" DECK BLOCKS

41114000 Single Plane 4150  
41124000 Single Plane 4500

#### FOR 10.200" DECK BLOCKS

41115000 Single Plane 4150  
41125000 Single Plane 4500

### PRO1 24° 335cc CNC SPECS

Material:	RMR Cast Aluminum Alloy
Valve Angle:	24°
Intake Port Volume:	335cc
Intake Valve:	2.300"
Exhaust Valve:	1.880"
Chamber Volume:	121cc
Intake Port Shape:	Rectangle
Exhaust Port Location:	.300" raised

### FLOW DATA @ 28" WATER

LIFT	INTAKE	EXHAUST
.200"	174	136
.300"	245	178
.400"	306	235
.500"	353	265
.600"	383	282
.700"	401	296
.800"	406	303



### DART MARINE PRO1 CYLINDER HEADS

Features an exclusive Teflon® surface finish to inhibit corrosion and extend the life of the head.

Fitted with Inconel exhaust valves to withstand the extended running time and temperatures typical of marine usage.



### PRO1 24° 335cc CNC - ALUMINUM

PART NO.	CONFIGURATION FOR USE	MAX. LIFT
19474030	Bare Head	
19474136	1.625" Dual Springs for Solid Roller	.850"
19474139	1.650" Triple Springs for Solid Roller Cam	.900"

### PRO1 24° 335cc CNC - ALUMINUM [Marine Heads]

PART NO.	CONFIGURATION FOR USE	MAX. LIFT
19474030M	Bare Head	
19474136M	1.625" Dual Springs for Solid Roller	.850"



**24°  
355cc  
CNC**

# BIG BLOCK CHEVY CAST ALUMINUM CYLINDER HEADS

### QUICK INFO >>>

Maximum performance, bracket racing, heads up and super classes. Over 7,500 RPM, 540+ cubic inches, a great head for maximum effort comp or bracket cars.

The PRO1 24° 355cc CNC heads are for uncompromising performance and racing applications which favor high RPM power over low end flexibility. Best for big cubic inch, high RPM use.

Every intake port, exhaust runner, valve bowl, and every combustion chamber is 100% CNC machined on special dedicated PRO1 castings. Our 5-axis, computer controlled machining centers produce compound curves and complex shapes that no human could duplicate with a hand grinder.

Assemblies include Stainless Steel valves, premium springs, locks, retainers, guide plates and seals.

**Heads are sold individually.**

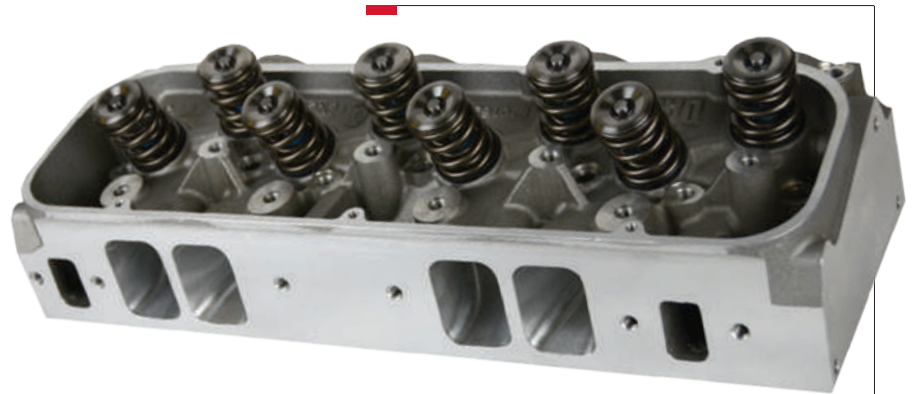

Head parts kit - see page 115.

Uses +.250" long intake valves.



### DART MARINE PRO1 CYLINDER HEADS

Features an exclusive Teflon® surface finish to inhibit corrosion and extend the life of the head.

Fitted with Inconel exhaust valves to withstand the extended running time and temperatures typical of marine usage.

### RECOMMENDED MANIFOLDS

#### FOR 9.800" DECK BLOCKS

- 41114000 Single Plane 4150
- 41124000 Single Plane 4500

#### FOR 10.200" DECK BLOCKS

- 41115000 Single Plane 4150
- 41125000 Single Plane 4500

### PRO1 24° 355cc CNC SPECS

Material:	RMR Cast Aluminum Alloy
Valve Angle:	24°
Intake Port Volume:	355cc CNC
Intake Valve:	2.300"
Exhaust Valve:	1.880"
Chamber Volume:	121cc
Intake Port Shape:	Rectangle
Exhaust Port Location:	.300" raised

### PRO1 24° 355cc CNC - ALUMINUM

PART NO.	CONFIGURATION FOR USE	MAX. LIFT
19574030	Bare Head	
19574136	1.625" Dual Springs for Solid Roller	.850"
19574139	1.650" Triple Springs for Solid Roller Cam	.900"

### PRO1 24° 355cc CNC - ALUMINUM [Marine Heads]

PART NO.	CONFIGURATION FOR USE	MAX. LIFT
19574030M	Bare Head	
19574136M	1.625" Dual Springs for Solid Roller	.850"

### FLOW DATA @ 28" WATER

LIFT	INTAKE	EXHAUST
.200"	177	136
.300"	251	178
.400"	310	235
.500"	360	265
.600"	399	282
.700"	402	296
.800"	426	303

BILLET

HON

SBF

BBC

LS

SBC

ACCESS

MANIFOLDS

HEADS

BLOCKS

TOP END KITS

SHORT BLOCKS



**24°  
365cc  
CNC**

# BIG BLOCK CHEVY CAST ALUMINUM CYLINDER HEADS

## QUICK INFO >>>

Maximum performance, bracket racing, heads up and super classes. 7,500 RPM, 540+ cubic inches, great head for maximum effort, comp or bracket cars.

The PRO1 24° 365cc CNC is for uncompromising performance and racing applications which favor high RPM power over low end flexibility. Best for big cubic inch, high RPM use.

Every intake port, exhaust runner, valve bowl, and every combustion chamber is 100% CNC machined on special dedicated PRO1 castings. Our 5-axis, computer controlled machining centers produce compound curves and complex shapes that no human could duplicate with a hand grinder.

Assemblies include Stainless Steel valves, premium springs, locks, retainers, guide plates and seals.

**Heads are sold individually.**



Head parts kit - see page 115.

Uses +.350" long intake valves.

## RECOMMENDED MANIFOLDS

### FOR 9.800" DECK BLOCKS

41114000 Single Plane 4150  
41124000 Single Plane 4500

### FOR 10.200" DECK BLOCKS

41115000 Single Plane 4150  
41125000 Single Plane 4500

## PRO1 24° 365cc CNC SPECS

Material:	RMR Cast Aluminum Alloy
Valve Angle:	24°
Intake Port Volume:	365cc CNC
Intake Valve:	2.350"
Exhaust Valve:	1.850"
Chamber Volume:	121cc
Intake Port Shape:	Rectangle
Exhaust Port Location:	.300" raised

## FLOW DATA @ 28" WATER

LIFT	INTAKE	EXHAUST
.200"	171	132
.300"	248	171
.400"	310	240
.500"	362	273
.600"	405	290
.700"	414	300
.800"	428	307



## DART MARINE PRO1 CYLINDER HEADS

Features an exclusive Teflon® surface finish to inhibit corrosion and extend the life of the head.

Fitted with Inconel exhaust valves to withstand the extended running time and temperatures typical of marine usage.



## PRO1 24° 365cc CNC - ALUMINUM

PART NO.	CONFIGURATION FOR USE	MAX. LIFT
19874080	Bare head	
19874186	1.625" Dual Springs for Solid Roller	.850"
19874189	1.650" Triple Springs for Solid Roller Cam	.900"

## PRO1 24° 365cc CNC - ALUMINUM [Marine Heads]

PART NO.	CONFIGURATION FOR USE	MAX. LIFT
19874080M	Bare head	
19874186M	1.625" Dual Springs for Solid Roller	.850"



**20°  
440cc**

# BIG BLOCK CHEVY CAST ALUMINUM CYLINDER HEADS

### QUICK INFO >>>

Maximum competition, high torque, high compression  
- low dome. 8000+ RPM, 500+ cubic inches.

Dart developed the first successful aftermarket aluminum heads for the big block Chevy engine platform and we've done it again! We have continued to refine our revolutionary designs through our in house research and development program and now offer the latest of our advancements in the PRO1 20° 440cc Aluminum cylinder heads.

The Dart PRO1 20° heads deliver superior performance, by utilizing 440cc runners in a raised asymmetrical port design, and feature a 20° rolled valve angle with redesigned shallow combustion chambers. These heads are ideal for maximum effort naturally aspirated, big boost forced induction, or nitrous applications.

- **Designed to use conventional BBC intake manifolds.**
- **Requires use of shaft mounted rockers.**
- **Requires special pistons.**
- **HIP (Hot Isostatic Pressed) Casting.**
- **Solid heads available by special order.**
- **MUST use Copper seats with Titanium Valves.**
- **Heads are sold individually.**

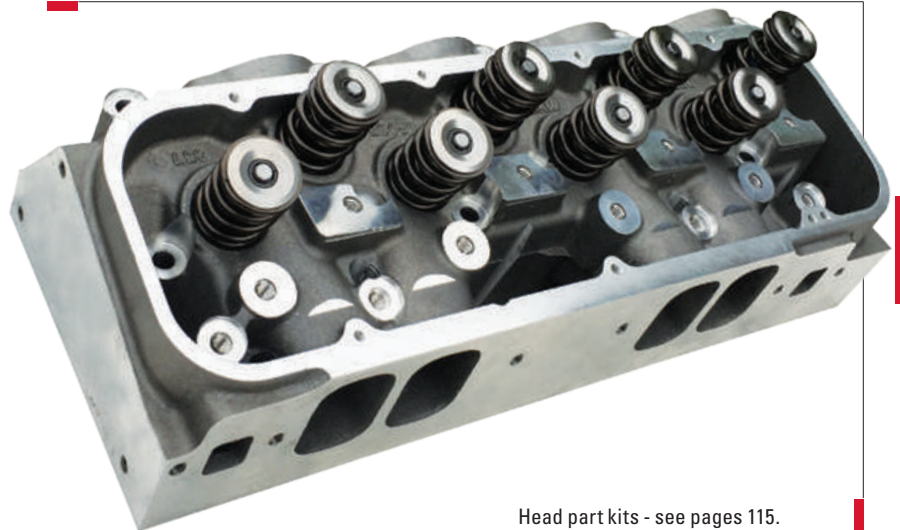

Head part kits - see pages 115.

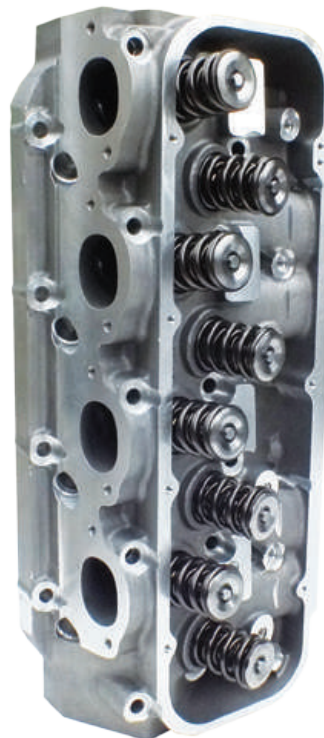

### RECOMMENDED MANIFOLDS

#### FOR 9.800" DECK BLOCKS

- 62220010 End Rail Spacers **\*REQUIRED**
- 41114000 Single Plane 4150
- 41124000 Single Plane 4500

#### FOR 10.200" DECK BLOCKS

- 62220011 End Rail Spacers **\*REQUIRED**
- 41115000 Single Plane 4150
- 41125000 Single Plane 4500

### PRO1 20° 440cc SPECS

Material:	RMR Cast Aluminum Alloy
Valve Angle:	20°
Intake Port Volume:	440cc
Intake Valve:	2.400"
Exhaust Valve:	1.800"
CNC Chamber Volume:	97cc
Intake Port Shape:	Rectangle
Exhaust Port Location:	.500" raised

### FLOW DATA @ 28" WATER

LIFT	INTAKE	EXHAUST
.200"	156	133
.300"	242	181
.400"	321	224
.500"	388	257
.600"	425	284
.700"	448	306
.800"	452	321
.900"	460	326
1.000"	467	333

### PRO1 20° 440cc - ALUMINUM

PART NO.	CONFIGURATION	MAX. LIFT
19705090	Bare head	
19705196	1.625" Solid Roller Cam	.850"
19705199	1.650" Triple Springs for Solid Roller Cam	.900"

BILLET

HON

SBF

BBC

LS

SBC

ACCESS

MANIFOLDS

HEADS

BLOCKS

TOP END KITS

SHORT BLOCKS

# 20° 451cc CNC

## BIG BLOCK CHEVY CAST ALUMINUM CYLINDER HEADS

### QUICK INFO >>>

Maximum competition, high torque, high compression  
- low dome. 8000+ RPM, 500+ cubic inches.

Dart developed the first successful aftermarket aluminum heads for the big block Chevy engine platform and we've done it again! We have continued to refine our revolutionary designs through our in house research and development program and now offer the latest of our advancements in the PRO1 20° 451cc CNC Aluminum cylinder heads.

The Dart PRO1 20° heads deliver superior performance, by utilizing 451cc runners in a raised asymmetrical port design, and feature a 20° rolled valve angle with redesigned shallow combustion chambers. These heads are ideal for maximum effort naturally aspirated, big boost forced induction, or nitrous applications.

- **Designed to use conventional BBC intake manifolds.**
- **Requires use of shaft mounted rockers.**
- **Requires special pistons.**
- **HIP (Hot Isostatic Pressed) Casting.**
- **Solid heads available by special order.**
- **MUST use Copper seats with Titanium Valves.**
- **Heads are sold individually.**



Head part kits - see pages 115.

### RECOMMENDED MANIFOLDS

#### FOR 9.800" DECK BLOCKS

62220010	End Rail Spacers <b>*REQUIRED</b>
41114000	Single Plane 4150
41124000	Single Plane 4500

#### FOR 10.200" DECK BLOCKS

62220011	End Rail Spacers <b>*REQUIRED</b>
41115000	Single Plane 4150
41125000	Single Plane 4500

### PRO1 20° 451cc CNC SPECS

Material:	RMR Cast Aluminum Alloy
Valve Angle:	20°
Intake Port Volume:	451cc CNC
Intake Valve:	2.400"
Exhaust Valve:	1.800"
CNC Chamber Volume:	97cc
Intake Port Shape:	Rectangle
Exhaust Port Location:	.500" raised

### FLOW DATA @ 28" WATER

LIFT	INTAKE	EXHAUST
.200"	176	145
.300"	250	197
.400"	309	237
.500"	375	273
.600"	429	300
.700"	460	326
.800"	479	342
.900"	486	351
1.000"	489	357

### PRO1 20° 451cc CNC - ALUMINUM

PART NO.	CONFIGURATION	MAX. LIFT
19770000	C-Core	
19775090	Bare head	
19775196	1.625" Dual Springs for Solid Roller Cam	.850"
19775199	1.650" Triple Springs for Solid Roller Cam	.900"

BILLET

HON

SBF

BBC

LS

SBC

ACCESS

MANIFOLDS

HEADS

BLOCKS

TOP END KITS

SHORT BLOCKS



**24°  
380cc  
CNC**

# BIG BLOCK CHEVY CAST ALUMINUM CYLINDER HEADS

### QUICK INFO >>>

Maximum performance, bracket racing, heads up and super classes. Over 7,500 RPM, 500+ cubic inches, a great head for maximum effort comp or bracket cars.

Dart's PRO2 24° 380cc CNC heads have been revised with larger 2.350" intake valves and a revised port design for improved airflow and a substantial horsepower increase!

These cylinder heads were designed to make competitive engine building easier and less expensive by incorporating the rugged features of our famous Race Series casting into a ready to use, professional quality competition cylinder head. Every intake port, every exhaust runner, every valve bowl, and every combustion chamber is 100% digitally CNC machined for the ultimate in consistency.

Assemblies include Stainless Steel valves, premium springs, locks, retainers, guide plates and seals.

*Heads are sold individually.*



### DART MARINE PRO1 CYLINDER HEADS

Features an exclusive Teflon® surface finish to inhibit corrosion and extend the life of the head.

Fitted with Inconel exhaust valves to withstand the extended running time and temperatures typical of marine usage.



Head part kits - see pages 115.

Uses +.350" long intake valves.

### RECOMMENDED MANIFOLDS

#### FOR 9.800" DECK BLOCKS

- 41114000 Single Plane 4150
- 41124000 Single Plane 4500

#### FOR 10.200" DECK BLOCKS

- 41115000 Single Plane 4150
- 41125000 Single Plane 4500

### PRO2 24° 380cc CNC SPECS

Material:	RMR Cast Aluminum Alloy
Valve Angle:	24°
Intake Port Volume:	380cc CNC
Intake Valve:	2.300"/2.350"
Exhaust Valve:	1.880"/1.850"
Chamber Volume:	124cc
Intake Port Shape:	Rectangle
Exhaust Port Location:	.500" raised

### FLOW DATA @ 28" WATER

LIFT	INTAKE	EXHAUST
.200"	170	134
.300"	244	178
.400"	306	223
.500"	359	274
.600"	399	300
.700"	425	318
.800"	434	330
.900"	440	338

### PRO2 24° 380cc CNC - ALUMINUM

#### PRO2 24° 380cc CNC HEADS w/ 2.300"/1.880" VALVES

PART NO.	CONFIGURATION	MAX. LIFT
19674030	Bare Head	
19674136	1.625" Dual Springs for Solid Roller Cam	.850"
19674139	1.650 Triple Springs for Solid Roller Cam	.900"

#### PRO2 24° 380cc CNC HEADS w/ 2.350"/1.850" VALVES

PART NO.	CONFIGURATION	MAX. LIFT
19674080	Bare Head	
19674186	1.625" Dual Springs for Solid Roller Cam	.850"
19674189	1.650 Triple Springs for Solid Roller Cam	.900"

### PRO2 24° 380cc CNC - ALUMINUM [Marine Heads]

PART NO.	CONFIGURATION FOR USE	MAX. LIFT
19674030M	Bare head	

BILLET

HON

SBF

BBC

LS

SBC

ACCESS

MANIFOLDS

HEADS

BLOCKS

TOP END KITS

SHORT BLOCKS



# 24° 340/370cc OVAL PORT

# BIG BLOCK CHEVY CAST ALUMINUM CYLINDER HEADS

### QUICK INFO >>>

Maximum competition, performance marine and high torque, 8,000+ RPM, 500+ cubic inches.

Dart 340/370cc oval port Aluminum cylinder heads have high velocity 340/370cc intake runners that produce incredible midrange torque and throttle response. Oval port heads really "wake up" a big block in marine applications, or in a heavy car with an automatic transmission. They also work great in a light car with a tight torque converter.

Dart big block heads deliver superior performance without the hassles of welding and modifying stock castings. We applied proven Pro Stock technology to produce big block heads that out perform the competition, yet Dart heads can be used with most off the shelf pistons, manifolds, headers, and valve train components.

Heads are sold individually.



Head part kits - see pages 115.

Uses +.250" long intake valves.

### RECOMMENDED MANIFOLDS

#### FOR 9.800" DECK BLOCKS

41114000 Single Plane 4150\*  
41124000 Single Plane 4500\*

#### FOR 10.200" DECK BLOCKS

41115000 Single Plane 4150\*  
41125000 Single Plane 4500\*

(\*With slight porting modification)

### RACE SERIES 24° 340/370cc SPECS

Material: RMR Cast Aluminum Alloy  
Valve Angle: 24°  
Intake Port Volume: 340/370cc  
Intake Valve: 2.250"/2.300"  
Exhaust Valve: 1.880"  
Chamber Volume: 125cc  
Intake Port Shape: Oval  
Exhaust Port Location: .300" raised

### FLOW DATA @ 28" WATER

LIFT	INTAKE	EXHAUST
.200"	175	135
.300"	238	187
.400"	302	231
.500"	350	280
.600"	385	292
.700"	411	310
.800"	420	319

### RACE SERIES 24° 340cc - ALUMINUM [Oval Port Heads]

PART NO.	CONFIGURATION	CNC PORTING	INTAKE PORT VOL.	VALVES	SPRINGS	CYL. BORE
16776010	Bare Head	Full Port	340cc	2.250"/1.880"		4.500"
16776116	Assembly	Full Port	340cc	2.250"/1.880"	1.625"	4.500"
16777010	Bare Head	Full Port	340cc	2.250"/1.880"		4.600"
16777116	Assembly	Full Port	340cc	2.250"/1.880"	1.625"	4.600"

### RACE SERIES 24° 370cc - ALUMINUM [Oval Port Heads]

PART NO.	CONFIGURATION	CNC PORTING	INTAKE PORT VOL.	VALVES	SPRINGS	CYL BORE
16774030	Bare Head	Full Port	370cc	2.300"/1.880"		4.500"
16774136	Assembly	Full Port	370cc	2.300"/1.880"	1.625"	4.500"
16775030	Bare Head	Full Port	370cc	2.300"/1.880"		4.600"
16775136	Assembly	Full Port	370cc	2.300"/1.880"	1.625"	4.600"

### HEAD PARTS

Dart has everything you need to assemble a cylinder head: Titanium or Stainless Steel valves, springs, locks, retainers, seals, studs, and guide plates.

See page 115.

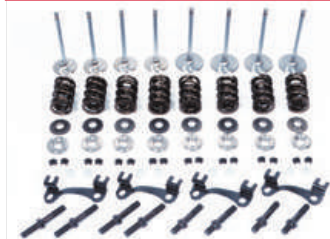





# 18° 330/383cc BIG BLOCK CHEVY CAST ALUMINUM CYLINDER HEADS

### QUICK INFO >>>

Maximum competition. High torque, high compression - low dome. 8,000+ RPM, 500+ cubic inches.

Race Series big block 18° oval port heads bridge the gap between conventional heads and Dart's Big Chief heads.

Utilizing Pro Stock style oval intake ports with 330cc or 383cc runners in a conventional asymmetrical port design, and featuring an 18° rolled valve angle with redesigned shallow combustion chambers, this design is ideal for drag racing, marine applications and dirt modified classes permitting big blocks.

Heads are sold individually.

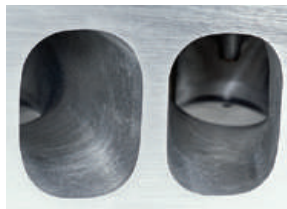
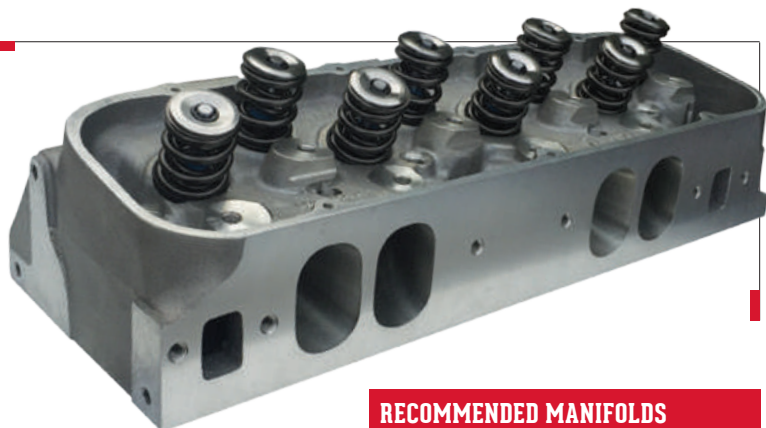

Head part kits - see pages 115.

Uses +.350" long intake valves.

Must use shaft mount rockers.

Requires special pistons.

### RACE SERIES 18° 330cc - ALUMINUM

PART NO.	CONFIGURATION	CNC PORTING	PORT VOL.	VALVES	SPRINGS	CYL. BORE.
16876040	Bare Head	Full Port	330cc	2.250"/1.840"		4.500"
16876146	Assembly	Full Port	330cc	2.250"/1.840"	1.625"D	4.500"
16877040	Bare Head	Full Port	330cc	2.250"/1.840"		4.600"
16877146	Assembly	Full Port	330cc	2.250"/1.840"	1.625"D	4.600"

### RACE SERIES 18° 383cc - ALUMINUM

PART NO.	CONFIGURATION	CNC PORTING	PORT VOL.	VALVES	SPRINGS	CYL BORE.
16874050	Bare Head	Full Port	383cc	2.350"/1.840"		4.500"
16874156	Assembly	Full Port	383cc	2.350"/1.840"	1.625"D	4.500"
16875050	Bare Head	Full Port	383cc	2.350"/1.840"		4.600"
16875156	Assembly	Full Port	383cc	2.350"/1.840"	1.625"D	4.600"



Dart Aluminum valve covers feature machined gasket surfaces to prevent messy oil leaks. Our new inverted flange valve covers provide extra room for long ratio rockers and oversized springs. See page 94.

### RECOMMENDED MANIFOLDS

#### FOR 9.800" DECK BLOCKS

- 41214100 Single Plane 4150
- 41214100 Single Plane 4500

#### FOR 10.200" DECK BLOCKS\*

- 41215100 Single Plane 4150
- 41215100 Single Plane 4500

\*Requires spacer plate kit.

- 62210007 330cc Intake Ports
- 62210009 383cc Intake Ports

### RACE SERIES 18° 330/383cc SPECS

- Material: RMR Cast Aluminum Alloy
- Valve Angle: 18°
- Intake Port Volume: 330/383cc
- Intake Valve: 2.250"/2.350"
- Exhaust Valve: 1.840"
- Chamber Volume: 102cc
- Intake Port Shape: Oval
- Exhaust Port Location: .400" raised

### 330cc FLOW DATA @ 28" WATER

LIFT	INTAKE	EXHAUST
.200"	190	120
.300"	254	164
.400"	318	191
.500"	377	222
.600"	404	257
.700"	412	276
.800"	413	301

### 383cc FLOW DATA @ 28" WATER

LIFT	INTAKE	EXHAUST
.200"	162	136
.300"	236	177
.400"	314	216
.500"	376	254
.600"	420	289
.700"	444	316
.800"	450	330

BILLET  
HON  
SBF  
BBC  
LS  
SBC  
ACCESS  
MANIFOLDS  
HEADS  
BLOCKS  
TOP END KITS  
SHORT BLOCKS



# 18° & 14° BIG BLOCK CHEVY 424cc CAST ALUMINUM CYLINDER HEADS

## QUICK INFO >>>

Maximum Top Sportsman, Top Dragster, Pro Mod and Pro Street competition. Excellent with alcohol and nitrous, over 7,000 RPM, over 500 cubic inches.

The original Dart Big Chief put the spread port design on the map, winning three NHRA Pro Stock championships before being banned from the class.

We have applied the PRO1 design concept to the Big Chief in order to help make spread port technology more affordable for Sportsman racers. High flowing cast ports combined with CNC machined chambers and bowls deliver awesome power.

Big Chief PRO1 18° and 14° head assemblies include hardened seats and stainless valves. Copper seats and Titanium valves are optional.

**Heads are sold individually.**



### BIG CHIEF PRO1 18° 424cc - ALUMINUM

PART NO.	CONFIGURATION	CNC PORTING	PORT VOL.	VALVES	SPRINGS	CYL. BORE
18474030	Bare Head	Chambers Only	424cc	2.400"/1.900"		4.500"
18474136	Assembly	Chambers Only	424cc	2.400"/1.900"	1.625"D	4.500"
18475030	Bare Head	Chambers Only	424cc	2.400"/1.900"		4.600"
18475136	Assembly	Chambers Only	424cc	2.400"/1.900"	1.625"D	4.600"

### BIG CHIEF PRO1 14° 424cc - ALUMINUM

PART NO.	CONFIGURATION	CNC PORTING	PORT VOL.	VALVES	SPRINGS	CYL. BORE
18464030	Bare Head	Chambers Only	424cc	2.400"/1.900"		4.500"
18464136	Assembly	Chambers Only	424cc	2.400"/1.900"	1.625"D	4.500"
18465030	Bare Head	Chambers Only	424cc	2.400"/1.900"		4.600"
18465136	Assembly	Chambers Only	424cc	2.400"/1.900"	1.625"D	4.600"

### BIG CHIEF PRO1 18° & 14° SPECS

Material:	RMR Cast Aluminum Alloy
Valve Angle:	18° & 14°
Intake Port Volume:	424cc
Intake Valve:	2.400"
Exhaust Valve:	1.900"
CNC Chamber Volume:	95cc w/Ti 100cc w/SS
Intake Port Shape:	Rectangle
Port Location:	Spread port

### FLOW DATA @ 28" WATER

LIFT	INTAKE	EXHAUST
.200"	158	138
.300"	222	185
.400"	284	229
.500"	345	267
.600"	390	293
.700"	420	302
.800"	431	305
.900"	437	309



**18°**  
424cc  
**CNC**

**14°**  
440cc  
**CNC**

# BIG BLOCK CHEVY CAST ALUMINUM CYLINDER HEADS

### QUICK INFO >>>

Maximum Top Sportsman, Top Dragster, Pro Mod and Pro Street competition. Excellent with alcohol and nitrous, over 7,000 RPM, over 500 cubic inches.

Big Chief heads have dominated in Sportsman through Pro Stock classes since their introduction, and we have continued to improve the design with the latest Pro Stock technology.

With our sophisticated CNC machining programs, we can tailor a pair of Big Chief 18° or 14° heads to fit your exact engine combination.

Big Chief PRO1 18° and 14° head assemblies include hardened seats and stainless valves. Copper seats and Titanium valves are optional.

**Heads are sold individually.**



Head part kits - see pages 115.

### BIG CHIEF 18° 424cc CNC - ALUMINUM

PART NO.	CONFIGURATION	CNC PORTING	PRG#	PORT VOL.	VALVES	SPRINGS	CYL. BORE
18000000	Bare Head	Rect.	381	N/A	N/A	N/A	N/A
18000000S	Solid Bare	Rect.	381	N/A	N/A	N/A	N/A
18074030	Bare Head	Rect.	381	424cc	2.400"/1.900"	Bare	4.500"
18074136	Full Port Assembly	Rect.	381	424cc	2.400"/1.900"	1.625"D	4.500"
18075030	Bare Head	Rect.	381	424cc	2.400"/1.900"	Bare	4.600"
18075136	Full Port Assembly	Rect.	381	424cc	2.400"/1.900"	1.625"D	4.600"

### BIG CHIEF 14° 440cc CNC - ALUMINUM

PART NO.	CONFIGURATION	CNC PORTING	PRG#	PORT VOL.	VALVES	SPRINGS	CYL. BORE
18100000	Bare Head	Rect.	3815	N/A	N/A	N/A	N/A
18100000S	Solid Bare	Rect.	3815	N/A	N/A	N/A	N/A
18174030	Bare Head	Rect.	3815	440cc	2.400"/1.900"	Bare	4.500"
18174136	Full Port Assembly	Rect.	3815	440cc	2.400"/1.900"	1.625"D	4.500"
18175030	Bare Head	Rect.	3815	440cc	2.400"/1.900"	Bare	4.600"
18175136	Full Port Assembly	Rect.	3815	440cc	2.400"/1.900"	1.625"D	4.600"

### BIG CHIEF 18° & 14° CNC SPECS

Material:	RMR Cast Aluminum Alloy
Valve Angle:	18°/14°
Intake Port Volume:	424/440cc CNC
Intake Valve:	2.400"
Exhaust Valve:	1.900"
Chamber Volume:	87cc
Intake Port Shape:	Rectangle
Port Location:	Spread port

### FLOW DATA @ 28" WATER

LIFT	18°/2.400" INTAKE	14°/2.400" INTAKE	1.900" EXHAUST
.200"	158	154	158
.300"	233	233	217
.400"	296	296	264
.500"	359	357	316
.600"	403	410	326
.700"	433	438	329
.800"	452	454	337
.900"	460	463	340

BILLET

HON

SBF

BBC

LS

SBC

ACCESS

MANIFOLDS

HEADS

BLOCKS

TOP END KITS

SHORT BLOCKS



**14°  
433cc  
CNC  
OVAL PORT**

# BIG BLOCK CHEVY CAST ALUMINUM CYLINDER HEADS

### QUICK INFO >>>

Maximum Top Sportsman, Top Dragster, Pro Mod and Pro Street competition. Excellent with alcohol and nitrous, over 7,000 RPM, over 500 cubic inches.

An updated Dart Big Chief 385 program incorporates a 2.500" intake valve for a dramatic increase in air flow.

Big Chief heads have dominated in Sportsman classes since their introduction, and we have continued to improve the design with the latest Pro Stock technology.

With our sophisticated CNC machining programs, we can tailor a pair of Big Chief 14° CNC heads to fit your exact engine combination.

Copper seats are standard and assemblies come with Titanium valves.

**Heads are sold individually.**



### BIG CHIEF 14° 433cc CNC SPECS

Material:	RMR Cast Aluminum Alloy
Valve Angle:	14°
Intake Port Volume:	433cc CNC
Intake Valve:	2.470"/2.500"
Exhaust Valve:	1.800"/1.850"
Chamber Volume:	86cc
Intake Port Shape:	Oval
Port Location:	Spread port

### FLOW DATA @ 28" WATER

LIFT	2.470" INTAKE	2.500" INTAKE	1.800" EXHAUST
.200"	164	169	129
.300"	254	251	182
.400"	333	330	218
.500"	398	395	251
.600"	446	447	288
.700"	482	499	316
.800"	493	523	338
.900"	495	525	349

### BIG CHIEF 14° 433cc CNC - ALUMINUM [Oval Port Heads]

PART NO.	CONFIGURATION	CNC PORTING	PRG#	PORT VOL.	VALVES	SPRINGS	CYL. BORE
18200000	Bare Head	No Porting	384				
18275070	Bare Head	Full Port	384	433cc	2.470"/1.800"		4.600"
18275179	Assembly	Full Port	384	433cc	2.470"/1.800"	1.650"T	4.600"
18300000	Bare Head	No Porting	385				
18375080	Bare Head	Full Port	385	433cc	2.500"/1.800"		4.600"
18375189	Assembly	Full Port	385	433cc	2.500"/1.800"	1.650"T	4.600"



**11°  
555cc  
CNC  
OVAL PORT**

# BIG BLOCK CHEVY CAST ALUMINUM CYLINDER HEADS

### QUICK INFO >>>

Maximum Top Sportsman, Top Dragster, Pro Mod and Pro Street competition. Excellent with alcohol and nitrous, over 7,000 RPM, over 500 cubic inches.

The latest Big Chief evolution with an 11° valve angle, this head features a multitude of revisions: relocated valve centers, relocated port cores, and a redesigned valve train for increased power and reliability.

With our sophisticated CNC machining programs, we can tailor a pair of Big Chief II heads to fit your exact engine combination.

Copper seats are standard and assemblies come with Titanium valves. Standard 2.500"/1.850" intake/exhaust valves.

*Heads are sold individually.*

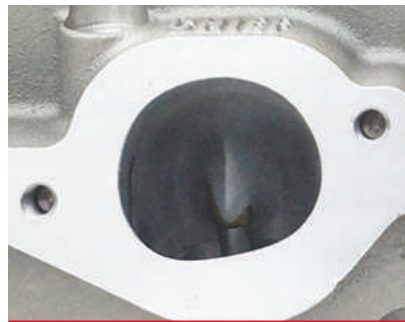
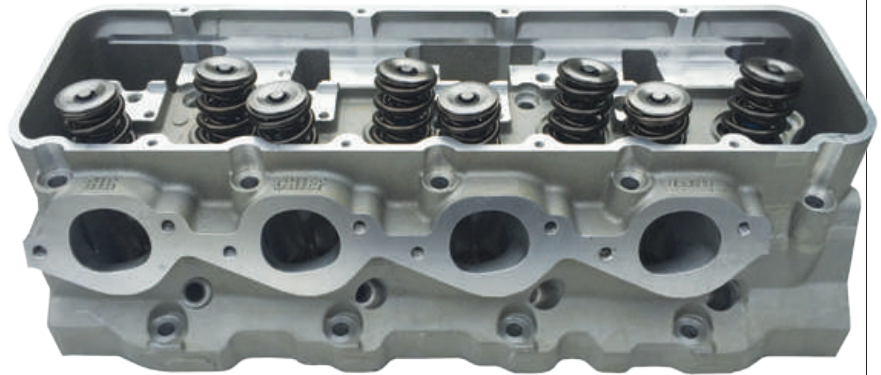

### RECOMMENDED MANIFOLD

See page 93

43144000  
Box Ram

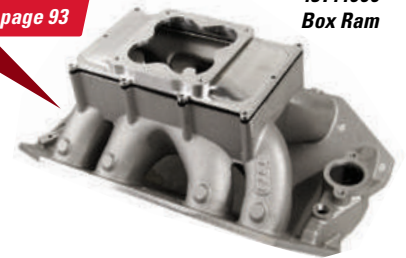

### BIG CHIEF II 11° 555cc CNC SPECS

Material:	RMR Cast Aluminum Alloy
Valve Angle:	11°
Intake Port Volume:	555cc CNC
Intake Valve:	2.500"
Exhaust Valve:	1.850"
Chamber Volume:	56-90cc
Intake Port Shape:	Oval
Port Location:	Spread port

### FLOW DATA w/ 2.500-1.850 valves

LIFT	INTAKE	EXHAUST
.200"	168	136
.300"	262	186
.400"	338	232
.500"	399	279
.600"	456	321
.700"	501	348
.800"	521	357
.900"	522	363
1.000"	534	364

### BIG CHIEF II 11° 555cc CNC - ALUMINUM [Oval Port Heads]

PART NO.	CONFIGURATION	CNC PORTING	PORT VOL.	VALVES	SPRINGS	CYL. BORE
18500000	Bare Head	No Porting				
18575070	Bare Head	Full Port	555cc	2.500"/1.850"		4.600"
18575179	Assembly	Full Port	555cc	2.500"/1.850"	1.650"T	4.600"

BILLET

HON

SBF

BBC

LS

SBC

ACCESS

MANIFOLDS

HEADS

BLOCKS

TOP END KITS

SHORT BLOCKS



**14°**  
**505cc**  
**5.000"**  
**BORE SPACE**

## BIG BLOCK CHEVY CAST ALUMINUM CYLINDER HEADS

### QUICK INFO >>>

For 5.000" bore space engines. Maximum Top Sportsman, Top Dragster, Pro Mod and Pro Street competition. Excellent with alcohol and nitrous, over 7,000 RPM

The original Dart Big Chief put the spread port design on the map, winning three NHRA Pro Stock championships before being banned from the class.

Our 14° Big Chief's have dominated in Sportsman classes since their introduction, and we have continued to improve the design with the latest Pro Stock technology now available in 5.000" bore centers.

With our sophisticated CNC machining programs, we can tailor a pair of Big Chief heads to fit your exact engine combination.

**Heads are sold individually.**

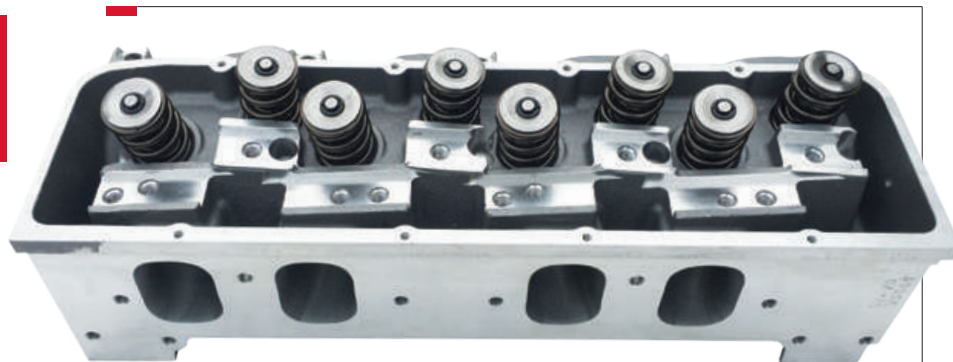

### BIG CHIEF 14° 505cc [5.000"] SPECS

Material:	RMR Cast Aluminum Alloy
Valve Angle:	14°
Intake Port Volume:	505cc
Intake Valve:	2.575"
Exhaust Valve:	1.900"
Chamber Volume:	76cc
Intake Port Shape:	Oval
Port Location:	Spread port

### BIG CHIEF 14° 505cc - ALUMINUM [5.000" Bore Space]

PART NO.	CONFIGURATION	CNC PORTING	PORT VOL.	VALVES	SPRINGS	CYL. BORE
18777060	Bare Head	Full Port	505cc	2.575"/1.900"		4.750"
18777169	Assembly	Full Port	505cc	2.575"/1.900"	1.650"T	4.750"

### FLOW DATA @ 28" WATER

LIFT	INTAKE	EXHAUST
.200"	163	152
.300"	260	203
.400"	344	251
.500"	413	302
.600"	468	334
.700"	512	356
.800"	540	366
.900"	551	371
1.000"	560	374

### DART ONE-PIECE ROCKER BAR

For "No-Z" rocker arms  
PN 61400001

Use T&D rocker arms  
T&D PN 16-1578

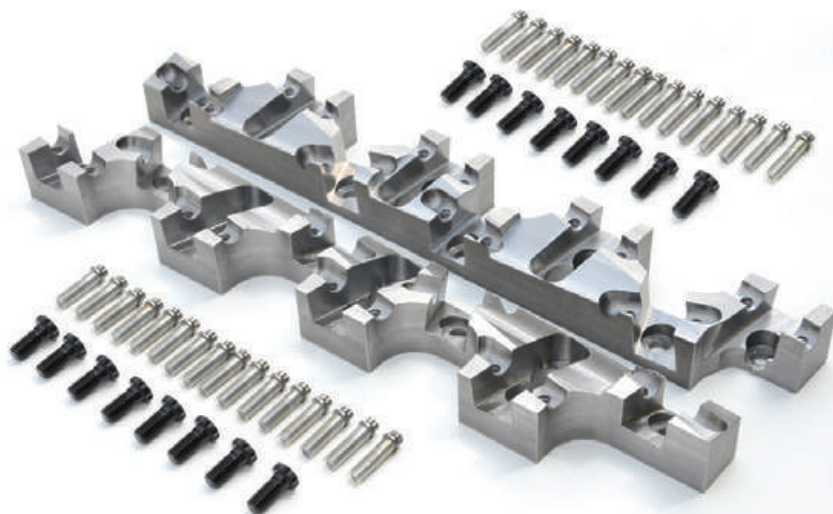

# BIG BLOCK CHEVY INTAKE MANIFOLDS

An engine's cylinder heads and intake manifold must work together as an integrated system to produce maximum performance. The intake charge should make a seamless transition from the manifold runners to the cylinder head ports. Dart has accomplished this in every intake manifold we make.

## SINGLE PLANE

PART NO	DESCRIPTION	PORT STYLE	DECK	CARB
41114000	BBC Manifold	Rectangle	9.800	4150
41115000	BBC Manifold	Rectangle	10.200	4150
41124000	BBC Manifold	Rectangle	9.800	4500
41125000	BBC Manifold	Rectangle	10.200	4500
41214000	BBC Manifold	Oval	9.800	4150
41215000	BBC Manifold	Oval	10.200	4150
41224000	BBC Manifold	Oval	9.800	4500
41225000	BBC Manifold	Oval	10.200	4500

41114000  
BBC



## TUNNEL RAM

PART NO	DESCRIPTION	PORT STYLE	DECK
41134000	BBC Manifold Tunnel Ram*	Rectangle	9.800"
41135000	BBC Manifold Tunnel Ram*	Rectangle	10.200"

\*Includes top plate of choice

62420010	Tunnel Ram Top Plate Blank
62420020	Tunnel Ram Top Plate 2x4150 Inline
62420030	Tunnel Ram Top Plate 2x4150 Side
62420040	Tunnel Ram Top Plate 2x4500
62420050	Tunnel Ram Top Plate Enderle

41134000  
Tunnel Ram



## BIG CHIEF SINGLE PLANE [Rectangle Port]

PART NO.	DESCRIPTION	PORT STYLE	DECK	CARB
43124000	Big Chief Manifold	Rectangle	9.800"	4500
43124002	Big Chief Manifold SM Comp	Rectangle	9.800"	4500
43125000	Big Chief Manifold	Rectangle	10.200"	4500
43125002	Big Chief Manifold SM Comp	Rectangle	10.200"	4500

43124000  
Single Plane



## BIG CHIEF SINGLE PLANE [Oval Port]

PART NO.	DESCRIPTION	PORT STYLE	DECK	CARB
43224000	Big Chief Manifold	Oval (requires port match)	9.800"	4500
43224002	Big Chief Manifold	Oval SM Comp	9.800"	4500
43225000	Big Chief Manifold	Oval (requires port match)	10.200"	4500
43225002	Big Chief Manifold	Oval SM Comp	10.200"	4500

## BIG CHIEF BOX RAM SINGLE PLANE [Oval Port]

PART NO.	DESCRIPTION	PORT STYLE	DECK	CARB
43144000	Box Ram Big Chief	Oval	9.800"	4500
43145000	Box Ram Big Chief	Oval	10.200"	4500
43144100	Box Ram Big Chief	Rectangle	9.800"	4500
43145100	Box Ram Big Chief	Rectangle	10.200"	4500
62430010	Box Ram Pent Roof Top Plate			

\*Includes flat single 4500 top plate

43144000  
Box Ram



## GEN 7 8.1 LITER DUAL PLANE [Cathedral Port]

PART NO.	DESCRIPTION	PORT STYLE	DECK	CARB
41616010	8.1 L Dual Plane	Cathedral	10.236"	4150

41616010  
8.1L Dual Plane



BILLET

HON

SBF

BBC

LS

SBC

ACCESS

MANIFOLDS

HEADS

BLOCKS

TOP END KITS

SHORT BLOCKS

# BIG BLOCK CHEVY ACCESSORIES

## VALVE COVERS

Our extra tall valve covers are designed to clear racing valve trains, stud girdles, and to specifically fit Dart cylinder heads.

Chrome plated stamped steel valve covers have an embossed Dart logo, breather hole and baffle.

Cast Aluminum valve covers feature machined gasket surfaces to prevent messy oil leaks. The raised Dart logo stands out with a contrasting machined finish. Our new inverted flange valve covers provide extra room for long ratio rockers and oversized springs.

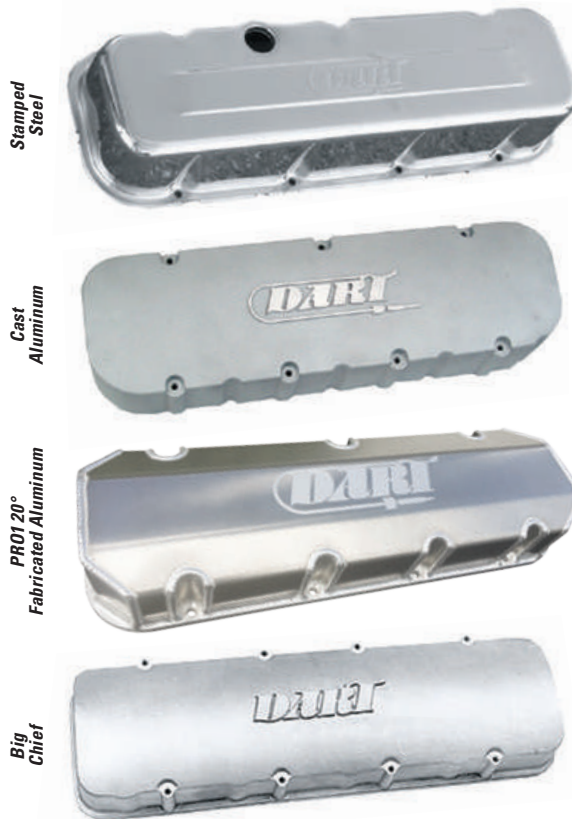

## VALVE COVERS

PART NO.	DESCRIPTION	FITS
68000060	Stamped Steel Valve Cover Set	Dart BBC
68000040	Cast Aluminum Valve Cover Set	Dart BBC
68000045	Fabricated Aluminum Valve Cover Set	PRO1 20°
68000030	Cast Aluminum Valve Cover Set	Dart Big Chief

*Note: All valve covers include gaskets and fastners (except Big Chief).*

## VALVE TRAIN STABILIZERS

Valve train stabilizers, also known as "stud girdles" improve the performance and reliability of engines equipped with stud mounted rocker arms. Extra long adjusting nuts are tightly clamped between rigid Aluminum bars that prevent stud deflection under high loads. The valve motion more closely follows the cam profile, producing more power and reducing breakage. Unlike "universal" girdles, these valve train stabilizers are designed to fit the specific valve locations, valve angles, and valve lengths in Dart cylinder heads. Kits include hardened poly-lock adjusting nuts.

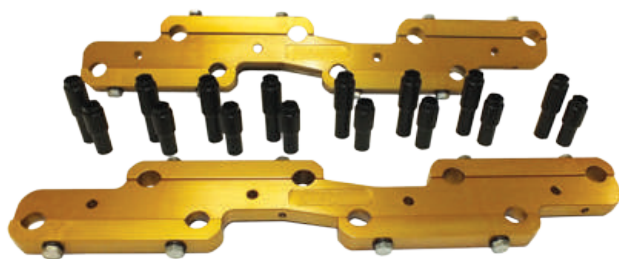

## VALVE TRAIN STABILIZERS

PART NO.	DESCRIPTION	FITS
64110001	Valve Train Stabilizer	Dart BBC

## HEAD PARTS KITS

Dart parts kits include everything you need to assemble a cylinder head: Stainless Steel valves, springs, locks, retainers, seals, studs, and guide plates. These kits contain the same high quality components we use in our cylinder head assemblies. Each kit does one cylinder head.

## BIG BLOCK HEAD PARTS KITS (INCLUDES STEEL RETAINERS)

PART NO.	INT.	EXH.	SPRING	PART NO.	INT.	EXH.	SPRING
28000011	2.250"	1.880"	1.550" single	28000042	2.300"	1.900"	1.550" double
28000012	2.250"	1.880"	1.550" double	28000043	2.300"	1.900"	1.625" double
28000013	2.250"	1.880"	1.625" double	28000063	2.350"	1.850"	1.625" double
28000022	2.250"	1.900"	1.550" double	28000073	2.350"	1.880"	1.625" double
28000023	2.250"	1.900"	1.625" double	28000093	2.400"	1.800"	1.625" double
28000033	2.300"	1.880"	1.625" double	28000094	2.400"	1.800"	1.650" triple



## BIG-BLOCK ADJUSTABLE GUIDE PLATES

PART NO.	DESCRIPTION
27001230	Each
27001230-4	Set of 4 (does one head)

BILLET

HON

SBF

BBC

LS

SBC

ACCESS

MANIFOLDS

HEADS

BLOCKS

TOP END KITS

SHORT BLOCKS





# SMALL BLOCK FORD SHORT BLOCKS

### QUICK INFO >>>

Professionally built short blocks with all brand new premium components. Street performance, Sportsman racing.

## 347, 363 & 427 CUBIC INCHES

Simplify engine building and save time with pre-engineered, dyno tested short block combinations from Dart's Special High Performance group.

These quality component packages are designed to allow you to build powerful and durable engines at a very affordable cost.



Top off your Dart short block with one of our performance matched top end kits for a great performing engine at an affordable price.

### 347 CUBIC INCH SHORT BLOCK

- Externally Balanced 28oz
- Special High Performance 8.200" Dart Block
- 4.030" Bore x 3.400" Stroke
- Plate Honed Cylinders
- Cast Steel Crankshaft
- Forged 4340 I-Beam Rods w/ 3/8" Cap Screws
- Forged Flat Top Pistons w/ Full Floating Pin
- Hastings Moly Rings
- Clevite Bearings
- Coated Cam Bearings

**Upgrades Available: Forged 4340 Crank, H-Beam Rods w/ 7/16" ARP 2000 Bolts & Forged Pistons. Internal Balance.**

**Flat Top:**  
CR 10.0:1 w/58cc chamber & .041" gasket.

**Flat Top:**  
CR 9.5:1 w/62cc chamber & .041" gasket.

### 363 CUBIC INCH SHORT BLOCK

- Externally Balanced 28oz
- Special High Performance 8.200" Dart Block
- 4.125" Bore x 3.400" Stroke
- Plate Honed Cylinders
- Cast Steel Crankshaft
- Forged 4340 I-Beam Rods w/ 3/8" Cap Screws
- Forged Flat Top Pistons w/ Full Floating Pin
- Hastings Moly Rings
- Clevite Bearings
- Coated Cam Bearings

**Upgrades Available: Forged 4340 Crank, H-Beam Rods w/ 7/16" ARP 2000 Bolts & Forged Pistons. Internal Balance.**

**Flat Top:**  
CR 10.2:1 w/58cc chamber & .041" gasket.

**Flat Top:**  
CR 9.7:1 w/62cc chamber & .041" gasket.

### 427 CUBIC INCH SHORT BLOCK

- Internally Balanced
- Special High Performance 9.500" Dart Block
- 4.125" Bore x 4.000" Stroke
- Plate Honed Cylinders
- Forged 4340 Steel Crankshaft
- Forged 4340 H-Beam Rods w/ 7/16" ARP 2000 Bolts
- Forged Dished Pistons w/ Full Floating Pin
- Hastings Moly Rings
- Clevite Bearings
- Coated Cam Bearings

**Options Available: Flat Top Pistons**

**-26cc Dish:**  
CR 10.2:1 w/58cc chamber & .041" gasket.

**-26cc Dish:**  
CR 9.8:1 w/62cc chamber & .041" gasket.

**\*Flat top options will raise CR by 2.5 (58cc) - 2.2 (62cc)**

### SHP FORD SHORT BLOCKS

PART NO.	DESCRIPTION	CRANK	PISTONS	RODS	BORE	STROKE	BALANCE
03213472	347 SHP	Cast	Forged	I-Beam	4.030"	3.400"	28oz External
	Forged Ford	Forged	Forged	H-Beam	4.030"	3.400"	Internal
03243632	363 SHP	Cast	Forged	I-Beam	4.125"	3.400"	28oz External
	Forged Ford	Forged	Forged	H-Beam	4.125"	3.400"	Internal
03224272	427 SHP	Forged	Forged	H-Beam	4.125"	4.000"	Internal

BILLET

HON

SBF

BBC

LS

SBC

ACCESS

MANIFOLDS

HEADS

BLOCKS

TOP END KITS

SHORT BLOCKS

# SMALL BLOCK FORD TOP END KITS - CAST IRON OR CAST ALUMINUM

## QUICK INFO >>>

Performance matched top end kits from Dart are the perfect way to finish off your Dart short block or upgrade your existing engine.

Dart top end kits for small block Ford engines offer a full compliment of performance matched parts that make building your engine simple and easy. These kits were designed to deliver excellent performance at a great price!

## DART TOP END KITS INCLUDE

- Fully assembled cylinder heads.
- Aluminum valve covers.
- Intake manifold, selected to compliment the cylinder heads.
- Intake gaskets, head gaskets, and exhaust gaskets.
- Spark plugs.
- Head bolts.



Available with 7/16" head bolts for stock blocks or 1/2" head bolts for Dart blocks.

See pages 102-104 for more information on Iron Eagle cylinder heads used in these kits.

## SBF TOP END KITS WITH IRON EAGLE CYLINDER HEADS

PART NO.	HEADS	PORTS	CHAMBER	FITS BLOCK	VALVES	SPRINGS	MANIFOLD
01150111	Iron	180cc	62cc	302 - 8.200"	2.020"/1.600"	1.250"	Dual Plane
01150112	Iron	180cc	62cc	302 - 8.200"	2.020"/1.600"	1.437"	Dual Plane
01151111	Iron	180cc	62cc	351 - 9.500"	2.020"/1.600"	1.250"	Dual Plane
01151112	Iron	180cc	62cc	351 - 9.500"	2.020"/1.600"	1.437"	Dual Plane
01150122	Iron	200cc	58cc	302 - 8.200"	2.020"/1.600"	1.437"	Dual Plane
01150132	Iron	200cc	62cc	302 - 8.200"	2.020"/1.600"	1.437"	Dual Plane
01151122	Iron	200cc	58cc	351 - 9.500"	2.020"/1.600"	1.437"	Dual Plane
01151132	Iron	200cc	62cc	351 - 9.500"	2.020"/1.600"	1.437"	Dual Plane

## SBF TOP END KITS WITH PRO1 CYLINDER HEADS

PART NO.	HEADS	PORTS	CHAMBER	FITS BLOCK	VALVES	SPRINGS	MANIFOLD
01250101	Alum	170cc	62cc	302 - 8.200"	1.940"/1.600"	1.250"	Dual Plane
01250102	Alum	170cc	62cc	302 - 8.200"	1.940"/1.600"	1.437"	Dual Plane
01251101	Alum	170cc	62cc	351 - 9.500"	1.940"/1.600"	1.250"	Dual Plane
01251102	Alum	170cc	62cc	351 - 9.500"	1.940"/1.600"	1.437"	Dual Plane
01251122	Alum	195cc	62cc	351 - 9.500"	2.020"/1.600"	1.437"	Dual Plane
01251123	Alum	195cc	62cc	351 - 9.500"	2.020"/1.600"	1.550"	Dual Plane
01250023	Alum	195cc	62cc	302 - 8.200"	2.020"/1.600"	1.550"	Single Plane

See pages 105-108 for more information on PRO1 cylinder heads used in these kits.



# SMALL BLOCK FORD CAST IRON ENGINE BLOCKS

## QUICK INFO >>>

Designed for high performance and heavy duty applications, the SHP block is the ideal starting point for hot rodders, drag racers, circle track competitors, off-roaders, and high performance marine enthusiasts.

The SHP Ford block is tailored to the most popular performance and racing applications, with an 8.200" (302), 9.200" (351c) or 9.500" (351w) deck height and a choice of 4.000" or 4.125" siamesed cylinder bores which can safely be bored to 4.185". Steel main caps are splayed 4-bolt on the center three and 2-bolt on #1 and #5, and utilize 1/2" bolts. The valley is machined to accept factory roller lifter guides and retainer (spider).



## FEATURES

- Priority main oiling system directs oil to main bearings first for more dependable lubrication.
- No provision for oil restrictors.
- Available with an 8.200" (302), 9.200" (351c) or 9.500" (351w).
- Provisions for OE stock roller lifters, dog bones & spider.
- Siamese bores 4.000" or 4.125" (unfinished) with extra thick cylinder walls.
- Extended cylinder barrels for improved piston support.
- Extra thick decks ensure reliable head gasket seal.
- Blind head bolt holes don't go through to water jacket.
- Steel 4-bolt main caps on #2, 3 and 4 with splayed outer bolts. 2-bolt main caps on #1 and 5.
- Can use most stock components and accessories.
- Scalloped water jackets increase coolant flow around cylinder barrels to prevent detonation, extend engine life and produce consistent cylinder temperatures.
- Parts kit sold separately (PN 32000015 - see page 115).



## SPECIAL HIGH PERFORMANCE - IRON

PART NO.	DESCRIPTION	CAPS	MAIN SIZE	DECK	BORE
31364175	302 SHP	Steel	302	8.200"	4.000"
31364275	302 SHP	Steel	302	8.200"	4.125"
31365195	351 SHP	Steel	351C	9.200"	4.000"
31365295	351 SHP	Steel	351C	9.200"	4.125"
31365135	351 SHP	Steel	351C	9.500"	4.000"
31365235	351 SHP	Steel	351C	9.500"	4.125"

## SHP SPECS

Material:	220 BHN Cast Iron
Deck Heights:	8.200", 9.200" and 9.500"
Cylinder Bores:	4.000" or 4.125" 4.185" (max)
Main Bearings:	302 or 351C
Main Caps:	Steel 4-bolt #2, 3 & 4 2-bolt #1 & 5
Lifter Provision:	OE roller or aftermarket
Restrictor Provision:	None
Freeze Plugs:	Press fit
Weight:	178-210 lbs.

BILLET

HON

SBF

BBC

LS

SBC

ACCESS

MANIFOLDS

HEADS

BLOCKS

TOP END KITS

SHORT BLOCKS



# SMALL BLOCK FORD CAST IRON ENGINE BLOCKS

## QUICK INFO >>>

Designed for high performance and heavy duty applications, the Sportsman block is ideal for drag racers, circle track competitors, off-roaders, and high performance marine enthusiasts.

Dart's Iron Eagle Sportsman block is the affordable alternative for Sportsman racers and serious street performance.

The Sportsman block shares most of the Iron Eagle's best features, but saves you money. Dart blocks are cast from premium high strength Iron with extra thick cylinder walls and decks. Main bearing caps are 4-bolt on the center three and 2-bolt on the ends to simplify oil pan fitment.

## FEATURES

- Siamesed cylinders: Standard 4.000" or 4.125" cylinders can be safely bored to 4.185" diameter, extra thick walls prevent cracking and produce excellent ring seal.
- Extended cylinder barrels for improved piston support.
- Steel 4-bolt main bearing caps are standard. Three center caps have splayed outer bolts for maximum strength; rear cap uses standard one piece seal. Sportsman blocks use 4-bolt centers and 2-bolt end caps.
- Upgraded oiling system has been completely redesigned with a low restriction priority main oiling system with rear external oil pump feed.
- Scalloped water jackets increase coolant flow around cylinder barrels to prevent detonation, extend engine life and produce consistent cylinder temperatures.
- Stock components make Dart blocks a direct replacement for most production small blocks. Provisions for stock motor mounts, accessory drives, smog pumps, starter brackets, oil pans and pumps.
- Reinforced head bolt bosses are blind to prevent leaks and produce more accurate torque readings. Extra thick decks prevent head gasket leaks.
- Standard camshaft and camshaft drive can be used. Lifter valley of the Sportsman block has bosses for production hydraulic roller lifters.
- Parts kit sold separately (PN 32000003 - see page 115).

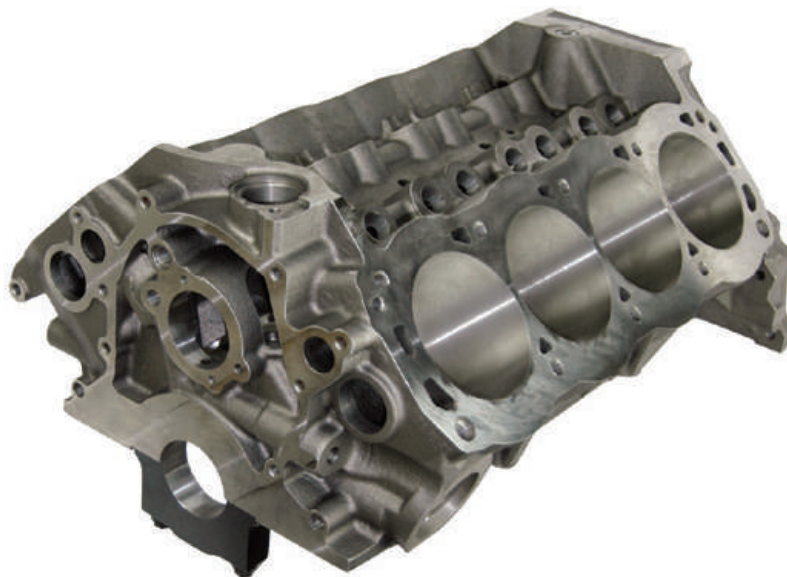

## SPORTSMAN - IRON

PART NO.	DESCRIPTION	CAPS	MAIN SIZE	DECK	BORE
31354175	302 Sportsman	Steel	302	8.200"	4.000"
31354275	302 Sportsman	Steel	302	8.200"	4.125"
31355135	351 Sportsman	Steel	351C	9.500"	4.000"
31355235	351 Sportsman	Steel	351C	9.500"	4.125"

## SPORTSMAN SPECS

Material:	220 BHN Cast Iron
Deck Height:	8.200" or 9.500"
Cylinder Bores:	4.000" or 4.125" 4.185" (max)
Main Bearings:	302 or 351C
Main Caps:	Steel 4-bolt #2,3 & 4 2-bolt #1 & 5
Lifter Provision:	OE roller or aftermarket
Restrictor Provision:	None
Freeze Plugs:	Press fit
Weight:	178-210 lbs.



# SMALL BLOCK FORD CAST IRON ENGINE BLOCKS

## QUICK INFO >>>

True race block which will work with most standard components. Provisions for wet or dry sump oiling systems. Great for power adders and maximum effort engines.

Dart's Iron blocks for Ford are designed to work with stock components, but are much more than a stock replacement.

Designed from the ground up for hard core racing, all the weaknesses of the factory castings have been addressed. Dart blocks are cast from premium high strength Iron with extra thick cylinder walls and decks. The main webs are beefed up and fitted with steel 4-bolt main caps.

## FEATURES

- Siamesed cylinders: Standard 4.000" or 4.125" cylinders can be safely bored to 4.185" diameter, extra thick walls prevent cracking and improve ring seal.
- Extended cylinder barrels for improved piston support.
- Four deck heights: 8.200" (302), 8.700" (stroker 302), 9.200" (351C) and 9.500" (351W) allow increased displacements up to 468 cubic inches.
- Steel 4-bolt main bearing caps are standard. Three center caps have splayed outer bolts for maximum strength.
- Two main bearing diameters: 302 (2.249") or 351C (2.749") allow choice of small or large journal crankshaft.
- Upgraded oiling system has been completely redesigned with a low restriction priority main oiling system with rear external oil pump feed.
- Reinforced head bolt bosses are blind tapped to prevent leaks and produce accurate torque readings. Extra thick decks prevent head gasket leaks.
- Parts kit included (PN 32000003 - see page 115).

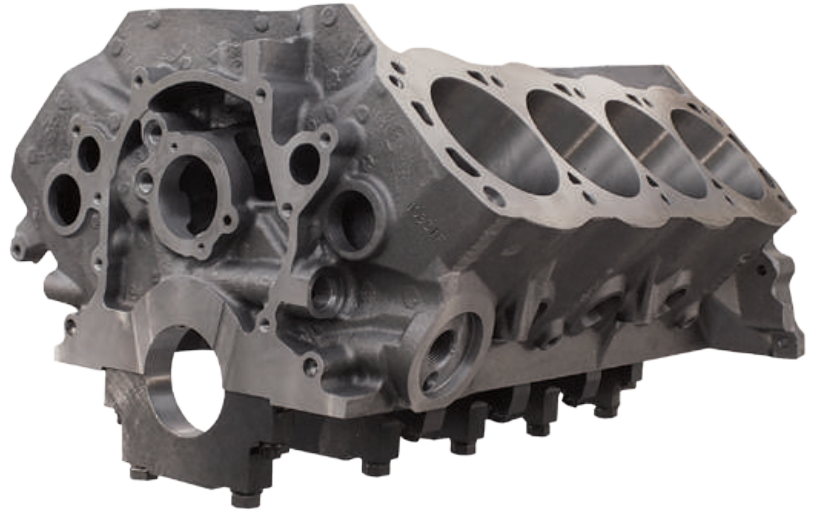

## IRON EAGLE

PART NO.	DESCRIPTION	CAPS	MAIN SIZE	DECK	BORE
31384175	302 Std. Deck	Steel	302	8.200"	4.000"
31384275	302 Std. Deck	Steel	302	8.200"	4.125"
31384185	302 Tall Deck	Steel	302	8.700"	4.000"
31384285	302 Tall Deck	Steel	302	8.700"	4.125"
31384195	351 W Short Deck	Steel	302	9.200"	4.000"
31384295	351 W Short Deck	Steel	302	9.200"	4.125"
31385195	351 W Short Deck	Steel	351C	9.200"	4.000"
31385295	351 W Short Deck	Steel	351C	9.200"	4.125"
31385135	351 Std. Deck	Steel	351C	9.500"	4.000"
31385235	351 Std. Deck	Steel	351C	9.500"	4.125"

## IRON EAGLE SPECS

Material: 220 BHN Cast Iron  
 Deck Heights: 8.200", 8.700", 9.200" and 9.500"  
 Cylinder Bores: 4.000" or 4.125" 4.185" (max)  
 Main Bearings: 302 or 351C  
 Main Caps: Steel 4-bolt  
 Lifter Provision: .875" tie bar  
 Restrictor Provision: Front & rear  
 Freeze Plugs: Press fit  
 Weight: 178-210 lbs.

BILLET

HON

SBF

BBC

LS

SBC

ACCESS

MANIFOLDS

HEADS

BLOCKS

TOP END KITS

SHORT BLOCKS

**PRO**

# SMALL BLOCK FORD CAST IRON ENGINE BLOCKS

## QUICK INFO >>>

The Dart Iron Eagle PRO is a true race block that is modified to accommodate 21st century power levels for most nitrous, blower or turbo applications.

## FEATURES

- Upgraded main bolts to main studs.
- Reduced .250" main oil feed holes.
- Reduced .090" cam to crank oil feed (Babbitt cam).
- Removed cam to crank oil feed (Roller cam).
- Removed oil filter location.
- Removed front -10AN oil feed.
- Removed rear lifter cross over.
- External dry sump or external wet sump only.
- Removed stock oil pump mounting boss.

## OPTIONAL FEATURES

- Machine for threaded freeze plugs.
- Removed distributor bore for coil on plug applications.
- Tie bar or keyed lifter bushings.



1/2" NPT Oil Feed / Removed Rear Crossover



Removed -10AN oil feed and oil filter mount

**IRON EAGLE PRO**

### #1 MAIN OIL FEED

**IRON EAGLE STANDARD**

## IRON EAGLE PRO

PART NO.	DESCRIPTION	CAPS	MAIN SIZE	DECK	BORE
31384176	302 Std. Deck	Steel	302	8.200"	4.000"
31384276	302 Std. Deck	Steel	302	8.200"	4.125"
31384186	302 Tall Deck	Steel	302	8.700"	4.000"
31384286	302 Tall Deck	Steel	302	8.700"	4.125"
31384196	351 W Short Deck	Steel	302	9.200"	4.000"
31384296	351 W Short Deck	Steel	302	9.200"	4.125"
31385196	351 W Short Deck	Steel	351C	9.200"	4.000"
31385296	351 W Short Deck	Steel	351C	9.200"	4.125"
31385136	351 Std. Deck	Steel	351C	9.500"	4.000"
31385236	351 Std. Deck	Steel	351C	9.500"	4.125"

## IRON EAGLE PRO SPECS

Material:	220 BHN Cast Iron
Deck Heights:	8.200", 8.700", 9.200" and 9.500"
Cylinder Bores:	4.000" or 4.125" 4.185" (max)
Main Bearings:	302 or 351C
Main Caps:	Steel 4-bolt
Lifter Provision:	.875" tie bar
Restrictor Provision:	Front Oil Crossover
Freeze Plugs:	Press fit or Screw-in
Weight:	178-210 lbs.



# SMALL BLOCK FORD CAST ALUMINUM ENGINE BLOCKS

## QUICK INFO >>>

The Dart Aluminum small block is light, strong, and affordable. With displacements up to 450 cubic inches, the Dart Aluminum block is ideal for sprint cars, modifies, late model stock cars, dragsters, and unlimited competition classes.

With pressed-in dry sleeves, upgraded oiling and steel 4-bolt main caps, Dart's Aluminum blocks have the features that Ford racers need to build powerful and reliable engines.

## FEATURES

- Premium alloy: Dart Aluminum blocks are cast from RMR cast Aluminum alloy for superior strength and integrity.
- Extended cylinder barrels for improved piston support.
- Four deck heights: 8.200" (302), 8.700" (stroker 302), 9.200" (351C) and 9.500" (351W) allow displacements up to 450 cubic inches.
- Siamesed cylinders: Standard 4.000" or 4.125" cylinders can be safely bored to 4.165" diameter. Ductile Iron sleeves and extra thick walls prevent cracking and produce excellent ring seal.
- Steel 4-bolt main bearing caps are standard. Three center caps have splayed outer bolts for maximum strength; rear cap uses standard one piece seal.
- Upgraded oiling system has been completely redesigned with a low restriction priority main oiling system with rear external oil pump feed.
- Dual crossovers allow oil flow to be metered with restrictors for roller lifter cams and/or roller rocker arms to reduce oil flow and windage.
- Reinforced head bolt bosses are blind tapped to prevent leaks and produce accurate torque readings. Extra thick decks prevent head gasket leaks.
- Parts kit included (PN 32000004 - see page 115).

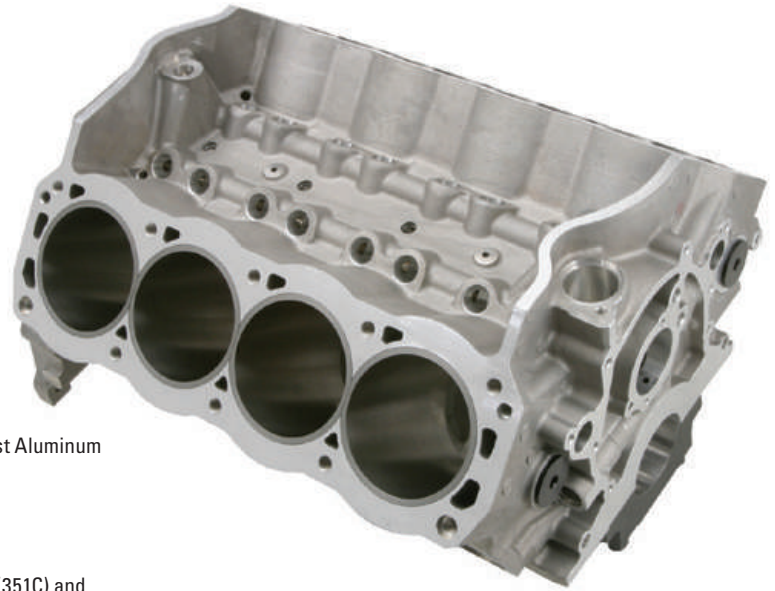

Dart blocks can be special ordered with a wide array of special machining options to suit your specific requirements.

## RACE SERIES - ALUMINUM

PART NO.	DESCRIPTION	CAPS	MAIN SIZE	DECK	BORE
31344175	302 Std. Deck	Steel	302	8.200"	4.000"
31344275	302 Std. Deck	Steel	302	8.200"	4.125"
31344185	302 Tall Deck	Steel	302	8.700"	4.000"
31344285	302 Tall Deck	Steel	302	8.700"	4.125"
31344195	351 W Short Deck	Steel	302	9.200"	4.000"
31344295	351 W Short Deck	Steel	302	9.200"	4.125"
31345195	351 W Short Deck	Steel	351C	9.200"	4.000"
31345295	351 W Short Deck	Steel	351C	9.200"	4.125"
31345135	351 Std. Deck	Steel	351C	9.500"	4.000"
31345235	351 Std. Deck	Steel	351C	9.500"	4.125"

## RACE SERIES SPECS

Material:	RMR Cast Aluminum Alloy
Deck Heights:	8.200", 8.700", 9.200" and 9.500"
Cylinder Bores:	4.000" or 4.125" 4.165" (max)
Main Bearings:	302 or 351C
Main Caps:	Steel 4-bolt
Lifter Provision:	.875" tie bar
Restrictor Provision:	Front & rear
Freeze Plugs:	Screw-in
Weight:	85-109 lbs.

BILLET

HON

SBF

BBC

LS

SBC

ACCESS

MANIFOLDS

HEADS

BLOCKS

TOP END KITS

SHORT BLOCKS



**20°  
180cc**

# SMALL BLOCK FORD CAST IRON CYLINDER HEADS

### QUICK INFO >>>

Excellent street, strip, oval track and truck or marine performance upgrade. Maximum torque and throttle response from idle to 6,000 RPM. Best for 302-351 cubic inch engines. Works with most standard components.

Dart Iron Eagle 20° 180cc heads are an affordable alternative to more expensive Aluminum heads. These 180cc heads out-perform many larger heads in a wide range of applications.

Long wearing Bronze valve guides, screw-in studs, multi-angle intake seats and hardened and radiused exhaust seats are standard. Best of all, our precision cast ports produce outstanding airflow without time consuming porting.

Assemblies include Stainless Steel valves, premium springs, locks, retainers, studs, guide plates and seals.

*Heads are sold individually.*

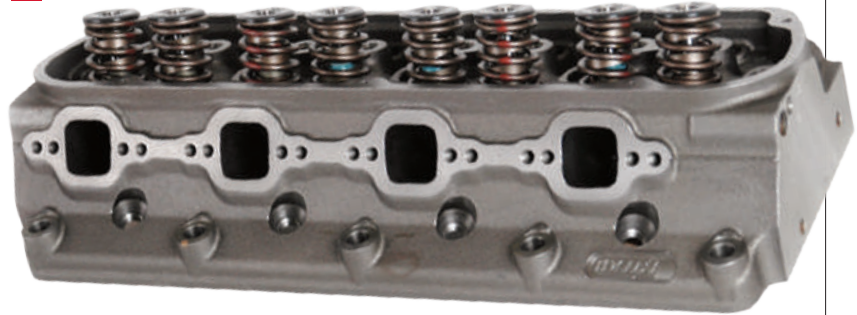

### IRON EAGLE 20° 180cc - IRON [w/ 1.940" Intake Valve]

#### 58cc COMBUSTION CHAMBERS

PART NO.	CONFIGURATION FOR USE	MAX. LIFT
13300080	Bare Head	
13301181	1.250" Single Springs for Hydraulic Flat Tappet Cam	.510"
13301182	1.437" Dual Springs for Hydraulic Roller or Solid Flat Tappet Cam	.650"

#### 62cc COMBUSTION CHAMBERS

PART NO.	CONFIGURATION FOR USE	MAX. LIFT
13310080	Bare Head	
13311181	1.250" Single Springs for Hydraulic Flat Tappet Cam	.520"
13311182	1.437" Dual Springs for Hydraulic Roller or Solid Flat Tappet Cam	.650"

### IRON EAGLE 20° 180cc - IRON [w/ 2.020" Intake Valve]

#### 58cc COMBUSTION CHAMBERS

PART NO.	CONFIGURATION FOR USE	MAX. LIFT
13300010	Bare Head	
13301111	1.250" Single Springs for Hydraulic Flat Tappet Cam	.510"
13301112	1.437" Dual Springs for Hydraulic Roller or Solid Flat Tappet Cam	.650"

#### 62cc COMBUSTION CHAMBERS

PART NO.	CONFIGURATION FOR USE	MAX. LIFT
13310010	Bare Head	
13311111	1.250" Single Springs for Hydraulic Flat Tappet Cam	.510"
13311112	1.437" Dual Springs for Hydraulic Roller or Solid Flat Tappet Cam	.650"

Head parts kit - see page 115.

Uses 3/8" screw-in rocker studs.  
7/16" upgrade available.

### IRON EAGLE 20° 180cc SPECS

Material:	220 BHN Cast Iron
Valve Angle:	20° (stock)
Intake Port Volume:	180cc
Intake Valve:	1.940" or 2.020"
Exhaust Valve:	1.600"
Chamber Volume:	58cc or 62cc

### FLOW DATA @ 28" WATER

LIFT	INTAKE	EXHAUST
.200"	125	112
.300"	178	139
.400"	226	152
.500"	247	159
.600"	256	161
.700"	260	163





**20°  
200cc**

# SMALL BLOCK FORD CAST IRON CYLINDER HEADS

### QUICK INFO >>>

*Serious street performance, mild bracket racing and oval track. Maximum torque and throttle response from idle to 6,800 RPM. Best for 347-427 cubic inch engines. Works with most standard components.*

Made from premium Cast Iron and precision machined on our digital CNC machining centers, Iron Eagle's are ready to go right out of the box. Intake runners feature streamlined valve guide bosses for improved airflow.

Standard valve angle and spacing is retained for bolt on compatibility. Manganese Bronze valve guides are used for long life, and hardened valve seats provide durability with unleaded fuels.

Assemblies include Stainless Steel valves, premium springs, locks, retainers, studs, guide plates and seals.

**Heads are sold individually.**



Head parts kit - see page 115.

Uses 3/8" screw-in rocker studs.  
7/16" upgrade available

Assemblies with 1.550" valve spring  
use +.100" long valves.

### IRON EAGLE 20° 200cc SPECS

Material:	220 BHN Cast Iron
Valve Angle:	20° (stock)
Intake Port Volume:	200cc
Intake Valve:	2.020"
Exhaust Valve:	1.600"
Chamber Volume:	58 or 62cc

### FLOW DATA @ 28" WATER

LIFT	INTAKE	EXHAUST
.200"	154	112
.300"	208	139
.400"	254	152
.500"	271	159
.600"	274	161
.700"	276	163

### IRON EAGLE 20° 200cc - IRON [w/ 2.020" Intake Valve]

#### 58cc COMBUSTION CHAMBERS

PART NO.	CONFIGURATION FOR USE	MAX. LIFT
13400010	Bare Head	
13401112	1.437" Dual Springs for Hydraulic Roller or Solid Flat Tappet Cam	.650"
13401113	1.550" Dual Springs for Solid Roller Cam	.700"

#### 62cc COMBUSTION CHAMBERS

PART NO.	CONFIGURATION FOR USE	MAX. LIFT
13410010	Bare Head	
13411112	1.437" Dual Springs for Hydraulic Roller or Solid Flat Tappet Cam	.650"
13411113	1.550" Dual Springs for Solid Roller Cam	.700"

BILLET

HON

SBF

BBC

LS

SBC

ACCESS

MANIFOLDS

HEADS

BLOCKS

TOP END KITS

SHORT BLOCKS



# 20° 215cc SMALL BLOCK FORD CAST IRON CYLINDER HEADS

## QUICK INFO >>>

Serious street performance, mild bracket racing and oval track. Maximum torque and throttle response from idle to 6,800 RPM. Best for 347-427 cubic inch engines. Works with most standard components.

Made from premium Cast Iron and precision machined on our digital CNC machining centers, Iron Eagle's are ready to go right out of the box. Intake runners feature streamlined valve guide bosses for improved airflow.

Standard valve angle and spacing is retained for bolt on compatibility. Manganese Bronze valve guides are used for long life, and hardened valve seats provide durability with unleaded fuels.

Assemblies include Stainless Steel valves, premium springs, locks, retainers, studs, guide plates and seals.

**Heads are sold individually.**

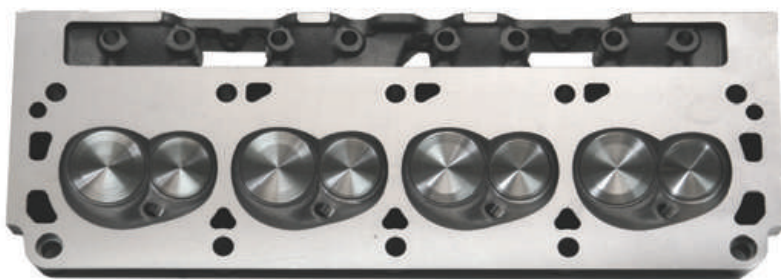

Head parts kit - see page 115.

Uses 3/8" screw-in rocker studs.  
7/16" upgrade available

Assemblies with 1.550" valve spring  
use +.100" long valves.

## IRON EAGLE 20° 215cc SPECS

Material:	220 BHN Cast Iron
Valve Angle:	20° (stock)
Intake Port Volume:	215cc
Intake Valve:	2.050"
Exhaust Valve:	1.600"
Chamber Volume:	58 or 62cc

## FLOW DATA @ 28" WATER

LIFT	INTAKE	EXHAUST
.200"	150	112
.300"	205	139
.400"	255	152
.500"	287	159
.600"	299	161
.700"	304	163

## IRON EAGLE 20° 215cc - IRON (w/ 2.050" Intake Valve)

### 58cc COMBUSTION CHAMBERS

PART NO.	CONFIGURATION FOR USE	MAX. LIFT
13500020	Bare Head	
13501122	1.437" Dual Springs for Hydraulic Roller or Solid Flat Tappet Cam	.650"
13501123	1.550" Dual Springs for Solid Roller Cam	.700"

### 62cc COMBUSTION CHAMBERS

PART NO.	CONFIGURATION FOR USE	MAX. LIFT
13520020	Bare Head	
13521122	1.437" Dual Springs for Hydraulic Roller or Solid Flat Tappet Cam	.650"
13521123	1.550" Dual Springs for Solid Roller Cam	.700"



# 20° SMALL BLOCK FORD 170cc CAST ALUMINUM CYLINDER HEADS

### QUICK INFO >>>

Excellent street, strip, oval track and truck or marine performance upgrade. Maximum torque and throttle response from idle to 6,000 RPM. Best for 302-351 cubic inch engines. Works with most standard components.

Small block Ford PRO1 20° 170cc Aluminum cylinder heads feature high flowing as cast ports with profiled valve guide bosses and are bowl blended on 5-axis CNC machining centers.

Standard valve angle and spacing is retained for bolt on compatibility. Exhaust runners are raised .135" for improved flow. Manganese Bronze valve guides are used for long life, and hardened valve seats provide durability with unleaded fuels.

Assemblies include Stainless Steel valves, premium springs, locks, retainers, studs, guide plates and seals.

**Heads are sold individually.**

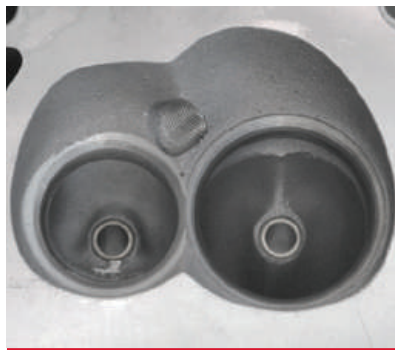

Head parts kit - see page 115.

Uses 3/8" screw-in rocker studs.  
7/16" upgrade available.

### PRO1 20° 170cc - ALUMINUM

#### 58cc COMBUSTION CHAMBERS

PART NO.	CONFIGURATION FOR USE	MAX. LIFT
13100080	Bare Head	
13101181	1.250" Single Springs for Hydraulic Flat Tappet Cam	.510"
13101182	1.437" Dual Springs for Hydraulic Roller or Solid Flat Tappet Cam	.650"

#### 62cc COMBUSTION CHAMBERS

PART NO.	CONFIGURATION FOR USE	MAX. LIFT
13110080	Bare Head	
13111181	1.250" Single Springs for Hydraulic Flat Tappet Cam	.510"
13111182	1.437" Dual Springs for Hydraulic Roller or Solid Flat Tappet Cam	.650"

### PRO1 20° 170cc SPECS

Material:	RMR Cast Aluminum Alloy
Valve Angle:	20° (stock)
Intake Port Volume:	170cc
Intake Valve:	1.940"
Exhaust Valve:	1.600"
Chamber Volume:	58 or 62cc

### FLOW DATA @ 28" WATER

LIFT	INTAKE	EXHAUST
.200"	137	112
.300"	200	151
.400"	240	171
.500"	251	173
.600"	261	172

BILLET

HON

SBF

BBC

LS

SBC

ACCESS

MANIFOLDS

HEADS

BLOCKS

TOP END KITS

SHORT BLOCKS



# 20° 195cc SMALL BLOCK FORD CAST ALUMINUM CYLINDER HEADS

## QUICK INFO >>>

*Serious performance upgrade for street, mild bracket racing and oval track racing. Maximum torque and throttle response from idle to 6,800 RPM. Best for 347-427 cubic inch engines. Works with most standard components.*

PRO1 20° 195cc Aluminum cylinder heads feature increased airflow for larger engines and higher RPM usage.

Standard valve angle and spacing is retained for bolt on compatibility. Exhaust runners are raised .135" for improved flow. Manganese Bronze valve guides are used for long life, and hardened valve seats provide durability with unleaded fuels. Features both 2.500" and 3.000" exhaust bolt patterns.

Assemblies include Stainless Steel valves, premium springs, locks, retainers, studs, guide plates and seals.

**Heads are sold individually.**

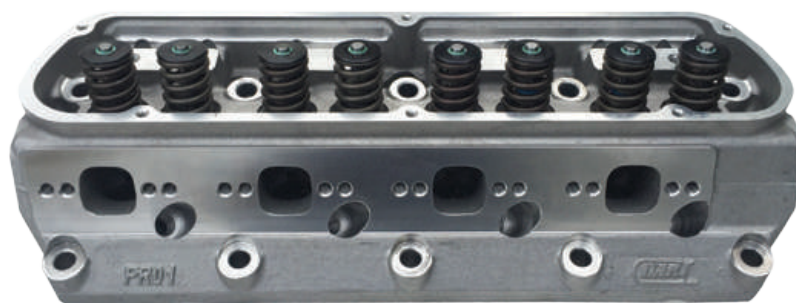
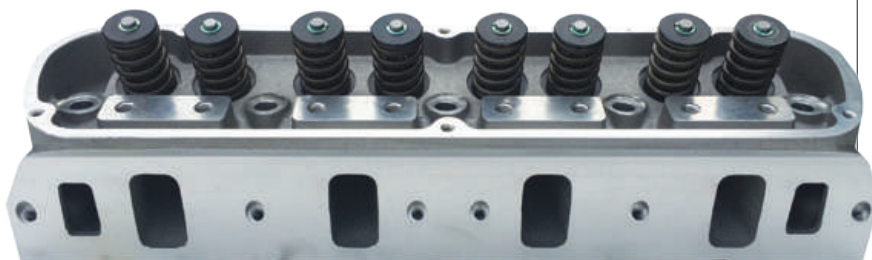

Head parts kit - see page 115.

Uses 3/8" screw-in rocker studs.  
 7/16" upgrade available.

Assemblies with 1.550" valve spring use +.100" long valves.

## PRO1 20° 195cc SPECS

Material:	RMR Cast Aluminum Alloy
Valve Angle:	20° (stock)
Intake Port Volume:	195cc
Intake Valve:	2.020"
Exhaust Valve:	1.600"
Chamber Volume:	58 or 62cc

## FLOW DATA @ 28" WATER

LIFT	INTAKE	EXHAUST
.200"	145	112
.300"	205	151
.400"	246	171
.500"	272	173
.600"	283	172
.700"	288	185

## PRO1 20° 195cc - ALUMINUM

### 58cc COMBUSTION CHAMBERS

PART NO.	CONFIGURATION FOR USE	MAX. LIFT
13200010	Bare Head	
13201111	1.250" Single Springs for Hydraulic Flat Tappet Cam	.510"
13201112	1.437" Dual Springs for Hydraulic Roller or Solid Flat Tappet Cam	.650"
13201113	1.550" Dual Springs for Solid Roller Cam	.700"

### 62cc COMBUSTION CHAMBERS

PART NO.	CONFIGURATION FOR USE	MAX. LIFT
13210010	Bare Head	
13211111	1.250" Single Springs for Hydraulic Flat Tappet Cam	.510"
13211112	1.437" Dual Springs for Hydraulic Roller or Solid Flat Tappet Cam	.650"
13211113	1.550" Dual Springs for Solid Roller Cam	.700"



**20°  
210cc  
CNC**

# SMALL BLOCK FORD CAST ALUMINUM CYLINDER HEADS

### QUICK INFO >>>

*Excellent street, strip, oval track and truck or marine performance upgrade. Maximum torque and throttle response from 3,000 to 7,000+ RPM. Best for 347-427 cubic inch engines. Works with most standard components.*

Dart PRO1 20° 210cc CNC heads for Ford small blocks are professional quality competition cylinder heads. We applied the airflow technology developed in our championship winning Pro Stock engine program to produce these state of the art heads.

Exhaust runners are raised .135" for improved flow. Manganese Bronze valve guides are used for long life, and hardened valve seats provide durability with unleaded fuels. Features 2.500" and 3.000" exhaust bolt pattern.

Assemblies include Stainless Steel valves, premium springs, locks, retainers, studs, guide plates and seals.

**Heads are sold individually.**

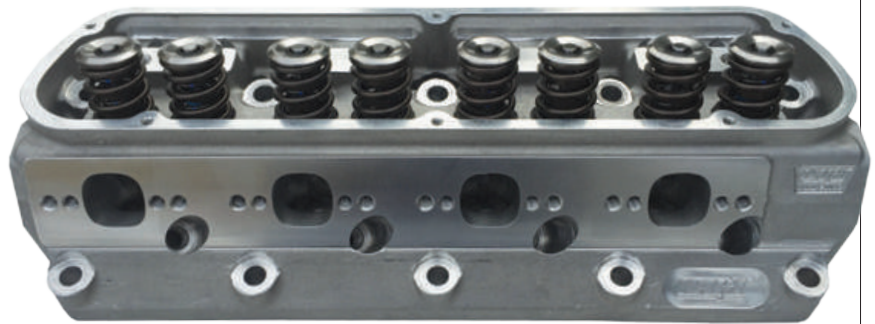

Head parts kit - see page 115.

Uses 7/16" screw-in rocker studs.

Assemblies with 1.550" valve spring use +.100" long valves.

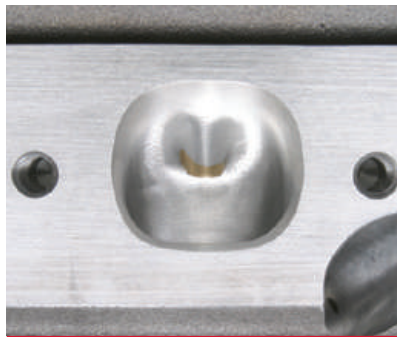

### PRO1 20° 210cc CNC - ALUMINUM

#### 62cc COMBUSTION CHAMBERS

PART NO.	CONFIGURATION FOR USE	MAX. LIFT
13071020	Bare Head	
13071122	1.437" Dual Springs for Hydraulic Roller or Solid Flat Tappet Cam	.650"
13071123	1.550" Dual Springs for Solid Roller Cam	.700"

### PRO1 20° 210cc CNC SPECS

Material:	RMR Cast Aluminum Alloy
Valve Angle:	20° (stock)
Intake Port Volume:	210cc CNC
Intake Valve:	2.050"
Exhaust Valve:	1.600"
Chamber Volume:	62cc

### FLOW DATA @ 28" WATER

LIFT	INTAKE	EXHAUST
.200"	132	108
.300"	195	151
.400"	252	187
.500"	287	203
.600"	305	208
.700"	304	212

BILLET

HON

SBF

BBC

LS

SBC

ACCESS

MANIFOLDS

HEADS

BLOCKS

TOP END KITS

SHORT BLOCKS



**20°  
225cc  
CNC**

## SMALL BLOCK FORD CAST ALUMINUM CYLINDER HEADS

### QUICK INFO >>>

*Serious street performance, mild bracket racing and oval track. Maximum torque and throttle response from 3,500 to 7,800 RPM. Best for 363-427 cubic inch engines. Works with most standard components.*

Every intake port, exhaust runner, valve bowl, and every combustion chamber is 100% CNC machined on special dedicated PRO1 castings. These heads are ideal for high compression, big cubic inch small blocks and are great for supercharged applications.

Exhaust runners are raised .135" for improved flow. Manganese Bronze valve guides are used for long life, and hardened valve seats provide durability with unleaded fuels. Features 3.000" exhaust bolt pattern.

Assemblies include Stainless Steel valves, premium springs, locks, retainers, studs, guide plates and seals.

**Heads are sold individually.**



Head parts kit - see page 115.

Uses 7/16" screw-in rocker studs.

Assemblies with 1.550" valve spring use +.100" long valves.

### PRO1 20° 225cc CNC SPECS

Material:	RMR Cast Aluminum Alloy
Valve Angle:	20° (stock)
Intake Port Volume:	225cc CNC
Intake Valve:	2.080"
Exhaust Valve:	1.600"
Chamber Volume:	62cc

### FLOW DATA @ 28" WATER

LIFT	INTAKE	EXHAUST
.200"	136	115
.300"	201	164
.400"	259	205
.500"	300	225
.600"	323	231
.700"	325	238

### PRO1 20° 225cc CNC - ALUMINUM

#### 62cc COMBUSTION CHAMBERS

PART NO.	CONFIGURATION FOR USE	MAX. LIFT
13072040	Bare Head	
13072142	1.437" Dual Springs for Hydraulic Roller or Solid Flat Tappet Cam	.650"
13072143	1.550" Dual Springs for Solid Roller Cam	.700"



# SMALL BLOCK FORD INTAKE MANIFOLDS

An engine's cylinder heads and intake manifold must work together as an integrated system to produce maximum performance. The intake charge should make a seamless transition from the manifold runners to the cylinder head ports. Dart has taken this into consideration for every intake manifold we sell.

## DUAL PLANE

PART NO	DESCRIPTION	PORT STYLE	DECK	CARB
44811000	SBF Manifold	Rectangle	8.200	4150
44814000	SBF Manifold	Rectangle	9.500	4150

## SINGLE PLANE

PART NO	DESCRIPTION	PORT STYLE	DECK	CARB
44411000	SBF Manifold	Rectangle	8.200	4150
44814000	SBF Manifold	Rectangle	9.500	4150

44411000

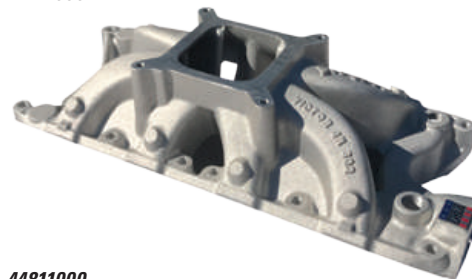

44811000

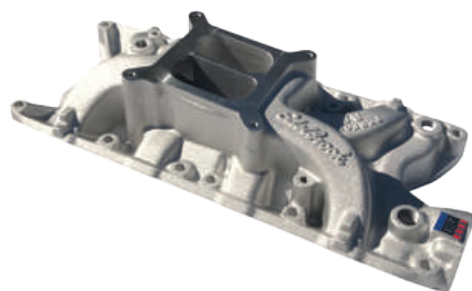

44414000

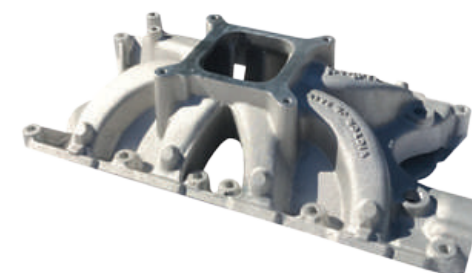

44814000

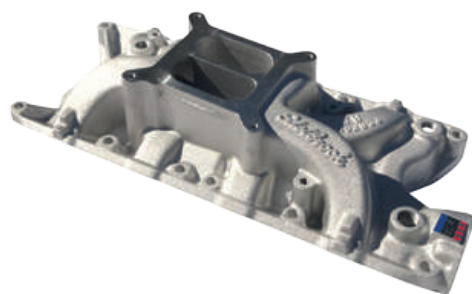

BILLET

HON

SBF

BBC

LS

SBC

ACCESS

MANIFOLDS

HEADS

BLOCKS

TOP END KITS

SHORT BLOCKS

# SMALL BLOCK FORD ACCESSORIES

## VALVE COVERS

Our extra tall valve covers are designed to clear racing valve trains and stud girdles, and to specifically fit Dart cylinder heads

Fabricated Aluminum valve covers mount through tubes welded directly to the valve covers, to help maintain gasket rail flatness and prevent leaks. They feature a tall design that will clear most rocker combinations as well as stud girdles and have the Dart Logo CNC machined into them. Valve cover sets include gaskets and mounting hardware.

### VALVE COVERS

#### SMALL BLOCK FORD

PART NO.	DESCRIPTION	FITS
68000110	Fabricated Aluminum Valve Cover Set	Dart SBF

*Note: Uses stock 302 valve cover gasket.*



## VALVE TRAIN STABILIZERS

Valve train stabilizers also known as “stud girdles” improve the performance and reliability of engines equipped with stud mounted rocker arms. Extra long adjusting nuts are tightly clamped between rigid Aluminum bars that prevent stud deflection under high loads. The valve motion more closely follows the cam profile, producing more power and reducing breakage. Unlike “universal” girdles, these valve train stabilizers are designed to fit the specific valve locations, valve angles, and valve lengths in Dart cylinder heads. Kits include hardened poly-lock adjusting nuts.

### VALVE TRAIN STABILIZERS

PART NO.	DESCRIPTION	FITS
64110005	Valve Train Stabilizer w/ 3/8" polylocks	Dart SBF
64110006	Valve Train Stabilizer w/ 7/16" polylocks	Dart SBF



## HEAD PARTS KITS

Dart parts kits include everything you need to assemble a cylinder head: Stainless Steel valves, springs, locks, retainers, seals, studs, and guide plates. These kits contain the same high quality components we use in our cylinder head assemblies. Each kit does one cylinder head.

### SMALL BLOCK FORD HEAD PARTS KITS (INCLUDES STEEL RETAINERS)

PART NO.	INT.	EXH.	SPRING
28622000F	1.940"	1.600"	1.250" single
28622300F	1.940"	1.600"	1.437" double
28111000F	2.020"	1.600"	1.250" single
28112000F	2.020"	1.600"	1.437" double
28113000F	2.020"	1.600"	1.550" double
28211000F	2.050"	1.600"	1.250" single
28212000F	2.050"	1.600"	1.437" double
28223000F	2.050"	1.600"	1.550" double
28422000F	2.080"	1.600"	1.437" double
28423000F	2.080"	1.600"	1.550" double

### SBF OIL FILTER ADAPTER

PART NO.	DESCRIPTION
32940000	SBF Oil Filter Adapter for use with SBF Dart Blocks



### SBF ADJUSTABLE GUIDE PLATES

PART NO.	DESCRIPTION
27001410	adjustable guide plate 5/16" each
27001410-4	adjustable guide plates 5/16" Set of 4 (does one head)





# HONDA B-20 SERIES CAST ALUMINUM ENGINE BLOCKS

### QUICK INFO >>>

Dart offers the Honda block in two versions that replace B18 and B20 castings. Both are built to withstand the extreme cylinder pressures created by turbochargers and nitrous oxide injection.

We increased wall thickness in all critical areas and we beefed up the bottom end with steel main bearing caps. Best of all, Dart blocks are compatible with production Honda cylinder heads, internal components and accessories.

### FEATURES

- Dart B20 block has extra tall 226mm deck height and choice of standard 81.5mm bore or 84.5mm bore.
- Replaceable Ductile Iron dry sleeves are fully supported to reduce bore distortion and enhance ring seal.
- Closed deck design increases rigidity and improves head gasket sealing.
- Steel main caps with high strength bolts increase bottom end strength and minimize bearing bore distortion.
- Strengthened main webs increase rigidity and improves head gasket and sleeve life.
- Extra large water jackets enhance coolant circulation around cylinder barrels.
- Machined for piston oil sprayers (not included) to reduce piston temperatures and prevent detonation.
- Uses stock components, including oil pan, oil pump, water pump, alternator, and timing belt tensioner.

**NOTE: 212mm decks are discontinued.**

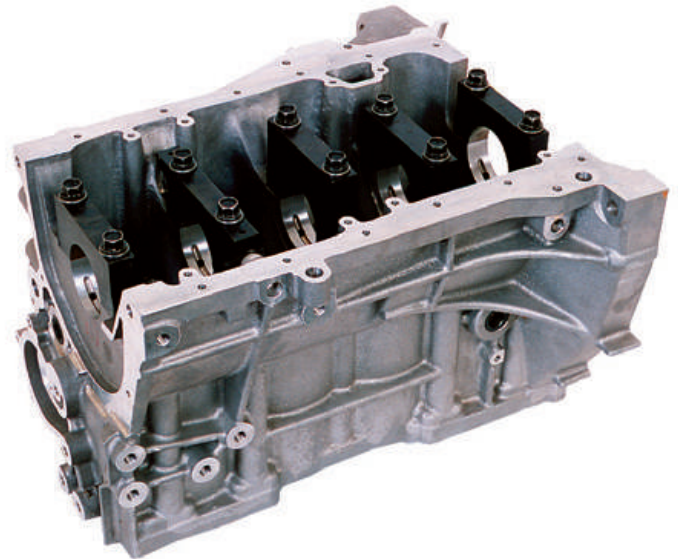
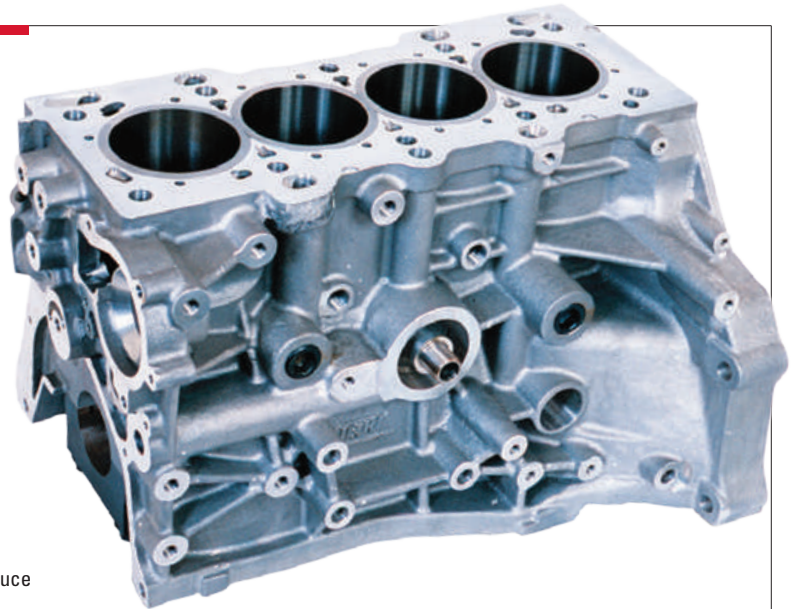

### HONDA B-SERIES - ALUMINUM

PART NO.	DESCRIPTION	CAPS	MAINS	DECK	BORE
31496702	B20 Block	Steel	Std	226mm	81.5mm
31496802	B20 Block	Steel	Std	226mm	84.5mm

### HONDA B-SERIES SPECS

Material:	RMR Cast Aluminum Alloy
Deck Height:	226mm
Cylinder Bores:	81.5mm or 84.5mm
Main Bearings:	Std.
Main Caps:	Steel
Weight:	67 lbs.

BILLET

HON

SBF

BBC

LS

SBC

ACCESS

MANIFOLDS

HEADS

BLOCKS

TOP END KITS

SHORT BLOCKS

**DART**

# BILLET

**TRUSTED BY THE BEST OF THE BEST!**

## **BBC BILLET BLOCKS**

- 5.000", 5.200" & 5.300" bore space
- Deck heights up to 12.500"
- High capacity water jackets
- Custom lifter options
- Cam tunnel options up to 70mm
- Raised cam locations up to +1.915"

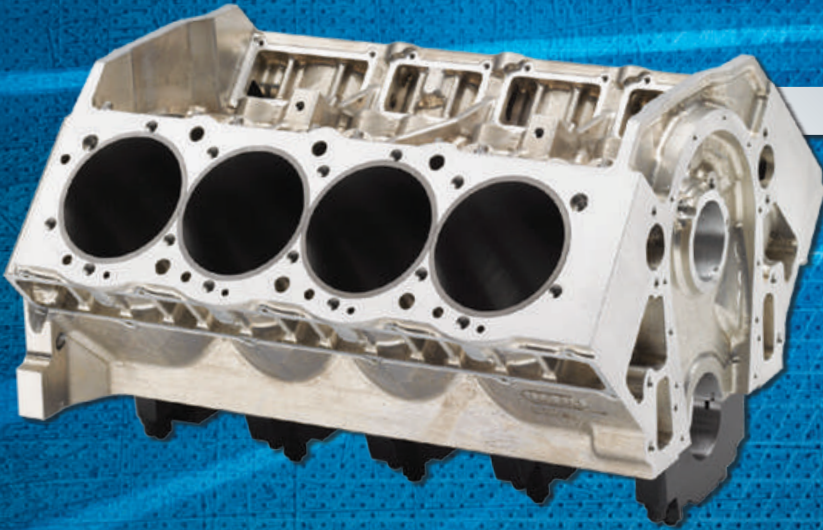

## **BBC BILLET ALUMINUM HEADS**

- 5.000", 5.200" & 5.300" bore space
- Spread port or symmetrical port
- High capacity water jackets
- Copper seats

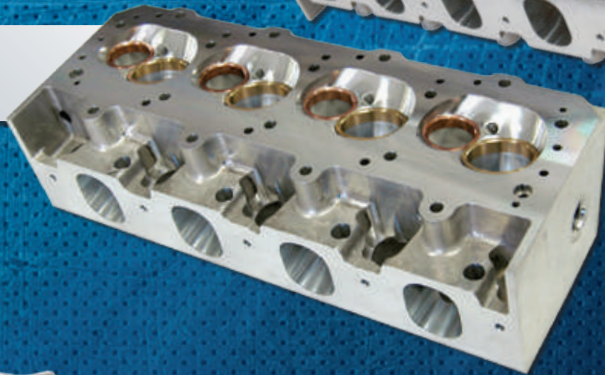

## **SBC BILLET BLOCKS**

- Forged 6061 Aerospace Alloy
- Custom machined for your application
- Custom deck height options
- Cylinder bore spacing: standard or 4.500"
- Raised camshaft locations
- Cam tunnel options up to 60mm
- Custom lifter diameters and locations
- Steel or optional Aluminum main caps
- Full water jackets



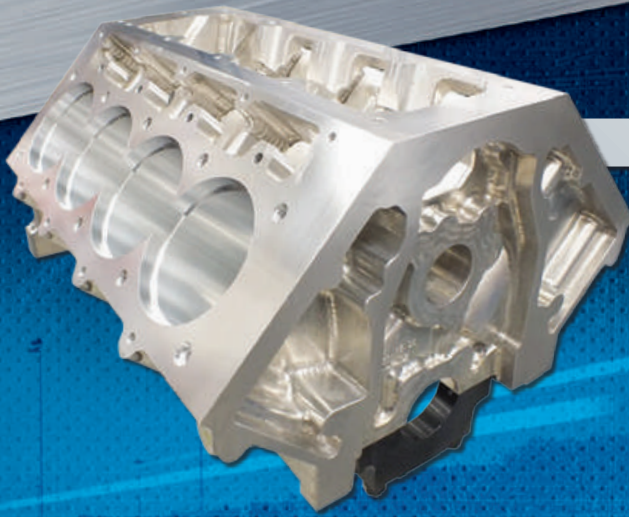

### **LS / LS NEXT BILLET BLOCKS**

- Forged 6061 Aerospace Alloy
- Custom machined for your application
- Custom deck height options
- Raised camshaft locations
- Cam tunnel options up to 60mm
- Custom lifter diameters
- Steel or optional Aluminum main caps
- Available with LS NEXT<sup>2</sup> upgrade
- Full water jackets

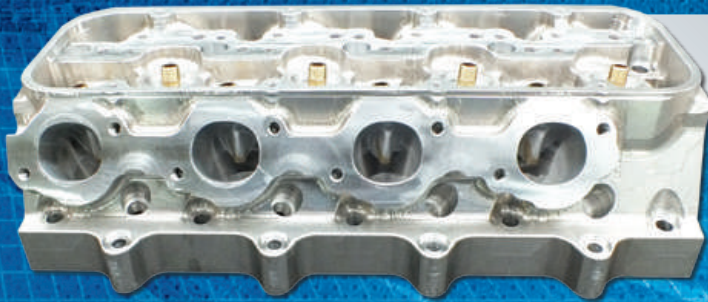

### **LS BILLET ALUMINUM HEADS**

- 4.400" bore space
- Symmetrical ports
- High capacity water jackets or solid
- Copper seats
- 6 bolt per cylinder
- 6061 Billet Alloy

### **SBF BILLET BLOCKS**

- Forged 6061 Aerospace Alloy
- Custom machined for your application
- Custom deck height options
- Cylinder bore spacing: standard or 4.500"
- Raised camshaft locations
- Cam tunnel options up to 60mm
- Custom lifter diameters and locations
- Steel or optional Aluminum main caps
- Full water jackets



**CUSTOM BILLET BLOCKS CAN BE ENGINEERED TO CUSTOMER SPECIFICATION.**



Precision machined from a solid Billet of Aerospace Aluminum, Dart Billet blocks offer virtually unlimited choices in bore centerline, deck height, bore diameter, lifter and cam options.

# ACCESSORIES & SERVICE PARTS

Dart stocks a wide variety of parts and accessories.

## BLOCK PARTS KITS

Dart block parts kits include the same quality components we use in our performance engine blocks. Each kit includes coated cam bearings, freeze plugs and dowel pins for timing cover and oil pump (see page 107 for details).

## STUD KITS & STUDS

High quality studs and stud kits, for maximum strength and thread engagement. Premium materials with rolled threads and centerless ground shanks. Stud lengths are optimized for use with Dart blocks and heads.

## VALVES

We stock a huge inventory of Stainless Steel, Inconel and Titanium valves in a wide range of diameters and lengths. Please call with your specific requirements.

## VALVE SPRINGS

Our in-house engine research and development program and our daily contact with top engine builders have taught us which springs will perform under the stress of competition. We offer valve springs for all types of engines, including street performance, oval track, and drag racing. Call us for the right spring for your combination.

## SEATS AND GUIDES

Our Ductile Iron valve seats are machined from continuous cast solid bars. We heat treat our intake and exhaust seats to different specifications because of the different environments in which they operate. Replacement valve guides and guide liners are available for all Dart heads.

## GASKETS

We have gaskets to fit every cylinder head we sell - including hard to find valve cover and exhaust gaskets. Most intake manifold gaskets are available in several thicknesses to maintain port alignment with milled blocks and heads. We carry composite and other head gaskets in a variety of bore sizes and thicknesses.

## SLEEVES

Premium quality sleeves are manufactured from high strength Ductile Iron. Oversize sleeves available for restoring Dart Aluminum blocks to like new condition.

## CAM BEARINGS

Dart's high quality cam bearings are prepared with a special coating for enhanced durability and features three oil hole with a 360° annulus for improved oiling.

## ASSEMBLY LUBRICANT

CMD Extreme Pressure Lube is capable of withstanding high temperatures and pressures of up to 50,000 PSI. It reduces galling, frictional heat and scoring caused by metal to metal contact. Used as an assembly lubricant, it produces more accurate torque readings and higher clamping loads.

## ARALDITE RAPID EPOXY

We import this amazing epoxy from England because it's the best in the world. We use it in our own engine shop daily. This two part epoxy cures in minutes, so you can keep working instead of waiting for it to harden.

## REPAIRS

When an engine disaster strikes, you can count on Dart Machinery to make it right. We offer repair services for all Dart cylinder heads. Our cylinder head specialists can bring dead heads back to life. Dart can weld chambers, repair ports, water jackets, and install new seats and guides. Prices are based on condition of head and extent of damage.

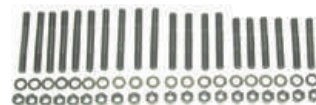

# ACCESSORIES & SERVICE PARTS

## SMALL BLOCK CHEVY HEAD PARTS KITS

Includes valves, springs, steel retainers, locks, guide plates, studs, and seals (per head).

PART NO.	VALVES	SPRINGS	HEAD TYPE
28111000	2.020"/1.600"	1.250"S 7° locks, retainers	IE, PRO1 180-200
28112000	2.020"/1.600"	1.437"D 10° locks, retainers	IE, PRO1 180-200
28113000	2.020"/1.600"	1.550"D 10° locks, retainers	IE, PRO1 180-200
28112100	2.020"/1.600"	1.290"B Titanium retainers	LS1 Single Spring
28212000	2.050"/1.600"	1.437"D 10° locks, retainers	IE, PRO1 215
28212100	2.050"/1.600"	1.290"B Titanium retainers	LS1 Single Spring
28223000	2.050"/1.600"	1.550"D 10° locks, retainers	IE, PRO1 215
28323000	2.050"/1.625"	1.550"D 10° locks, retainers	IE, PRO1 215
28422000	2.080"/1.600"	1.437"D 10° locks, retainers	IE, PRO1 230
28422200	2.080"/1.600"	1.295"D Titanium retainers	LS1 Double Spring
28423000	2.080"/1.600"	1.550"D 10° locks, retainers	IE, PRO1 230
28811200	2.165"/1.600"	1.290"B	LS3
28812200	2.165"/1.600"	1.295"D	LS3
28821200	2.200"/1.625"	1.290"B Titanium retainers	LS7 Single Spring
28822200	2.200"/1.625"	1.295"D Titanium retainers	LS7 Dual Spring
28823200	2.200"/1.625"	1.310" D Titanium retainers	LS7 Dual Spring (Solid Roller)



## BIG BLOCK CHEVY HEAD PARTS KITS

Includes valves, springs, steel retainers, locks, guide plates, studs, and seals (per head).

PART NO.	VALVES	SPRINGS	HEAD TYPE
28000011	2.250"/1.880"	1.550"S	IE 308, PRO1 275-325
28000012	2.250"/1.880"	1.550"D	IE 308, PRO1 275-325
28000012M	2.250"/1.880"	1.550"H Inconel exhaust	IE 308, PRO1 275-325, marine
28000013	2.250"/1.880"	1.625"D Titanium retainers	IE 308, PRO1 275-325
28000022	2.250"/1.900"	1.550"D	IE 308, PRO1 275-325
28000023	2.250"/1.900"	1.625"D Titanium retainers	IE 308, PRO1 275-325
28000032	2.300"/1.880"	1.550"D	IE 345, PRO1 310-355
28000032M	2.300"/1.880"	1.550"H Inconel exhaust	IE 345, PRO1 310-355, marine
28000033	2.300"/1.880"	1.625"D Titanium retainers	IE 345, PRO1 310-355
28000043	2.300"/1.900"	1.625"D Titanium retainers	IE 345, PRO1 310-355
28000073	2.350"/1.880"	1.625"D Titanium retainers	Big M
28000063	2.350"/1.880"	1.625"D Titanium retainers	365 CNC Head
28000093	2.400"/1.800"	1.625"D	BBC 20°
28000095	2.400"/1.800"	1.625"D	BBC 20°

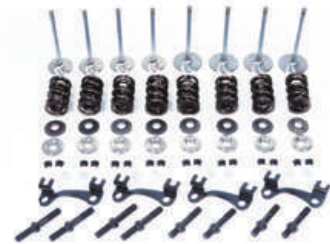

## SMALL BLOCK FORD HEAD PARTS KITS

Includes valves, springs, steel retainers, locks, guide plates, studs, and seals (per head).

PART NO.	VALVES	SPRINGS	HEAD TYPE
28622000F	1.940"/1.600"	1.250"S 7° locks, retainers	Iron Eagle 180
28622300F	1.940"/1.600"	1.437"D 10° locks, retainers	Iron Eagle 180
28111000F	2.020"/1.600"	1.250"S 7° locks, retainers	IE 180-200, PRO1 170-195
28112000F	2.020"/1.600"	1.437"D 10° locks, retainers	IE 180-200, PRO1 170-195
28113000F	2.020"/1.600"	1.550"D 10° locks, retainers	IE 180-200, PRO1 170-195
28211000F	2.050"/1.600"	1.250"S 7° locks, retainers	IE 215, PRO1 210
28212000F	2.050"/1.600"	1.437"D 10° locks, retainers	IE 215, PRO1 210
28223000F	2.050"/1.600"	1.550"D 10° locks, retainers	IE 215, PRO1 210
28422000F	2.080"/1.600"	1.437"D 10° locks, retainers	PRO1 225
28423000F	2.080"/1.600"	1.550"D 10° locks, retainers	PRO1 225



## BLOCK PARTS KITS

PART NO.	BLOCK TYPE
32000013	SHP Small Block Chevy - coated cam bearings, brass freeze plugs, head, front cover, dowel pins & pipe plugs.
32000014	SHP Pro Small Block Chevy - coated BBC cam bearings, brass freeze plugs, head, front cover, dowel pins & pipe plugs.
32000001	Little M Small Block Chevy - coated cam bearings, brass freeze plugs, head, front cover, dowel pins & pipe plugs.
32000011	Iron Eagle Small Block Chevy - coated BBC cam bearings, brass freeze plugs, head, front cover, dowel pins & pipe plugs.
32000012	Aluminum Small Block Chevy - coated BBC cam bearings, screw-in freeze plugs w/ o-rings, head, front cover, dowel pins & pipe plugs.
32000002	Big M Big Block Chevy - coated cam bearings, brass freeze plugs, head, front cover, dowel pins & pipe plugs.
32000005	BIG M PRO/Race Block - coated cam bearings, brass freeze plugs, head, front cover, dowel pins & pipe plugs.
32000006	Aluminum Big Block Chevy - coated cam bearings, screw-in freeze plugs, head, front cover, dowel pins & pipe plugs.
32000015	SHP Small Block Ford - coated cam bearings, brass freeze plugs, head, front cover, dowel pins & pipe plugs.
32000003	Iron Small Block Ford - coated cam bearings, brass freeze plugs, head, front cover, dowel pins & pipe plugs.
32000004	Aluminum Small Block Ford - coated cam bearings, screw-in freeze plugs, head, front cover, dowel pins & pipe plugs.
32000009	Honda Block - timing tensioner pin, threaded freeze plugs, dipstick tube.
32000016	LS Next Iron - coated cam bearings, brass freeze plugs, dowel pins & pipe plugs.
32000017	LS Next Aluminum - coated cam bearings, screw-in freeze plugs w/ o-rings, dowel pins & pipe plugs.
64210240	Big Block Chevy Inside Head Stud Kit (4 studs, nuts, washers, and shoes).
32000018	LS NEXT SHP Iron / LS Next SHP PRO
32000019	LS NEXT Skirted Aluminum.
32000118F	LS1, LS2, LS3 LS NEXT SHP/Skirted windage tray fasteners kit.
32000119F	LS7 LS NEXT SHP/Skirted windage tray fasteners kit.

BILLET

HON

SBF

BBC

LS

SBC

ACCESS

MANIFOLDS

HEADS

BLOCKS

TOP END KITS

SHORT BLOCKS

# ACCESSORIES & SERVICE PARTS

## LUBRICANTS & EPOXIES

PART NO.	DESCRIPTION
70000003	Araldite Rapid Epoxy - 30ml
70000009	Dart Assembly Lubricant - 8 oz
70000009-12	Dart Assembly Lubricant, Case
LUBE	CMD #3 Assembly Lubricant - 4 oz

## ENGINE BAG

PART NO.	DESCRIPTION
BAG-ENGINE	Dart Engine Bag

## SMALL BLOCK CHEVY BLOCK SLEEVES

(Old Style SBC = black) (New Style SBC = red)

PART NO.	DECK	BORE	LENGTH	O.S.
32110111	9.025"	4.000"	5.625"	
32110112	9.025"	4.000"	5.625"	+ .010"
32110113	9.025"	4.000"	5.625"	+ .020"
32110121	9.325"	4.000"	5.925"	
32110122	9.325"	4.000"	5.925"	+ .010"
32110123	9.325"	4.000"	5.925"	+ .020"
32110131	9.500"	4.000"	6.100"	
32110132	9.500"	4.000"	6.100"	+ .010"
32110133	9.500"	4.000"	6.100"	+ .020"
32110141	8.850"	4.000"	5.425"	
32110211	9.025"	4.125"	5.625"	
32110212	9.025"	4.125"	5.625"	+ .010"
32110213	9.025"	4.125"	5.625"	+ .020"
32110221	9.325"	4.125"	5.925"	
32110222	9.325"	4.125"	5.925"	+ .010"
32110223	9.325"	4.125"	5.925"	+ .020"
32110231	9.500"	4.125"	6.100"	
32110232	9.500"	4.125"	6.100"	+ .010"
32110233	9.500"	4.125"	6.100"	+ .020"
32110241	8.850"	4.125"	5.425"	
32110242	8.850"	4.125"	5.425"	+ .010"
32110243	8.850"	4.125"	5.425"	+ .020"
32114111	9.325"	4.180"	6.150"	for 4.500" BS
32120211	9.025"	4.125"	5.825"	
32120212	9.025"	4.125"	5.825"	+ .010"
32120221	9.325"	4.125"	6.125"	
32120222	9.325"	4.125"	6.125"	+ .010"
32120231	9.500"	4.125"	6.300"	
32120232	9.500"	4.125"	6.300"	+ .010"

## LS NEXT BLOCK SLEEVES

PART NO.	DECK	BORE	LENGTH	O.S.
32110251	9.240"	4.125"	5.825"	
32110261	9.750"	4.125"	6.335"	
32110151	9.240"	4.000"	5.825"	
32110161	9.750"	4.000"	6.335"	

\*Add "S" to the part number to specify Single Flat. Single Flat is not available for Honda.

## BIG BLOCK CHEVY BLOCK SLEEVES

PART NO.	DECK	BORE	LENGTH	O.D.	FLANGE
32160111	9.800"	4.250"	6.370"	4.740"	4.940"
32160121	10.200"	4.250"	6.770"	4.740"	4.940"
32160131	10.400"	4.250"	7.000"	4.740"	4.940"
32160211	9.800"	4.500"	6.370"	4.740"	4.940"
32160221	10.200"	4.500"	6.770"	4.740"	4.940"
32160231	10.400"	4.500"	7.000"	4.740"	4.940"
32160311	9.800"	4.600"	6.370"	4.740"	4.940"
32160321	10.200"	4.600"	6.770"	4.740"	4.940"
32160331	10.400"	4.600"	7.000"	4.740"	4.940"
32160411	Custom	4.650"	8.200"	4.880"	5.045"
32160511	Custom	4.650"	8.200"	4.860"	5.200"
32160611	Custom	4.950"	8.250"	5.130"	5.380"

## SMALL BLOCK FORD BLOCK SLEEVES

PART NO.	DECK	BORE	LENGTH	O.S.
32140111	8.200"	4.000"	5.175"	
32140112	8.200"	4.000"	5.175"	+ .010"
32140113	8.200"	4.000"	5.175"	+ .020"
32140121	8.700"	4.000"	5.650"	
32140123	8.700"	4.000"	5.650"	+ .020"
32140131	9.200"	4.000"	5.575"	
32140132	9.200"	4.000"	5.575"	+ .010"
32140133	9.200"	4.000"	5.575"	+ .020"
32140141	9.500"	4.000"	5.850"	
32140142	9.500"	4.000"	5.850"	+ .010"
32140143	9.500"	4.000"	5.850"	+ .020"
32140211	8.200"	4.125"	5.175"	
32140212	8.200"	4.125"	5.175"	+ .010"
32140213	8.200"	4.125"	5.175"	+ .020"
32140221	8.700"	4.125"	5.650"	
32140222	8.700"	4.125"	5.650"	+ .010"
32140223	8.700"	4.125"	5.650"	+ .020"
32140231	9.200"	4.125"	5.575"	
32140232	9.200"	4.125"	5.575"	+ .010"
32140233	9.200"	4.125"	5.575"	+ .020"
32140241	9.500"	4.125"	5.850"	
32140242	9.500"	4.125"	5.850"	+ .010"
32140243	9.500"	4.125"	5.850"	+ .020"

## HONDA BLOCK SLEEVES

PART NO.	DECK	BORE	LENGTH	O.S.
32180541	211.5mm	3.200" (81.5mm)	5.500"	
32180542	211.5mm	3.200" (81.5mm)	5.500"	+ .010
32180543	211.5mm	3.200" (81.5mm)	5.500"	+ .020
32180551	226mm	3.200" (81.5mm)	6.000"	
32180552	226mm	3.200" (81.5mm)	6.000"	+ .010
32180553	226mm	3.200" (81.5mm)	6.000"	+ .020
32180641	211.5mm	3.300" (84.5mm)	5.500"	
32180642	211.5mm	3.300" (84.5mm)	5.500"	+ .010
32180643	211.5mm	3.300" (84.5mm)	5.500"	+ .020
32180651	226mm	3.300" (84.5mm)	6.000"	
32180652	226mm	3.300" (84.5mm)	6.000"	+ .010
32180653	226mm	3.300" (84.5mm)	6.000"	+ .020

## FRONT COVERS, TIMING CHAINS & DRIVES

PART NO.	DESCRIPTION
67110002	Timing Chain Set - Cam .390" Raised
67240002	Front Cover - BBC Cam .400" Raised w/Gasket
67140005	Front Cover - Gen 7/8.1 w/Cam Sensor Provision

# ACCESSORIES & SERVICE PARTS

## SMALL BLOCK CHEVY COATED CAM BEARINGS

PART NO.	DESCRIPTION
32210010	2.120" Standard Set (Iron Eagle/SHP Pro/BBC core)
32210011	2.120" Standard
32210012	Oversize 2.120" +.010"
32210013	Oversize 2.120" +.020"
32210014	Oversize 2.120" +.030"
32210020	2.000" Standard Set (SHP, Little M)
32210021	2.000" Standard (SHP, Little M)
32210022	Oversize 2.000" +.010"
32210023	Oversize 2.000" +.020"
32210024	Oversize 2.000" +.030"

## SMALL BLOCK CHEVY COATED CAM BEARINGS

PART NO.	DESCRIPTION
32210100	55mm Babbitt Set (2 wide, 3 narrow)
32210101	55mm Babbitt #1, #5 (.780"/.770" wide)
32210102	Oversize 55mm Babbitt #1, #5 +.010"
32210103	Oversize 55mm Babbitt #1, #5 +.020"
32210104	Oversize 55mm Babbitt #1, #5 +.030"
32210105	55mm Babbitt #2, #3, #4 (.640"/.630" wide)
32210106	Oversize 55mm Babbitt #2, #3, #4 +.010"
32210107	Oversize 55mm Babbitt #2, #3, #4 +.020"
32210108	Oversize 55mm Babbitt #2, #3, #4 +.030"

## BIG BLOCK CHEVY COATED CAM BEARINGS

PART NO.	DESCRIPTION
32210030	Standard Set (Big M)
32210031	Standard Each (Big M)
32210032	Oversize +.010"
32210033	Oversize +.020"
32210034	Oversize +.030"
32210101-5	55mm Babbit Set
32210101	55mm Babbit Each
32210200	60mm Babbitt Set
32210201	60mm Babbitt Each
32220050	Race Series Standard Set
32220051	Race Series Standard 2.253"

## SMALL BLOCK FORD COATED CAM BEARINGS

PART NO.	DESCRIPTION
32210041	Standard Set (SHP, Sportsman, Iron Eagle)
32210042	Oversize +.010" Set
32210043	Oversize +.020" Set
32210051	2.081 Standard #1
32210052	Oversize +.010" #1
32210053	Oversize +.020" #1
32210061	Standard #2
32210062	Oversize +.010" #2
32210063	Oversize +.020" #2
32210071	Standard #3
32210072	Oversize +.010" #3
32210073	Oversize +.020" #3
32210081	Standard #4
32210082	Oversize +.010" #4
32210083	Oversize +.020" #4
32210091	Standard #5
32210092	Oversize +.010" #5
32210093	Oversize +.020" #5
32210105	55mm Babbit Each

## LS NEXT COATED CAM BEARINGS

PART NO.	DESCRIPTION
32210101-5	55mm Babbitt Set
32210101	55mm Babbitt (.780"/.770" wide)
32210102	Oversize 55mm Babbitt +.010"
32210103	Oversize 55mm Babbitt +.020"
32210104	Oversize 55mm Babbitt +.030"

## ROLLER CAM BEARINGS

PART NO.	DESCRIPTION
32220041	50mm Each
32220041-5	50mm Set
32220042	55mm Each
32220042-5	55mm Set
32220043	60mm Each

## BLOCK COMPONENTS

PART NO.	DESCRIPTION
32810000B	Iron Block Brass Freeze Plug 1-5/8"
32820000B	Iron Block Brass Freeze Plug 1-1/2"
32830000B	Iron Block Brass Freeze Plug 1-1/2" Deep
32310000	Freeze Plug - Threaded (1-5/16" -12) O-Ring not included
32410000	Freeze Plug - O Ring
32510000	Freeze Plug - SBC Cam Bore 2.375" / 55mm Babbit
32540000	Freeze Plug - SHP 2.106 Cam Bore
32520000	Freeze Plug - BBC Cam Bore
32530000	Freeze Plug - 55 MMR Cam Bore
32550000	Freeze Plug - 60 MMR Cam Bore
32610000	Snap Ring - Cam Plug
32620000	Snap Ring - Cam Plug 2.500"
32650000	Snap Ring - Cam Plug 60 MMR
32910000	Dowel Pin - Timing Cover
32920000	Dowel Pin - Oil Pump
32930000	Standard Lifter Bushing BBC No Through Hole 1.062" OD
32930001	Standard Lifter Bushing w/Through Hole BBC
32930100	Lifter Bushing - 55mm SBC only
32930200	Lifter Bushing - 55mm BBC only
32930400	Keyed Ford Lifter Bushing 1.062" OD x .926" ID
32931000	Keyed Lifter Bushing 1.062" OD x .925" ID
32931010	Keyed Lifter Bushing 1.065" OD x .925" ID
32932000	Keyed Lifter Bushing 1.187" OD x 1.050" ID
32933000	Keyed Lifter Bushing 1.222" OD x 1.080" ID
32940000	Oil Filter Adapter - SB Ford
PR200FP	Fuel Pump Pushrod +.200" (Iron Eagle small block)
32010100	Honda Dipstick Tube

## SMALL BLOCK CHEVY MAIN CAPS - HONE READY

PART NO.	BLOCK TYPE	STYLE	MAINS	POSITION	MATERIAL
32711010H	Aluminum	4 Bolt	350	Full Set	Steel
32711020H	Aluminum	4 Bolt	350	Front	Steel
32711030H	Aluminum/IE	4 Bolt	350	Interior	Steel
32711050H	Aluminum/IE	4 Bolt	350	Rear	Steel
32712010H	Aluminum	4 Bolt	400	Full Set	Steel
32712020H	Aluminum	4 Bolt	400	Front	Steel
32712030H	Aluminum	4 Bolt	400	Interior	Steel
32712050H	Aluminum	4 Bolt	400	Rear	Steel
32721014H	Iron Eagle	4 Bolt	350	Full Set	Steel
32721024H	Iron Eagle	4 Bolt	350	Front	Steel
32722014H	Iron Eagle	4 Bolt	400	Full Set	Steel

BILLET

HON

SBF

BBC

LS

SBC

ACCESS

MANIFOLDS

HEADS

BLOCKS

TOP END KITS

SHORT BLOCKS

# ACCESSORIES & SERVICE PARTS

## SMALL BLOCK CHEVY MAIN CAPS - HONE READY

PART NO.	BLOCK TYPE	STYLE	MAINS	POSITION	MATERIAL
32722024H	Iron Eagle	4 Bolt	400	Front	Steel
32722030H	Iron Eagle	4 Bolt	400	Interior	Steel
32722050H	Iron Eagle	4 Bolt	400	Rear	Steel
32731010H	Little M	4 Bolt	350	Full Set	Steel
32731020H	Little M	4 Bolt	350	Front	Steel
32731030H	Little M	4 Bolt	350	Interior	Steel
32731050H	Little M	4 Bolt	350	Rear	Steel
32732010H	Little M	4 Bolt	400	Full Set	Steel
32732020H	Little M	4 Bolt	400	Front	Steel
32732030H	Little M	4 Bolt	400	Interior	Steel
32732050H	Little M	4 Bolt	400	Rear	Steel
32751010H	Little M	2-4 Bolt	350	Full Set	Ductile
32751020H	Little M	2 Bolt	350	Front	Ductile
32751030H	Little M	4 Bolt	350	Interior	Ductile
32751050H	Little M	2 Bolt	350	Rear	Ductile
32752010H	Little M	2-4 Bolt	400	Full Set	Ductile
32752020H	Little M	2 Bolt	400	Front	Ductile
32752030H	Little M	4 Bolt	400	Interior	Ductile
32752050H	Little M	2 Bolt	400	Rear	Ductile
32791010H	SHP	2-4 Bolt	350	Full Set	Ductile
32791020H	SHP	2 Bolt	350	Front	Ductile
32791030H	SHP	4 Bolt	350	Interior	Ductile
32791050H	SHP	2 Bolt	350	Rear	Ductile

## BIG BLOCK CHEVY MAIN CAPS - HONE READY

PART NO.	BLOCK TYPE	STYLE	MAINS	POSITION	MATERIAL
32763010H	BBC	4 Bolt	Std	Full Set	Steel
32763020H	BBC	4 Bolt	Std	Front	Steel
32763030H	BBC	4 Bolt	Std	Interior	Steel
32763050H	BBC	4 Bolt	Std	Rear	Steel
32773010H	BBC	4 Bolt	Std	Full Set	Ductile
32773020H	BBC	4 Bolt	Std	Front	Ductile
32773030H	BBC	4 Bolt	Std	Interior	Ductile
32773050H	BBC	4 Bolt	Std	Rear	Ductile
32763050VIH	Gen VI	4 Bolt	Std	Rear	Steel
32773050VIIH	8.1 Liter	4 Bolt	Std	Rear	Ductile

## SMALL BLOCK FORD MAIN CAPS - HONE READY

PART NO.	BLOCK TYPE	STYLE	MAINS	POSITION	MATERIAL
32781010H	Iron Eagle	4 Bolt	302	Full Set	Steel
32781020H	Iron Eagle	4 Bolt	302	Front	Steel
32781030H	Iron Eagle	4 Bolt	302	Interior	Steel
32781050H	Iron Eagle	4 Bolt	302	Rear	Steel
32781040H	Iron Eagle	4 Bolt	302	C. Thrust	Steel
32782010H	Iron Eagle	4 Bolt	351	Full Set	Steel
32782040H	Iron Eagle	4 Bolt	351	Interior	Steel
32782050H	Iron Eagle	4 Bolt	351	Rear	Steel
32783010H	Aluminum	4 Bolt	302	Full Set	Steel
32783020H	Aluminum	4 Bolt	302	Front	Steel
32783030H	Aluminum	4 Bolt	302	Interior	Steel
32783050H	Aluminum	4 Bolt	302	Rear	Steel

## SMALL BLOCK FORD MAIN CAPS - HONE READY

PART NO.	BLOCK	STYLE	MAINS	POSITION	MATERIAL
32784010H	Aluminum	4 Bolt	351	Full Set	Steel
32784020H	Aluminum	4 Bolt	351	Front	Steel
32784030H	Aluminum	4 Bolt	351	Interior	Steel
32784050H	Aluminum	4 Bolt	351	Rear	Steel
32785010H	Aluminum	4 Bolt	302/351	Full Set	Steel
32785020H	Aluminum	4 Bolt	302/351	Front	Steel
32785030H	Aluminum	4 Bolt	302/351	Interior	Steel
32785050H	Aluminum	4 Bolt	302/351	Rear	Steel

## HONDA MAIN CAPS - HONE READY

PART NO.	BLOCK	STYLE	MAINS	POSITION	MATERIAL
32701010H	Honda	2 Bolt	Std	Full Set	Steel
32701020H	Honda	2 Bolt	Std	Front/Rear	Steel
32701030H	Honda	2 Bolt	Std	#2	Steel
32701040H	Honda	2 Bolt	Std	#3	Steel
32701050H	Honda	2 Bolt	Std	#4	Steel

## CARB SPACERS/ADAPTERS & LINKAGE KITS

PART NO.	DESCRIPTION
62100000	Spacer - 4150 1/2" Open Phenol
62100001	Spacer - 4150 1/2" Cloverleaf Phenol
62100002	Spacer - 4150 1" Cloverleaf Phenol
62100003	Spacer - 4500 1/4" 4xH Phenol
62100004	Spacer - 4500 1/2" 4xH Phenol
62100005	Spacer - 4500 1" 4xH Phenol
62100006	Spacer - 4500 1" Cloverleaf Phenol
62100008	Spacer - 4500 2" Cloverleaf Phenol
62100007	Adapter 4150 to 4500 2"

## INTAKE SPACER PLATE KITS - W/ END RAIL SPACERS

PART NO.	ENGINE	DESCRIPTION
62210002	SBC	23°, 9.325"
62210003	SBC	23°, 9.500"
62210004	SBC	18°, 9.325"
62210005	SBC	18°, 9.500"
62210001	BBC	24°, 10.200" Rect port
62210010	BBC	24°, 10.200" Oval port
62210009	BBC	18°, 10.200" Rect port (383cc)
62210007	BBC	18°, 10.200" Oval port (330cc)
62210006	BBC	18°, 10.200" Big Chief Rect port
62210012	BBC	14° & 11°, 10.200" Big Chief Oval port

## INTAKE SPACER PLATES (PAIR)

PART NO.	ENGINE	DESCRIPTION
62230004	SBC 23° 9.325"	1/4"
62230003	SBC 23° 9.500"	1/2"
62230005	SBC 18° 9.325"	1/4"
62230002	SBC 18° 9.500"	1/2"
62230009	BBC 24° Rect Port	10.200" 3/8"
62230010	BBC 24° Oval Port	10.200" 3/8"
62230013	BBC 18° Rect Port (383cc)	10.200" 3/8"
62230012	BBC 18° Oval Port (330cc)	10.200" 3/8"
62230006	BBC 18° Big Chief Rect Port	10.200" 3/8"
62230008	BBC 14° & 11° Big Chief Oval Port	10.200" 3/8"



# ACCESSORIES & SERVICE PARTS

## END RAIL SPACERS (PAIR)

PART NO.	ENGINE	DESCRIPTION
62220007	SBC	9.325" 1/4"
62220005	SBC	9.325" 5/16"
62220003	SBC	9.500" 1/2"
62220006	BBC	10.200" 3/8"
62220008	BBC	10.200" 1/4" PRO2 380cc
62220010	BBC	9.800" PRO1 20°
62220011	BBC	10.200" PRO1 20°
62220009	BBC	10.200" 18° 1/2"

## INTAKE GASKETS (EACH)

PART NO.	ENGINE	DESCRIPTION
65111204	SBC	#1204 (SHP, Iron Eagle, PRO1 - 180cc)
65111205	SBC	#1205 (SHP, Iron Eagle, PRO1 - 200cc)
65111206	SBC	#1206 (Iron Eagle, PRO1 - 215cc, 230cc)
65111207	SBC	#1207
65111256	SBC	#1256
65121100	SBC	Raised runner or standard .060"
65121200	SBC	Raised runner or standard .120"
65122100	SBC	18° .060"
65122200	SBC	18° .120"
65127101	SBC	Little Chief .060"
65127201	SBC	Little Chief .125"
65002155	BBC	14° Big Chief large oval port .060"
65002157	BBC	Big Chief small oval port .060"
65002158	BBC	14° Big Chief oval port .120"
65111251	BBC	#1251, trim to fit
65123100	BBC	.060 #121 (Iron Eagle, PRO1, PRO2)
65123200	BBC	.120 (Iron Eagle, PRO1, Pro2)
65123300	BBC	Big M .060"
65123400	BBC	Big M .120"
65123500	BBC	18° Race Series .062"
65123600	BBC	18° Race Series .125"
65124101	BBC	Big Chief .060"
65124103	BBC	Big Chief N ports .060"
65124201	BBC	Big Chief .120"
65124203	BBC	Big Chief N ports .120"
65128000	SBF	170cc and 195cc
65128100	SBF	CNC 210cc and 225cc

## EXHAUST GASKETS

PART NO.	ENGINE	DESCRIPTION
65211405	SBC	#1405 (SHP, Iron Eagle, PRO1)
65211406	SBC	#1406
65222000	SBC	18° Race Series
65226000	SBC	Little Chief 1.750"
65226200	SBC	Little Chief, LS1/LS3/LS7 and LS 10°
65221000	BBC	18° Race Series
65223000	BBC	Big Chief or BBC Full port
65224000	BBC	Standard port
65228000	SBF	170cc and 195cc
65228100	SBF	CNC 210cc and 225cc

## VALVE COVER GASKETS

PART NO.	ENGINE	DESCRIPTION
65311604	SBC	#1604
65321000	SBC	Standard
65321200	SBC	5/16 cork
65326000	SBC	Little Chief
65322000	BBC	18° .062"
65323000	BBC	Standard
65323200	BBC	5/16" cork
65324000	BBC	Big Chief
65326100	LS	.060" Paper
65326101	LS	.100" Steel Core

## PUSHROD GUIDE PLATES

PART NO.	ENGINE	DESCRIPTION
27001110	SBC	5/16" Flat
27001230	BBC	3/8" Adjustable
27001230-4	BBC	3/8" Adjustable (set of 4)
27001410	SBF/SBC	Adjustable

## ROCKER STUDS

PART NO.	ENGINE	DESCRIPTION
27002101	SBC/SBF	3/8"
27002102	SBC/SBF	7/16"
27002103	SBC	3/8" S/S
27002104	SBC	3/8" S/S set
27002204	BBC	Long exhaust rocker studs
27002223	BBC	Short intake rocker studs

## STUD GIRDLE PARTS

PART NO.	ENGINE	DESCRIPTION
64210210	BBC	7/16" intake, long stud girdle nut
64210220	BBC	7/16" exhaust, short stud girdle nut
64210230	SBC	3/8" SBC stud girdle nut

## HEAD STUD KITS

PART NO.	ENGINE	DESCRIPTION
66110012	SBC	18° 7/16" and 3/8" for Iron blocks
66110013	SBC	Little Chief 7/16" and 3/8" for Iron blocks
66110022	SBC	18° 7/16" and 3/8" for Aluminum blocks
66110023	SBC	Little Chief 7/16" and 3/8" for Aluminum blocks
66120011	SBC	Standard 7/16" for Iron blocks
66120012	SBC	18° 7/16" for Iron blocks
66120021	SBC	Standard 7/16" for Aluminum blocks
66120022	SBC	18° 7/16" for Aluminum blocks
66110014	SBC	12.5° & 13° 7/16 and 3/8" for Iron blocks
66110027	SBC	9° 4.4" bore space
66110027A	SBC	9° 4.5" bore space
66110017A	SBC	9° 4.5" bore space 7/16" and 3/8" for iron blocks
66120014	BBC	Standard 7/16" for Iron blocks (Old PRO1)
66120015	BBC	Big Chief 7/16" 12-pt for Iron blocks
66120024	BBC	7/16 12-pt for Aluminum blocks
66120025	BBC	Big Chief 7/16" 12-pt for Aluminum blocks
66130021	SBF	Dart PRO1 1/2" for Iron blocks
66130022	SBF	Yates HP 1/2" for Iron blocks
66130121	SBF	Dart PRO1 1/2" for Aluminum blocks
66130122	SBF	Yates HP 1/2" for Aluminum blocks
64210240	BBC	Inside head stud kit w/shoes
66120014-20	BBC	Dart PRO1 BBC & 20° for Iron blocks

BILLET

HON

SBF

BBC

LS

SBC

ACCESS

MANIFOLDS

HEADS

BLOCKS

TOP END KITS

SHORT BLOCKS

# ACCESSORIES & SERVICE PARTS

BILLET

HON

SBF

BBC

LS

SBC

ACCESS

MANIFOLDS

HEADS

BLOCKS

TOP END KITS

SHORT BLOCKS

## LS NEXT HEAD STUD KITS

PART NO.	ENGINE	DESCRIPTION
66120017	LS	7/16" 23 bolt 10° Race Series Iron LS Next Block
66120018	LS	7/16" 15 bolt Iron LS Next Block
66120018B	LS	7/16" 23 bolt (LS3/LS7) Iron LS Next Block
66130018	LS	1/2" 15 bolt Iron LS Next Block
66130018B	LS	1/2" 23 bolt (LS3/LS7) Iron LS Next Block
66120027	LS	7/16" 23 bolt 10° Race Series Aluminum LS Next Block
66120028	LS	7/16" 15 bolt Aluminum LS Next Block
66120028B	LS	7/16" 23 bolt (LS3/LS7) Aluminum LS Next Block
66130128	LS	1/2" 15 bolt Aluminum LS Next Block
66130128B	LS	1/2" 23 bolt (LS3/LS7) Aluminum LS Next Block

## HEAD STUDS

PART NO.	ENGINE	DESCRIPTION
66526000	BBC	Single 6" exhaust stud
66613550	Custom	7/16" and 3/8" x 3.550" for Aluminum blocks
66616100	Custom	7/16" and 3/8" x 6.100" for Aluminum blocks
66623400	Custom	7/16" x 3.400" for Aluminum blocks
66623750	Custom	7/16" x 3.750" for Aluminum blocks
66625150	Custom	7/16" x 5.150" for Aluminum blocks
66625450	Custom	7/16" x 5.450" for Aluminum blocks
66625650	Custom	7/16" x 5.650" for Aluminum blocks
66625800	Custom	7/16" x 5.800" for Aluminum blocks
66626050	Custom	7/16" x 6.050" for Aluminum blocks
66626250	Custom	7/16" x 6.250" for Aluminum blocks
66677000	Custom	7/16" x 7.000" for billet Aluminum blocks

## MAIN STUD KITS

PART NO.	ENGINE	DESCRIPTION
66311000	SBC	Standard for Iron Eagle blocks
66311110	SBC	SHP
66311400	SBC	Splayed for Little M blocks and SHP PRO
66321000	SBC	For Aluminum blocks w/ 10mm splay
66311300	BBC	Splayed, hex, for Big M Iron blocks
66311320	BBC	Splayed, for Big M Aluminum blocks
66311500	SBF	Splayed, 302, for Iron blocks (Iron Eagle)
66311600	SBF	Splayed, 351, for Iron blocks (Iron Eagle)
66311010	LS	Iron LS Next Block
66311011	LS	Iron LS SHP and SHP PRO
66311020	LS	Aluminum LS Next Block
66311510	SBF	302 SHP
66311610	SBF	351 SHP

## BOLT KITS

PART NO.	ENGINE	DESCRIPTION
66220011	SBC	Standard 7/16 head bolt for Iron blocks
66412200	SBC	7/16" for PRO1 top end kit
66220014	BBC	Standard 7/16" small hex head bolt Iron blocks
66422100	BBC	7/16 for Iron Eagle top end kit
66422200	BBC	7/16 for Iron Eagle or PRO1 top end kit

## BOLTS

PART NO.	ENGINE	DESCRIPTION
66424000	BBC	Head bolt, 7/16" - 14 x 4.210"
66426000	BBC	#6 exhaust bolt, 7/16" - 14 x 5.200"
66443500	BBC	Inverted valve cover bolt, 1/4" - 20 x 3.500"
66454375	BBC	6mm x 75mm factory 8.1 liter bolt
66440500	BBC	Ram top plate bolt 1/4" - 20 x 1/2" button head
66722000	SBC	Main bolt 3/8" x 2.000" 12-pt for Little M blocks
66722687	SBC	Main bolt 7/16" x 2.687" 6-pt for Little M blocks
66723200	SBC	Main bolt 7/16" x 3.200" small hex

## NUTS

PART NO.	ENGINE	DESCRIPTION
66810100	Custom	Cylinder head nut 3/8" - 24 12-pt
66820100	Custom	Cylinder head nut 7/16" - 20 12-pt
66830100	Custom	Cylinder head nut 1/2" - 20 12-pt
66820200	Custom	Cylinder head nut 7/16" - 20 6-pt
66830200	Custom	Cylinder head nut 1/2" - 20 6-pt

## WASHERS

PART NO.	ENGINE	DESCRIPTION
66910000	Custom	3/8" ground chamfer .625 OD
66910001	Custom	3/8" ground .750 OD
66920000	Custom	7/16" ground .810 OD
66921000	Custom	7/16" ground .700 OD (BCII & LC)
66925000	Custom	7/16" ID x .875 OD insert washer (used for Dart heads on stock Ford 8.2 blocks)
66930000	Custom	1/2" ground .870 OD



# ACCESSORIES & SERVICE PARTS

## STAINLESS STEEL INTAKE VALVES

PART NO.	ENGINE	DESCRIPTION	O.S.
21311940	SBC	1.940" x 11/32" (Iron Eagle S/S, Vortec)	No
21312020	SBC	2.020" x 11/32" (SHP, IE, PRO1 - 180, 200)	No
21312050	SBC	2.055" x 11/32"	No
21312080	SBC	2.080" x 11/32"	No
21322020	SBC	2.020" x 11/32"	+1.100"
21322055	SBC	2.055" x 11/32"	+1.100"
21322080	SBC	2.080" x 11/32"	+1.100"
21322100	SBC	2.100" x 11/32"	+1.100"
21332080	SBC	2.080" x 11/32"	+2.200"
21332100	SBC	2.100" x 11/32"	+2.200"
21362125	SBC	2.125" x 11/32" (Race Series 12.5° - 18°)	+6.600"
21362150	SBC	2.150" x 11/32" (Race Series 12.5° - 18°)	+6.600"
21362180	SBC	2.180" x 11/32" (Race Series 12.5° - 18°)	+6.600"
21362200	SBC	2.200" x 11/32" (Race Series 12.5° - 18°)	+6.600"
21392020	LS1	2.020" x 8mm	No
21392055	LS1	2.055" x 8mm	No
21392080	LS1	2.080" x 8mm	No
21392165	LS3	2.165" x 8mm	No
21392165H	LS3	2.165" x 8mm (Hollow Stem)	No
21397200	LS7	2.200" x 8mm	No
21342250	BBC	2.250" x 11/32" (IE 308 - PRO1 275, 325)	+2.250"
21342300	BBC	2.300" x 11/32" (IE 345 - PRO1 310, 355)	+2.250"
21342325	BBC	2.325" x 11/32"	+2.250"
21612250	BBC	2.250" x 3/8"	+2.250"
21642190	BBC	2.190" x 3/8" (PRO1 275, 310)	+2.250"
21642300	BBC	2.300" x 3/8" (PRO1 325, 345)	+2.250"
21382350	BBC	2.350" x 11/32" (Big M)	+3.350"
21372400	Big Chief	2.400" x 11/32"	No
21510034	Honda	34mm x 5.5mm	No

## STAINLESS STEEL EXHAUST VALVES

PART NO.	ENGINE	DESCRIPTION	O.S.
21311500	SBC	1.500" x 11/32" (Iron Eagle S/S, Vortec)	No
21311600	SBC	1.600" x 11/32" (SHP, Iron Eagle, PRO1)	No
21311625	SBC	1.625" x 11/32" (IE, PRO1 230 - CNC 227)	No
21321600	SBC	1.600" x 11/32" (PRO1 180, 230 - CNC 227)	+1.100"
21361600	SBC	1.600" x 11/32" (Race Series 12.5° - 18°)	+6.600"
21361625	SBC	1.625" x 11/32" (Race Series 12.5° - 18°)	+6.600"
21391600	LS1/LS3	1.600" x 8mm	No
21397625	LS7	1.625" x 8mm	No
21311880	BBC	1.880" x 11/32" (Iron Eagle, PRO1)	No
21321880	BBC	1.880" x 11/32" (Iron Eagle, PRO1)	+1.100"
21611880	BBC	1.880" x 3/8" (Iron Eagle, PRO1)	No
21311900	BBC	1.900" x 11/32" (Iron Eagle, PRO1)	No
21311840	BBC 18°	1.840" x 11/32"	No
21371900	Big Chief	1.900" x 11/32"	No
21510028	Honda	28mm x 5.5mm	No



BILLET

HON

SBF

BBC

LS

SBC

ACCESS

MANIFOLDS

HEADS

BLOCKS

TOP END KITS

SHORT BLOCKS

# ACCESSORIES & SERVICE PARTS

## TITANIUM INTAKE VALVES

PART NO.	ENGINE	DESCRIPTION	O.S.
21432100	SBC	2.100" x 11/32" (Race Series 220)	+ .200"
21432125	SBC	2.125" x 11/32" (Race Series 220)	+ .200"
21431625	SBC	1.625" x 11/32" (Race Series 220)	+ .200"
21462100	SBC	2.100" x 11/32" (Race Series 12.5° - 18°)	+ .600"
21462125	SBC	2.125" x 11/32" (Race Series 12.5° - 18°)	+ .600"
21462150	SBC	2.150" x 11/32" (Race Series 12.5° - 18°)	+ .600"
21462150S	SBC	2.150" x 5/16" (Race Series 12.5° - 18°)	+ .600"
21462180	SBC	2.180" x 11/32" (Race Series 12.5° - 18°)	+ .600"
21492180	Little Chief	2.180" x 5/16" (6.00", bead-loc)	No
21492230	Little Chief	2.230" x 11/32" (6.00", bead-loc)	No
21442300	BBC	2.300" x 11/32" (IE345 - PRO1 310, 355)	+ .250"
21482350	BBC	2.350" x 11/32" (Big M)	+ .350"
21472400	Big Chief	2.400" x 11/32"	No
21472470	Big Chief	2.470" x 11/32"	No
21472470S	Big Chief	2.470" x 5/16"	No
21472500	Big Chief	2.500" x 11/32"	No

## TITANIUM EXHAUST VALVES

PART NO.	ENGINE	DESCRIPTION	O.S.
21461600	SBC	1.600" x 11/32" (Race Series 12.5° - 18°)	+ .600"
21461625	SBC	1.625" x 11/32"	+ .600"
21491550	Little Chief	1.550" x 11/32" (5.750", bead-loc)	No
21491550S	Little Chief	1.550" x 5/16" (5.750", bead-loc)	No
21411840	BBC 18°	1.840" x 11/32"	No
21411880	BBC	1.880" x 11/32" (Iron Eagle, PRO1)	No
21411900	BBC	1.900" x 11/32" (Iron Eagle, PRO1)	No
21431600	BBC	1.600" x 11/32" (Iron Eagle, PRO1)	No
21471800	Big Chief	1.800" x 11/32"	No
21471850	Big Chief	1.850" x 11/32"	No
21471900	Big Chief	1.900" x 11/32"	No

## INCONEL EXHAUST VALVES

PART NO.	ENGINE	DESCRIPTION	O.S.
21811840	BBC	1.840" x 11/32" (Race Series 18°)	No
21811880	BBC	1.890" x 3/8" (Iron Eagle, PRO1)	No
21811890	BBC	1.890" x 11/32" (Iron Eagle, PRO1)	No
21811900	BBC	1.900" x 3/8" (Iron Eagle, PRO1)	No

## LASH CAPS

PART NO.	DESCRIPTION
29000001	5/16" (Set of 16)
29000002	11/32" (Set of 16)
29000003	3/8" (Set of 16)

## VALVE LOCKS

PART NO.	DESCRIPTION
24000021	11/32", 10 degree Pair
24000022	11/32", 10 degree +.050 Pair
24000023	11/32", 10 degree -.050 Pair
24000031	3/8", 10 degree Pair
24000121	11/32", 7 degree (1.250 valve spring only) Pair
24000151	8mm, LS1 Pair

## VALVE SPRINGS

PART NO.	DESCRIPTION
22000002	1.625" dual Hi-Tech w/o damper (1024)
22000002i	1.625" dual #9685
22000001	1.625" single Vasco Jet
22000004	1.700" triple short (1047)
22000005	1.700" triple tall (1048)
22000010	1.250" single
22000011	1.290" LS1 single beehive
22000111	1.295" LS1 dual
22000120	1.310" OD .665" ID LS7 solid dual
22000020	1.437" dual
22000030	1.550" BBC single outer
22000040	1.550" SBC tall
22000050	1.550" dual BBC
22000050H	1.550" hydraulic roller HD solid dual
22000060	1.550" #9365
22000070	1.560" #9385
22000080	1.550" Pacaloy tall dual
22000200	Honda 1.134" OD x .838" ID dual

## VALVE SPRING RETAINERS

PART NO.	DESCRIPTION
25000111	1.250" steel
25000112	1.437", 10 degree
25000113	1.550", 10 degree
25000212	1.437" Titanium dual
25000213	1.550" Titanium dual
25000214	1.625" Titanium dual
25000215	1.625" Titanium triple
25000216	1.290" 14 degree LS1/LS3/LS7
25000217	1.295" 14 degree dual LS1/LS3/LS7
25000218	1.310" 14 degree dual LS1/LS3/LS7

## VALVE SEALS

PART NO.	DESCRIPTION
26000010	PC Seal .311" x .415" Pro Stock
26000011	PC Seal .311" x .531"
26000012	PC Seal .311" x .500" (LS Dual Spring)
26000021	PC Seal .341" x .530"
26000022	PC Seal .341" x .500"
26000023	Rubber Seal, Umbrella S/S head
26000025	PC Seal S/S Head
26000031	PC Seal .371" x .530"
26000051	PC Seal .287" x .490" (LS Single Spring)

## VALVE SPRING CUPS

PART NO.	DESCRIPTION
23100002	1.690" x 1.550" x .060"
23100003	1.740" x 1.625" x .035"
23100004	1.740" x 1.655" x .060"
23100005	1.740" x 1.550" x .060"
23100006	1.740" x 1.550" x .150"

# ACCESSORIES & SERVICE PARTS

## VALVE SPRING LOCATORS

PART NO.	DESCRIPTION
23200200	1.625"D x .060" - 15°, 16° & 18°
23200050	1.550"x.690"x.060" - 1.437" spring, 1.487" OD
23200100	1.550"x.730"x.060" - 1.487" OD
23200152	1.300"x.510"x.060" - LS 1.295" OD Dual

## VALVE SPRING SHIMS

PART NO.	DESCRIPTION
23300010	1.550" x .015"
23300020	1.550" x .030"
23300030	1.550" x .060"
23300040	1.625" x .015"
23300050	1.625" x .030"
23300060	1.625" x .060"
23300070	1.250" x .015"
23300080	1.250" x .030"
23300090	1.250" x .060"

## VALVE GUIDES

PART NO.	DESCRIPTION
63121101	1.950" - .502" - 5/16" MB
63121102	2.100" - .502" - 5/16" MB I
63121103	2.250" - .502" - 5/16" MB E
63121104	3.000" - .502" - 5/16" MB BC I
63121105	3.000" - .502" - 5/16" MB BC E
63121106	2.450" - .502" - 5/16" MB LC
63121201	1.950" - .502" - 11/32" MB
63121202	2.100" - .502" - 11/32" MB
63121203	2.250" - .502" - 11/32" MB
63121204	3.000" - .502" - 11/32" MB BC I Tapered
63121204II	2.825" - .502" - 11/32" MB BC II Tapered
63121205	3.000" - .502" - 11/32" MB BC E
63121206	2.450" - .502" - 11/32" MB LC
63121210	1.950" - .439" - 11/32" MB
63121213	2.250" - .439" - 11/32" MB
63121302	2.100" - .502" - 3/8" MB
63121303	2.250" - .502" - 3/8" MB
63121502	2.150" - .439" - 8mm MB LS1
63121603	2.250" - .502" - 7mm MB
63121613	2.250" - .439" - 7mm MB
63131201	BBC 11/32" .502" Steel
63131202	Big Chief .502" Steel
63121108	2.750" - .502" - 5/16" MB I E
63121208	2.750" - .502" - 11/32" MB I E

## VALVE GUIDE LINERS

PART NO.	DESCRIPTION
63210112	5/16" - 30 x 3.125"
63210122	5/16" - 60 x 3.125"
63210132	5/16" +.003" x 3.125"
63210211	11/32" x 2.400"
63210212	11/32" - 30 x 3.125"
63210213	11/32" - 30 x 3.875"
63210222	11/32" - 60 x 3.125"
63210232	11/32" +.003" x 3.125"
63210312	3/8" - 30 x 3.125"
63210322	3/8" - 60 x 3.125"
63210332	3/8" +.003" x 3.125"

## HEAD BOLT SLEEVES

PART NO.	DESCRIPTION
63300010	.500" x .014" x 2.800"
63300020	.500" x 12
63300030	.563" x 12
63300040	.625" x .014" x 2.600"
63300050	.656" x .014" x 2.800"

## VALVE SEATS

PART NO.	DESCRIPTION
VS2160	2.160" x 1.810" x .350" powder metal
VS2160BT	2.160" x 1.880" x .350" powder metal
VS2450	2.450" x 2.000" x .375" powder metal
VS2450BT	2.450" x 2.090" x .375" powder metal
VS2000	2.000" x 1.600" x .375" powder metal
VS1650	1.650" x 1.250" x .350" Iron Eagle standard, powder metal
VS1660	1.700" x 1.350" x .375" powder metal
VS2010	2.010" x 1.600" x .375" powder metal
VS2460	2.460" x 2.000" x .375" powder metal
VS2490	2.490" x 2.150" x .375" Iron
VS2520	2.520" x 2.150" x .375" Iron
VS1650BC	1.650" x 1.350" x .400" Copper BX material
VS2000BC	2.000" x 1.600" x .375" Copper BX material
VS2450BC	2.450" x 2.000" x .375" Copper B1 material
VS2520BC	2.520" x 2.200" x .375" Copper B1 material

\*Add an "I" to end of the part number to specify Ductile Iron instead of Powder Metal.

BILLET

HON

SBF

BBC

LS

SBC

ACCESS

MANIFOLDS

HEADS

BLOCKS

TOP END KITS

SHORT BLOCKS