



2018 SHOW SCHEDULE

AutoRama - Detroit	March 2-4	Detroit, MI
Goodguys All American Get-Together	March 24-25	Pleasanton, CA
Goodguys Meguiar's Del Mar Nationals	April 6-8	Del Mar, CA
Goodguys Nashville Nationals	May 11-12	Nashville, TN
Cruisin' Ocean City	May 17-20	Ocean City, MD
Goodguys Heartland Nationals	June 29-July 1	Des Moines, IA
Goodguys PPG Nationals	July 6-8	Columbus, OH
Corvettes at Carlisle	August 23-26	Carlisle, PA
Goodguys Colorado Nationals	Sept. 7-9	Loveland, CO
Holley LS Fest	Sept. 7-9	Bowling Green, KY
F-Body Beach Bash	October 11-13	Myrtle Beach, SC
Goodguys Southeastern Nationals	October 19-20	Concord, NC
SEMA	Oct. 30-Nov. 2	Las Vegas, NV
Goodguys Southwest Nationals	November 16-18	Scottsdale, AZ
PRI	December 6-8	Indianapolis, IN



GARAGE 2018 EVENT SCHEDULE

Goodguys Spring Lone Star Nationals	March 9-11	Fort Worth, TX
Goodguys All American Get-Together	March 24-25	Pleasanton, CA
Goodguys Meguiar's Del Mar Nationals	April 6-8	Del Mar, CA
The Mitty - Road Atlanta	April 27-29	Braselton, GA
Goodguys Nashville Nationals	May 11-12	Nashville, TN
SCCA CAM Texas	June 1-3	Mineral Wells, TX
Goodguys Heartland Nationals	June 29-July 1	Des Moines, IA
Goodguys PPG Nationals	July 6-8	Columbus, OH
Goodguys Colorado Nationals	Sept. 7-9	Loveland, CO
Holley LS Fest	Sept. 7-9	Bowling Green, KY
Goodguys Lone Star Nationals	Sept. 28-30	Fort Worth, TX
Goodguys Southeastern Nationals	October 19-20	Concord, NC
Goodguys Southwest Nationals	November 16-18	Scottsdale, AZ



AMERICAN MADE FOR AMERICAN MUSCLE

2018

First and foremost, thank you for your interest in Detroit Speed, Inc. We look forward to working with you and understanding your project, so we can help you build or update your dream car.

Detroit Speed was founded on the principle of building the passion for how to make a car perform at its peak, drive faster and handle better while allowing for modern ride qualities. Our goal is to understand the industry needs, and then design and build the best parts we know how to build to help you, the customer, transfer your American muscle car into a modern day ride. We sweat the details so you can simply enjoy the experience.

The Pro-Touring market is defined as a style of classic muscle car with enhanced suspension components, braking systems, drivetrain and aesthetics. These vehicles also have many of the amenities of a new performance car. This market has grown considerably in the last few years where people expect and want more from their vehicles. This continuous challenge of making cars better and more competitive, regardless of what year or what brand it is, that is what drives the team at Detroit Speed. We are continuing to work on new parts and improvements to our existing product lines while designing new parts for the up and coming generations of cars that are gaining all of our attention.



Cars are intended to be driven, whether that's on the street, race track or autocross course. Each owner has their own wants, interests, skill level and budget when it comes to their car upgrades or full-on build. We understand that and choose to offer different types of parts to fit each car and budget. Regardless of the suspension part or kit, ride quality, performance and stance are perfected through Detroit Speed's unique suspension geometry configurations.

Customer satisfaction is the key element to success. Building on a family-friendly, fun-loving classic car environment, we want you to be proud of your car, whatever you do with it, and we welcome the opportunity to be a part of your dream.

Thank you for continuing to drive this great industry forward.

Kyle Tucker
Owner/President



PARTNERS



We use, support and distribute products for the following industry leaders:



Detroit Speed is proud to be a member of these industry organizations:



TABLE OF CONTENTS

Why Detroit Speed?	4-5	Delete & Fill Plates	27
New Products for 2018	6-7	Shocks & Springs	28-29
Hydroformed Subframes	8-9	Speed-LIGN & Caster / Camber Plate Kit	30
QUADRALink™	10-11	SWIVEL-LINK™	31
Chevy II Front Frame & Fenders	12-13	Selecta-Speed™ Wiper Kit	32
Subframe Connectors	14	Headlight Kits	33
Mustang Alumina-Frame	15	Steering Gear & Rack	34
X-Gen Universal Front Suspension	16	Power Steering	35
X-Gen Universal QUADRALink™ Rear Suspension	17	Roll Cages	36
C2/C3 SpeedRay™ & DecaLink™ Kits	18-19	Headers	37
Front Suspension Speed Kits 1-3	20-21	Fuel Tanks	38
Rear Suspension Speed Kits 1-3	22-23	Axles	39
Mini-Tub Kits	24	Miscellaneous Product	40-41
Control Arms - Upper & Lower	25	Apparel / Accessories	42-43
Sway Bars	26		

WHY DETROIT SPEED?

Staying true to our core strengths, we manufacture upgraded aftermarket performance parts for American muscle cars, with a special emphasis on suspension and chassis upgrades. We offer full product lines for many GM, Ford and Mopar muscle cars to modernize the ride quality and handling performance of these great muscle cars.

We design all our products in-house and manufacture most of those parts in-house as well. Once designed, each part is tested by our drivers on grueling road courses and autocross tracks to prove maximum performance. By proving maximum performance, we feel confident our product is top-of-the-line for any application.

We strive to support the American workforce and are proud to say most of our parts are manufactured in the USA. This includes all our hydroformed subframes, forgings, stampings and castings which continue to be made in Detroit, MI by vendors that have been with Detroit Speed since the beginning.

Detroit Speed has been in business for nearly 20 years. Our direction began and continues to come from the passion of making vehicles perform at their highest potential and sharing that passion with a community of people.

Tire technology really is the first driving factor. When you put on performance tires with today's technology, you suddenly need a much better suspension and vehicle dynamics package. Detroit Speed has done the research, design and testing to bring you the best part we know how to build that will give you the best ride quality and handling you can have with a Pro-Touring vehicle.



TESTIMONIALS

At Ringbrothers we have learned over the years that car building consists of a lot of trials and errors. When we find things that work, we continue to use them. This is why we use Detroit Speed products.

— Jim Ring
Co-founder of Ringbrothers



I have used Detroit Speed products for over 15 years now. Their products have revolutionized how to build a proper Pro-Touring vehicle. DSE parts are designed, tested and validated prior to a customer ever getting a part. Kyle Tucker's extreme focus on being the best shows through in his products, customer service, vehicles and championships.

I built my last 6 Camaros with Detroit Speed parts. I feel the chassis parts were an integral part of my ability to win the Optima Ultimate Street Car Challenge in 2010 and 2012. Both of those cars were First Gen Camaros and used the complete Hydroformed Subframe, QUADRAlink rear suspension and other Detroit Speed parts. Because of the development of the chassis, I was able to dial in the cars very quickly prior to each OUSCI event.

The ability of the chassis being track capable and street friendly is a great combination. I have used this chassis for very hard track and street miles, racking up hundreds of laps and thousands of miles without any issues. If you want the best parts for your project, and that are proven to withstand anything thrown at it, choose Detroit Speed for your build.

— Mark Stielow
General Motors



PHOTO BY:
MCGAFFIN
DIGITAL PHOTO

NEW PRODUCT FOR 2018

Detroit Speed, Inc. is proud to offer a new line of suspension product for Chevy Camaro enthusiasts! New for 2018, Detroit Speed introduces front and rear suspension for the newest generation, 2016+ Camaros.

FRONT SUSPENSION:

The Detroit Speed, Inc. 2016+ Camaro Front Coilover Conversion Kit provides bolt-on replacement aluminum strut assemblies that are fully adjustable. The adjustable spindle bracket allows ride height to be adjusted without affecting strut travel as well as easy spring changes. The ride height can also be fine-tuned with a coilover adjusting nut on the strut body.

The Detroit Speed strut can achieve more negative camber than the OEM strut. The upper strut mount is replaced with a precision spherical bearing to eliminate compliance and improve response. In addition, the upper mounting plates offer Speed-LIGN™ technology for quick, easy camber adjustments for track tuning.

030333 - Front Coilover Conversion Kit, Single Adjustable - 6th Gen Camaro
030333-D - Front Coilover Conversion Kit, Double Adjustable - 6th Gen Camaro



REAR SUSPENSION:

The Detroit Speed, Inc. 2016+ Camaro Rear Coilover Conversion Kit is a direct bolt-on assembly that completely replaces the OEM rear strut assembly. The kit uses a Detroit Speed/JRi all aluminum shock with "Detroit Tuned" valving. The kit allows ride height adjustment and easy rear spring changes.

042432 - Rear Coilover Conversion Kit, Single Adjustable - 6th Gen Camaro
042432-D - Rear Coilover Conversion Kit, Double Adjustable - 6th Gen Camaro

FEATURES:

- Bolt-on design
- Available in single or double adjustable shocks
- Can lower the vehicle by up to 1.5" below stock ride height

RIDE HEIGHT BEFORE



RIDE HEIGHT AFTER



ADDITIONAL PRODUCT OFFERING FOR 6TH GEN

REAR COILOVER TOWER BRACE KIT:

The Detroit Speed, Inc. 2016+ Camaro Rear Coilover Tower Brace Kit is a bolt-in design that increases overall vehicle stiffness. It is made of lightweight aluminum with a black anodized finish included on both the brace and installation hardware. Detroit Speed recommends using this kit when switching over to a coilover suspension.

042433 - Rear Coilover Tower Brace Kit
6th Gen Camaro



HYDROFORMED SUBFRAMES

Detroit Speed's Front Hydroformed Subframe is a prime example of the quality and engineering efforts that go into all the parts manufactured by the company. As the only subframe in the aftermarket industry with hydroformed frame rails, this subframe blends the benefits of current OEM technology and aftermarket performance into one product.

This front subframe is a bolt-in replacement for the original stock subframe, featuring stamped main and secondary crossmembers for structural rigidity. Using Detroit Speed's unique suspension geometry, you will experience improved handling and ride quality both on the road and on the track.

Sold in bare metal, uncoated and unassembled as standard. Upgrades are available for assembly and a powder coated finish.

SUBFRAME COMES COMPLETE WITH THE FOLLOWING COMPONENTS:

- Hydroformed frame rails
- OEM-quality stamped crossmembers
- TIG-welded tubular upper and lower control arms
- Detroit Speed/JRi aluminum body coilover shocks with 'Detroit Tuned' valving*
- Coilover springs
- 'Detroit Tuned' power rack and pinion steering
- Integrated splined sway bar with composite bushings
- Control arm cross shafts with caster tuner bushings
- Forged aluminum Detroit Speed spindles

*DETROIT SPEED/JRI SHOCK UPGRADES AVAILABLE.



FRONT HYDROFORMED SUBFRAME SPECIFICATIONS:

Total Suspension Travel	6"
Flange-to-Flange Distance (without rotors)	59.4"
Flange-to-Flange Distance (with Baer rotors)	60.0"
Ride Height*	2.9" ± 1.0"
Static Camber	-0.5° ± 0.2°
Static Caster	+7.5° ± 0.5°
Static Toe	0.0° ± 0.1°
Spring Rate	550 or 650 lb/in
Spring Free Length	8"
Total Bump Steer, 30" Toe-Span	0.084" over 6" of travel

*Measured from the top of the frame rail to the center of the hub

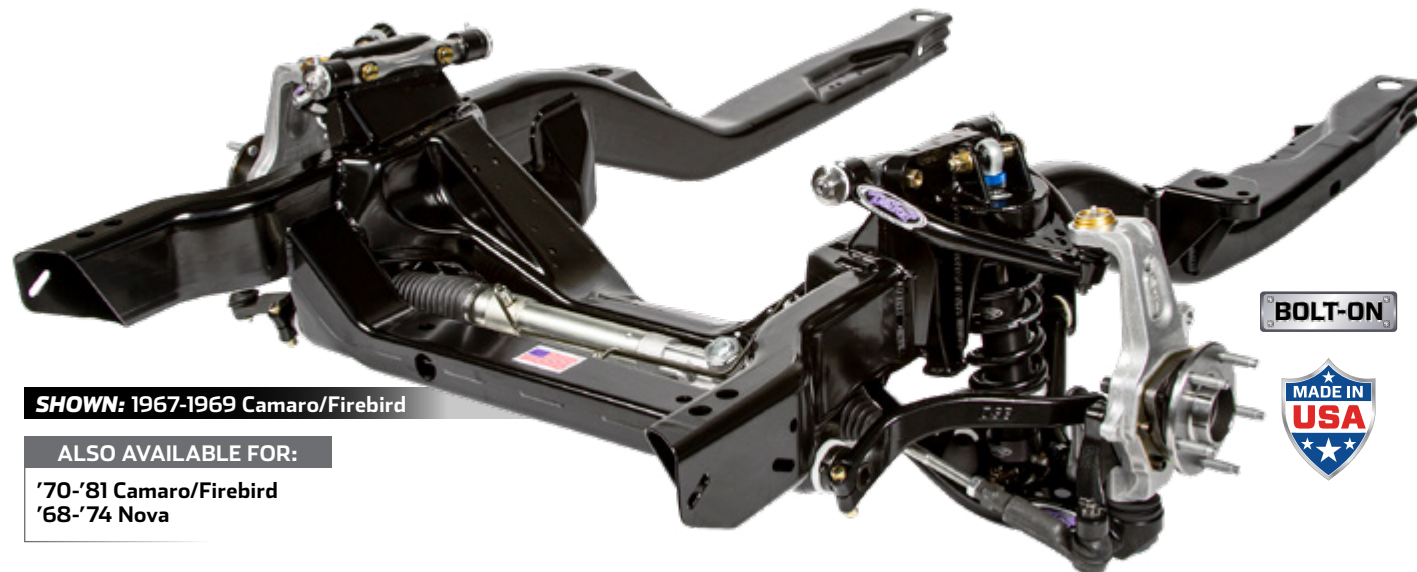
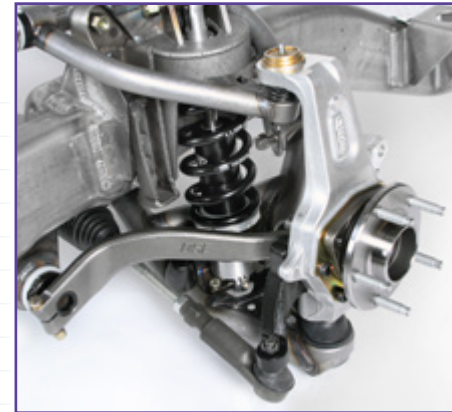

SHOWN: 1967-1969 Camaro/Firebird

ALSO AVAILABLE FOR:

'70-'81 Camaro/Firebird
'68-'74 Nova

BOLT-ON



WHY HYDROFORMING?

Hydroforming is a manufacturing process that preserves the steel's strength and stiffness because the process is performed at low temperatures and promotes uniform wall thickness unlike other fabricated frame rails.

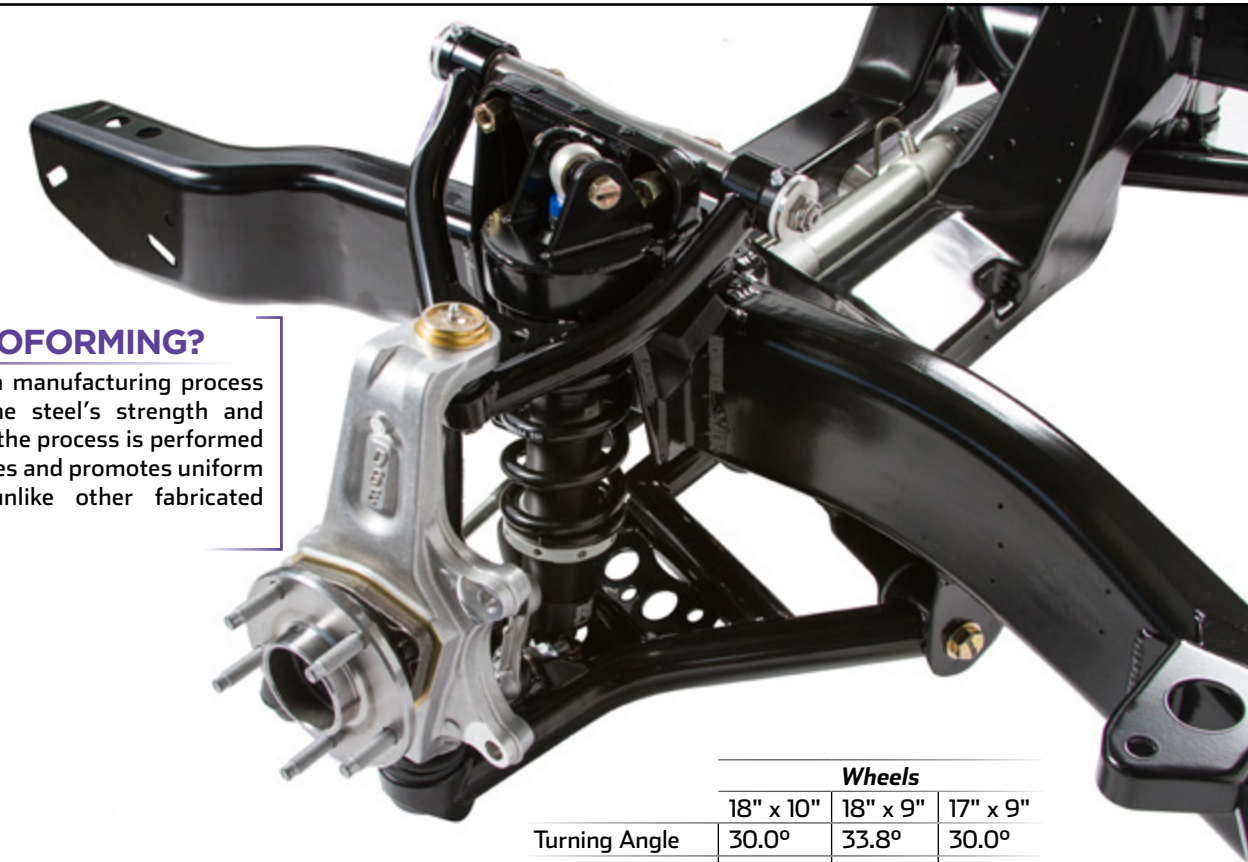

	Wheels		
	18" x 10"	18" x 9"	17" x 9"
Turning Angle	30.0°	33.8°	30.0°
Ackerman Angle	2.5°	3.5°	2.5°

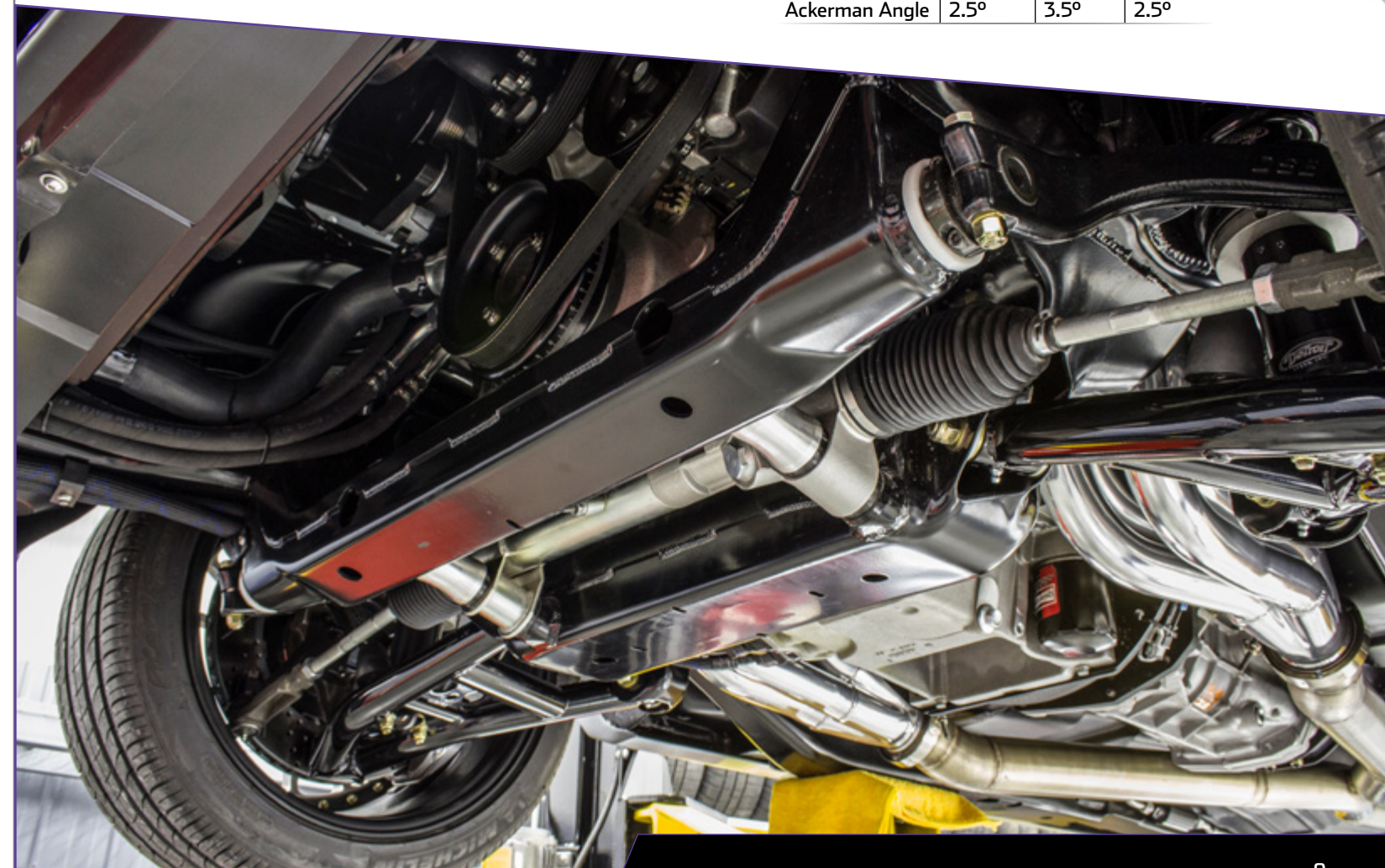

QUADRALink™

Detroit Speed's QUADRALink™ Rear Suspension Kit is strategically designed to offer the best possible ride quality and handling without compromising either. Featuring Detroit Speed's exclusive 4-link geometry, the QUADRALink kit is an upgrade to a car's stock original leaf spring suspension, allowing for more tuning capability.

Detroit Speed's patented SWIVEL-LINK™ technology eliminates binding and allows the suspension to fully articulate with smooth, solid motion without the use of noisy heim joints that wear out. Contrary to competitors' kits, this Detroit Speed kit utilizes a long Panhard rod that is adjustable as ride height changes. The QUADRALink kit is designed to work with either Detroit Speed mini-tubs or the stock tubs. The stock back seat can still be used.

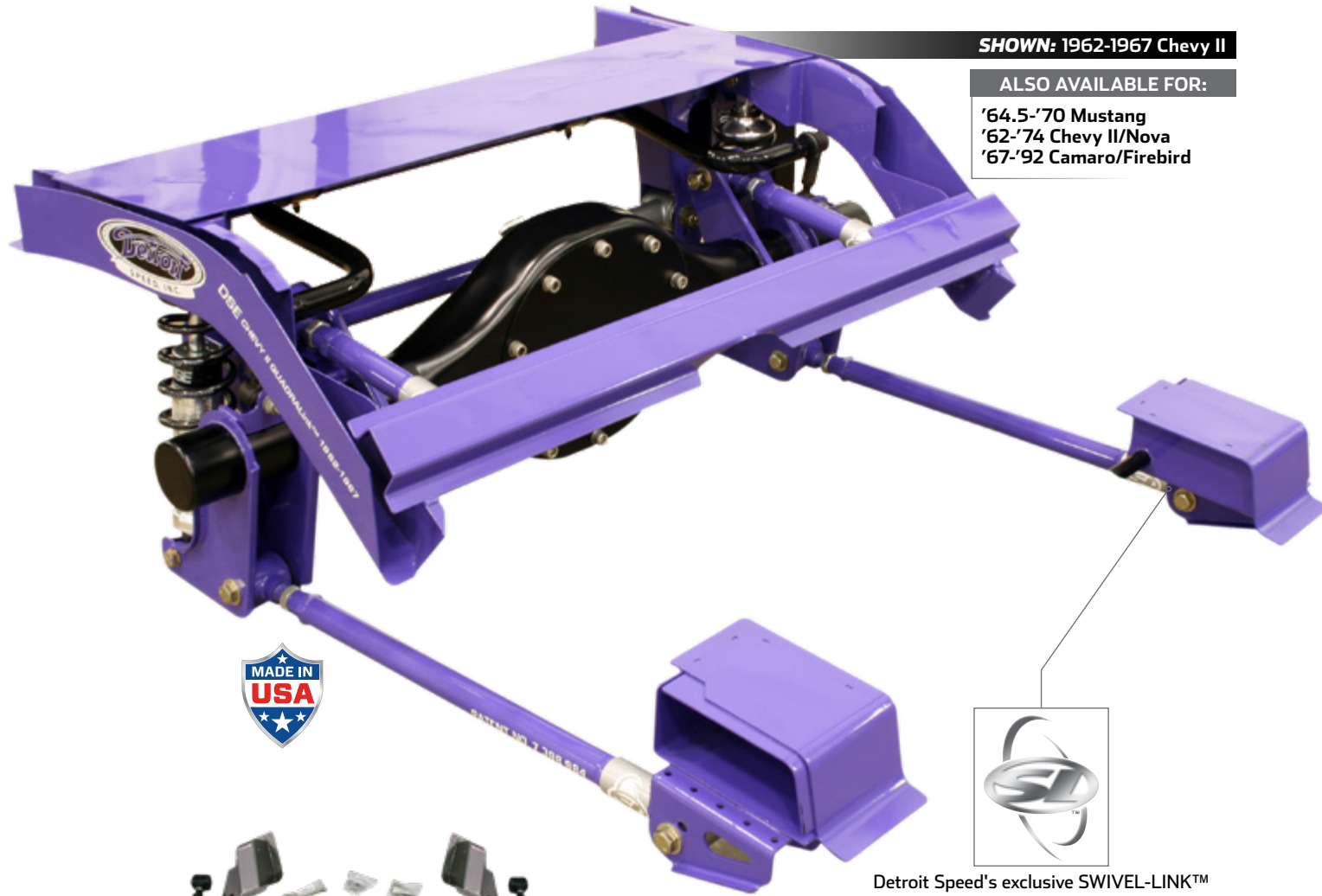

SHOWN: 1962-1967 Chevy II

ALSO AVAILABLE FOR:

- '64.5-'70 Mustang
- '62-'74 Chevy II/Nova
- '67-'92 Camaro/Firebird



Detroit Speed's exclusive SWIVEL-LINK™ (Patented) technology eliminates binding and allows the suspension to fully articulate without the use of noisy heim joints



1967-1969 Camaro/Firebird QUADRALink™ Rear Suspension Kit

NOTE: Axle brackets require a 3" axle tube. Rear end housing not included.



QUADRALink™ installed in a 1967 Chevy II.

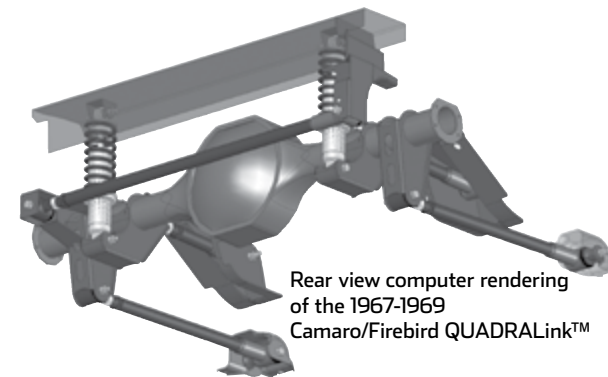

Rear view computer rendering of the 1967-1969 Camaro/Firebird QUADRALink™

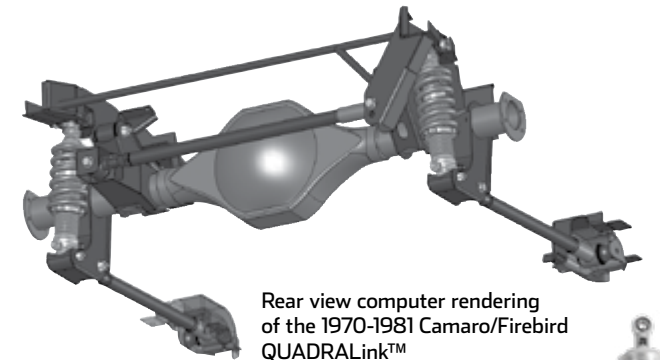

Rear view computer rendering of the 1970-1981 Camaro/Firebird QUADRALink™

QUADRALINK™ FEATURES:

- Detroit Speed patented, no-bind SWIVEL-LINK™ technology
- Detroit Speed/JRi aluminum body coilover shocks with 'Detroit Tuned' valving*
- Coilover springs
- Lower links are offset inboard for additional tire clearance
- All links are powder coated black

***DETROIT SPEED/JRI SHOCK UPGRADES AVAILABLE**
as well as anti-roll bar options, narrowed fuel tanks, tow hooks and custom GM 12-Bolt or Ford 9" rear end housings.



CHEVY II FRONT FRAME

Detroit Speed's Chevy II Front Frame was designed as a bolt-in replacement for the original stock suspension. It is the only Chevy II front frame in the aftermarket industry with OEM quality stamped crossmembers for improved structural rigidity.

Engineered to not just improve the structural integrity of the Chevy II front suspension, this kit utilizes Detroit Speed's unique suspension geometry to significantly improve the handling and ride quality, allowing your car to perform both on the street and on the track. The downbars feature rigid, integral hood hinge mounts that are hidden when used with Detroit Speed's Chevy II inner fenders.

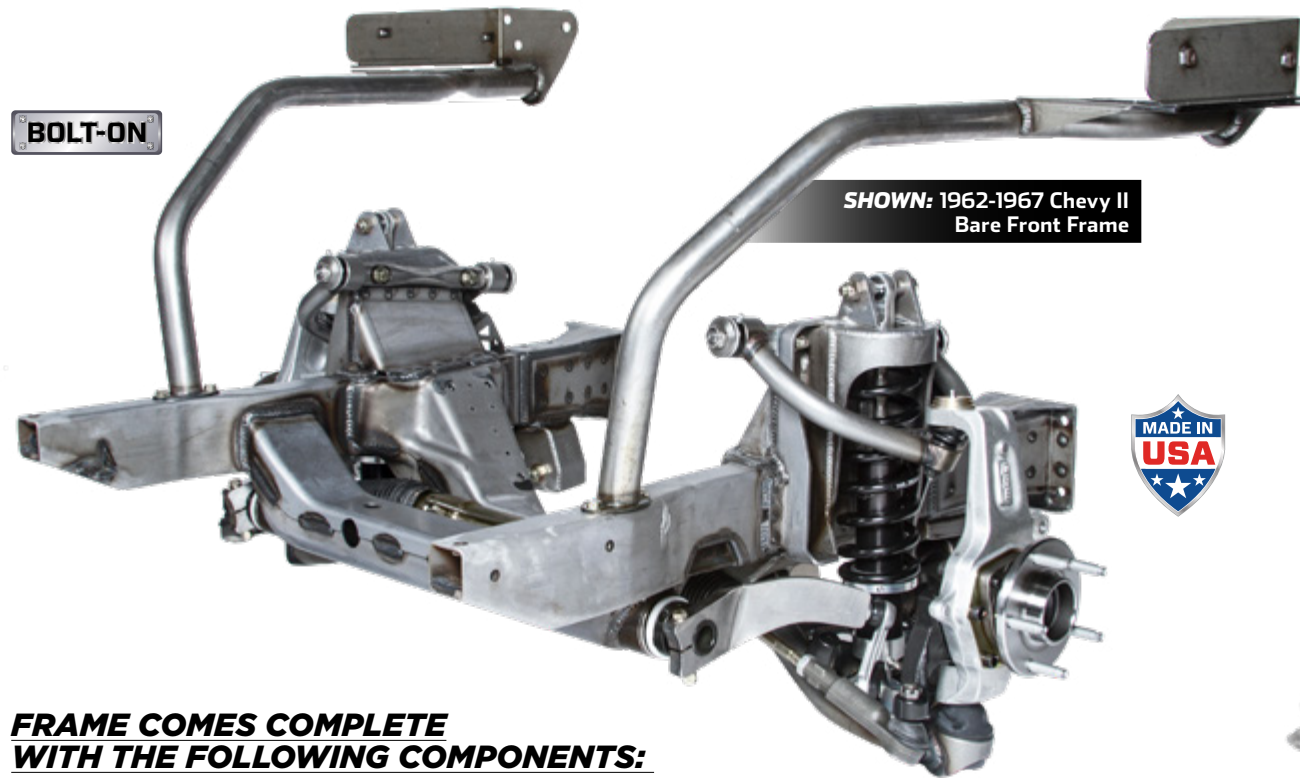

FRAME COMES COMPLETE WITH THE FOLLOWING COMPONENTS:

- TIG-welded tubular upper and lower control arms
- OEM-quality stamped crossmembers
- Detroit Speed/JRi aluminum body coilover shocks with 'Detroit Tuned' valving*
- Coilover springs
- 'Detroit Tuned' power rack and pinion steering
- Integrated splined sway bar and composite bushings
- Control arm cross shafts with caster tuner bushings
- Forged aluminum Detroit Speed spindles

*DETROIT SPEED/JRi SHOCK UPGRADES AVAILABLE.



CHEVY II FRAME SPECIFICATIONS:

Total Suspension Travel	6"
Flange-to-Flange Distance (without rotors)	53.4"
Flange-to-Flange Distance (with Baer rotors)	54.0"
Ride Height*	1.5" ± 1.0"
Static Camber	-0.5° ± 0.2°
Static Caster	+7.0° ± 0.5°
Static Toe	0.0° ± 0.1°
Turning Angle	30.5°
Ackerman Angle	2.7°
Spring Rate	400lb/in
Spring Free Length	10"
Total Bump Steer, 28" Toe-Span	0.49"

*Measured from the top of the frame rail to the center of the hub



CHEVY II FRONT FRAME INNER FENDERS

Detroit Speed's Chevy II Front Inner Fenders are made from stamped steel. They are designed to fit Chevy II's equipped with a Detroit Speed Chevy II front frame. They will completely hide the front frame downbars, resulting in a neat and clean underhood appearance.



SUBFRAME CONNECTORS

These uniquely designed Detroit Speed weld-in subframe connectors increase your car's stiffness by connecting the front subframe to the rear frame rails. Laser cut brackets are included that attach the rear of the subframe to the connector for an easy, strong and simple welded joint.

Unlike competitor kits, the Detroit Speed subframe connectors are barely visible from underneath the car giving you the maximum amount of ground clearance. Additionally, the molded factory carpet will still fit over the subframe connectors.



SHOWN: 1967-1969 Camaro/Firebird Subframe Connectors



SHOWN: 1964.5-1970 Mustang Subframe Connectors



SHOWN: 1968-1974 Nova Subframe Connectors



SHOWN: 1962-1967 Chevy II Subframe Connectors

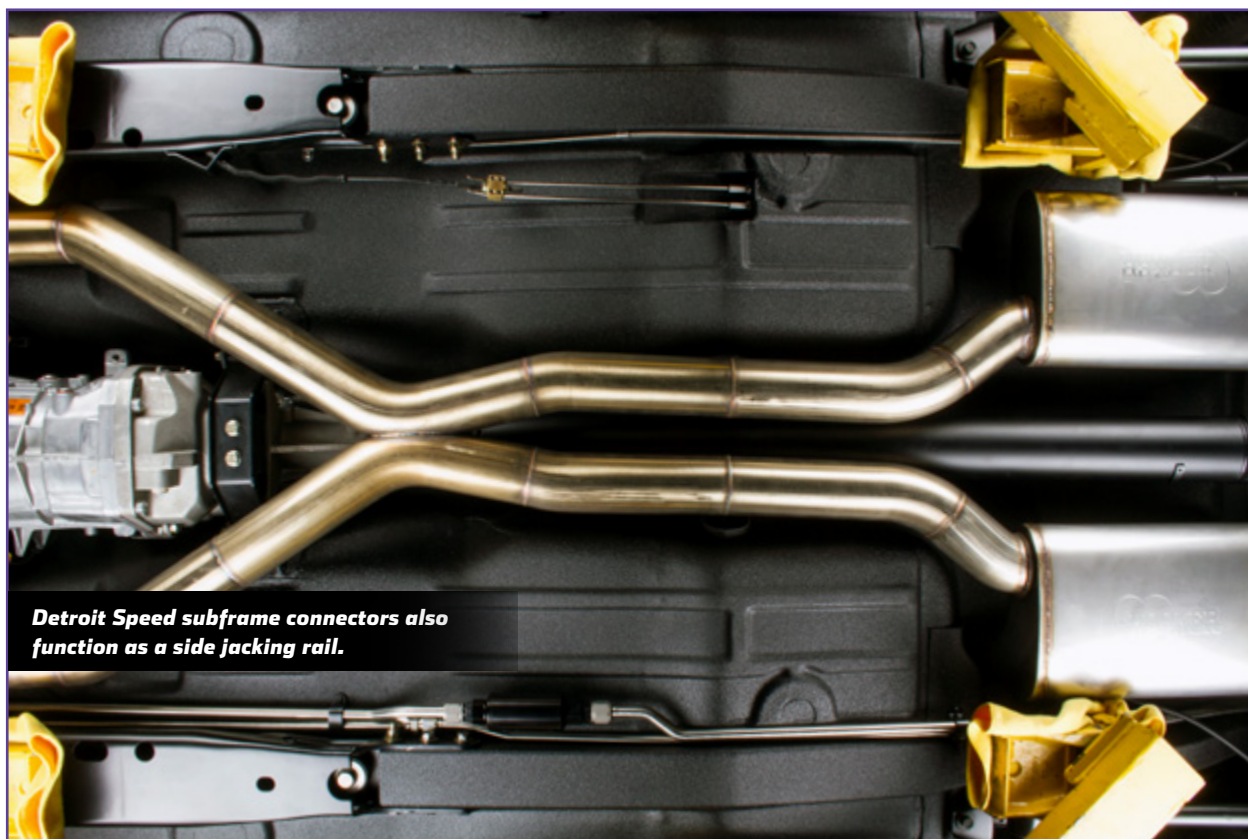

Detroit Speed subframe connectors also function as a side jacking rail.

MUSTANG ALUMA-FRAME

Detroit Speed's Mustang Aluma-Frame is an all-aluminum front suspension system for 1964.5-70 Mustangs that installs with the stock frame rails and inner fenders. It includes unique cast aluminum cradle and mounting components which result in a high strength-to-weight ratio and precise fitment. It also features Detroit Speed's *Speed-LIGN* caster/camber adjusters which allow for a wide range of adjustability to be made quickly.

The Aluma-Frame has Detroit Speed's unique suspension geometry with 6" of suspension travel for the ultimate in ride quality and performance both on the street and on the track.



MUSTANG ALUMA-FRAME FEATURES:

- Tubular upper and lower control arms
- Detroit Speed/JRi aluminum body coilover shocks with 'Detroit Tuned' valving*
- Coilover springs
- 'Detroit Tuned' power rack and pinion steering
- Integrated splined sway bar with composite bushings
- Forged aluminum Detroit Speed spindle and hub packs with a Ford or GM bolt pattern

*DETROIT SPEED/JRI SHOCK UPGRADES AVAILABLE.



MUSTANG ALUMA-FRAME SPECIFICATIONS:

Flange-to-Flange Distance (without rotors)	56.9"
Flange-to-Flange Distance (with Baer rotors)	57.7"
Total Suspension Travel	6"
Ride Height*	1.0" ± 1.0"
Static Camber	-0.5° ± 0.2°
Static Caster	+8.0° ± 0.5°
Static Toe	0.0° ± 0.1°
Total Bump Steer, 28" Toe-Span	0.070"
Turning Angle	27°
Ackerman Angle (at 15° turning angle)	0.875°
Spring Rate	400 lb/in
Spring Free Length	10"

*Measured up from the bottom of the frame rail to the center of the hub

NOTE: Minimal fabrication/welding required.



X-GEN UNIVERSAL FRONT SUSPENSION

Detroit Speed's X-Gen Series allows you to integrate Detroit Speed suspension technology into any vehicle for superior ride quality and handling. This complete suspension module is available with either a 53.5" or 59.5" track width and is ready to be subbed into your application with the 2" x 4" rail sections.

Featuring OEM-quality stamped crossmembers for improved structural rigidity, these are the same suspension systems found in Detroit Speed's bolt-in front frames. The X-Gen Series has been designed, engineered and developed to provide the ultimate in performance on both the road and the track.

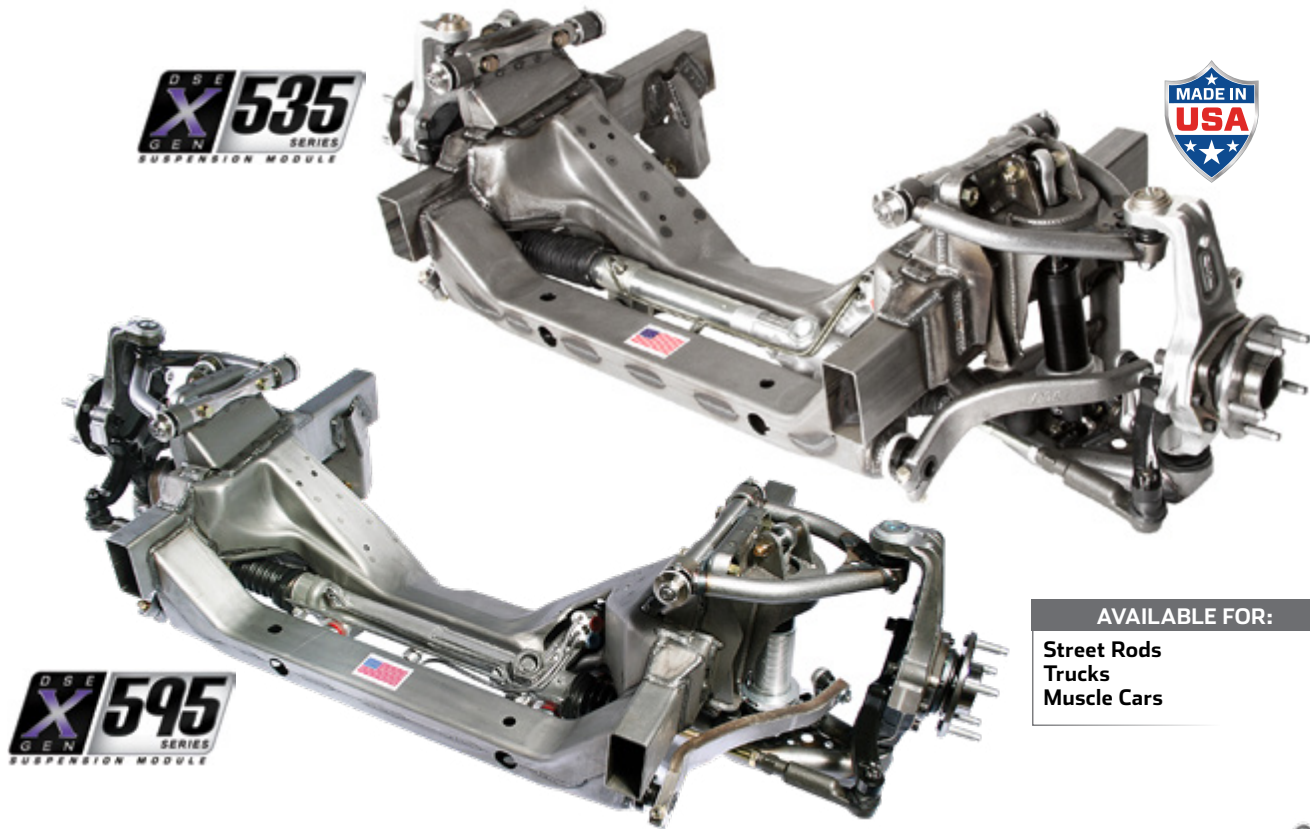

AVAILABLE FOR:
Street Rods
Trucks
Muscle Cars

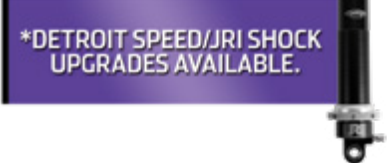

*DETROIT SPEED/JRI SHOCK UPGRADES AVAILABLE.

X-GEN SERIES FEATURES:

- OEM-quality stamped crossmembers
- TIG-welded tubular upper and lower control arms
- Detroit Speed/JRI aluminum body coilover shocks with 'Detroit Tuned' valving*
- Coilover springs
- 'Detroit Tuned' power rack and pinion steering
- Integrated splined sway bar with composite bushings
- Control arm cross shafts with caster tuner bushings
- Forged aluminum Detroit Speed spindles

	X-GEN 535 SPECIFICATIONS	X-GEN 595 SPECIFICATIONS
Track Width (Hub-to-Hub)	53.5"	59.5"
Maximum Wheel Backspacing	5"	6.125"
Total Suspension Travel	6"	6"
Frame Rail Dimensions	2" x 4" x 0.120" wall	2" x 4" x 0.120" wall
Outer-to-Outer Frame Width	30.5"	34.25"
Frame Rail Length	24.75"	25.25"
Distance from Rear of Frame Rail to Wheel Centerline	12.25"	13.188"
Nominal Ride Height*	1.5"	1.9"

*Measured up from the bottom of the frame rail to the center of the hub

NOTE: Minimal fabrication/welding required.

X-GEN UNIVERSAL QUADRALINK™ REAR SUSPENSION

Detroit Speed now offers a complementary rear suspension system for the X-Gen product line. Offered as either a non-staggered suspension system for a full-frame chassis, or staggered for uni-body vehicles, this system will fit nearly any vehicle.

Detroit Speed's exclusive 4-link geometry design is engineered to achieve the best possible handling during all conditions. The patented SWIVEL-LINK™ technology in combination with tuned high-durometer rubber bushings allows the suspension to fully articulate with smooth, silent motion. This system utilizes a horizontal track bar that provides precise and effective rear axle lateral location during hard cornering.



AVAILABLE FOR:
Street Rods
Trucks
Muscle Cars

X-GEN SERIES FEATURES:

- Detroit Speed patented, no-bind SWIVEL-LINK™ technology
- High-durometer rubber bushings, no heim joints to wear out and make noise
- Long Panhard rod for rear axle lateral control during hard cornering



SPEEDRAY™

The Detroit Speed SpeedRay™ Front Suspension is designed for the 1963-82 C2/C3 Corvettes. It utilizes exclusive Detroit Speed suspension geometry for superior handling and ride quality. It is available as a 100% bolt-on system or with a small amount of fabrication for a competition coilover option that allows for faster spring changes. The bolt-on powder coated front cradle assembly improves suspension geometry, provides rigid mounting for the rack and pinion, and includes integrated tie down eyelets. The body and engine do not need to be removed for installation of the SpeedRay front suspension.

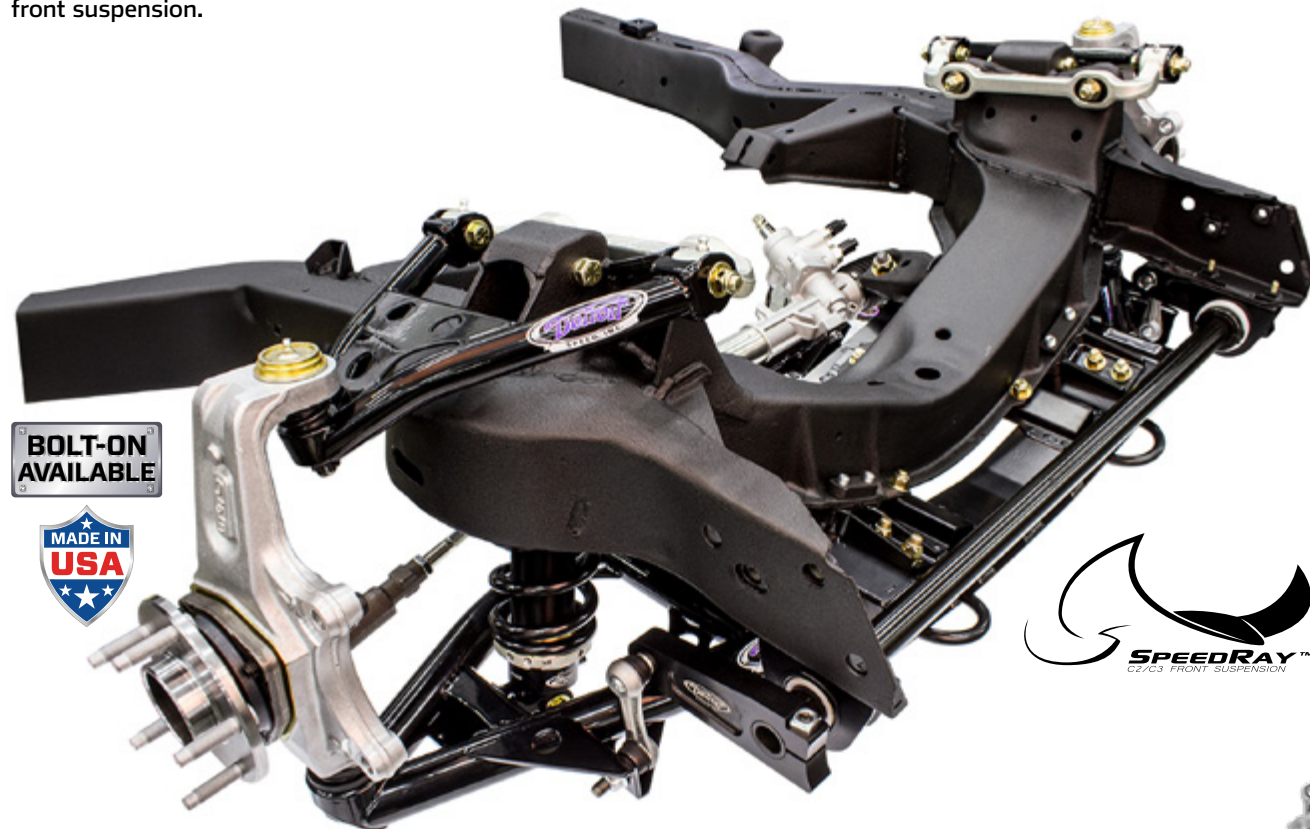

BOLT-ON AVAILABLE



SPEEDRAY™ FEATURES:

- TIG-welded tubular upper and lower control arms
- Detroit Speed/JRi aluminum body coilover shocks with 'Detroit Tuned' valving*
- Coilover springs
- 'Detroit Tuned' power rack and pinion steering
- Integrated splined sway bar with composite bushings
- Forged control arm cross shafts with caster tuner bushings
- Forged aluminum Detroit Speed spindles

*DETROIT SPEED/JRI SHOCK UPGRADES AVAILABLE.

SPEEDRAY™ FRONT SUSPENSION SPECIFICATIONS:

Total Suspension Travel	6"
Flange-to-Flange Distance (without rotors)	56.65"
Flange-to-Flange Distance (with Baer rotors)	57.25"
Ride Height*	7.6" ± 1.0"
Static Camber	-0.5° ± 0.2°
Static Caster	+7.5° ± 0.5°
Static Toe	0.0° ± 0.1°
Steering Ratio	13:1
Steering Wheel Turns Lock to Lock	2
Max Turning Angle (Outside wheel)	27.5°
Ackerman Angle (Full turn)	5.2°
Total Bump Steer, 20" Toe-Span	0.039"

*Measured from the bottom of Detroit Speed's front cradle to center of hub.



DECALink™

The Detroit Speed DECALink™ Independent Rear Suspension is designed for the 1963-82 C2/C3 Corvettes. It utilizes exclusive Detroit Speed suspension geometry for superior handling and ride quality. It features a cast aluminum/steel cradle assembly that is two pieces to ease differential housing removal. The DECALink IRS is designed to work with an original 17-spline differential assembly, or an available upgrade to either a 30-spline or a Hammerhead 12-bolt differential.

Included Detroit Speed/JRi 'Detroit Tuned' coilover shocks and springs allow for spring rate tuning and ride height adjustments. The kit includes a rear sway bar and uses OEM cross-axis pivot bushings at all pivot points. All suspension link lengths are adjustable, and the kit has adjustments for rear anti-squat geometry and roll center height.

No body modifications are required on 1968-79 models as the suspension is offset inboard for additional tire clearance.

DECALink™ FEATURES:

- Detroit Speed aluminum uprights forged in the USA
- Detroit Speed/JRi 'Detroit Tuned' coilover shocks*
- Coilover springs
- Rear sway bar
- Torrington bearings

*DETROIT SPEED/JRI SHOCK UPGRADES AVAILABLE.

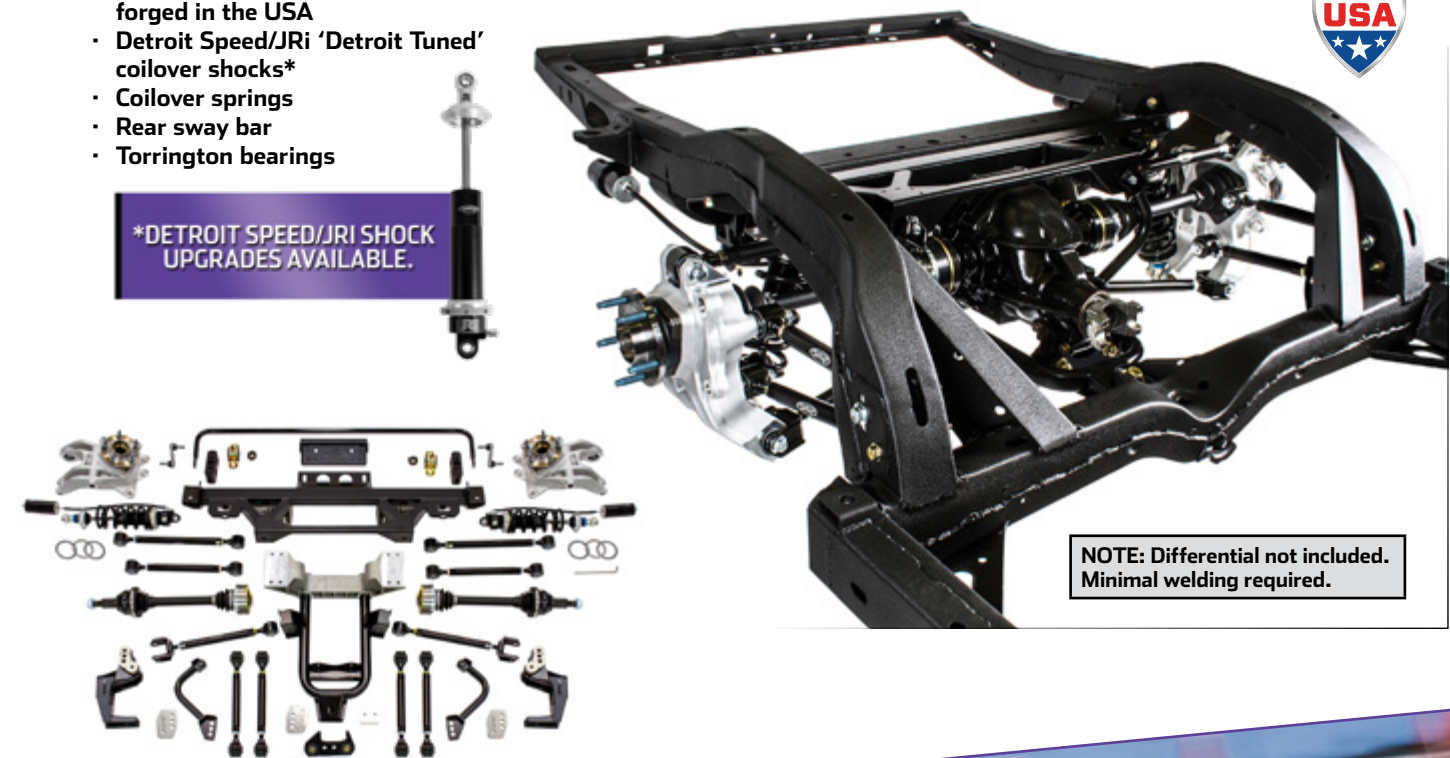

NOTE: Differential not included. Minimal welding required.



FRONT SUSPENSION SPEED KITS

Detroit Speed's exclusive Front Suspension Speed Kits combine our individual products into a system created specifically to give your vehicle a lowered ride height, without the cost of full-frame suspension upgrades. Each component in the kit was carefully designed to complement each other and to meet your driving needs. These Speed Kits will bring your classic muscle car into the 21st century with improvements in ride quality, handling and camber/caster correction.

Select kits are available for either small block, big block or LS engine applications.

Speed Kit Components	1967-81 Camaro/Firebird, 1968-74 Nova			1982-92 Camaro/Firebird			1978-88 Monte Carlo			1964-72 Chevelle			1973-77 Chevelle		
	SK1	SK2	SK3	SK1	SK2	SK3	SK1	SK2	SK3	SK1	SK2	SK3	SK1	SK2	SK3
Tubular Upper Control Arms	✓	✓	✓				✓	✓	✓	✓	✓	✓	✓	✓	✓
Tubular Lower Control Arms	✓	✓	✓	✓	✓	✓	✓	✓	✓	✓	✓	✓	✓	✓	✓
Drop Spindle										✓	✓	✓			
Koni Replacement Shocks	✓			✓	✓		✓			✓			✓		
Drop Springs	✓			✓			✓			✓			✓		
Tubular Sway Bar	✓	✓	✓	✓	✓	✓	✓	✓	✓	✓	✓		✓	✓	✓
Splined Sway Bar												✓			
Coilover Shocks		✓	✓				✓	✓		✓	✓		✓	✓	✓
Coilover Springs		✓	✓				✓	✓		✓	✓		✓	✓	✓
Strut Kit						✓									
Caster/Camber Plate Kit					✓										
Weight Jack Kit					✓	✓									
Chassis Braces							✓	✓	✓						
600 Power Steering Gear w/Rag Joint			✓						✓			✓			✓
Steering Service Kit			✓			✓			✓			✓			✓
Steering Shaft Kit						✓			✓			✓			✓

*Detroit Speed/JRi shock upgrades are available depending on application.



SPEED KIT 1

PROVIDES THE EASE OF BOLT-ON COMPONENTS TO IMPROVE YOUR VEHICLE'S HANDLING



BOLT-ON

SPEED KIT 2

TAKES THE HANDLING PERFORMANCE TO THE NEXT LEVEL AND OFFERS RIDE HEIGHT ADJUSTMENT

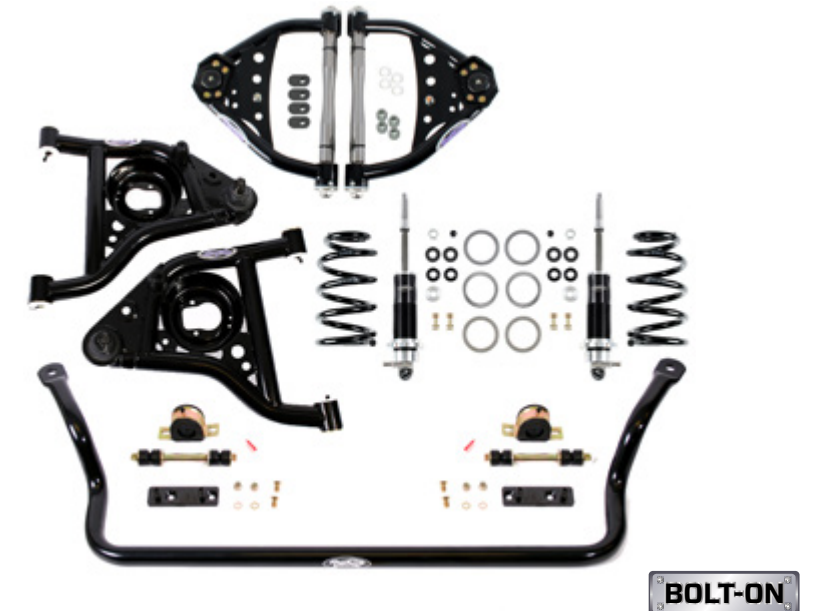

BOLT-ON

SPEED KIT 3

THE MOST ADVANCED HANDLING SYSTEM YOU CAN BUY, GIVING YOU THE ULTIMATE STEERING PERFORMANCE EXPERIENCED IN TODAY'S MODERN PERFORMANCE CARS

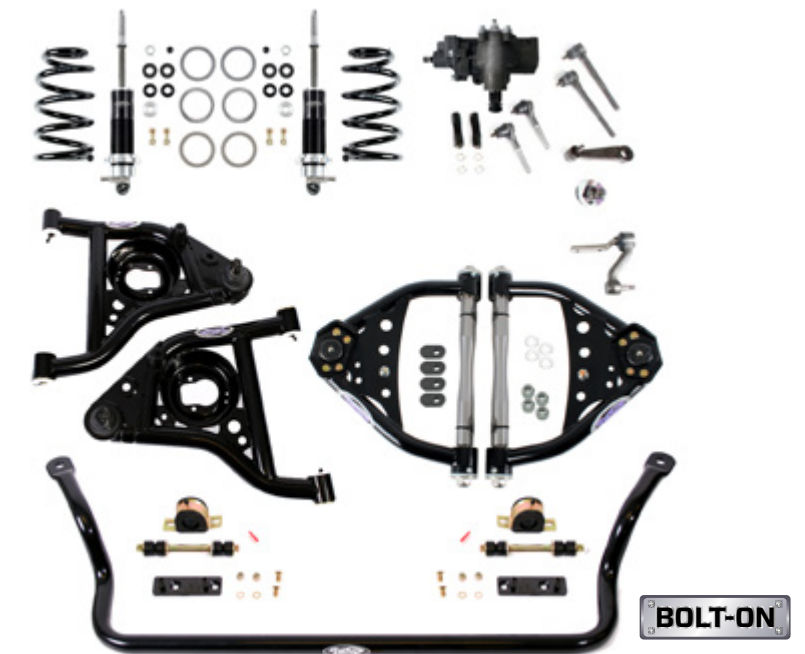

BOLT-ON

NOTE: Speed Kits shown for 2nd Gen Camaro. Other kits vary based on application.

All Speed Kit components can be purchased individually.

REAR SUSPENSION SPEED KITS

Detroit Speed's exclusive Rear Suspension Speed Kits combine our individual products into a system created to maintain optimum geometry and tire contact through the full range of rear suspension travel. Each Rear Speed Kit was designed to complement the Front Speed Kit for your specific vehicle, ensuring the ride quality and handling you experience is on-par with the latest modern muscle cars.

1967-81 CAMARO/FIREBIRD, 1968-74 NOVA:

Specific to 1967-81 Camaros and Firebirds, and 1968-74 Novas, the Detroit Speed rear leaf spring suspension kit improves handling due to the increased spring rate. It is available in either a 2" or 3" drop for a lower ride height and works great with any of our front suspension systems.

Speed Kit Components	1982-92 Camaro/Firebird			1978-88 Monte Carlo			1964-77 Chevelle		
	SK1	SK2	SK3	SK1	SK2	SK3	SK1	SK2	SK3
Koni Replacement Shocks	✓				✓			✓	
Drop Springs	✓				✓			✓	
Sway Bar	✓	✓	✓		✓	✓		✓	✓
Coilover Shocks		✓	✓			✓			✓
Coilover Springs		✓	✓			✓			✓
Track Bar		✓							
QUADRALink™ Conversion Kit			✓						
SWIVEL-LINK™ Control Arms		✓		✓	✓	✓	✓	✓	✓
Chassis Braces							✓	✓	✓

*Detroit Speed/JRi shock upgrades are available depending on application.

2010-15 CAMARO

Speed Kit Components	2010-11 Camaro			2012-15 Camaro		
	SK1	SK2	SK3	SK1	SK2	SK3
Front Drop Springs	✓			✓		
Rear Drop Springs	✓			✓		
Front Sway Bar End-Link Kit		✓	✓		✓	✓
Front Sway Bar	✓	✓	✓	✓	✓	✓
Rear Sway Bar End-Link Kit			✓		✓	✓
Rear Sway Bar	✓	✓	✓	✓	✓	✓
Single Adjustable Front Coilover Shocks		✓			✓	
Double Adjustable Front Coilover Shocks			✓			✓
Front Coilover Springs		✓	✓		✓	✓
Front Caster Kit		✓	✓		✓	✓
Rear Toe Link Kit		✓	✓		✓	✓
Single Adjustable Rear Coilover Shocks		✓			✓	
Double Adjustable Rear Coilover Shocks			✓			✓
Rear Coilover Springs		✓	✓		✓	✓
Rear Lower Control Arms			✓			✓
Rear Trailing Arm Kit			✓			✓
Solid Rear Cradle Mounts			✓			✓

SPEED KIT 1
 PROVIDES THE EASE OF BOLT-ON COMPONENTS TO IMPROVE YOUR VEHICLE'S HANDLING OVER STOCK CONDITIONS



BOLT-ON

SPEED KIT 2
 TAKES PERFORMANCE AND CORNERING TO THE NEXT LEVEL TO GIVE YOU MORE CONTROL

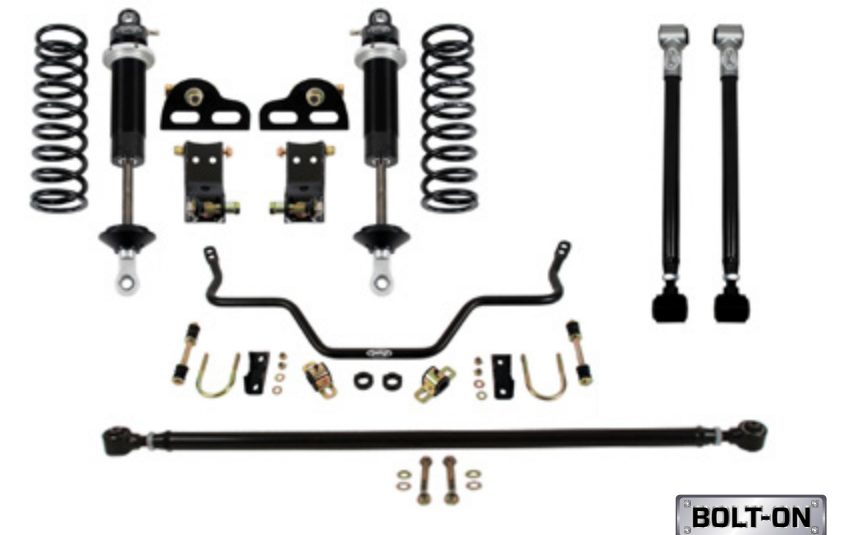

BOLT-ON

SPEED KIT 3
 THE MOST ADVANCED OF THE DETROIT SPEED KITS, INCLUDING UPGRADES FOR SHOCKS AND SPRINGS FOR MAXIMUM ADJUSTABILITY

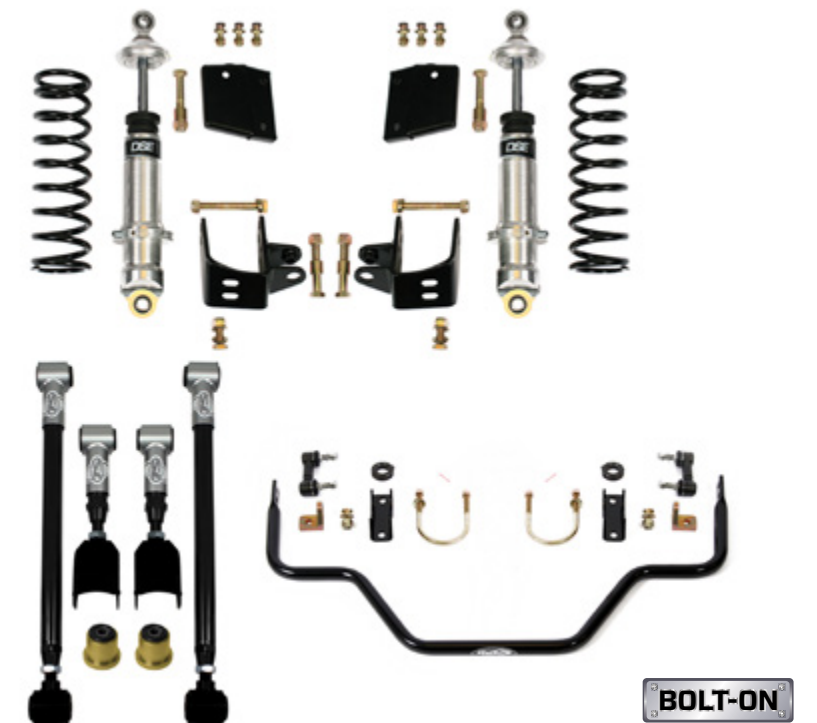

BOLT-ON

NOTE: SK1 & SK2 are for the 1982-92 Camaro/Firebird and SK3 is for 1978-88 Monte Carlo platforms. Other kits vary based on application.

All Speed Kit components can be purchased individually. Rear end housing is not included.

MINI-TUB KITS

Detroit Speed Mini-Tubs are inner wheel housings designed to accommodate a wider tire and wheel package. Stamped from 18-gauge steel, they are designed for a perfect fit on each specific application available to retain a stock appearance.

Mini-Tubs are available both individually, or as a complete kit which includes all necessary parts for a full project package.



SHOWN: 1964.5-1970 Mustang Mini-Tubs



REAR MINI-TUB KIT INCLUDES:

- Detroit Speed Mini-Tubs
- Rear upper shock crossmember
- Rear upper shock mounts
- Offset shackles
- Rear leaf springs
- Adjustable leaf spring pads*
- Lower shock plates
- U-bolts
- Urethane bushings
- Mini-Tub shocks

*3" Axle tubes required



SHOWN: 1967-1969 Camaro/Firebird Mini-Tub Kit

NOTE: A narrowed fuel tank is required for install of Detroit Speed mini-tubs.

TUBULAR UPPER & LOWER CONTROL ARMS

The unique Detroit Speed upper and lower tubular control arm kits are engineered as a bolt-on installation for improved suspension geometry over stock. Manufactured for various vehicle applications, both upper and lower control arms are TIG-welded in a fixture for accuracy and repeatability of suspension geometry. They are powder coated black for a clean finish.

The upper control arms provide increased strength and additional positive caster. They feature CNC-machined stainless-steel cross shafts which incorporate Detroit Speed caster tuner bushings, laser cut tube ends for a precise fit, and Delrin™ bushings.



SHOWN: 1970-1981 Camaro/Firebird Upper Control Arms



Side View

UPPER & LOWER CONTROL ARMS ALSO AVAILABLE FOR:

- 1967-81 Camaro/Firebird
- 1982-92 Camaro/Firebird (lower control arms only)
- 1968-74 Nova
- 1964-77 A-Body
- 1978-88 Monte Carlo/Regal

The lower control arms feature a robust tubular design with gussets and cross brace, Delrin™ bushings, laser cut tube ends and machined ball joint pockets for an exact fit. The geometry features include additional positive caster compared to stock.



SHOWN: 1970-1981 Camaro/Firebird Lower Control Arms



SHOWN: 1978-1988 Monte Carlo/Regal Lower Control Arms

NOTE: All parts included except grease. DRIVEN Oil grease available separately. Installation should be followed up by a professional alignment.

SWAY BARS

Improve cornering and reduce body roll with Detroit Speed's own larger diameter front and rear hollow sway bars. Detroit Speed engineers have designed these sway bars specific to each vehicle's application, providing you the best product offering available. Manufactured and tested in-house to control quality, our larger than stock bars are powder coated black and include everything you need to bolt it directly into your vehicle.

The Detroit Speed front splined sway bar kit is tuned to provide the ultimate in performance, ride quality and handling. These sway bars feature a direct bolt-in frame bracket that relocates it for better fitment and improved front frame stiffness.



Detroit Speed's rear sway bars offer more stability and minimize deflection as your car is placed under heavy cornering loads. These bars attach to the rear end housing and the chassis crossmember as opposed to the stock lower control arm mounted bar which stabilizes the rear axle. These bars mount to the chassis with a low-friction ball style end-link, allowing free articulation of the bar, eliminating binding through the range of rear suspension travel.



DELETE & FILL PLATES

The exclusive Detroit Speed firewall fill plate is an excellent way to smooth the firewall when installing an aftermarket air conditioning system such as Vintage Air. The stamped, weld-in panel is made of 18-gauge steel and has a rolled edge.



Detroit Speed offers multiple bolt-in heater or A/C delete plates depending on your vehicle application. These plates are made of 18-gauge steel and stamped with pride in the USA.

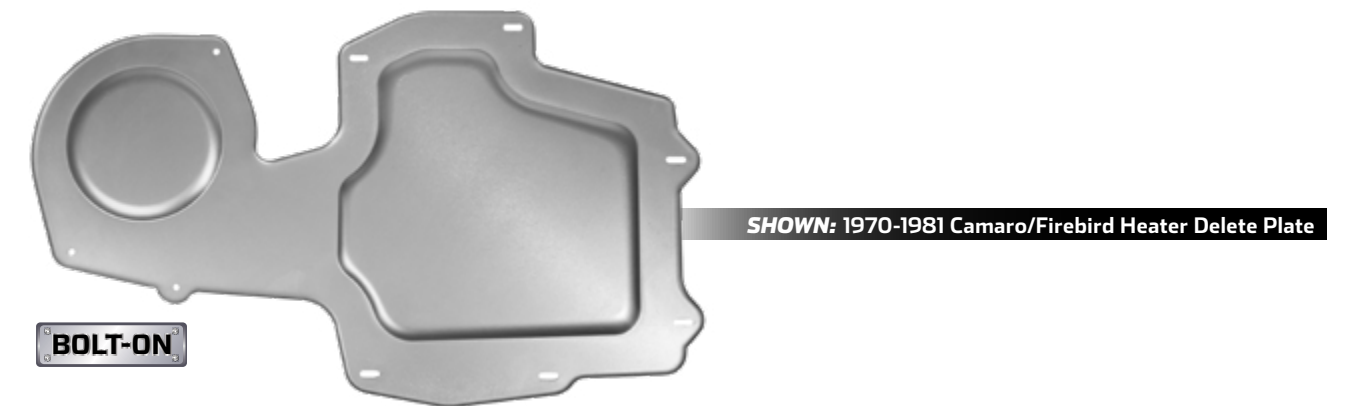

The shock tower delete plates for 1964.5-70 Mustangs are used to close out the stock inner fender panels after removing the original strut towers. They can be bolted or welded in place, are compatible with stock inner fender panels and are designed to mimic original strut towers for a modern appearance. Manufactured from 18-gauge stamped steel, the delete kit provides clearance for Ford Modular engines and most aftermarket suspension systems.



SHOCKS

Detroit Speed offers multiple shock options to replace your original, worn suspension depending on your driving preferences and budget. Our front and rear replacement shocks have been engineered to maximize ride comfort and handling performance. Featuring 'Detroit Tuned' valving in our adjustable shocks allows for a great deal of fine tuning range whether you are on the street or track. These are bolt-in shocks that provide modern shock absorber technology for early muscle cars.

Detroit Speed also offers front and rear coilover kits designed to convert your stock shocks and springs to a coilover shock and spring suspension system. This kit offers the latest in coilover spring/shock technology to be bolted into your vehicle and allows you to easily adjust the ride height and spring rate to suit your driving needs.

FRONT AND REAR COILOVER KITS INCLUDE:

- Coilover shocks and springs
- Torrington bearing set
- All necessary fasteners
- JRi spanner tool



SHOWN: 1964-1972 A-Body Front Coilover Conversion Kit

BOLT-ON



SHOWN: 1964-1972 A-Body Rear Coilover Conversion Kit



Detroit Speed chooses JRi for its shocks due to JRi's extensive history in the industry and various forms of racing. The JRi formula is to conduct a mass of research with high-tech equipment, utilize the most innovative minds in the game, mixed with science and engineering, feedback from testing, and input from real racers to provide the most advanced performance of any shock on the market. Detroit Speed believes in providing its customers with the most quality product on the market, so its partnership with JRi is a natural fit.

SPRINGS

Give your vehicle a modern Pro-Touring stance while improving ride and handling with Detroit Speed's front and rear coil springs. These springs are inspected in-house, printed with the spring rate, and will not lose their height over time.

FRONT COIL SPRINGS

OFFERED IN EITHER STOCK RIDE HEIGHT OR UP TO A 2" DROP (FROM STOCK) DEPENDING ON THE APPLICATION



REAR COIL SPRINGS

OFFERED IN EITHER A 1", 1.25"-1.5", 1.5" OR 2" DROP (FROM STOCK) DEPENDING ON THE APPLICATION



ORIGINAL STOCK SPRINGS



DETROIT SPEED 2" DROP SPRINGS



Speed-LIGN & CASTER/CAMBER PLATE KIT

The Detroit Speed Caster/Camber Plate Kit is a direct bolt-on kit that allows precise camber and caster adjustments at the strut tower. The caster/camber plate kit includes two plates, two strut retainers and new hardware. The camber and caster can be adjusted independent of each other and allows for increased adjustment range over stock.

The kit features *Speed-LIGN* technology that allows consistent and precise movements without any worry of unwanted shifting after the adjustment is made. The Detroit Speed *Speed-LIGN* adjustment device allows quick, accurate and repeatable adjustments to be made without needing any additional components. Adjustments are simply made by loosening the attaching fastener enough so the *Speed-LIGN* adjuster can be released from the notched frame and then moved to the desired notch position. Once the fastener is tightened, the *Speed-LIGN* adjuster locks the fastener into desired position in the slot.

KIT INCLUDES:

- Two caster/camber plates
- Two strut retainers
- New hardware

ALSO AVAILABLE FOR:

2010+ Camaros
1964-5-70 Mustangs (with Alumina-Frame)



SHOWN: 1982-1992 Camaro/Firebird

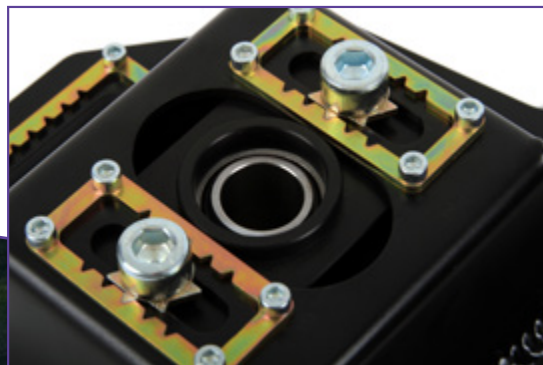

SWIVEL-LINK™

Detroit Speed's rear links incorporate our patented SWIVEL-LINK™ technology. Designed originally for the QUADRALink™ Rear Suspension System, this revolutionary product features an internal spindle that swivels on one end to allow the suspension to smoothly articulate, better keeping the rear tires planted while navigating the road or track. The SWIVEL-LINK eliminates binding and the use of noisy spherical rod ends.

The SWIVEL-LINK rear links allow for easy pinion angle adjustment for improved traction and lower driveline vibrations. They are powder coated satin black and the kit includes all new hardware.



SHOWN: 1964-1972 A-Body Rear SWIVEL-LINK™

SHOWN: 1982-1992 Camaro/Firebird SWIVEL-LINK™ Kit

BEHIND THE PATENTED DETROIT SPEED SWIVEL-LINK™

Detroit Speed is built on solid engineering. When setting out to create the ultimate in suspension components for GM F-Body, X-Body, A-Body, G-Body and early Ford Mustang vehicles, Detroit Speed had the opportunity to utilize the latest in technology, material, machining and assembly methods.

Seeing a deficiency in the leaf spring rear suspensions of the 1960's, Detroit Speed elected to take a clean sheet of paper and start over. We started with our unique geometry in a 4-link arrangement, utilizing coilovers and a Panhard bar. Rather than using existing approaches, Detroit Speed devised a system that eliminated noisy heim joints that can prematurely wear in a street driving environment.

Understanding that travel in a suspension should be smooth and fluid, there were several demands that needed to be satisfied to create the suspension we were after. If the parts were not available to accomplish the goal, we would invent our own.

Enter the creation of the SWIVEL-LINK™, the key component in the QUADRALink™ Rear Suspension System.

Utilizing a revolutionary internal spindle that swivels on one end the SWIVEL-LINK allows the suspension to smoothly articulate, better keeping the rear tires planted during spirited driving maneuvers. This sealed link has been through rigorous testing in the lab, street driving conditions, and on the track. As a bonus, the SWIVEL-LINK travels through its range of motion silently, making for a better quality driving experience.

The US Patent office thought the SWIVEL-LINK was a good idea as well, and on July 15th 2008, Detroit Speed was granted a US Patent as inventor of the SWIVEL-LINK.



Selecta-Speed™ WIPER KITS

A downpour of rain will no longer hinder your ability to clearly see the road. The Detroit Speed Selecta-Speed™ wiper kit provides you with the performance and convenience of a late model wiper system in a package that easily and cleanly mounts in your vehicle. The wiper kit contains a low profile, seven-speed wiper motor with five delays, low speed, and high speed.

Selecta-Speed™ WIPER KIT FEATURES:

- Easy installation
- Push-button windshield washer function
- Smaller, lighter wiper motor



SHOWN: 1963-1967 Corvette Selecta-Speed™ Wiper Kit

ALSO AVAILABLE FOR:

- CAMARO
- CHEVELLE
- CHEVY II
- CORVETTE
- C-10 TRUCK
- EL CAMINO
- FIREBIRD
- MUSTANG
- NOVA



Complete your kit with the optional Detroit Speed Windshield Washer Pump Kit.



Visit Detroit Speed's YouTube channel for video profiles of the Selecta-Speed™ Wiper Kits and Headlight Kits.



HEADLIGHT KITS

Detroit Speed's electric headlight door kit replaces the stock vacuum actuated system on headlamp equipped 1968-69 RS Camaros, the stock electric actuated system on 1963-67 Corvettes, and the vacuum actuated system for the 1968-82 Corvettes. It makes converting your vehicle to hide-away headlights much easier.

When installed, this kit will operate the headlight doors more reliably, smoother and without the complicated and bulky vacuum accessories.



ELECTRIC HEADLIGHT DOOR KIT INCLUDES:

- Two electric actuators
- Control module
- Electric harness
- Mounting brackets
- All necessary hardware

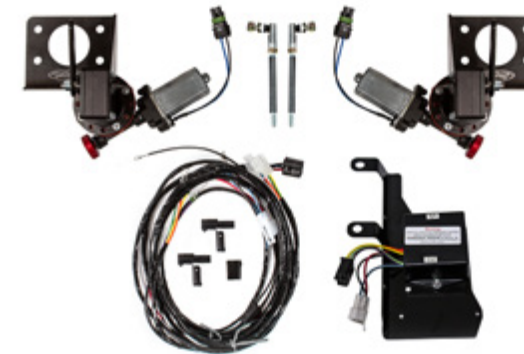

SHOWN: 1968-1982 Corvette Electric Headlight Door Kit

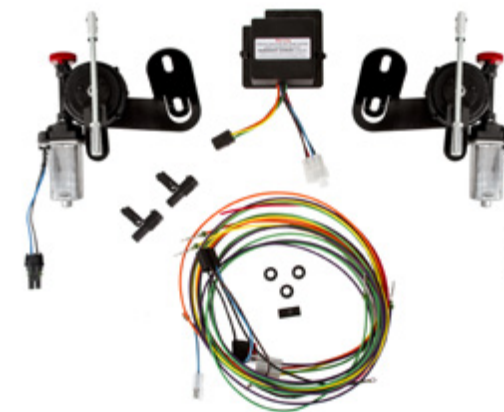

SHOWN: 1969 RS Camaro Electric Headlight Door Kit



STEERING GEAR & RACK

Detroit Speed's rack and pinions have been optimized to provide an exceptional modern performance feel on the street and on the track. They are available in both standard (24.5") and narrow (21.5") widths. Detroit Speed's 21.5" width is one of the shortest racks in the aftermarket industry.

Every rack undergoes a rigorous quality check and is performance tested prior to being shipped.

'DETROIT TUNED' STEERING RACK:

- 'Detroit Tuned' valving specifically to provide the increased effort and performance feel found in late model performance vehicles
- All new components
- Every rack undergoes a rigorous quality check and is performance tested prior to being packaged
- Includes polyurethane mounting bushings
- Features an internal, inner tie rod boot balance tube



Now you can achieve rack and pinion steering performance with a bolt-in steering gear. This steering gear can be used to replace the common GM power steering gear box used from 1964-1992.

600 STEERING GEAR FEATURES:

- All new steering gear unit, not rebuilt
- Late model performance car feel
- Quick ratio 12.7:1 or new 10:1 ratio
- 6 pounds lighter than stock



HARDLINE CONVERSION KIT:

The Detroit Speed rack and pinion fluid transfer conversion kit is an optional upgrade to replace the standard hardlines on your Detroit Speed rack and pinion using -4AN steel fittings.

The hoses are Teflon lined to handle the high pressure demands of the steering system and come with pre-cripped stainless-steel fittings to attach to the -4AN fittings.



POWER STEERING

POWER STEERING PUMPS:

Detroit Speed's power steering pumps are compatible with any power steering gear or rack and pinion. The housing has a cast aluminum finish and the integral reservoir makes for a clean, compact package. Detroit Speed also offers a power steering pump to be used with a remote reservoir. All Detroit Speed pumps are compatible with Vintage Air's Front Runner™ accessory drive system.

Flow	3.0-3.4 gallons per minute at 1500 rpm
Pressure Relief	1250-1450 psi



Aluminum For Remote Reservoir



Aluminum with Integral Reservoir

POWER STEERING HOSE KITS:

The Detroit Speed stainless-steel power steering hose kit includes fittings to convert your steering gear or rack and pinion to -6AN fittings. Each kit includes 30" of hose length that can be routed and cut to length at the pump end.



POWER STEERING FLOW CONTROL VALVE:

This flow correction fitting will reduce flow from 3 gal/min to approximately 2 gal/min while retaining the appropriate pressure in the system. This flow correction fitting should be used when a GM power steering pump is used with a Mustang II rack and pinion.



TECH TIP: A power steering pump with a 3 gal/min flow rate can overboost a Ford rack and pinion. The steering will feel "twitchy" or "nervous" if this flow correction fitting is not used.

ROLL CAGES

Detroit Speed's roll cages are manufactured for increased chassis strength and additional safety. The pre-notched, pre-bent design follows the interior lines of the car and does not interfere with interior comfort. Detroit Speed roll cages package close to the headliner and back window glass for a seamless fit.

SHOWN: 1970-1981 Camaro/Firebird Roll Cage



SHOWN: 1967-1969 Camaro/Firebird Roll Cage



ROLL CAGE FEATURES:

- 1-5/8" x .134" mild steel tubing
- Removable cross bar with Detroit Speed CNC-machined steel clevis for easier removal
- Pre-bent rocker panel floor plates
- Pre-bent trunk floor plates for mini-tubbed and stock trunk pans

NOTE: Roll cage is not intended for use with back seat passengers. It does not meet NHRA/IHRA requirements due to the removable cross bar. Installation requires welding.



HEADERS

Detroit Speed's stainless-steel headers feature a 1-7/8" primary tube diameter with four-way merge collectors featuring V-Band clamps and 3/8" thick flanges. These headers are designed for performance, maximum ground clearance and a clean engine compartment appearance. They are durable, attractive and come with the necessary clamps to make installation easy. Each header features an O2 sensor bung in the collector.

SHOWN: 1967-1981 Camaro/Firebird & 1968-1974 Nova

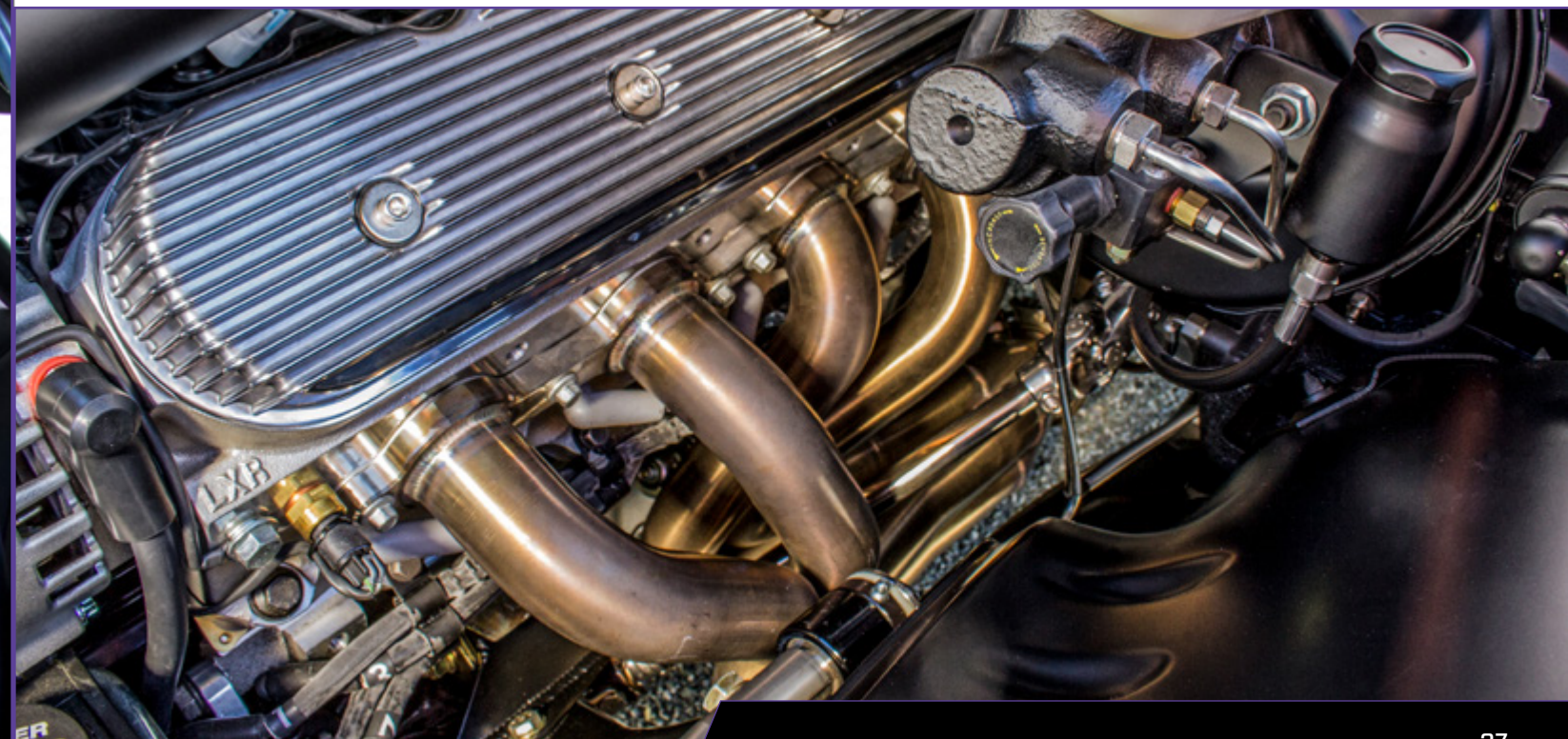

FUEL TANKS

Detroit Speed's stainless-steel narrowed fuel tanks are designed specifically for use with its QUADRALink™ rear suspension or mini-tub kits. These are a direct bolt-in tank using the original mounting location and are available for fuel injected or carbureted engines.



DESIGNED FOR VEHICLES WITH 600HP THAT ARE USING AN INTERNAL FUEL PUMP FOR IMPROVED FUEL PICK-UP



DESIGNED FOR VEHICLES WITH 1000HP USING A DUAL INTERNAL FUEL PUMP SYSTEM WITH AN ELECTRONIC CONTROLLER

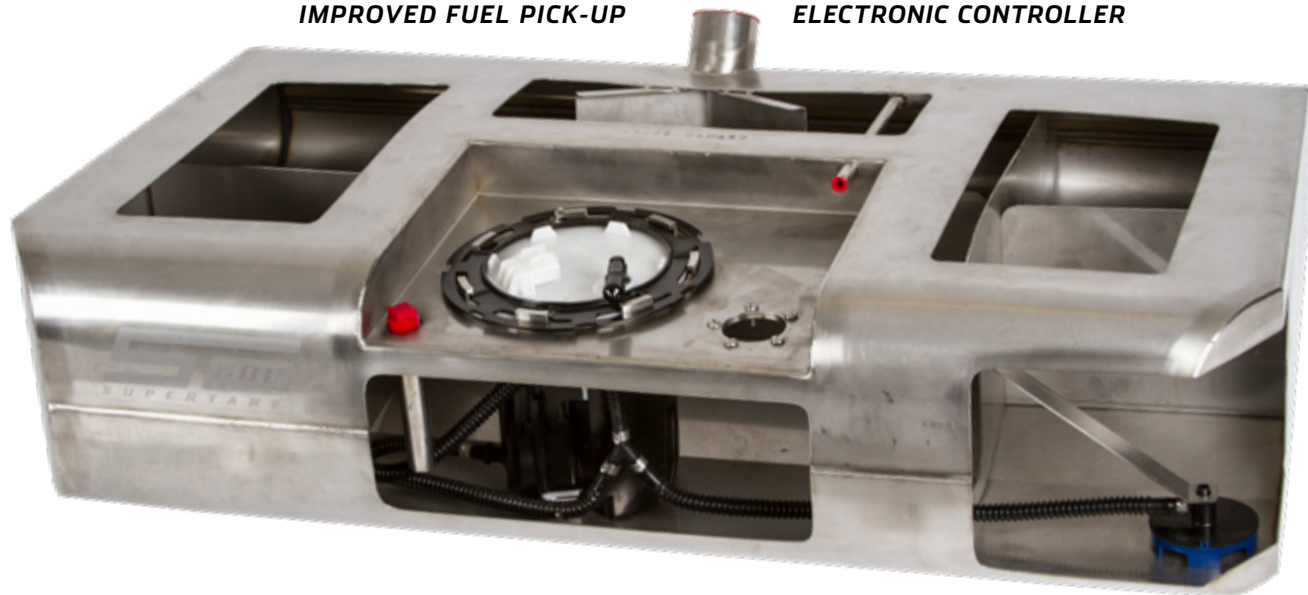

Both the 600 and 1000 Series tanks have corner pickups built into the tank to eliminate the possibility of fuel starvation during extreme cornering without having a full tank. Stainless-steel fuel tank straps are provided. All tanks are baffled and pressure-tested.



SHOWN: 1964.5-1970 Mustang Fuel Tank for Mini-Tub or Stock Application



SHOWN: 1964.5-1970 Mustang Stainless Super Tank for QUADRALink™ Application



SHOWN: 1967-1969 Camaro/Firebird Stainless Steel Tank

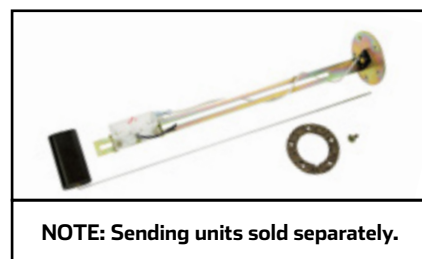

NOTE: Sending units sold separately.

AXLES

Detroit Speed manufactures both Ford 9" and GM 12-Bolt rear axle housings. Rear axles can be shipped completely set up and ready to place underneath your vehicle, or as a ready-to-assemble unit.

OPTIONAL FORD 9" COMPLETE REAR AXLE:

- Heavy-duty round back housing, TIG-welded, centerless ground 3" x .250" steel tube, 1350 yoke, Truetrac, 31-spline axles, 1/2" studs, narrowed to any width
- QUADRALink™ brackets TIG-welded to housing*
- Billet Torino ends and axle vent
- Fill and drain plugs standard
- N Case center section with pinion support with large Daytona-style pinion bearing

*When ordered with the QUADRALink™ kit



Call the Detroit Speed Sales Department for application-specific needs.

FULL FLOATER KIT:

The Detroit Speed Full Floater Kit provides consistent and confident braking by eliminating axle shaft flex. The kit utilizes a C6/C7 bearing pack allowing the use of the factory ABS system. The Detroit Speed Full Floater Kit is compatible with stock GM C6/C7 or aftermarket C6 rear brake systems.



NOTE: Both Ford 9" and GM 12-Bolt axles can be upgraded to include floater ends.

OPTIONAL GM 12-BOLT COMPLETE REAR AXLE:

- USA cast, TIG-welded, centerless ground 3" x .250" steel tube, Truetrac, 30-spline axles, 1350 yoke, 1/2" studs, narrowed to any width
- QUADRALink™ brackets TIG-welded to housing*
- Billet Torino ends and axle vent

*When ordered with the QUADRALink™ kit



Upgraded Detroit Speed Aluminum Support Cover for 12-Bolt rear axles only.

NOTE: GM 12-Bolt can be upgraded to 33-spline axles.

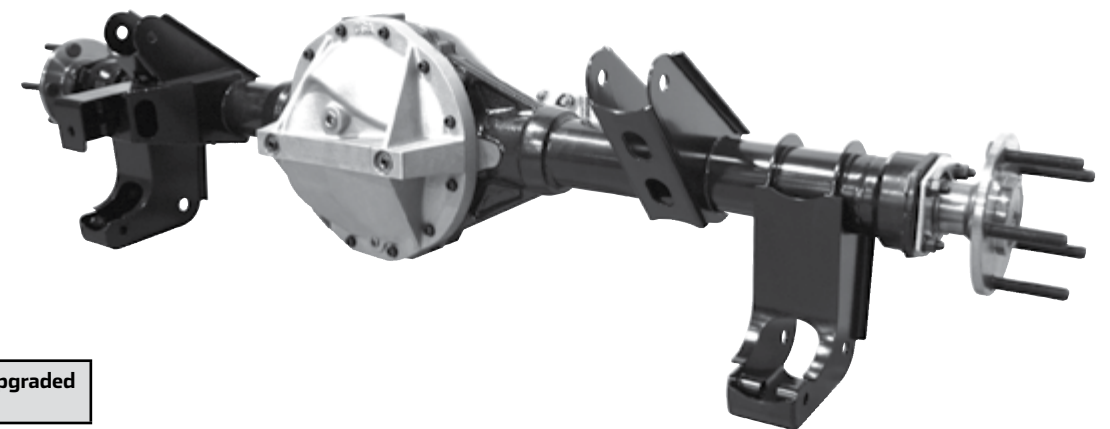

MISCELLANEOUS PRODUCT

HEAVY-DUTY LEAF SPRING POCKET KIT:

The Detroit Speed Heavy-Duty Leaf Spring Pocket Kit was engineered to work with stock leaf spring cars as well as cars with the Detroit Speed QUADRALink™. The kit is significantly stronger than the stock pocket. It connects into the doubler plate on the top side floor pan and offers an additional link mounting location that is 1" lower than the stock location.

The assembly is bolt-on for easy installation and may be removed after painting. All necessary hardware is included.



SHOWN: 1967-1969 Camaro/Firebird Heavy-Duty Leaf Spring Pocket Kit

SHOWN: 1968-1974 Nova Heavy-Duty Leaf Spring Pocket Kit

BOLT-ON
OR
WELD-IN

OFFSET SHACKLE SET:

Detroit Speed's exclusive billet aluminum offset shackles are designed to relocate the rear leaf springs inboard to accommodate up to 335 rear tires. The shackles were computer modeled and optimized with FEA, tested and then CNC-machined. The shackle offset is 1-3/4". This set includes four offset shackles and Grade-8 fasteners.



AVAILABLE FOR:

Camaro
Firebird
Nova

NOTE: Detroit Speed's narrowed stainless-steel fuel tank is required when relocating the rear leaf springs.
NOTE: The offset shackles were designed to be used with the Detroit Speed rear drop leaf springs. They were not designed to be used with reverse eye leaf springs.

DETROIT SPEED BODY MOUNTS:

Detroit Speed's solid body mounts provide a simple approach to eliminating the flex that occurs between the body and subframe connection. This will improve vehicle handling response by increasing chassis stiffness. These mounts should be used when installing subframe connectors for maximum torsional rigidity.

AVAILABLE FOR:

Camaro
Firebird
Nova



Full-Height Body Mounts

Half-Height Body Mounts

BODY MOUNT FEATURES:

- CNC-machined from billet aluminum
- Hard coated to resist corrosion
- Available for stock height and half-height

KIT INCLUDES:

- Two core support mounts with stainless steel bevel washers
- Four body mounts with stainless steel bevel washers



STAINLESS BODY BOLT KIT (OPTIONAL FOR BODY MOUNTS)

KIT INCLUDES:

- Two polished 17-4 stainless-steel bolts and nuts for core support mounts
- Four polished 17-4 stainless-steel bolts for body mounts

MISCELLANEOUS PRODUCT

ENGINE MOUNT KIT:

Detroit Speed engine mount bracket kits enable easy, no hassle installation of any SBC, BBC or LS engine. These mounting bracket kits can be used on both Detroit Speed subframes and stock frames.

KIT INCLUDES:

- Frame side engine mount stands
- CNC aluminum adapter plates
- Polyurethane engine mounts

AVAILABLE FOR:

Camaro
Firebird
Mustang
Nova
Chevy II



NOTE: 060401 engine mounts can be used with a stock subframe.
NOTE: 060404 engine mounts relocate the engine back 1.5" from stock location while clearing the firewall.



UNIVERSAL SEAT SLIDER MOUNT KIT:

Detroit Speed's Universal Seat Slider Mount Kit is CNC-machined from 6061 aluminum and includes push-button quick release pins. The seat mount slider track comes with laser engraved numbers to quickly identify your seat position with up to 7-1/2" of seat adjustment. This kit is sold individually per seat.

WARNING: This kit is not intended for street/highway use vehicles.

NOTE: This is a universal kit and is not a direct fit for any specific vehicle. You will need to fabricate a floor structure based on your vehicle to properly install this kit.

DETROIT SPEED BY CLASSIC INSTRUMENTS:

New in 2017, Detroit Speed partnered with Classic Instruments to offer a Detroit Speed-branded Six-Gauge Cluster Set. These full-sweep performance gauges provide increased accuracy with an easy to read 2-5/8" size gauge and they feature microprocessor technology for precision and durability. The fuel gauge has a programmable resistance range so it is compatible with any fuel sending unit.

GAUGE SET FEATURES:

- Matte-black low step bezels and flat glass lenses
- 2-5/8" fuel, water temp, volt, oil pressure
- 4-5/8" speedometer and tach
- Integrated red warning light
- Additional warning indicator light output
- Push-button calibration
- Installation hardware and wiring harness included



NOTE: GM Sending Units included.

APPAREL

Throw your fashion into high gear, or add some style to your garage with Detroit Speed apparel and accessories. Rep the brand you know and trust, or give a gift to a fellow enthusiast.

LOGO TEES



DSE-Z "MULLET" TEE

"MAKING AMERICA FAST AGAIN" TEE



SPECIAL EDITION SHIRTS

OUTERWEAR



ACCESSORIES

FOR YOUR GARAGE



FOR YOUR RIDE



DETROIT SPEED LICENSE PLATE



FOR YOURSELF

