

**J.W. SPEAKER®**  
*Engineered. Lighting. Solutions.*

# HEADLIGHT CATALOG

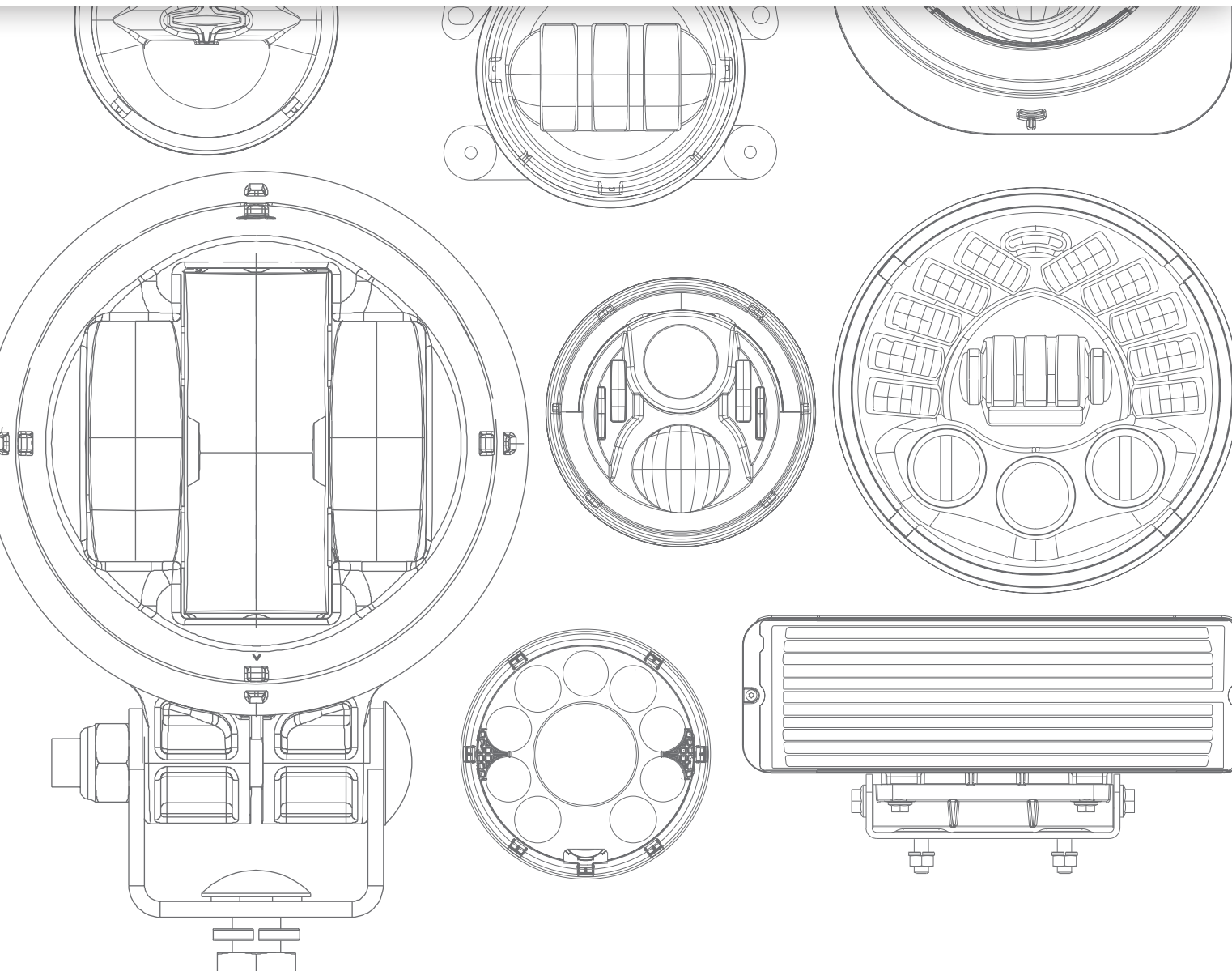

# J.W. SPEAKER BRINGS SCIENCE & DESIGN TOGETHER.

**We view vehicle lighting from the perspective that matters most — Yours.** Our engineers advance the science of light further each day to improve your safety. Our designers make vehicles look more beautiful from every point of view. You only get this unique mix of **science & design** from authentic J.W. Speaker products.



# TABLE OF CONTENTS

---

Regulations & Key Terms	4
Lumens & Beam Patterns	5
Color Temperature & IP Ratings	6
<b>Automotive</b>	<b>7-19</b>
Transport	20-40
SmartHeat®	41
Company History	42-43
<b>Power Sports</b>	<b>44-62</b>
<b>Industrial</b>	<b>63-73</b>
Index	74-75
OEM	76
Aftermarket	77



# REGULATIONS

---

## SURPASSING STANDARDS WORLDWIDE.

J.W. Speaker is committed to making the best products to be used legally on-road around the world. To do that, we design lights that meet and exceed the requirements for a variety of regulations:



The Federal Motor Vehicle Safety Standard regulates all automotive lighting, signaling, and reflective devices in the U.S.A. and is enforced by the Department of Transportation (**DOT**)



Many countries recognize the United Nations Economic Commission for Europe (**ECE**) Transport Division's regulations and mirror the ECE regulations in their own national requirements



**SAE** International develops standards for the engineering of powered vehicles mainly in the U.S.A. and Canada, including cars, trucks, boats, aircraft, and more



**Transport Canada** is responsible for developing regulations, policies, and services relating to transportation in Canada



The Australian Design Rules (**ADR**) are national standards for vehicle safety, anti-theft, and emissions

## KEY TERMS

---

**Daytime Running Light (DRL):** Headlights that include DRL in their design will automatically switch on the daytime running lamp when the vehicle is moving forward, emitting a white light to increase the visibility of the vehicle during daylight conditions.

**Front Position (FP):** This part of a headlight provides added visibility of your vehicle to other drivers, particularly helpful for nighttime visibility while parked.

**Left Hand Traffic (LHT):** referring to which side of the road a driver uses. For instance, a driver in the UK is Left Hand Traffic and would use two LHT lights.

**Right Hand Traffic (RHT):** referring to which side of the road a driver uses. For instance, a driver in Canada is Right Hand Traffic would use two RHT lights.



# LUMENS & BEAM PATTERNS

## RAW LUMENS:

A measure of the **theoretical** output of a light

**Calculated** by multiplying the manufacturer's lumen rating for the LED by the number of LEDs in the finished light

**Does not represent** the actual light output as it doesn't account for thermal, assembly and optical losses that impact all lights

### Example Calculation:

LED is rated at 100 Lumens

8 LEDs in the finished light

**100 x 8 = 800 Raw Lumens**

## EFFECTIVE LUMENS:

A measure of the **actual** output of a light

**Measured** using a photometric testing device for an exact measurement of a finished light for an accurate value of light output

**Represents** the actual light output of the finished light after thermal, assembly and optical losses

### Example Measurement:

Raw Lumens = 800

Losses = ~40% of Raw Lumens (800 x .4 = 320)

**800 - 320 = 480 Effective Lumens**

J.W. Speaker uses photometric testing devices and optical engineers to measure the Effective Lumens of our products to give you accurate light output values.

## BEAM PATTERNS

Each light pattern is designed and tested by optical engineers to give you the best possible beam pattern to drive behind.

Below are examples of the common beam patterns.

Our engineers design each product to project light in the areas you need it **and** comply with the legal requirements for on-road use in the countries the product is intended to be used in.

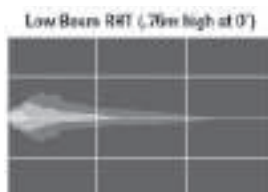

Illuminates across the road and ahead of the vehicle, with a cutoff to prevent glare for oncoming traffic

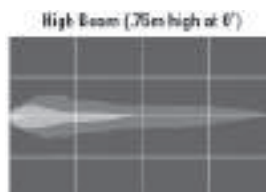

Bright light for distance illumination above and below the horizon, when not following or passing vehicles

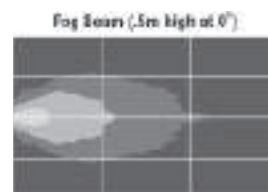

Short and wide pattern to illuminate area just above the ground & in front of the vehicle

## PARTS OF A LIGHT DIAGRAM

**Lux Key<sup>1</sup>:** Intensity of the light measured

**Title<sup>2</sup>:** The type of beam pattern, and the height and angle of the light when it was measured

**Light Pattern<sup>3</sup>:** A "bird's eye view" showing the shape, intensity, and distance

**Distance Markers<sup>4</sup>:** Reference in meters (m) for the size and distance of the light pattern

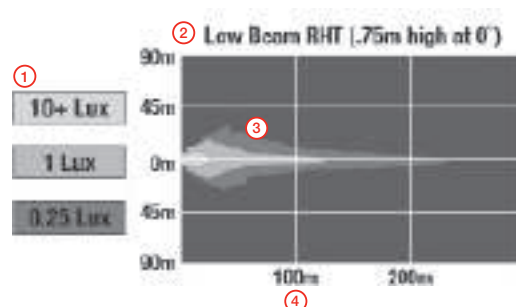

# COLOR TEMPERATURE & IP RATINGS

Measured in degrees Kelvin, color temperature describes how cool or warm the light emitted by a source is. Any object will emit light if it is heated to a high enough temperature. The color of the light will change in a predictable way as the temperature increases, shown on the Kelvin Scale.

## Warm: 0 to 3,000K

Used in living spaces or retail stores  
 Similar to the rising and setting sun  
 Can fatigue eyes and make people feel tired

## Neutral White: 3,500 to 4,900K

Used in bathrooms, offices, classrooms & malls  
 Clean and neutral lighting that is inviting  
 Promotes efficiency and similar to daylight

## Cool: 5,000-7,000K

Used in hospitals, manufacturing, & construction areas  
 Promotes alertness and attention to detail  
 Mimics daylight and makes people feel more awake

J.W. Speaker uses LEDs and designs lights with a color temperature of 5,000K to give drivers crisp, white light for the best visibility, and to promote alertness and safety.

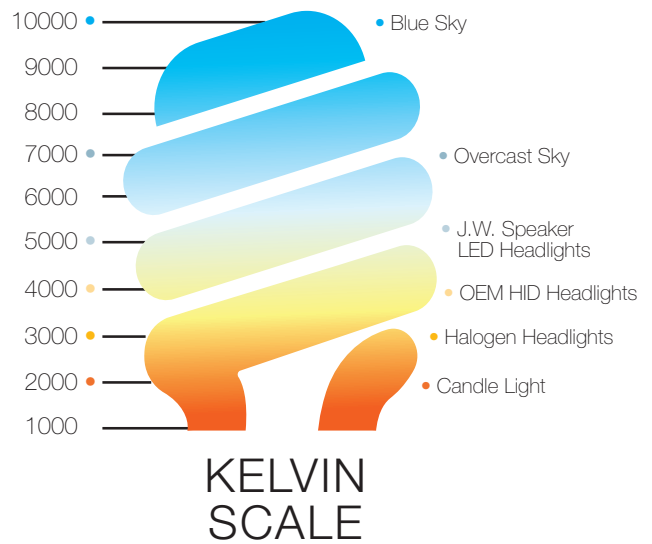

Color temperature does not measure or indicate the physical heat coming from a light source.

## IP RATINGS

The Ingress Protection (IP) Code outlines a system of classification for the protection of electrical enclosures against the intrusion of foreign bodies like tools, fingers, dust, and moisture. The system of classification was specified by the International Electrotechnical Commission and is officially designated as IEC 60529.

### FIRST # - DEGREE OF INGRESS PROTECTION

The degree of protection against contact with moving parts and the degree that the equipment is protected against solid foreign bodies intruding into an enclosure.

IP #	DESCRIPTION
0	No protection provided.
1	Protection against entry of objects larger than 50 square mm.
2	Protection against entry of objects larger than 12 square mm.
3	Protection against entry of objects larger than 2.5 square mm.
4	Protection against entry of objects larger than 1.0 square mm.
5	Protection against entry of dust in sufficient quantity to prevent satisfactory operation.
6	Complete protection against entry dust.

### SECOND # - DEGREE OF MOISTURE PROTECTION

The degree of protection for the equipment inside the enclosure against the harmful entry of various forms of moisture (e.g. dripping, spraying, submersion, etc.)

IP #	DESCRIPTION
0	No protection provided.
1	Protection against drops of water falling vertically.
2	Protection against drops of water falling vertically when the light assembly is tilted up to 15 degrees from its normal position.
3	Protection from entry of water spray from angle of up to 60 degrees from vertical.
4	Protection from entry of water splashes or spray from any direction.
5	Protection from a low pressure jet of water in any direction.
6	Protection against heavy seas or a strong jet of water in any direction.
7	Protection against immersion up to 1 meter.
8	Protection against submersion over 1 meter.



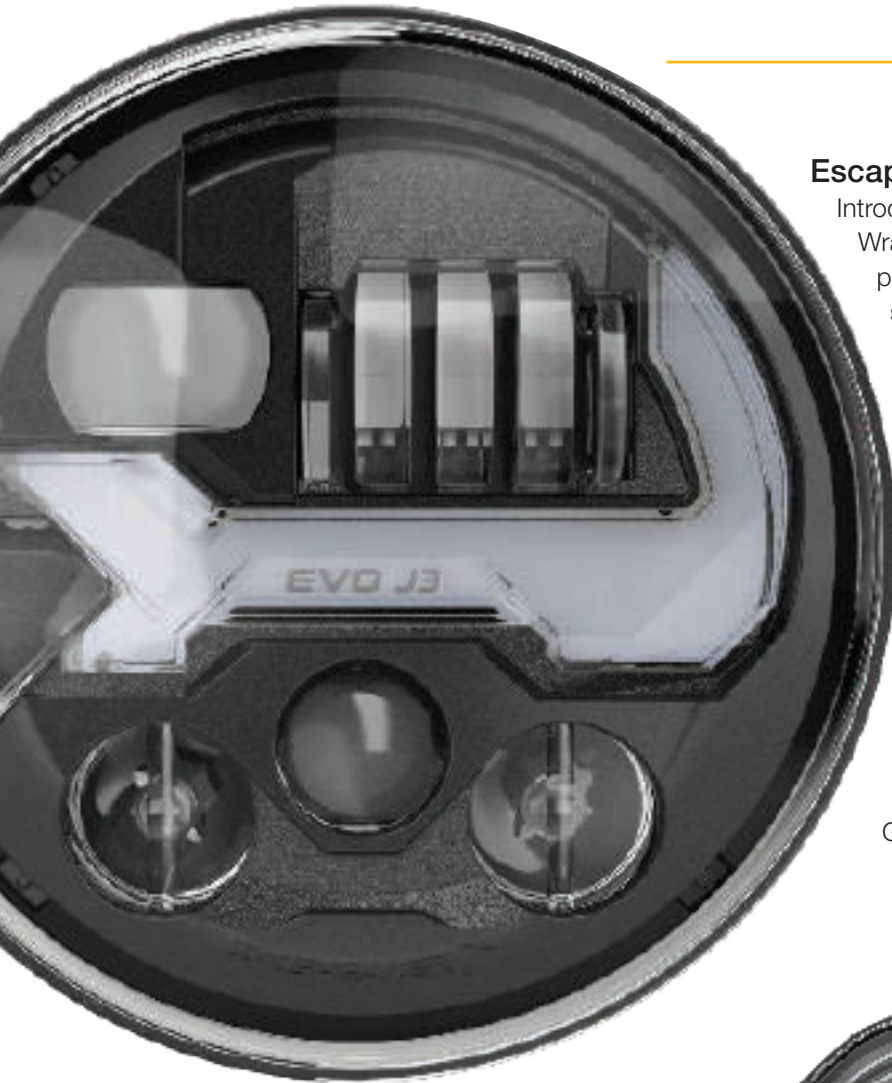

## Escape the standard.

Introducing the latest technology in lighting for Jeep® Wranglers. The EVO J3 is the first street-legal, plug & play Jeep headlight with a built-in turn signal. Powerful LEDs and carefully engineered light patterns give you the best performance and design available whether on the road or exploring off-road.

## Light your adventure all year round.

The heated version of the EVO J3 features SmartHeat® technology to de-ice lenses for the best safety and visibility.

## Customizing & control at your fingertips.

Unlock more control and features in the EVO J3 using the new **J-Link™ mobile app**. Customize your startup sequence, access the Off-Road Mode and lead the trail with Guide Mode.

## PRODUCT SPECIFICATIONS

### Raw Lumen Output:

3,600 (High Beam); 3,020 (Low Beam)

### Effective Lumen Output:

1,320 (High Beam); 1,201 (Low Beam)

### Candela Output:

68,800 (High Beam); 24,800 (Low Beam)

### Connector/Wiring:

H13 Delphi 15326813

### Operating Voltage:

9-16V DC

### Current Draw:

Low Beam: 2.33A @ 12V DC

High Beam: 3.25A @ 12V DC

Front Turn: 3.00A @ 12V DC

Daytime Running Light (DRL): 3.00A @ 12V DC

Front Position: 0.45A @ 12V DC

### Retrofit Information:

Jeep JK 2010-2018

### Standards:

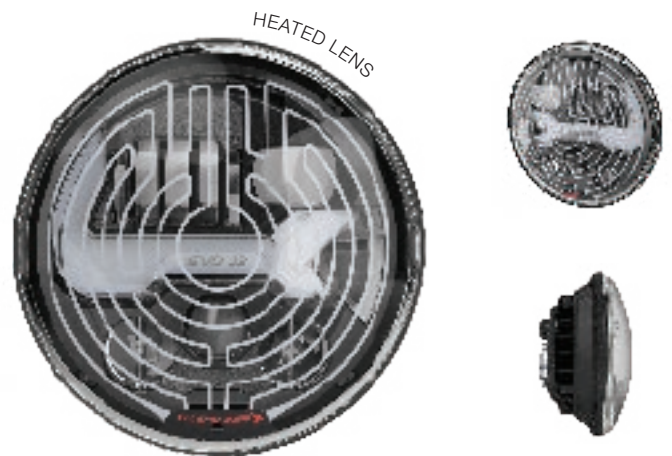

TURN SIGNAL



OFF-ROAD MODE



DRL



LOW BEAM



HIGH BEAM



Jeep is a registered trademark of FCA US LLC.





**EVO J3™**

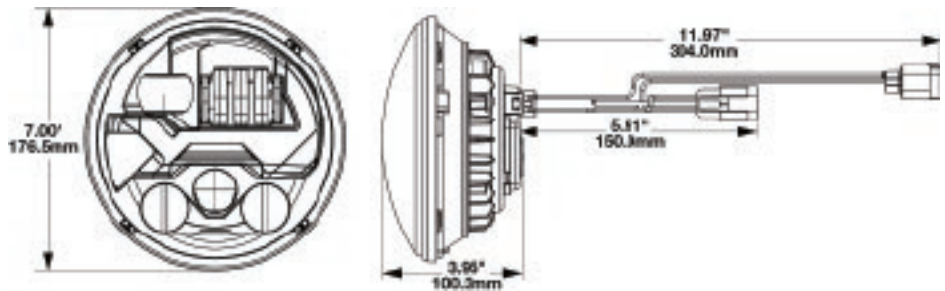

**HEATED**

PART #	BEZEL	DESCRIPTION
0555613	Graphite	DOT/Kit of 2
0557213	Black	DOT/Kit of 2
0555663	Graphite	ECE/RHT/Kit of 2
0557243	Black	ECE/RHT/Kit of 2
0555623	Graphite	ECE/LHT/Kit of 2
0557223	Black	ECE/LHT/Kit of 2

**NON-HEATED**

PART #	BEZEL	DESCRIPTION
0555593	Graphite	DOT/Kit of 2
0557193	Black	DOT/Kit of 2
0555653	Graphite	ECE/RHT/Kit of 2
0557233	Black	ECE/RHT/Kit of 2
0555603	Graphite	ECE/LHT/Kit of 2
0557203	Black	ECE/LHT/Kit of 2

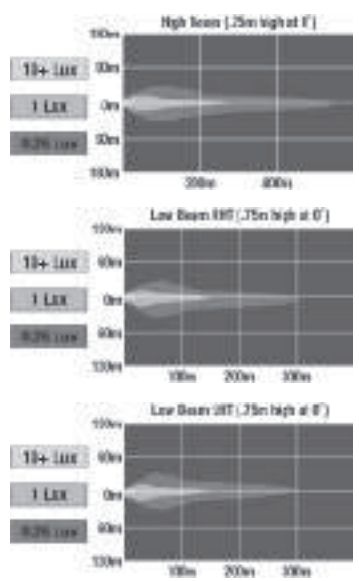

UNLOCK FEATURES WITH  
**J-LINK™**

**Bluetooth®**

**SmartHeat!**  
HEATED LIGHTING TECHNOLOGY

# 6145 J2 FOG LIGHT



## PRODUCT SPECIFICATIONS

**Raw Lumen Output:**  
1,080

**Effective Lumen Output:**  
610

**Connector/Wiring:**  
Packard 12059183

**Operating Voltage:**  
10-15V DC

**Current Draw:**  
1.60A @ 12V DC

**Retrofit Information:**  
4" Round; Jeep Wrangler JK 2007- 2018

**Standards:**

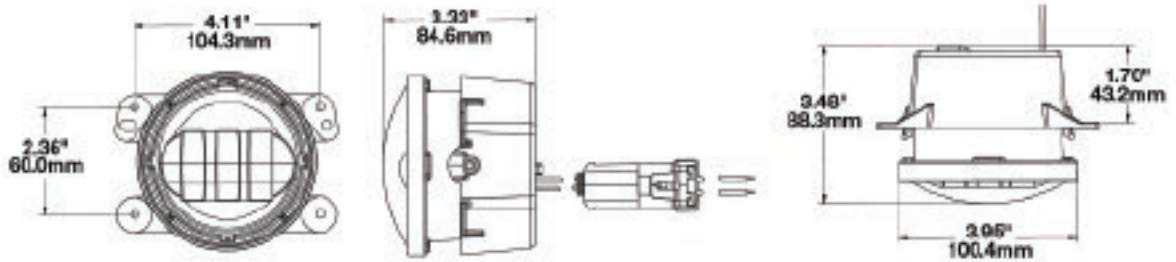

PART #	BEZEL	DESCRIPTION
0554413	Carbon Fiber	SAE/ECE/Fog/Kit of 2
0554573	Black	SAE/ECE/Fog/Kit of 2

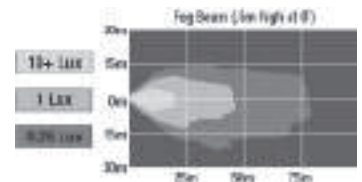

# 6146 FOG LIGHT

## PRODUCT SPECIFICATIONS

**Raw Lumen Output:**  
1,080

**Effective Lumen Output:**  
610

**Connector/Wiring:**  
Packard 12059183

**Operating Voltage:**  
10-15V DC

**Current Draw:**  
1.6A @ 12V DC

**Retrofit Information:**  
4" Round; 2005-2014 Ford F-150s

**Standards:**

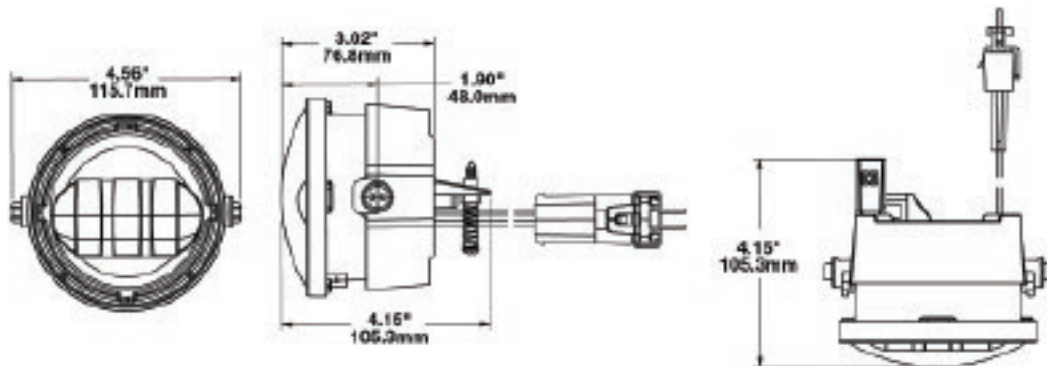

PART #	BEZEL	DESCRIPTION
0549671	Black	SAE/ECE/Fog/Kit of 2 for 2005-2010 Ford F-150
0549681	Chrome	SAE/ECE/Fog/Kit of 2 for 2005-2010 Ford F-150
0549651	Black	SAE/ECE/Fog/Kit of 2 for 2011-2014 Ford F-150
0549661	Chrome	SAE/ECE/Fog/Kit of 2 for 2011-2014 Ford F-150

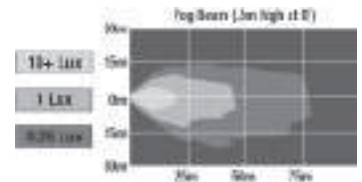

# 8700 EVO 2 DUAL BURN



## PRODUCT SPECIFICATIONS

### Raw Lumen Output:

3,200 (High Beam); 1,770 (Low Beam)

### Effective Lumen Output:

1,260 (High Beam); 750 (Low Beam)

### Candela Output:

71,500 (High Beam); 35,003 (Low Beam)

### Connector/Wiring:

H4

### Operating Voltage:

9-32V DC

### Current Draw:

Heated High Beam: 4.20A @ 12V; 2.30A @ 24V DC

High Beam: 3.50A @ 12V; 1.80A @ 24V DC

Low Beam: 2.00A @ 12V; 1.10A @ 24V DC

Front Position: 0.16A @ 12V; 0.10A @ 24V DC

DRL: 1.60A @ 12V; 0.80A @ 24V DC

### Retrofit Information:

7" Round (PAR56)

### Standards:

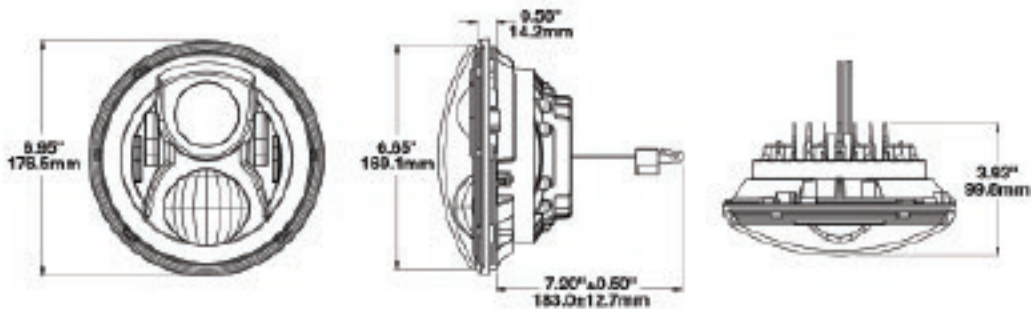

### HEATED

PART #	BEZEL	DESCRIPTION
0556281	Black	DOT/High/Low
0556291	Chrome	DOT/High/Low
0556301	Black	ECE/RHT/High/Low/FP/DRL
0556311	Chrome	ECE/RHT/High/Low/FP/DRL
0556321	Black	ECE/LHT/High/Low/FP/DRL
0556331	Chrome	ECE/LHT/High/Low/FP/DRL

### NON-HEATED

PART #	BEZEL	DESCRIPTION
0554941	Black	DOT/High/Low
0554961	Chrome	DOT/High/Low

### PART # ACCESSORIES

3156561	Panel Mount Bucket Assembly
3156351	Mounting Ring Kit for 7" Round (PAR56) Headlights
3266081	Jumper Harness H4/H13
8000381	Anti-Flicker Harness H4/H4
8000311	Anti-Flicker Harness H4/H13

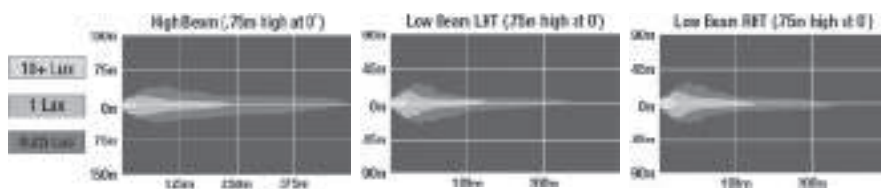

# 8700 EVO 2 PRO

## PRODUCT SPECIFICATIONS

### Raw Lumen Output:

4,170 (High Beam); 2,340 (Low Beam)

### Effective Lumen Output:

1,340 (High Beam); 694 (Low Beam)

### Candela Output:

84,700 (High Beam); 30,600 (Low Beam)

### Connector/Wiring:

H4

### Operating Voltage:

9-32V DC

### Current Draw:

High Beam: 3.60A @ 12V; 1.80A @ 24V DC

Low Beam: 2.00A @ 12V; 1.10A @ 24V DC

Front Position: 0.16A @ 12V; 0.10A @ 24V DC

DRL: 1.60A @ 12V; 0.80A @ 24V DC

### Retrofit Information:

7" Round (PAR56)

### Standards:

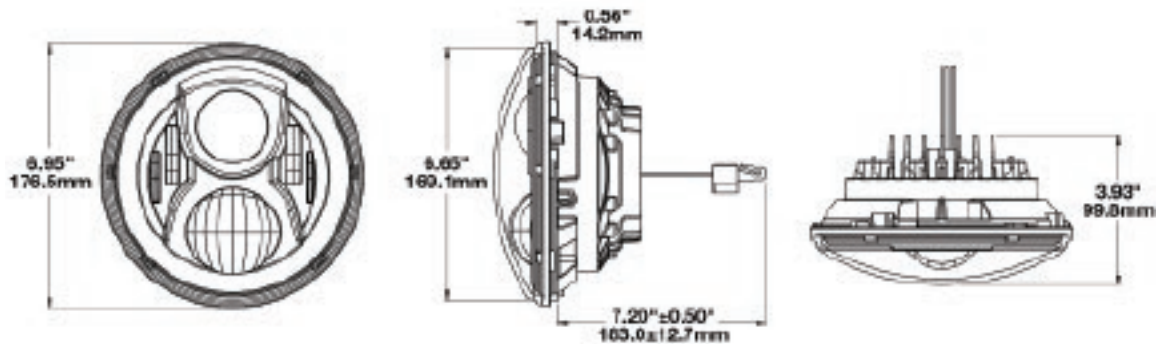

### PART # BEZEL DESCRIPTION

0556981 Black ECE/RHT/High/Low

0556971 Chrome ECE/RHT/High/Low

0556961 Black ECE/LHT/High/Low

0556951 Chrome ECE/LHT/High/Low

### PART # ACCESSORIES

3156561 Panel Mount Bucket Assembly

3156351 Mounting Ring Kit for 7" Round (PAR56) Headlights

3266081 Jumper Harness H4/H13

8000311 Anti-Flicker Harness H4/H13

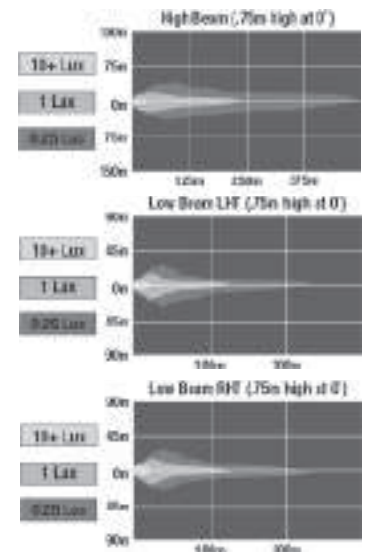

# 8700 EVO J CLASSIC



## PRODUCT SPECIFICATIONS

### Raw Lumen Output:

3,200 (High Beam); 1,770 (Low Beam)

### Effective Lumen Output:

1,260 (High Beam); 750 (Low Beam)

### Candela Output:

71,500 (High Beam); 35,003 (Low Beam)

### Connector/Wiring:

H13

### Operating Voltage:

9-16V DC

### Current Draw:

High Beam: 4.2A @ 12V DC

Low Beam: 2.0A @ 12V DC

### Retrofit Information:

7" Round (PAR56); Jeep Wrangler JK 2007-2018

### Standards:

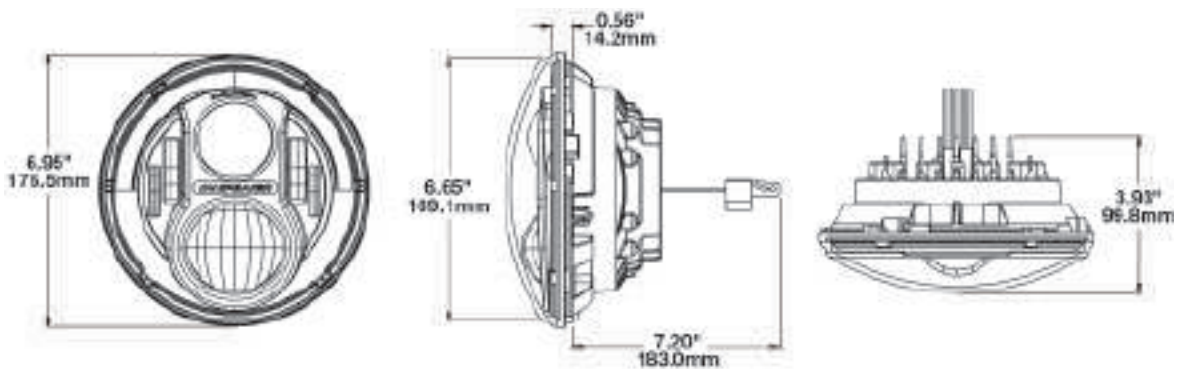

### PART # BEZEL DESCRIPTION

0556793 Black DOT/ECE/High/Low/Kit of 2

### PART # ACCESSORIES

3156561 Panel Mount Bucket Assembly

3156351 Mounting Ring Kit for 7" Round (PAR56) Headlights

8000381 Anti-Flicker Harness H4/H4

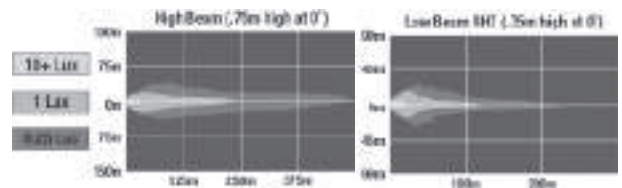

# 8700 EVOLUTION 2R

## PRODUCT SPECIFICATIONS

### Raw Lumen Output:

3,200 (High Beam); 1,770 (Low Beam)

### Effective Lumen Output:

1,260 (High Beam); 750 (Low Beam)

### Candela Output:

71,500 (High Beam); 35,003 (Low Beam)

### Connector/Wiring:

Delphi 33500006

### Operating Voltage:

9-16V DC

### Current Draw:

High Beam: 4.00A @ 12V DC

Low Beam: 2.70A @ 12V DC

### Retrofit Information:

Jeep® Renegades

### Standards:



CHROME, RH & LH KIT



BLACK, RH

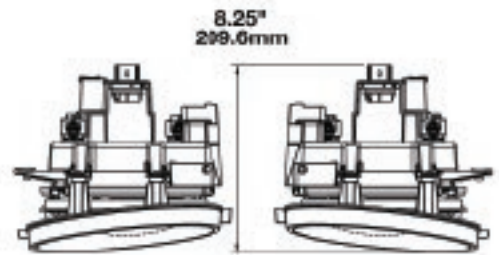
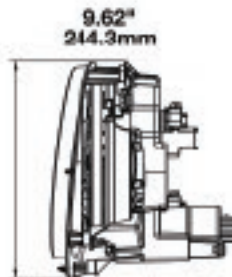
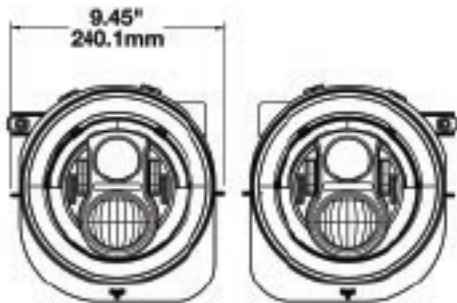

PART #	BEZEL	DESCRIPTION
0554263	Chrome	DOT/High/Low/Kit of 2
0553623	Black	DOT/High/Low/Kit of 2

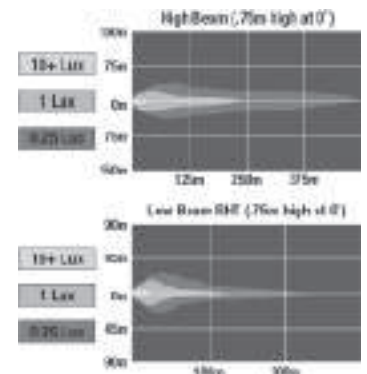

# 8700 EVOLUTION J2



## PRODUCT SPECIFICATIONS

### Raw Lumen Output:

3,200 (High Beam); 1,770 (Low Beam)

### Effective Lumen Output:

1,260 (High Beam); 750 (Low Beam)

### Candela Output:

71,500 (High Beam); 35,003 (Low Beam)

### Connector/Wiring:

H13 Delphi 15326813

### Operating Voltage:

9-16V DC

### Current Draw:

High Beam: 4.20A @ 12V DC

Low Beam: 2.00A @ 12V DC

### Retrofit Information:

7" Round (PAR56); Jeep Wrangler JK 2007-2018

### Standards:

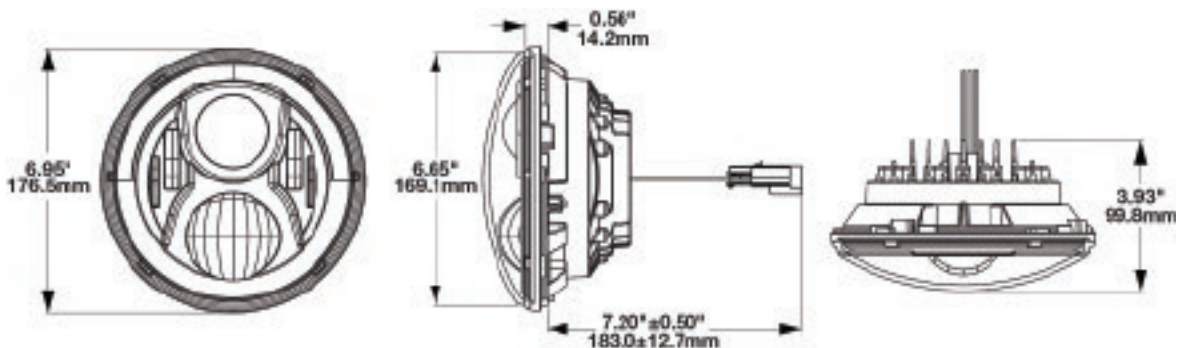

### KIT OF 2 HEADLIGHTS

PART #	BEZEL	DESCRIPTION
0553973	Carbon Fiber	DOT/High/Low/Kit of 2
0554543	Black	DOT/High/Low/Kit of 2
0553983	Carbon Fiber	ECE/RHT/High/Low/Kit of 2
0554553	Black	ECE/RHT/High/Low/Kit of 2
0553993	Carbon Fiber	ECE/LHT/High/Low/Kit of 2
0554563	Black	ECE/LHT/High/Low/Kit of 2

### PART # ACCESSORIES

5868171	Single Mounting Ring Kit RH
5868181	Single Mounting Ring Kit LH
8200461	2017-18 Jeep JK Mounting Ring Kit

### SINGLE HEADLIGHT

PART #	BEZEL	DESCRIPTION
0553971	Carbon Fiber	DOT/High/Low
0554541	Black	DOT/High/Low
0553981	Carbon Fiber	ECE/RHT/High/Low
0554551	Black	ECE/RHT/High/Low
0553991	Carbon Fiber	ECE/LHT/High/Low
0554561	Black	ECE/LHT/High/Low

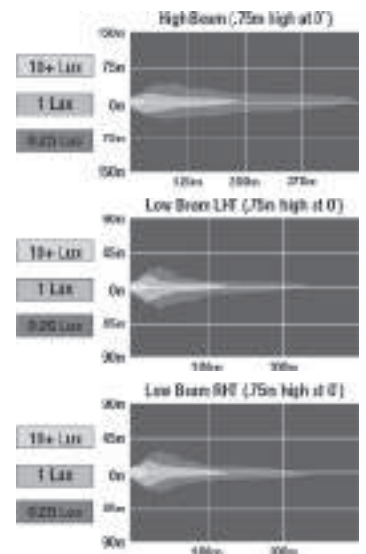



## PRODUCT SPECIFICATIONS

**Raw Lumen Output:**

2,250 (High Beam); 2,830 (Low Beam)

**Effective Lumen Output:**

898 (High Beam); 782 (Low Beam)

**Candela Output:**

73,200 (High Beam); 29,800 (Low Beam)

**Connector/Wiring:**

H4 Connector - AMP (#172615-2)

**Operating Voltage:**

9-32V DC

**Current Draw:**

Heated: 3.30A @ 12V; 1.67A @ 24V DC

Non-Heated: 2.10A @ 12V; 1.00A @ 24V DC

**Retrofit Information:**

4" x 6" Rectangle; 1A1 and 2A1 Sealed Beams

**Standards:**



LOW BEAM, HEATED



HIGH BEAM, NON-HEATED

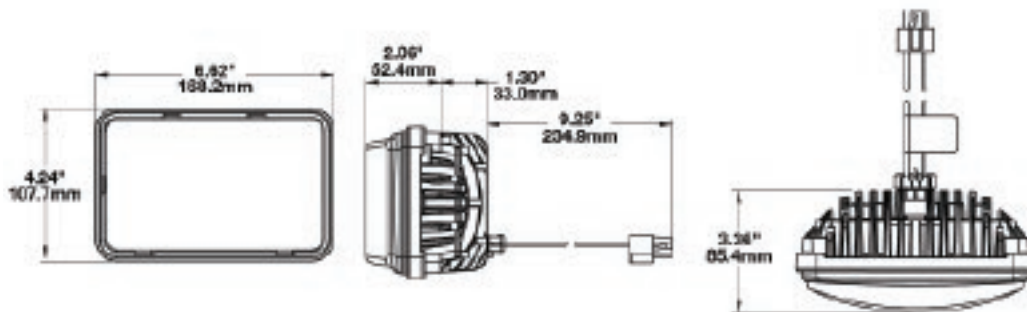

**HEATED**

PART #	BEZEL	DESCRIPTION
0552651	Black	DOT/ECE/RHT/Low
0551771	Chrome	DOT/ECE/RHT/Low
0552661	Black	ECE/LHT/Low
0552091	Chrome	ECE/LHT/Low
0552671	Black	DOT/ECE/High
0551781	Chrome	DOT/ECE/High

**NON-HEATED**

PART #	BEZEL	DESCRIPTION
0552551	Black	DOT/ECE/RHT/Low
0551371	Chrome	DOT/ECE/RHT/Low
0552561	Black	ECE/LHT/Low
0551391	Chrome	ECE/LHT/Low
0552571	Black	DOT/ECE/High
0551381	Chrome	DOT/ECE/High

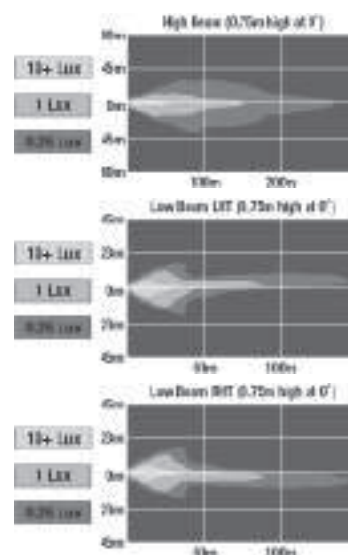

# 8900 EVOLUTION 2



## PRODUCT SPECIFICATIONS

### Raw Lumen Output:

2,640 (High Beam); 2,250 (Low Beam)

### Effective Lumen Output:

1,200 (High Beam); 975 (Low Beam)

### Connector/Wiring:

H4

### Operating Voltage:

10-32V DC

### Current Draw:

High Beam: 1.94A @ 12V; 1.03A @ 24V DC

Low Beam: 1.67A @ 12V; 0.87A @ 24V DC

Front Position: 0.22A @ 12V; 0.16A @ 24V DC

### Retrofit Information:

5" x 7" Rectangle; 2B1 Sealed Beams

### Standards:

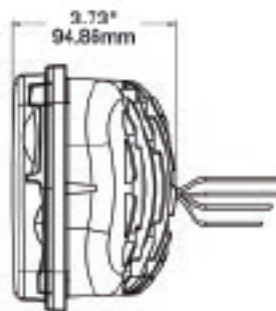
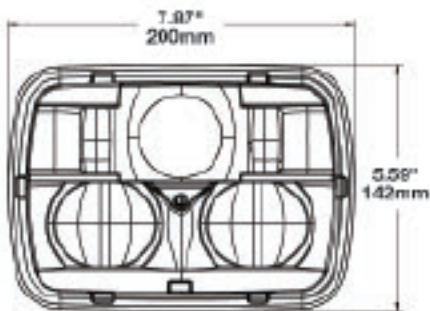

PART #	BEZEL	DESCRIPTION
0554491	Black	DOT/ECE/RHT/High/Low/FP
0554471	Chrome	DOT/ECE/RHT/High/Low/FP
0554451	Black	ECE/LHT/High/Low/FP
0554431	Chrome	ECE/LHT/High/Low/FP

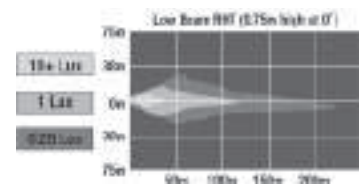
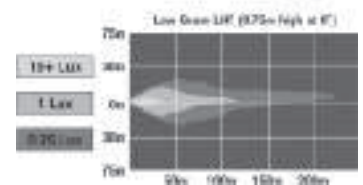
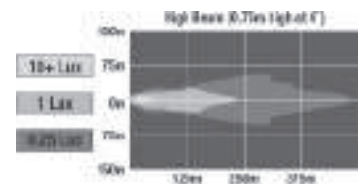

If your vehicle is operated in the United States you do NOT need to connect the Front Position wire (red) unless your vehicle is equipped with a front position light.

## PRODUCT SPECIFICATIONS

### Raw Lumen Output:

3,015 (High Beam); 2,250 (Low Beam)

### Effective Lumen Output:

1,320 (High Beam); 975 (Low Beam)

### Connector/Wiring:

H4

### Operating Voltage:

10-32V DC

### Current Draw:

High Beam: 5.35A @ 12V; 2.50A @ 24V DC

Low Beam: 4.30A @ 12V; 2.10A @ 24V DC

Front Position: 2.80A @ 12V; 1.32A @ 24V DC

### Retrofit Information:

5" x 7" Rectangle; 2B1 Sealed Beams

### Standards:

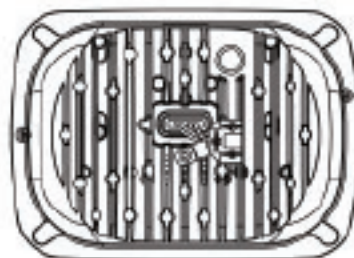
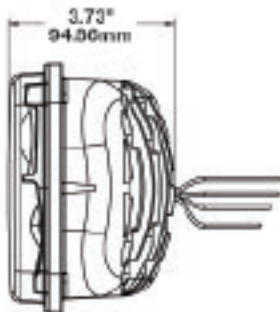
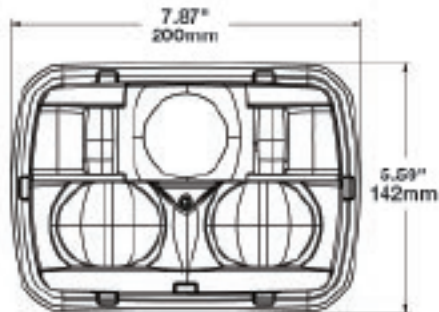

PART #	BEZEL	DESCRIPTION
0554461	Chrome	DOT/ECE/RHT/High/Low/FP
0554481	Black	DOT/ECE/RHT/High/Low/FP
0554421	Chrome	ECE/LHT/High/Low/FP
0554441	Black	ECE/LHT/High/Low/FP

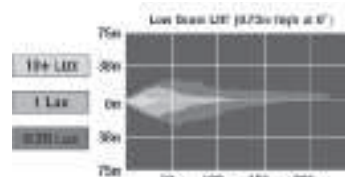
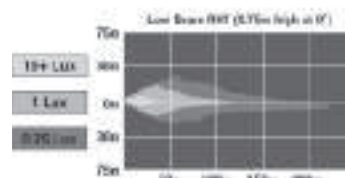
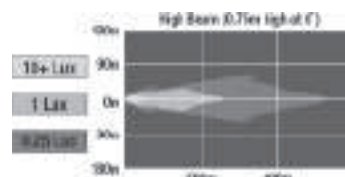

If your vehicle is operated in the United States you do NOT need to connect the Front Position wire (red) unless your vehicle is equipped with a front position light.





TRANSPORT

# MODEL 93



## PRODUCT SPECIFICATIONS

### Raw Lumen Output:

630 (High Beam); 1,910 (Low Beam)

### Effective Lumen Output:

230 (High Beam); 575 (Low Beam)

### Candela Output:

45,000 (High Beam); 18,500 (Low Beam)

### Connector/Wiring:

High Beam: Deutsch DT04-3P

Low Beam: Deutsch DT04-2P

### Operating Voltage:

10-31V DC

### Current Draw:

Low Beam: 1.97A @ 12V; 0.98A @ 24V DC

High Beam: 0.80A @ 12V; 0.40A @ 24V DC

Front Position: 0.40 @ 12V; 0.20 @ 24V DC

### Retrofit Information:

Standard 90mm lamps

### Standards:

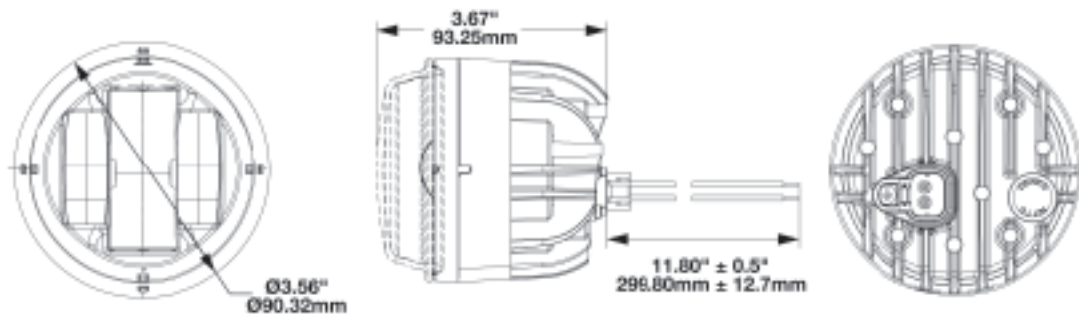

PART #	DESCRIPTION
0553081	SAE/ECE/Reg113/Low
0553091	ECE/LHT/Reg112/Low
0553101	DOT/ECE/RHT/Reg112/Low
0553071	DOT/ECE/High
0554381	SAE/ECE/High with FP
0556701	Fog Lamp/SAE/ECE
0347941	Turn Signal/SAE/ECE/DRL

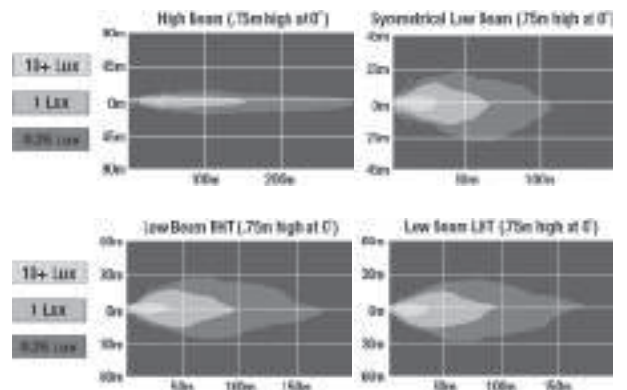

PART #	ACCESSORIES
8001601	Single Lamp Pedestal Mount Bracket
8001461	1.5mm 3-Point Mount
8001471	3.0mm 3-Point Mount



# MODEL 95

## PRODUCT SPECIFICATIONS

### Raw Lumen Output:

630 (High Beam) ; 1,435 (Fog Beam)

### Effective Lumen Output:

230 (High Beam); 607 (Fog Beam)

### Candela Output:

45,000 (High Beam); 7,500 (Fog Beam)

### Connector/Wiring:

Packard #12162000

### Operating Voltage:

10-30V DC

### Current Draw:

High Beam: 0.80A @ 12V; 0.40A @ 24V DC

Fog Beam: 1.25A @ 12V; 0.70A @ 24V DC

### Retrofit Information:

2013-2015 Peterbilt 579

2011-2015 Peterbilt 587

2008-2015 Kenworth T660

### Standards:

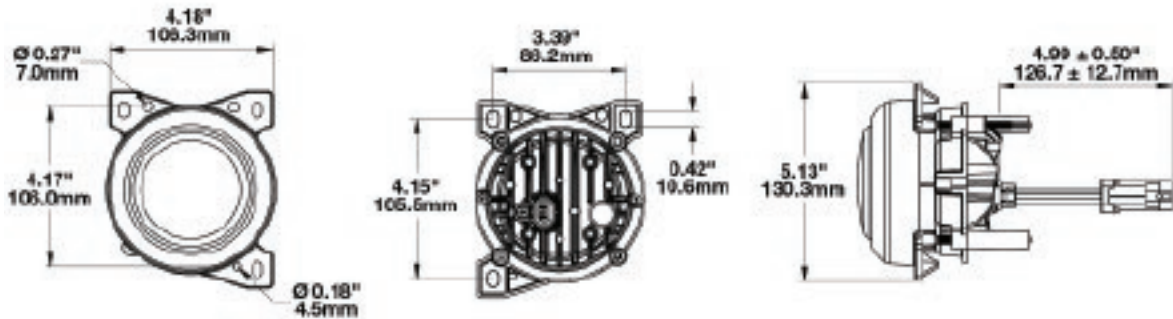

### PART # DESCRIPTION

0553721	DOT/ECE/High
0553713	DOT/ECE/High/Kit of 2
0553741	SAE/ECE/Fog
0553733	SAE/ECE/Fog/Kit of 2

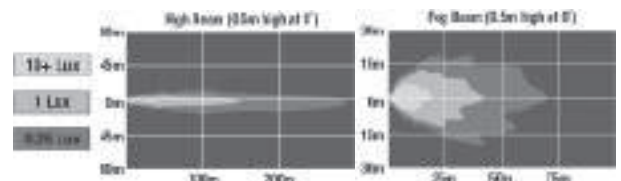

# MODEL 97



## PRODUCT SPECIFICATIONS

### Raw Lumen Output:

1,800 (High Beam); 1,600 (Low Beam)

### Effective Lumen Output:

497 (High Beam); 321 (Low Beam)

### Candela Output:

41,800 (High Beam); 14,600 (Low Beam)

### Connector/Wiring:

Deutsch DT04-4P

### Operating Voltage:

10-32V DC

### Current Draw:

High Beam: 1.8A @ 12V; 1.0A @ 24V DC

Low Beam: 1.5A @ 12V; 0.8A @ 24V DC

Front Position: 0.1A @ 12V; 0.06A @ 24V DC

### Retrofit Information:

100mm Bi-LED Headlamp

### Standards:

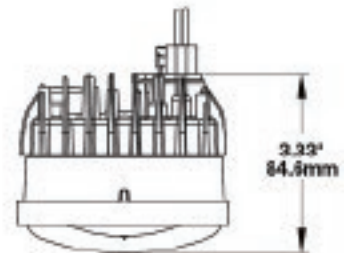
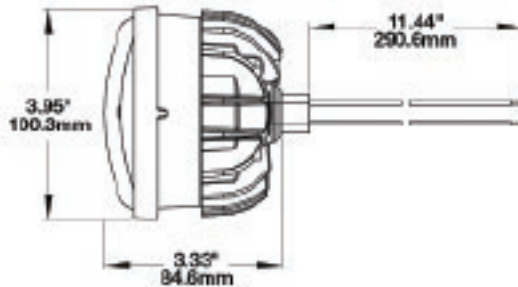

PART #	DESCRIPTION
0554831	DOT/ECE/RHT/High/Low/Reg 112
0554911	ECE/LHT/High/Low/Reg 112
0554921	DOT/ECE/High/Low/Reg 113

PART #	MOUNTING OPTIONS
8001511	3-Point Mount for 3mm Mounting Frame
8001521	Single Lamp Pedestal Mount Bracket



8001511



8001521

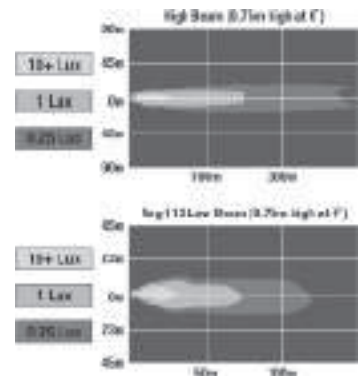



# MODEL 791

## PRODUCT SPECIFICATIONS

### Raw Lumen Output:

1,820 (Driving/Flood); 800 (Fog)

### Effective Lumen Output:

1,200 (Driving/Flood); 250 (Fog)

### Candela Output:

6,700 (Fog)

### Connector/Wiring:

Driving/Flood: Deutsch DT04-2P

Fog: Integrated 2-Pin Deutsch Connector

### Operating Voltage:

Driving/Flood: 9-32V DC

Fog: 10-18V DC

### Current Draw:

Driving/Flood: 1.27A @ 12V; 0.78A @ 24V DC

Fog: 0.55A @ 10V; 0.88A @ 12V; 1.10A @ 18V DC

### Retrofit Information:

6" x 2" Rectangle

### Standards:



FOG



DRIVING



FLOOD

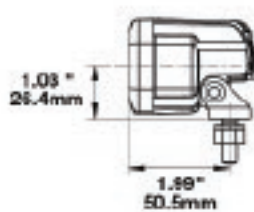
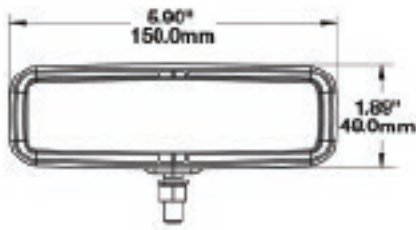

### PART # DESCRIPTION

1603511	Driving
1603521	Driving Light with Flood Beam Pattern
1603601	SAE/ECE/Fog
1603603	SAE/ECE/Fog/Kit of 2

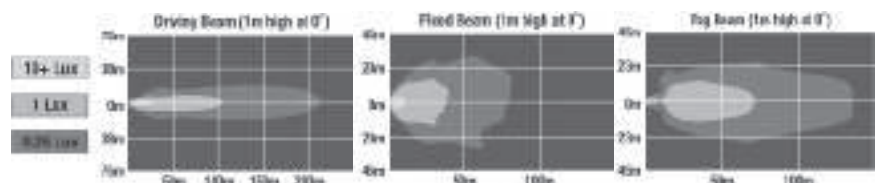

# MODEL 6045 FOG LIGHT

## PRODUCT SPECIFICATIONS



**Raw Lumen Output:**  
750

**Effective Lumen Output:**  
500

**Connector/Wiring:**  
Packard (#12059450-B)

**Operating Voltage:**  
9-18V DC

**Current Draw:**  
0.75A @ 12V DC

**Retrofit Information:**  
4.5" Round

**Standards:**

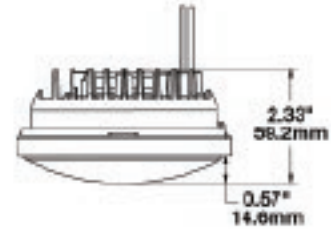
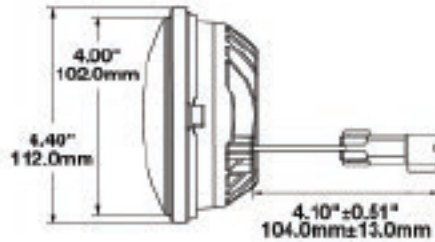

PART #	BEZEL	DESCRIPTION
0546161	Chrome	SAE/ECE/Fog
0545731	Black	SAE/ECE/Fog
0551593	Chrome	SAE/ECE/Fog/Kit of 2
0551583	Black	SAE/ECE/Fog/Kit of 2
0551653	Chrome	SAE/ECE/Fog/with #8200181

PART #	ACCESSORIES
8200181	Chrome Mounting Adapter Kit

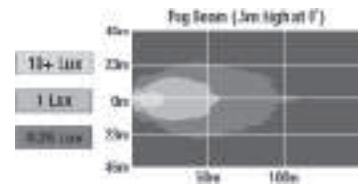

## PRODUCT SPECIFICATIONS

**Raw Lumen Output:**

1,280 (Spot/Driving Beam); 800 (Fog Beam)

**Effective Lumen Output:**

520 (Spot Beam); 430 (Driving Beam); 250 (Fog Beam)

**Candela Output:**

8,600 (Spot Beam); 3,000 (Driving Beam)

**Connector/Wiring:**

Bare Leads

**Operating Voltage:**

Driving Beam & Spot Beam: 9-32V DC

Fog Beam: 9-18V DC

**Current Draw:**

1.2A @ 12V; 0.6A @ 24V DC

**Retrofit Information:**

2" x 5" Rectangle

**Standards:**



DRIVING



FOG

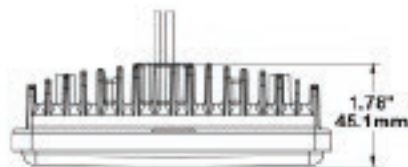
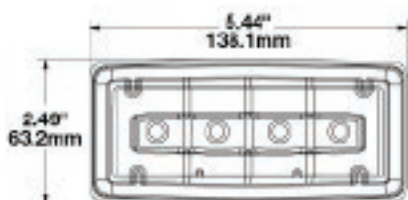

PART #	DESCRIPTION
0543591	Driving
0548631	Spot
0549691	SAE/ECE/Fog

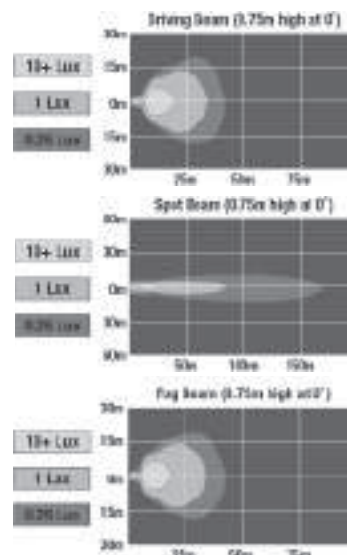

# MODEL 8630 & 8631 EVOLUTION



8630 with DRL

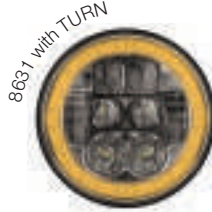

8631 with TURN



8630 DOT, NO DRL



## PRODUCT SPECIFICATIONS

### Raw Lumen Output:

2,925 (High Beam); 2,025 (Low Beam)

### Effective Lumen Output:

1,000 (High Beam); 630 (Low Beam)

### Candela Output:

61,684 (High Beam); 19,162 (Low Beam)

### Connector/Wiring:

Integral Connector in Housing simulating Delphi #12124107

### Operating Voltage:

10-32V DC

### Current Draw:

Low Beam: 2.20A @12V; 1.70A @14V; 1.10A @24V

High Beam: 3.50A @12V; 2.70A @14V; 1.70A @24V

Turn: 1.40A @12V; .70A @24V

8630 FP: .09A @12V; .07A @14V; .04A @24V

8630 DRL: .90A @12V; .68A @14V; .38A @24V

8631 FP: .05A @12V; .05A @24V

8631 DRL: 1.10A @12V; .70A @24V

### Retrofit Information:

5.75" Round (PAR46)

### Standards:

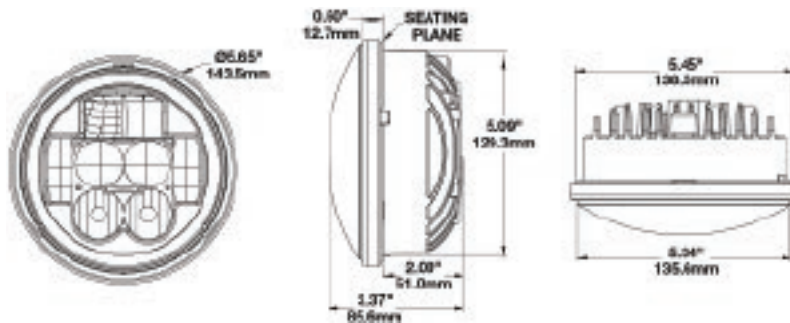

### MODEL 8630

PART #	DESCRIPTION
0549911	DOT/ECE/RHT/High/Low/FP & DRL
0549921	ECE/LHT/High/Low/FP & DRL
0550921	DOT/High/Low

### PART # ACCESSORIES

3157751	Double Lamp Mounting Ring Kit
8200001	Single Lamp Mounting Ring Kit

### MODEL 8631

PART #	DESCRIPTION
0551641	ECE/LHT/High/Low/Turn/FP & DRL
0551631	DOT/ECE/RHT/High/Low/Turn/FP & DRL

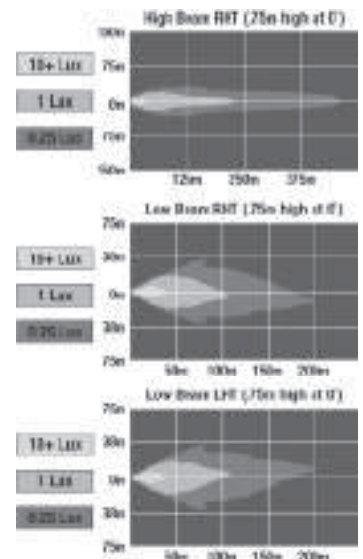

If your vehicle is operated in the United States you do NOT need to connect the Front Position wire (red) unless your vehicle is equipped with a front position light.

# MODEL 8632 EVOLUTION

## PRODUCT SPECIFICATIONS

### Raw Lumen Output:

2,925 (High Beam); 2,025 (Low Beam)

### Effective Lumen Output:

1,000 (High Beam); 630 (Low Beam)

### Connector/Wiring:

Integral Connector in housing simulating Delphi 12124107

### Operating Voltage:

10-32V DC

### Current Draw:

High Beam: 3.67A @ 12V; 1.83A @ 24V DC

Low Beam: 2.5A @ 12V; 1.25A @ 24V DC

DRL: 0.067A @ 12V; 0.34A @ 24V DC

Front Turn: 0.83A @ 12V; 0.42A @ 24V DC

Front Position: 0.08A @ 12V; 0.042A @ 24V DC

Side Marker: 0.08A @ 12V; 0.042A @ 24V DC

### Retrofit Information:

5.75" Round (PAR46) Pedestal Lights

### Standards:

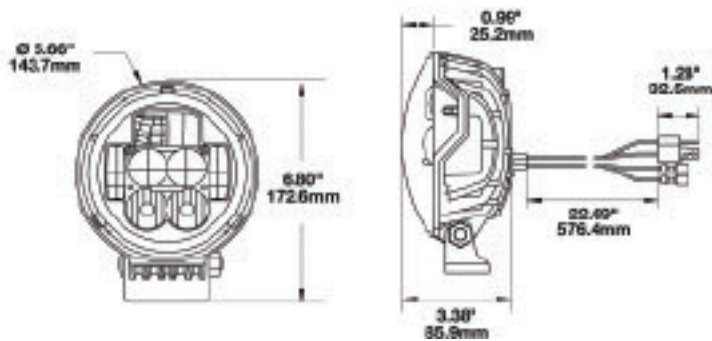

### PART # DESCRIPTION

PART #	DESCRIPTION
0551983	DOT/ECE/RHT/High/Low/Turn/FP & DRL/Kit of 2
0551561	DOT/ECE/RHT/High/Low/Turn/FP & DRL - RH Lamp
0551571	DOT/ECE/RHT/High/Low/Turn/FP & DRL - LH Lamp
0551973	ECE/LHT/High/Low/Turn/FP & DRL/Kit of 2
0551991	ECE/LHT/High/Low/Turn/FP & DRL - RH Lamp
0552001	ECE/LHT/High/Low/Turn/FP & DRL - LH Lamp

\*RH & LH refer to right hand and left hand lamps on the vehicle.

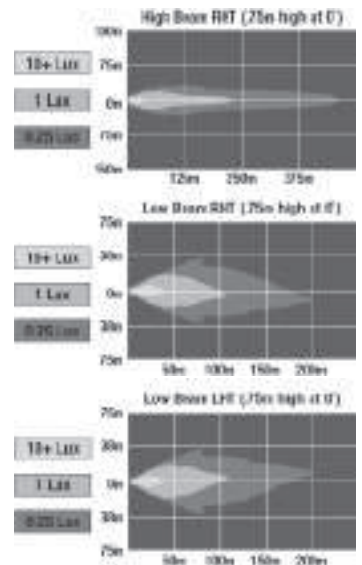

If your vehicle is operated in the United States you do NOT need to connect the Front Position wire (red) unless your vehicle is equipped with a front position light.

# 8700 EVO 2 DUAL BURN



## PRODUCT SPECIFICATIONS

### Raw Lumen Output:

3,200 (High Beam); 1,770 (Low Beam)

### Effective Lumen Output:

1,260 (High Beam); 750 (Low Beam)

### Candela Output:

71,500 (High Beam); 35,003 (Low Beam)

### Connector/Wiring:

H4

### Operating Voltage:

9-32V DC

### Current Draw:

Heated High Beam: 4.20A @ 12V; 2.30A @ 24V DC

High Beam: 3.50A @ 12V; 1.80A @ 24V DC

Low Beam: 2.00A @ 12V; 1.10A @ 24V DC

Front Position: 0.16A @ 12V; 0.10A @ 24V DC

DRL: 1.60A @ 12V; 0.80A @ 24V DC

### Retrofit Information:

7" Round (PAR56)

### Standards:

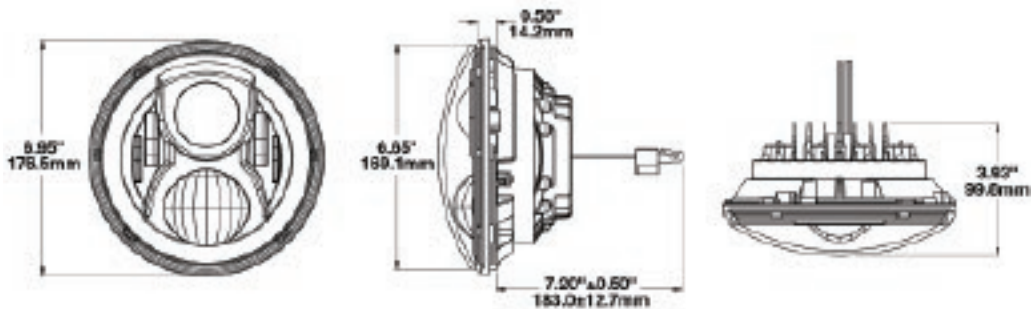

### HEATED

PART #	BEZEL	DESCRIPTION
0556281	Black	DOT/High/Low
0556291	Chrome	DOT/High/Low
0556301	Black	ECE/RHT/High/Low/FP & DRL
0556311	Chrome	ECE/RHT/High/Low/FP & DRL
0556321	Black	ECE/LHT/High/Low/FP & DRL
0556331	Chrome	ECE/LHT/High/Low/FP & DRL

### NON-HEATED

PART #	BEZEL	DESCRIPTION
0554941	Black	DOT/High/Low
0554961	Chrome	DOT/High/Low

PART #	ACCESSORIES
3156561	Panel Mount Bucket Assembly
3156351	Mounting Ring Kit for 7" Round (PAR56) Headlights
3266081	Jumper Harness H4/H13
8000381	Anti-Flicker Harness H4/H4
8000311	Anti-Flicker Harness H4/H13

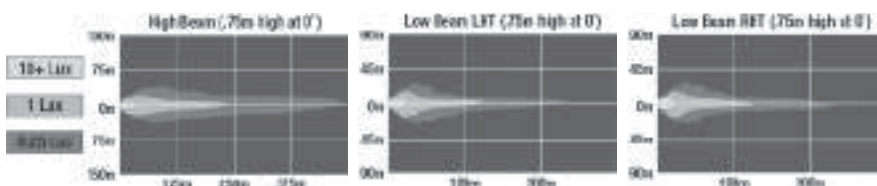

# 8700 EVO 2 PRO

## PRODUCT SPECIFICATIONS

### Raw Lumen Output:

4,170 (High Beam); 2,340 (Low Beam)

### Effective Lumen Output:

1,340 (High Beam); 694 (Low Beam)

### Candela Output:

84,700 (High Beam); 30,600 (Low Beam)

### Connector/Wiring:

H4

### Operating Voltage:

9-32V DC

### Current Draw:

High Beam: 3.60A @ 12V; 1.80A @ 24V DC  
 Low Beam: 2.00A @ 12V; 1.10A @ 24V DC  
 Front Position: 0.16A @ 12V; 0.10A @ 24V DC  
 DRL: 1.60A @ 12V; 0.80A @ 24V DC

### Retrofit Information:

7" Round (PAR56)

### Standards:

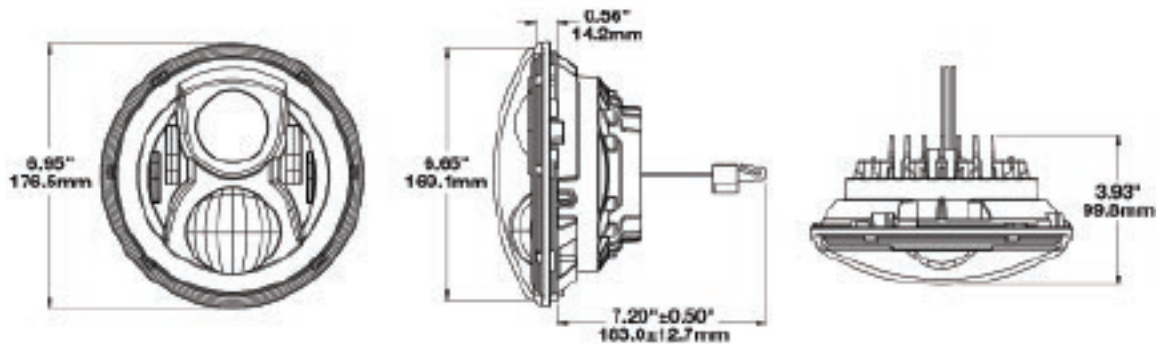

PART #	BEZEL	DESCRIPTION
0556981	Black	ECE/RHT/High/Low/FP & DRL
0556971	Chrome	ECE/RHT/High/Low/FP & DRL
0556961	Black	ECE/LHT/High/Low/FP & DRL
0556951	Chrome	ECE/LHT/High/Low/FP & DRL

PART #	ACCESSORIES
3156561	Panel Mount Bucket Assembly
3156351	Mounting Ring Kit for 7" Round (PAR56) Headlights
3266081	Jumper Harness H4/H13
8000381	Anti-Flicker Harness H4/H4
8000311	Anti-Flicker Harness H4/H13

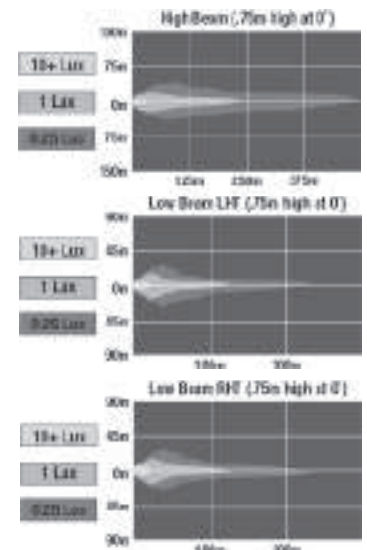





# MODEL 8710

## PRODUCT SPECIFICATIONS

**Raw Lumen Output:**  
3,300

**Effective Lumen Output:**  
1,440

**Candela Output:**  
133,000

**Connector/Wiring:**  
H4

**Operating Voltage:**  
9-32V DC

**Current Draw:**  
4.80A @ 12V DC  
2.50A @ 24V DC

**Retrofit Information:**  
7" Round (PAR56)

**Standards:**

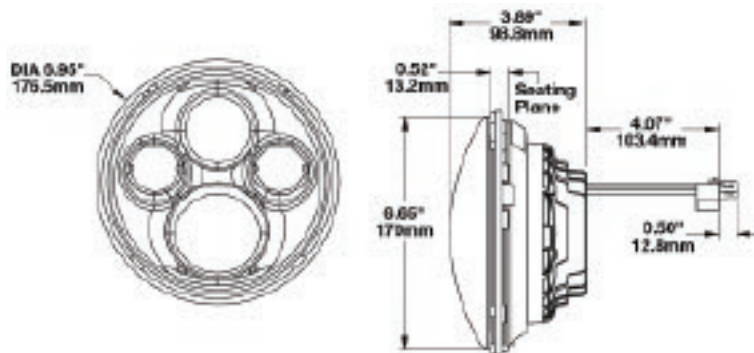

PART #	BEZEL	DESCRIPTION
0550011	Chrome	ECE/RHT/LHT/High
0550021	Black	ECE/RHT/LHT/High

PART #	ACCESSORIES
3156561	Panel Mount Bucket Assembly
3156351	Mounting Ring Kit for 7" Round (PAR56) Headlights
3266081	Jumper Harness H4/H13

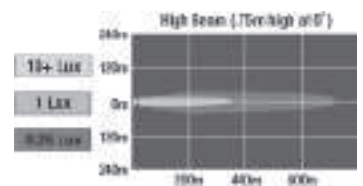

## PRODUCT SPECIFICATIONS



HIGH BEAM, NON-HEATED

LOW BEAM, HEATED



**Raw Lumen Output:**

2,250 (High Beam); 2,830 (Low Beam)

**Effective Lumen Output:**

898 (High Beam); 782 (Low Beam)

**Candela Output:**

73,200 (High Beam); 29,800 (Low Beam)

**Connector/Wiring:**

H4 Connector - AMP (#172615-2)

**Operating Voltage:**

9-32V DC

**Current Draw:**

Heated: 3.30A @ 12V; 1.67A @ 24V DC

Non-Heated: 2.10A @ 12V; 1.00A @ 24V DC

**Retrofit Information:**

4" x 6" Rectangle; 1A1 and 2A1 Sealed Beams

**Standards:**

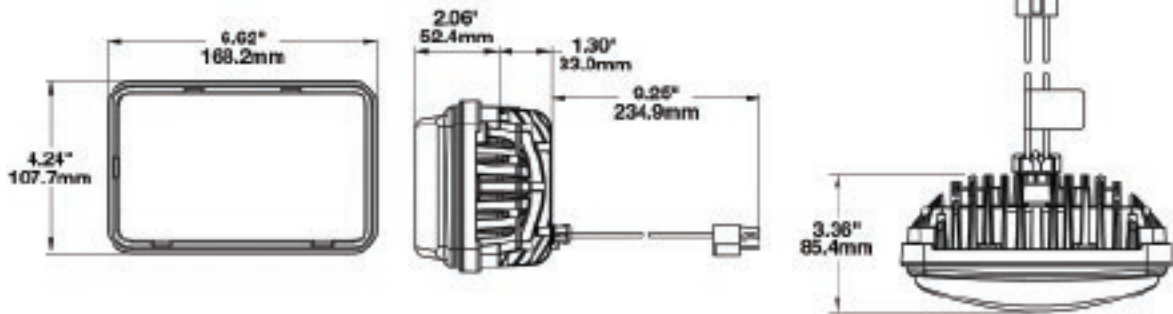

**HEATED**

PART #	BEZEL	DESCRIPTION
0551771	Chrome	DOT/ECE/RHT/Low
0552651	Black	DOT/ECE/RHT/Low
0552091	Chrome	ECE/LHT/Low
0552661	Black	ECE/LHT/Low
0551781	Chrome	DOT/ECE/High
0552671	Black	DOT/ECE/High

**NON-HEATED**

PART #	BEZEL	DESCRIPTION
0551371	Chrome	DOT/ECE/RHT/Low
0552551	Black	DOT/ECE/RHT/Low
0551391	Chrome	ECE/LHT/Low
0552561	Black	ECE/LHT/Low
0551381	Chrome	DOT/ECE/High
0552571	Black	DOT/ECE/High

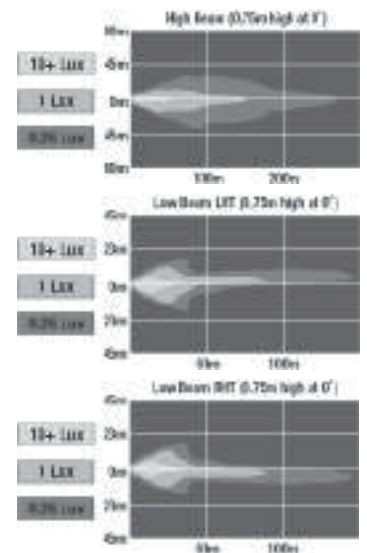

# 8801 EVOLUTION

## PRODUCT SPECIFICATIONS

**Raw Lumen Output:**  
1,890

**Effective Lumen Output:**  
890 (High Beam) 740 (Low Beam)

**Connector/Wiring:**  
AMP (#172615-2)

**Operating Voltage:**  
10-15V DC

**Current Draw:**  
2.25A @ 12V DC

**Retrofit Information:**  
4" x 6" Rectangle

**Standards:**

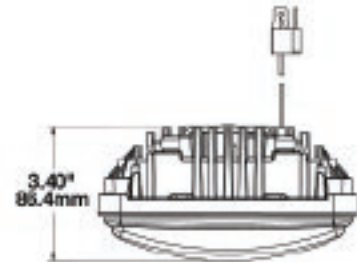
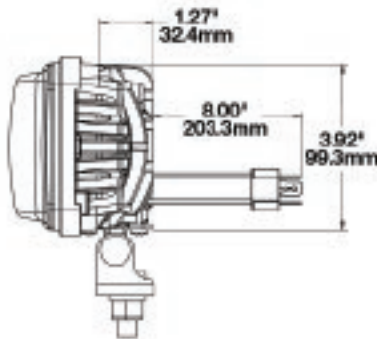
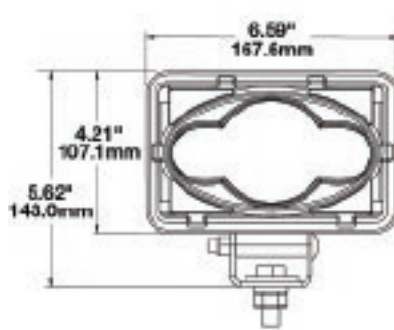

PART #	DESCRIPTION
0549211	DOT/ECE/RHT/Low
0549251	ECE/LHT/Low
0549231	DOT/ECE/RHT/High
0550433	DOT/ECE/High/Kit of 2

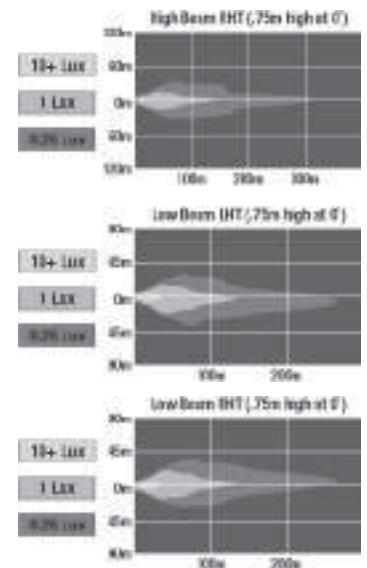

# 8900 EVOLUTION 2



## PRODUCT SPECIFICATIONS

### Raw Lumen Output:

2,640 (High Beam); 2,250 (Low Beam)

### Effective Lumen Output:

1,200 (High Beam); 975 (Low Beam)

### Connector/Wiring:

H4

### Operating Voltage:

10-32V DC

### Current Draw:

High Beam: 1.94A @ 12V; 1.03A @ 24V DC

Low Beam: 1.67A @ 12V; 0.87A @ 24V DC

Front Position: 0.22A @ 12V; 0.16A @ 24V DC

### Retrofit Information:

5" x 7" Rectangle; 2B1 Sealed Beams

### Standards:

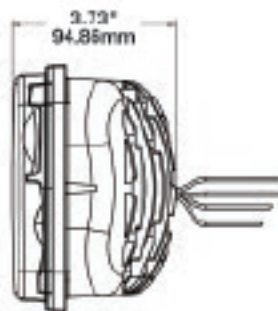
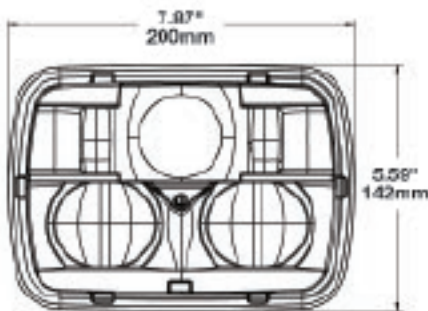

PART #	BEZEL	DESCRIPTION
0554471	Chrome	DOT/ECE/RHT/High/Low/FP
0554491	Black	DOT/ECE/RHT/High/Low/FP
0554431	Chrome	ECE/LHT/High/Low/FP
0554451	Black	ECE/LHT/High/Low/FP

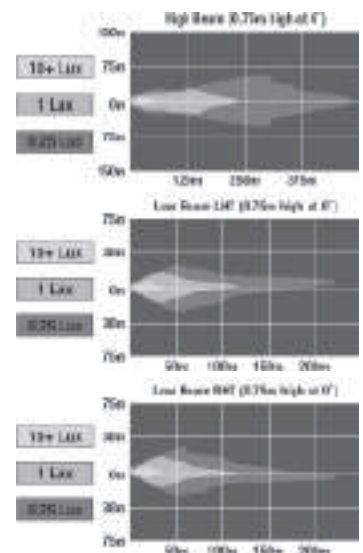

If your vehicle is operated in the United States you do NOT need to connect the Front Position wire (red) unless your vehicle is equipped with a front position light.

## PRODUCT SPECIFICATIONS

**Raw Lumen Output:**

3,015 (High Beam); 2,250 (Low Beam)

**Effective Lumen Output:**

1,320 (High Beam); 975 (Low Beam)

**Connector/Wiring:**

H4

**Operating Voltage:**

10-32V DC

**Current Draw:**

High Beam: 5.35A @ 12V; 2.50A @ 24V DC

Low Beam: 4.30A @ 12V; 2.10A @ 24V DC

Front Position: 2.80A @ 12V; 1.32A @ 24V DC

**Retrofit Information:**

5" x 7" Rectangle; 2B1 Sealed Beams

**Standards:**

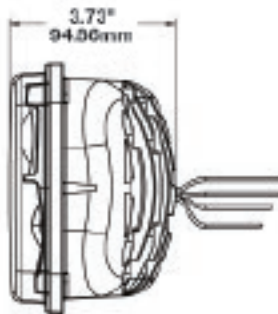
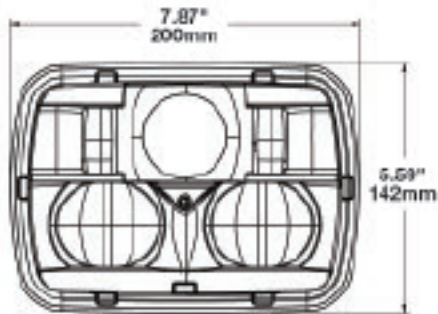

PART #	BEZEL	DESCRIPTION
0554481	Black	DOT/ECE/RHT/High/Low/FP
0554461	Chrome	DOT/ECE/RHT/High/Low/FP
0554441	Black	ECE/LHT/High/Low/FP
0554421	Chrome	ECE/LHT/High/Low/FP

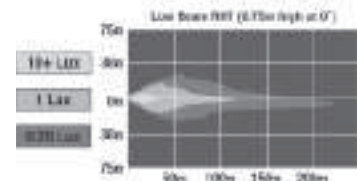
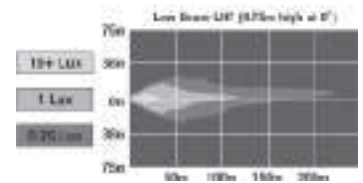
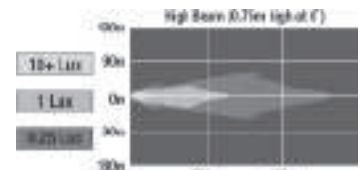

If your vehicle is operated in the United States you do NOT need to connect the Front Position wire (red) unless your vehicle is equipped with a front position light.

## PRODUCT SPECIFICATIONS



**Raw Lumen Output:**  
2,880 (High Beam); 2,160 (Low Beam)

**Effective Lumen Output:**  
1,150 (High Beam); 800 (Low Beam)

**Candela Output:**  
52,000 (High Beam)

**Connector/Wiring:**  
6-Pin Delphi 12052848

**Operating Voltage:**  
12V: 10-15V  
24V: 20-32V DC

**Current Draw:**  
Low Beam: 2.70A @ 12V; 1.20A @ 24V DC  
High Beam: 3.40A @ 12V; 1.60A @ 24V DC  
Turn Signal: 0.85A @ 12V; 0.27A @ 24V DC  
FP & DRL: 0.04A @ 12V; 0.03A @ 24V DC

**Retrofit Information:**  
5" x 11" Rectangle; Pedestal Mount Headlights

**Standards:**

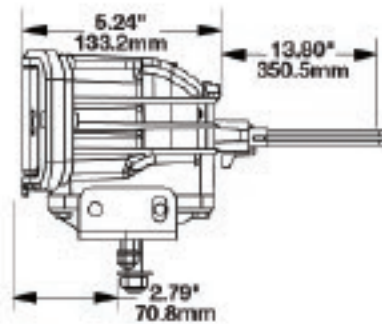
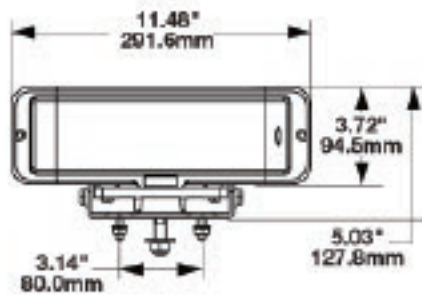

**HEATED**

PART #	DESCRIPTION
0552243	12V/DOT/High/Low/Turn/Kit of 2
0551803	24V/DOT/High/Low/Turn/Kit of 2
0552433	12V/ECE/LHT/High/Low/Turn/FP & DRL/Kit of 2
0551863	24V/ECE/LHT/High/Low/Turn/FP & DRL/Kit of 2
0552423	12V/ECE/RHT/High/Low/Turn/FP & DRL/Kit of 2
0551833	24V/ECE/RHT/High/Low/Turn/FP & DRL/Kit of 2

**NON-HEATED**

PART #	DESCRIPTION
0550061	12-24V/DOT/High/Low/Turn/Kit of 2
0550161	12-24V/ECE/RHT/High/Low/Turn/FP & DRL/Kit of 2
0550171	12-24V/ECE/LHT/High/Low/Turn/FP & DRL/Kit of 2

If your vehicle is operated in the United States you do NOT need to connect the Front Position wire (red) unless your vehicle is equipped with a front position light.

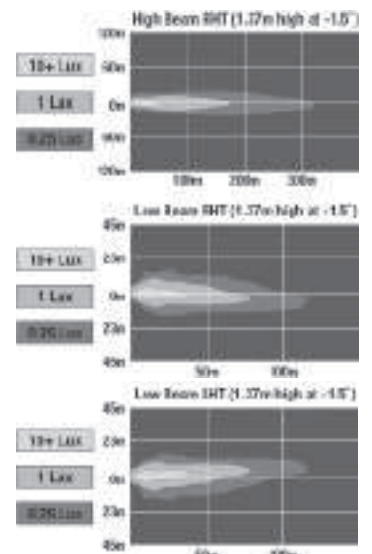

## PRODUCT SPECIFICATIONS

**Raw Lumen Output:**

2,880 (High Beam); 2,160 (Low Beam)

**Effective Lumen Output:**

1,150 (High Beam); 800 (Low Beam)

**Candela Output:**

52,000 (High Beam)

**Connector/Wiring:**

6-Pin Delphi 12052848

**Operating Voltage:**

12-24V DC

**Current Draw:**

Low Beam: 1.75A @ 12V; 1.00A @ 24V DC

High Beam: 2.50A @ 12V; 1.50A @ 24V DC

Turn: .750A @ 12V DC; .280A @ 24V DC

Front Position: .040A @ 12V DC; .025A @ 24V DC

Heater: 2.00A @ 12V DC; 1.75A @ 24V DC

**Retrofit Information:**

5" x 11" Rectangle; Pedestal Mount Headlights

**Standards:**

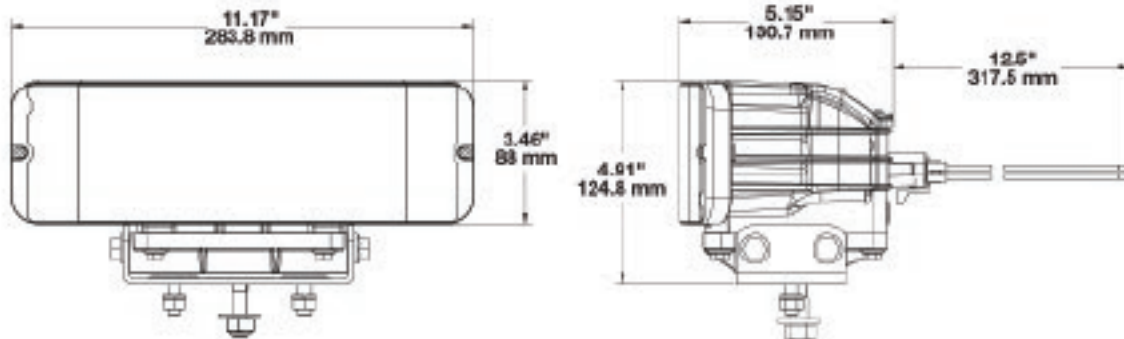
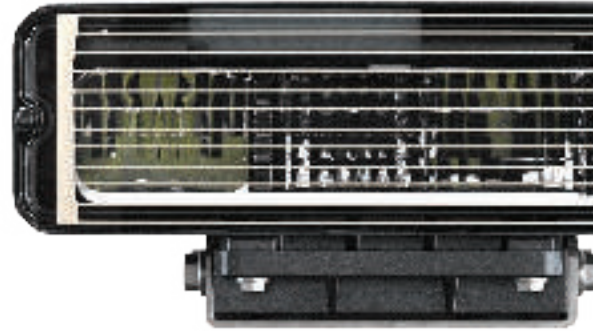

**PART # DESCRIPTION**

0555743 12-24V DOT/High/Low/Turn/FP/Kit of 2

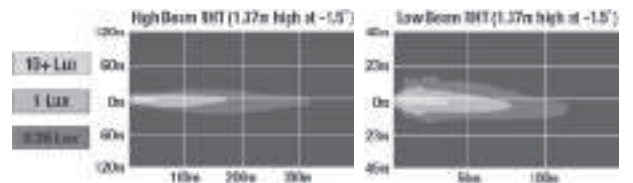

If your vehicle is operated in the United States you do NOT need to connect the Front Position wire (red) unless your vehicle is equipped with a front position light.



## PRODUCT SPECIFICATIONS

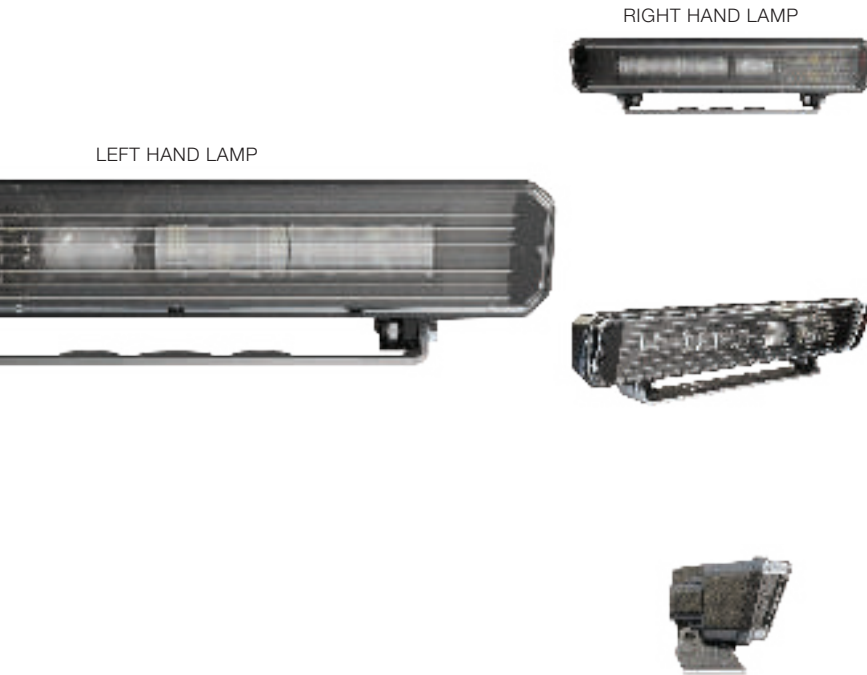

**Raw Lumen Output:**  
2370 (Low Beam); 4300 (High Beam)

**Effective Lumen Output:**  
587 (Low Beam); 1060 (High Beam)

**Candela Output:**  
58,000 (High Beam)

**Connector/Wiring:**  
6-Pin Delphi 12052848

**Operating Voltage:**  
9-30V DC

**Current Draw:**  
Low Beam: 3.50A @ 12V; 2.25A @ 24V DC  
High Beam: 5.00A @ 12V; 3.00A @ 24V DC  
Turn: 1.20A @ 12V DC; .75A @ 24V DC  
Front Position: 2.00A @ 12V DC; 1.50A @ 24V DC  
DRL: 2.50A @ 12V DC; 1.75A @ 24V DC

**Retrofit Information:**  
3" x 13" Rectangle; Pedestal Mount Headlights

**Standards:**

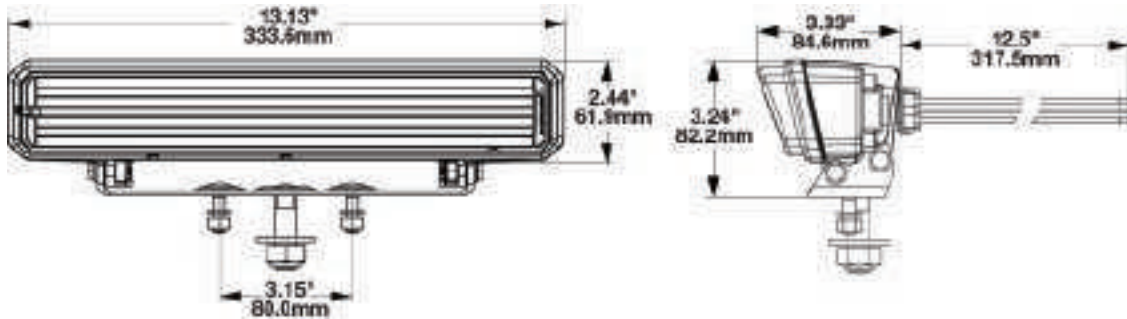

PART #	DESCRIPTION
0556273	DOT/ECE/RHT/High/Low/Turn/FP & DRL/Kit of 2
0556383	ECE/LHT/High/Low/Turn/FP& DRL/Kit of 2

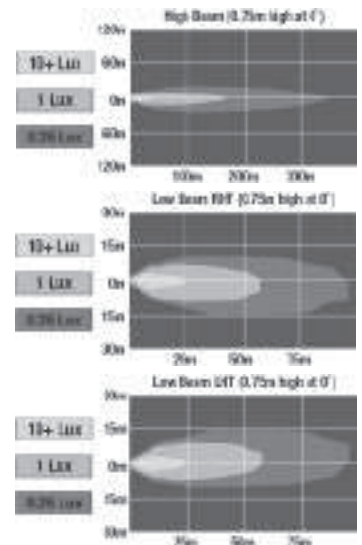

If your vehicle is operated in the United States you do NOT need to connect the Front Position wire (red) unless your vehicle is equipped with a front position light.









# SMARTHEAT®

## DON'T LET SNOW AND ICE SLOW YOU DOWN.

Winter weather can cause snow and ice build up on the outside of lights, reducing visibility. This creates a dangerous situation not only for you, but to others as well.

J.W. Speaker's series of heated LED lights with SmartHeat® is redefining lighting with its integrated lens heater technology. Each light is designed to automatically de-ice the surface of the lens. Products with SmartHeat provide peace of mind during cold and snowy conditions by maintaining your ability to see, and to be seen by other drivers.

**SmartHeat Technology** uses an internal sensor for air and light temperature and automatically turns the heater on and off as needed.

		<i>Light Temperature</i>		
				
<i>Air Temperature</i>		<b>ON</b>	<b>ON</b>	OFF
		<b>ON</b>	OFF	OFF
		OFF	OFF	OFF



# A LEGACY OF INNOVATION

## OEM ORIGINS

1935

J.W. Speaker Corporation founded by John W. Speaker to manufacture tube & tire repair products



1940S

Supplied the U.S. Military during World War II, including compact folding stoves and tire repair products; Designed & patented the iconic P-38 can openers and Heatab dry fuel.

After the war, shifted focus to manufacturing mirrors and lighting products for trucks and cars.



1960S

John W. Speaker unexpectedly passed away and his son, Jack, became President.

Expanded into lighting on original equipment manufacturing (OEM) for lawn & garden and golf & turf tractors.

1980S

Tim & Jamie Speaker, grandsons of the founder John W. Speaker, formally join the company and became Co-Presidents.

J.W. Speaker became solely focused on vehicle lighting, growing the business with custom designed lighting for agriculture OEM customers



1990S

Production on first custom headlamp for Arctic Cat snowmobile began, pushing into the power sport market.

Partnerships with premier OEM customers like Harley-Davidson, U.S. military, and development on custom lighting products began.



# AND AFTERMARKET GROWTH



First LED light with solid optic technology designed, providing a pathway for future product development

2000S

International expansion and growing portfolio of OEM products in the industrial, mining, power sport, and construction markets



Harnessed experience from OEM products and entered the aftermarket with the first-of its-kind 7" round LED headlight for Jeeps

2012

Established distribution channels and expanded the company product portfolio into the aftermarket

Launched the world's first Adaptive Motorcycle Headlight™ with technology that automatically fills dark areas of the road when cornering on a bike

2015

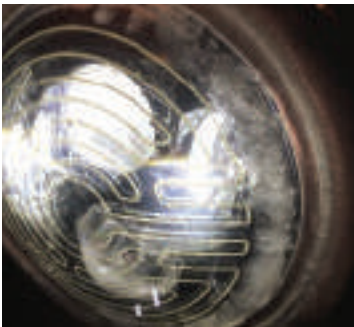

SmartHeat® technology launched in headlights and work lights with integrated lens technology to de-ice lenses, to improve driver visibility & safety

2017



Released Evo J3™ headlight and Trail 6™ off-road light, both compatible with new J-Link™ mobile app, giving drivers control and customization options for their lights

2019





**POWER SPORTS**

# MODEL 93M



## PRODUCT SPECIFICATIONS

### Raw Lumen Output:

1,910 (Low Beam); 630 (High Beam)

### Effective Lumen Output:

575 (Low Beam); 230 (High Beam)

### Candela Output:

18,000 (Low Beam); 45,000 (High Beam)

### Connector/Wiring:

High Beam: Deutsch DT04-3P

Low Beam: Deutsch DT04-2P

### Operating Voltage:

10.5-38V DC

### Current Draw:

Low Beam: 1.97A @ 12V; 0.98A @ 24V DC

High Beam: 0.80A @ 12V; 0.40A @ 24V DC

Front Position: 0.40A @ 12V; 0.20A @ 24V DC

### Retrofit Information:

Pedestal Mount for Fat Bob® & Custom Motorcycles

### Standards:

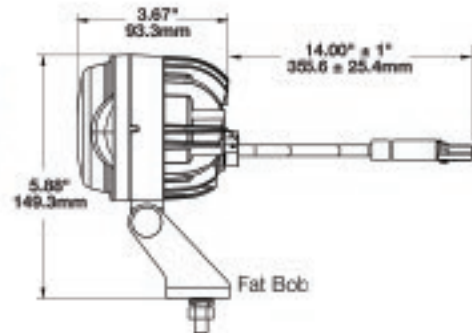
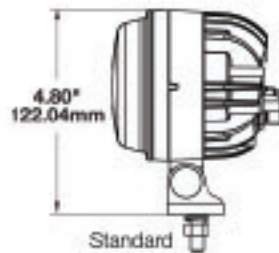

## PART # DESCRIPTION

0555911 DOT/ECE/High/Low/Kit of 2

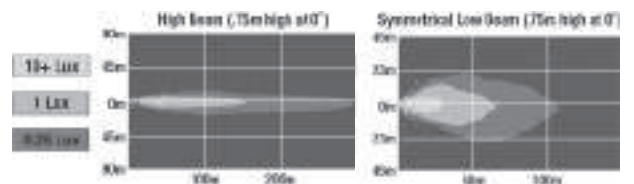

If your bike is operated in the United States you do NOT need to connect the Front Position wire (red) unless your bike is equipped with a front position light.

Fat Bob is a registered trademark of H-D U.S.A., LLC



## PRODUCT SPECIFICATIONS

### Raw Lumen Output:

1,800 (High Beam); 1,600 (Low Beam)

### Effective Lumen Output:

497 (High Beam); 321 (Low Beam)

### Candela Output:

41,800 (High Beam); 14,600 (Low Beam)

### Connector/Wiring:

Deutsch DT04-4P

### Operating Voltage:

10-32V DC

### Current Draw:

High Beam: 1.8A @ 12V; 1.0A @ 24V DC

Low Beam: 1.5A @ 12V; 0.8A @ 24V DC

Front Position: 0.1A @ 12V; 0.06A @ 24V DC

### Retrofit Information:

Standard 100mm Bi-LED Headlamp

### Standards:

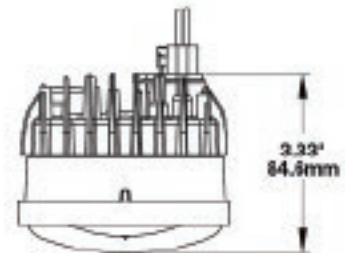
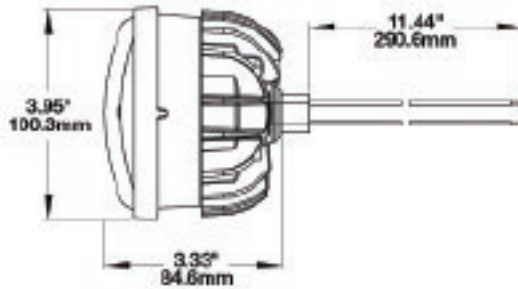

### PART # DESCRIPTION

0554831 DOT/ECE/RHT/High/Low/Reg 112

0554911 ECE/LHT/High/Low/Reg 112

0554921 DOT/ECE/High/Low/Reg 113

### PART # MOUNTING OPTIONS

8001521 Single Lamp Pedestal Mount Bracket

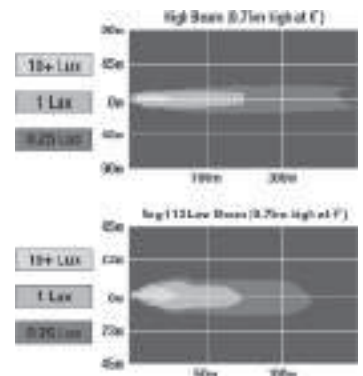

# MODEL 6025 FOG LIGHT



## PRODUCT SPECIFICATIONS

**Raw Lumen Output:**  
346

**Effective Lumen Output:**  
291

**Candela Output:**  
12,300

**Connector/Wiring:**  
Packard 12059450-B

**Operating Voltage:**  
9-16V DC

**Current Draw:**  
0.83A @ 10V DC  
0.70A @ 12V DC

**Retrofit Information:**  
4.5" Round

**Standards:**

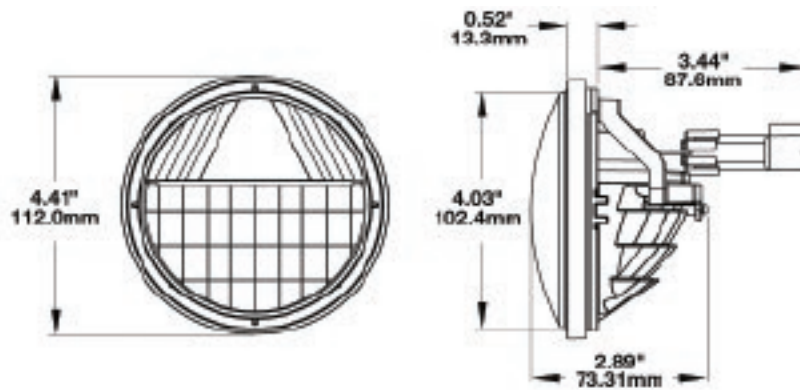

### PART # DESCRIPTION

0553021	SAE/ECE/Fog
0553023	SAE/ECE/Fog/Kit of 2

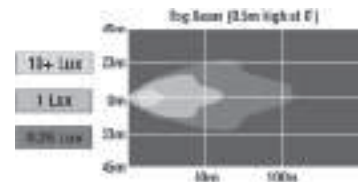



# MODEL 6045 FOG LIGHT

## PRODUCT SPECIFICATIONS

**Raw Lumen Output:**  
750

**Effective Lumen Output:**  
500

**Connector/Wiring:**  
Packard (#12059450-B)

**Operating Voltage:**  
9-18V DC

**Current Draw:**  
0.75A @ 12V DC

**Retrofit Information:**  
4.5" Round

**Standards:**

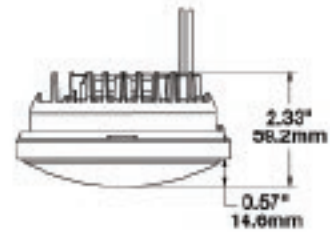
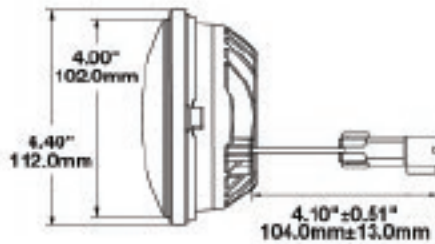

PART #	BEZEL	DESCRIPTION
0546161	Chrome	SAE/ECE/Fog
0545731	Black	SAE/ECE/Fog
0551593	Chrome	SAE/ECE/Fog/Kit of 2
0551583	Black	SAE/ECE/Fog/Kit of 2

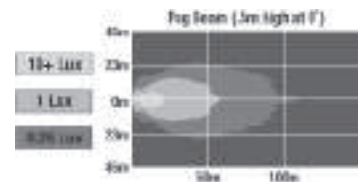

# 6130 EVOLUTION



## PRODUCT SPECIFICATIONS

### Raw Lumen Output:

2,230 (High Beam); 1,330 (Low Beam)  
1,760 (High Beam Only); 1,690 (Low Beam Only)

### Effective Lumen Output:

840 (High Beam); 440 (Low Beam)  
955 (High Beam Only); 640 (Low Beam Only)

### Connector/Wiring:

12" Bare Wires

### Operating Voltage:

10-30V DC

### Current Draw:

High Beam: 3.00A @ 12V; 1.43A @ 24V DC  
Low Beam: 2.30A @ 12V; 1.01A @ 24V DC  
Front Position: 0.12A @ 12V; 0.09A @ 24V DC  
DRL: 0.44A @ 12V; 0.24A @ 24V DC  
High Beam Only: 1.84A @ 12V; 0.84A @ 24V DC  
Low Beam Only: 2.07A @ 12V; 0.96A @ 24V DC

### Retrofit Information:

4.75" Round

### Standards:

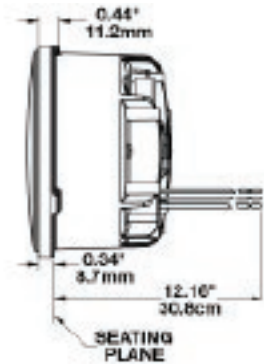
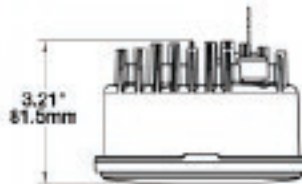
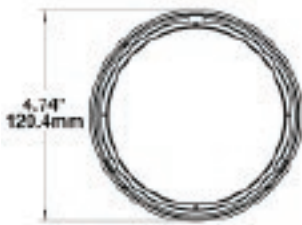

### PART # DESCRIPTION

0549871	DOT/ECE/High/FP
0549851	DOT/ECE/RHT/Low/DRL
0549881	DOT/ECE/RHT/High/Low/FP
0549861	ECE/LHT/Low
0549891	ECE/LHT/High/Low/FP

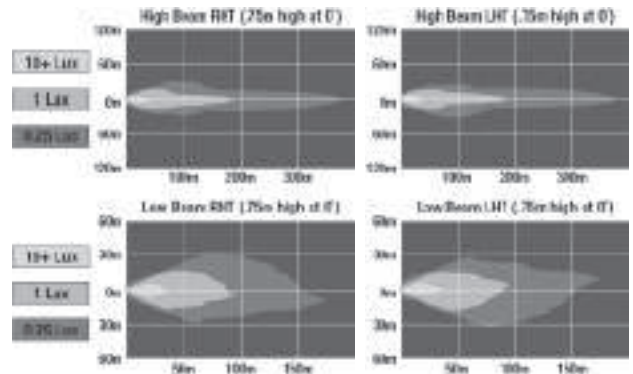

If your vehicle is operated in the United States you do NOT need to connect the Front Position wire (red) unless your vehicle is equipped with a front position light.

# 8415 EVOLUTION

## PRODUCT SPECIFICATIONS

### Raw Lumen Output:

1,075 (High Beam); 430 (Low Beam)

### Effective Lumen Output:

720 (High Beam); 240 (Low Beam)

### Connector/Wiring:

PE 12110293

### Operating Voltage:

10-30V DC

### Current Draw:

High Beam: 1.14A @ 12V; 0.57A @ 24V DC

Low Beam: 0.41A @ 12V; 0.22A @ 24V DC

### Retrofit Information:

4.5" Round (PAR36)

### Standards:



ADJUSTABLE MOUNT



### ADJUSTABLE MOUNT

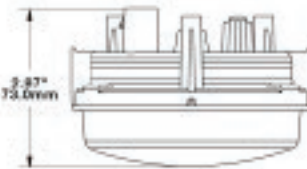
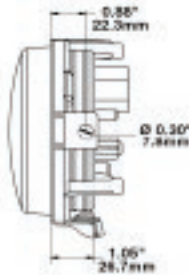
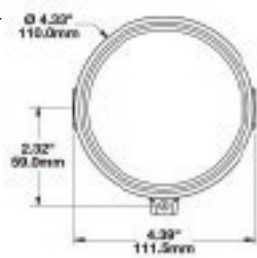

### FIXED MOUNT

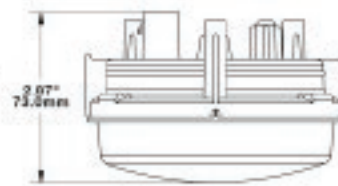
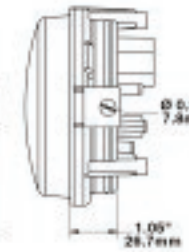
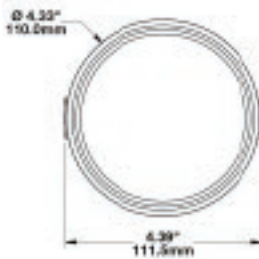

### PART # DESCRIPTION

0551191	SAE/ECE/High/Low/Adjustable Mount
0551761	SAE/ECE/High/Low/Fixed Panel Mount
0552031	SAE/ECE/High/Low/Adjustable Mount - UL Version

If your vehicle is operated in the United States you do NOT need to connect the Front Position wire (red) unless your vehicle is equipped with a front position light.

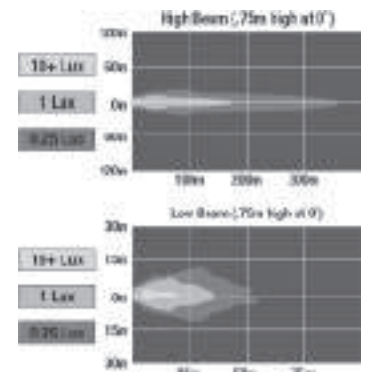

# MODEL 8620



## PRODUCT SPECIFICATIONS

### Raw Lumen Output:

1,620 (High Beam); 925 (Low Beam)

### Effective Lumen Output:

850 (High Beam); 500 (Low Beam)

### Candela Output:

41,000 (High Beam); 12,110 (Low Beam)

### Connector/Wiring:

H4

### Operating Voltage:

9-16V DC

### Current Draw:

High Beam: 2.67A @ 12V DC

Low Beam: 1.67A @ 12V DC

Front Position: 0.13A @ 12V DC

### Retrofit Information:

5.75" Round (PAR46)

### Standards:

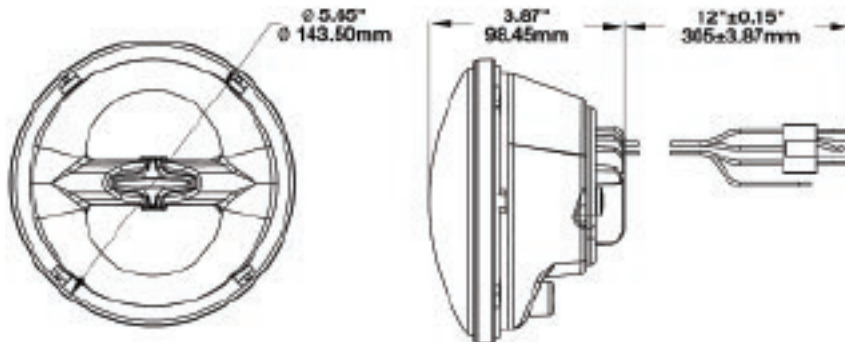

PART #	BEZEL	DESCRIPTION
--------	-------	-------------

0553011	Chrome	DOT/ECE/High/Low
---------	--------	------------------

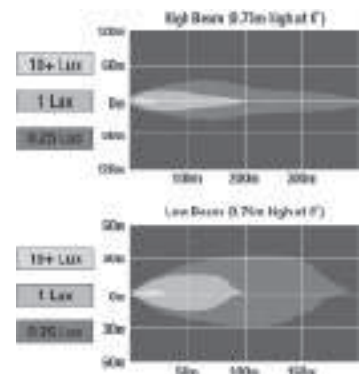

If your bike is operated in the United States you do NOT need to connect the Front Position wire (red) unless your bike is equipped with a front position light.

## PRODUCT SPECIFICATIONS

**Raw Lumen Output:**

3,520 (High Beam); 2,120 (Low Beam)

**Effective Lumen Output:**

1,600 (High Beam); 1,050 (Low Beam)

**Candela Output:**

60,000 (High Beam); 8,300 (Low Beam)

**Connector/Wiring:**

H4

**Operating Voltage:**

9-16V DC

**Current Draw:**

Low Beam: 1.9A @ 12V DC

High Beam: 3.2A @ 12V DC

Front Position: 0.21A @ 12V DC

Low Beam at Full Lean: 4.2A @ 12V DC

High Beam at Full Lean: 5.5A @ 12V DC

**Retrofit Information:**

5.75" Round (PAR46)

**Standards:**

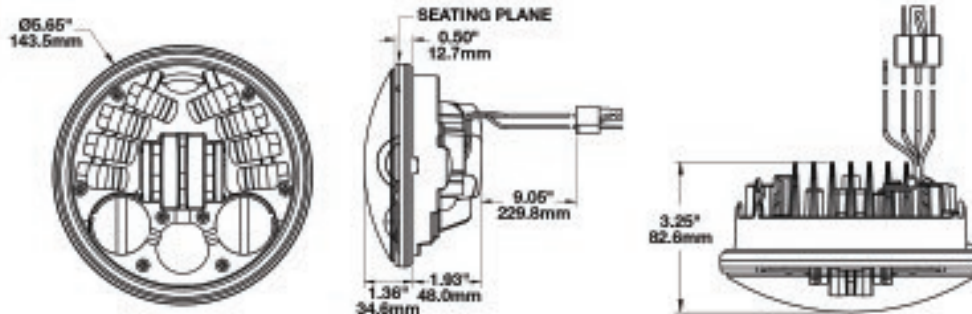
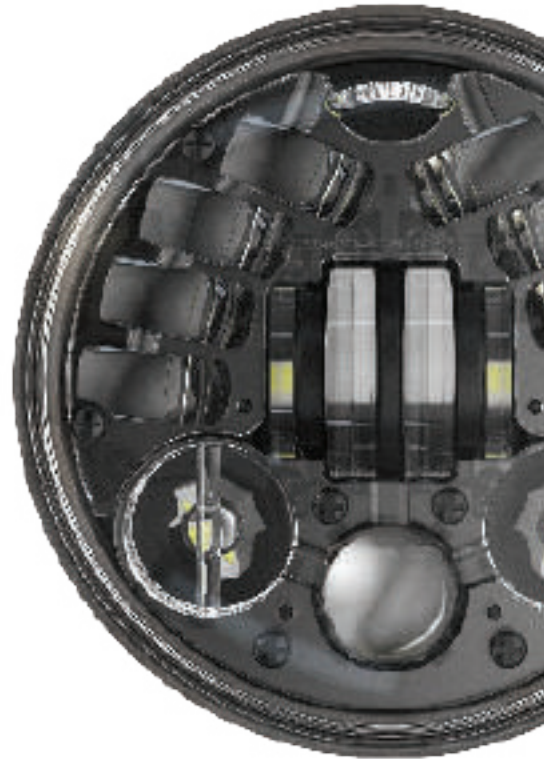

**ADAPTIVE**

PART #	BEZEL	DESCRIPTION
0555091	Black	DOT/ECE/High/Low
0555101	Chrome	DOT/ECE/High/Low

**NON-ADAPTIVE**

PART #	BEZEL	DESCRIPTION
0551681	Black	DOT/ECE/High/Low
0551731	Chrome	DOT/ECE/High/Low

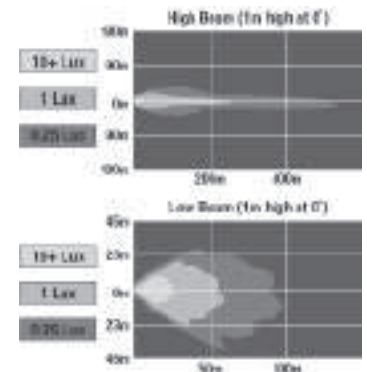

If your bike is operated in the United States you do NOT need to connect the Front Position wire (red) unless your bike is equipped with a front position light.

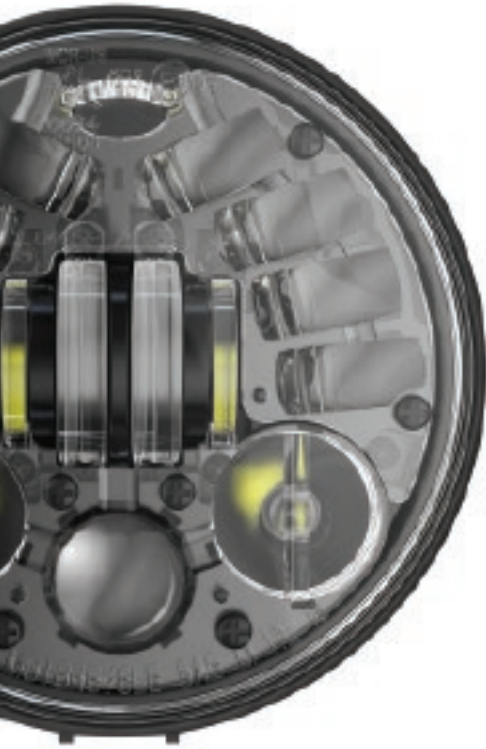

## PRODUCT SPECIFICATIONS

**Raw Lumen Output:**

3,520 (High Beam); 2,120 (Low Beam)

**Effective Lumen Output:**

1,600 (High Beam); 1,050 (Low Beam)

**Candela Output:**

60,000 (High Beam); 8,300 (Low Beam)

**Connector/Wiring:**

Bare Leads

**Operating Voltage:**

9-16V DC

**Current Draw:**

Low Beam: 1.9A @ 12V DC

High Beam: 3.2A @ 12V DC

Front Position: 0.21A @ 12V DC

Low Beam at Full Lean: 4.2A @ 12V DC

High Beam at Full Lean: 5.5A @ 12V DC

**Retrofit Information:**

5.75" Round (PAR46)

**Standards:**

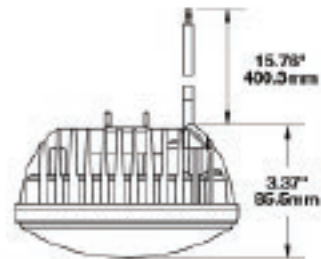
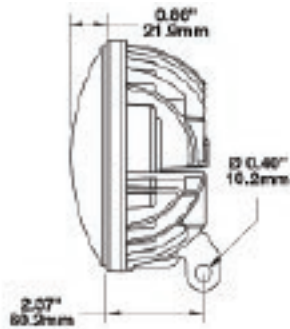

**ADAPTIVE**

PART #	BEZEL	DESCRIPTION
0555111	Black	DOT/ECE/High/Low
0555121	Chrome	DOT/ECE/High/Low

**NON-ADAPTIVE**

PART #	BEZEL	DESCRIPTION
0552011	Black	DOT/ECE/High/Low
0552021	Chrome	DOT/ECE/High/Low

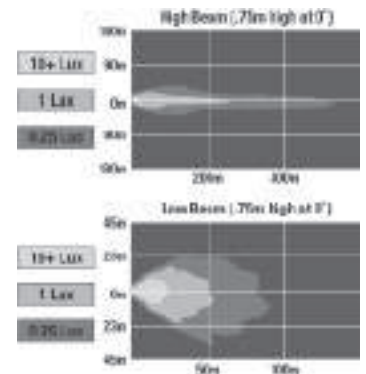

If your bike is operated in the United States you do NOT need to connect the Front Position wire (red) unless your bike is equipped with a front position light.

## PRODUCT SPECIFICATIONS

**Raw Lumen Output:**

7,020 (High Beam); 4,240 (Low Beam)

**Effective Lumen Output:**

3,200 (High Beam); 2,040 (Low Beam)

**Connector/Wiring:**

H4

**Operating Voltage:**

9-16V DC

**Current Draw:**

Low Beam: 3.8A @ 12V DC

High Beam: 6.4A @ 12V DC

Front Position: 0.42A @ 12V DC

Low Beam at Full Lean: 8.4A @ 12V DC

High Beam at Full Lean: 11.0A @ 12V DC

**Retrofit Information:**

Fits 2013 and older Road Glide models

**Standards:**

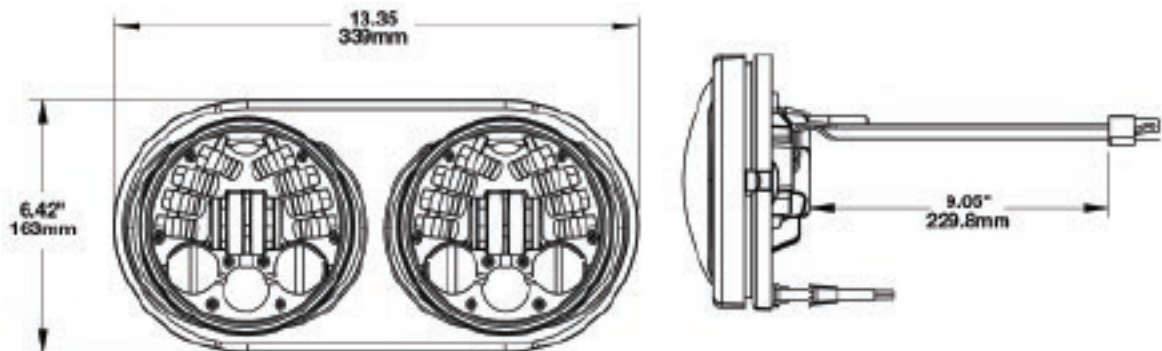
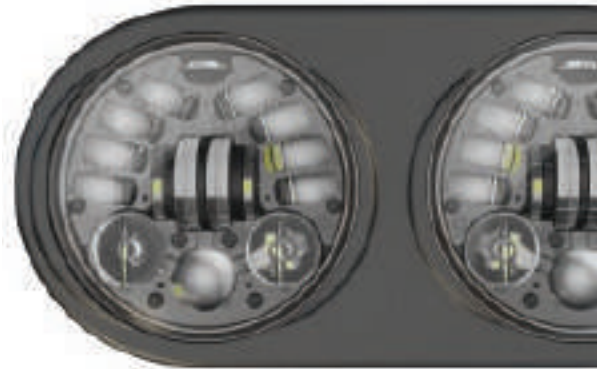

**ADAPTIVE**

PART #	BEZEL	DESCRIPTION
0555131	Black	DOT/ECE/High/Low
0555141	Chrome	DOT/ECE/High/Low

**NON-ADAPTIVE**

PART #	BEZEL	DESCRIPTION
0553951	Black	DOT/ECE/High/Low
0553961	Chrome	DOT/ECE/High/Low

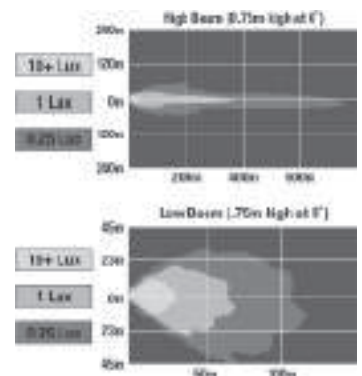

If your bike is operated in the United States you do NOT need to connect the Front Position wire (red) unless your bike is equipped with a front position light.



## PRODUCT SPECIFICATIONS

**Raw Lumen Output:**  
3,520 (High Beam); 2,120 (Low Beam)

**Effective Lumen Output:**  
1,600 (High Beam); 1,050 (Low Beam)

**Candela Output:**  
60,000 (High Beam); 8,300 (Low Beam)

**Connector/Wiring:**  
Integral Connectors

**Operating Voltage:**  
9-16V DC

**Current Draw:**  
Low Beam: 1.9A @ 12V DC  
High Beam: 3.2A @ 12V DC  
Low Beam at Full Lean: 4.5A @ 12V DC  
High Beam at Full Lean: 5.5A @ 12V DC

**Retrofit Information:**  
Designed to fit Victory® motorcycles with diamond shaped headlights

**Standards:**

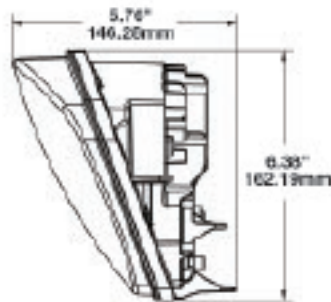
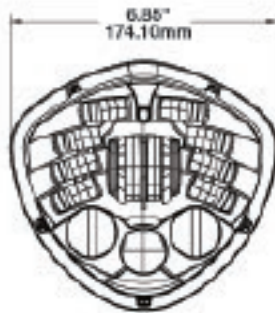

PART #	BEZEL	DESCRIPTION
0555151	Black	DOT/ECE/High/Low
0555161	Chrome	DOT/ECE/High/Low

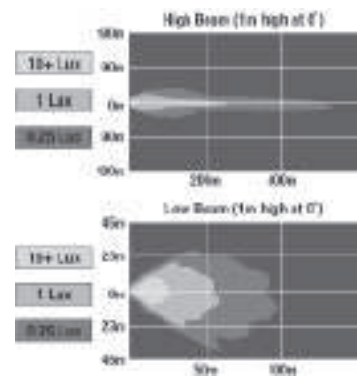



# 8700 EVO 2 DUAL BURN

## PRODUCT SPECIFICATIONS

### Raw Lumen Output:

3,200 (High Beam); 1,770 (Low Beam)

### Effective Lumen Output:

1,260 (High Beam); 750 (Low Beam)

### Candela Output:

71,500 (High Beam); 35,003 (Low Beam)

### Connector/Wiring:

H4

### Operating Voltage:

9-32V DC

### Current Draw:

High Beam: 3.50A @ 12V; 1.80A @ 24V DC

Low Beam: 2.00A @ 12V; 1.10A @ 24V DC

### Retrofit Information:

7" Round (PAR56)

### Standards:

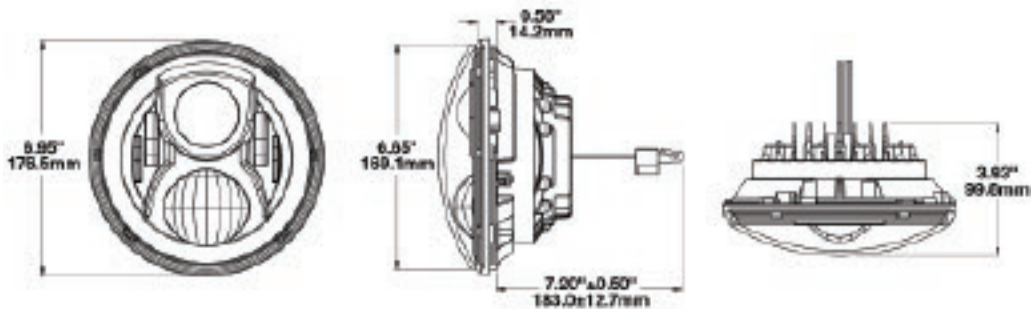

PART #	BEZEL	DESCRIPTION
0554941	Black	DOT/High/Low
0554961	Chrome	DOT/High/Low
0554981	Black	DOT/High/Low with #3156351
0554991	Chrome	DOT/High/Low with #3156351

PART #	ACCESSORIES
3156351	Mounting Ring Kit for 7" Round (PAR56) Headlights
8200411	H4 Wire Harness Kit 2014 & Newer Harley Bikes

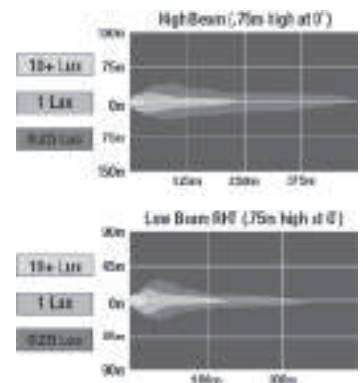



# 8700 EVO 2 PRO

## PRODUCT SPECIFICATIONS

### Raw Lumen Output:

4,170 (High Beam); 2,340 (Low Beam)

### Effective Lumen Output:

1,340 (High Beam); 694 (Low Beam)

### Candela Output:

84,700 (High Beam); 30,600 (Low Beam)

### Connector/Wiring:

H4

### Operating Voltage:

9-32V DC

### Current Draw:

High Beam: 3.60A @ 12V; 1.80A @ 24V DC  
 Low Beam: 2.00A @ 12V; 1.10A @ 24V DC  
 Front Position: 0.16A @ 12V; 0.10A @ 24V DC  
 DRL: 1.60A @ 12V; 0.80A @ 24V DC

### Retrofit Information:

7" Round (PAR56)

### Standards:

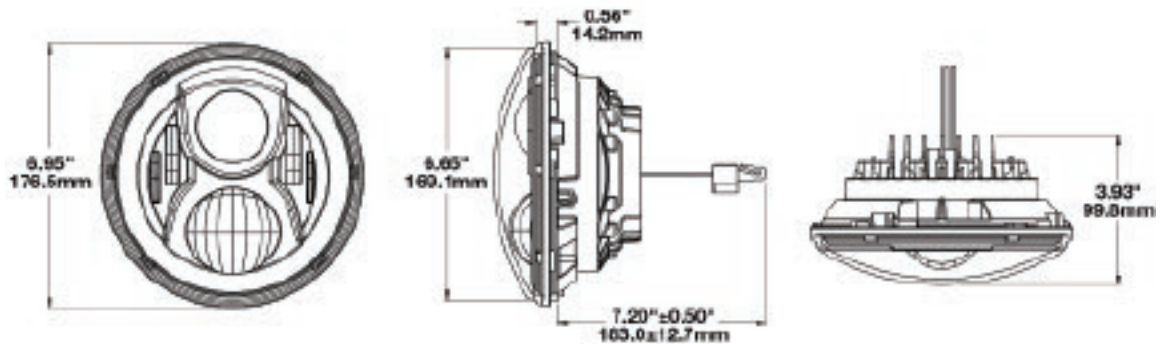

### PART # BEZEL DESCRIPTION

0556961	Black	ECE/LHT/High/Low/FP/DRL
0556951	Chrome	ECE/LHT/High/Low/FP/DRL
0556981	Black	ECE/RHT/High/Low/FP/DRL
0556971	Chrome	ECE/RHT/High/Low/FP/DRL

### PART # ACCESSORIES

3156351	Mounting Ring Kit for 7" Round (PAR56) Headlights
8200411	H4 Wire Harness Kit 2014 & Newer Harley Bikes

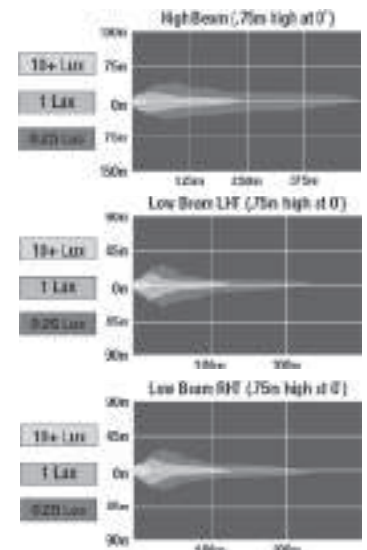

# MODEL 8720



## PRODUCT SPECIFICATIONS

### Raw Lumen Output:

1,620 (High Beam); 925 (Low Beam)

### Effective Lumen Output:

850 (High Beam); 500 (Low Beam)

### Candela Output:

41,000 (High Beam); 12,110 (Low Beam)

### Connector/Wiring:

H4

### Operating Voltage:

9-16V DC

### Current Draw:

Front Position: 2.67A @ 12V DC

Low Beam: 1.67A @ 12V DC

Front Position: 0.13A @ 12V DC

### Retrofit Information:

7" Round (PAR56)

### Standards:

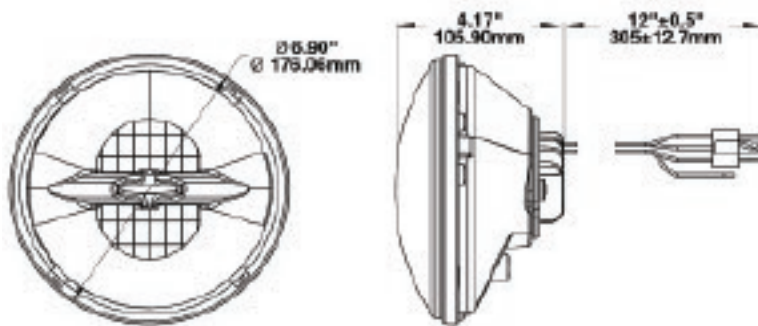

PART #	BEZEL	DESCRIPTION
0552861	Chrome	DOT/ECE/High/Low

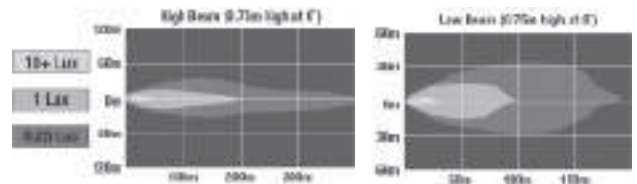

If your bike is operated in the United States you do NOT need to connect the Front Position wire (red) unless your bike is equipped with a front position light.



## PRODUCT SPECIFICATIONS

**Raw Lumen Output:**

2,250 (High Beam), 2,025 (Low Beam)

**Effective Lumen Output:**

1,150 (High Beam), 850 (Low Beam)

**Candela Output:**

48,000 (High Beam), 1,150 (Low Beam)

**Connector/Wiring:**

H4

**Operating Voltage:**

9-16V DC

**Current Draw:**

High Beam: 2.9A @ 13.5V DC

Low Beam: 1.9A @ 13.5V DC

Front Position: 0.092A @ 13.5V DC

Low Beam at Full Lean: 3.5A @ 13.5V DC

High Beam at Full Lean: 4.5A @ 13.5V DC

**Retrofit Information:**

7" Round (PAR56)

**Standards:**

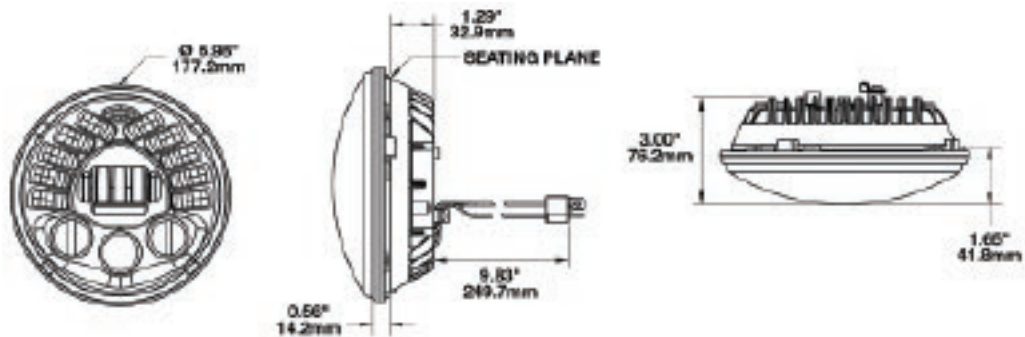

**ADAPTIVE**

PART #	BEZEL	DESCRIPTION
0555011	Black	DOT/ECE/High/Low
0555031	Chrome	DOT/ECE/High/Low
0555051	Black	DOT/ECE/High/Low with #3156351
0555061	Chrome	DOT/ECE/High/Low with #3156351

**NON-ADAPTIVE**

PART #	BEZEL	DESCRIPTION
0553421	Black	DOT/ECE/High/Low
0553431	Chrome	DOT/ECE/High/Low

**PART # ACCESSORIES**

8200411	Wire Harness H4 for 7" Round (PAR56) Headlights (2014 & newer Harley bikes)
3156351	Mounting Ring Kit for 7" Round (PAR56) Headlights

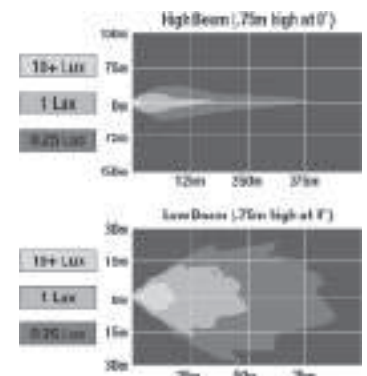

If your bike is operated in the United States you do NOT need to connect the Front Position wire (red) unless your bike is equipped with a front position light.



## PRODUCT SPECIFICATIONS

### Raw Lumen Output:

2,250 (High Beam); 2,025 (Low Beam)

### Effective Lumen Output:

1,150 (High Beam); 850 (Low Beam)

### Candela Output:

48,000 (High Beam); 11,500 (Low Beam)

### Connector/Wiring:

Bare Leads

### Operating Voltage:

9-16V DC

### Current Draw:

High Beam: 2.9A @ 13.5V DC

Low Beam: 1.9A @ 13.5V DC

Front Position: 0.092A @ 13.5V DC

Low Beam at Full Lean: 3.5A @ 13.5V DC

High Beam at Full Lean: 4.5A @ 13.5V DC

### Retrofit Information:

7" Round (PAR56) Pedestal

### Standards:

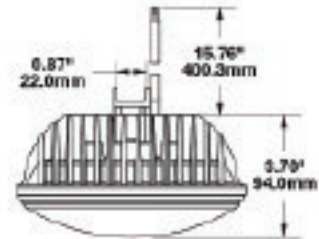
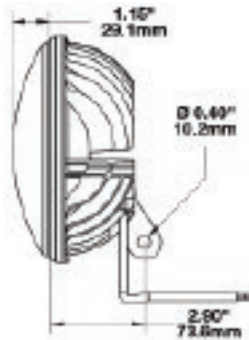

### ADAPTIVE

PART #	BEZEL	DESCRIPTION
0555071	Black	DOT/ECE/High/Low
0555081	Chrome	DOT/ECE/High/Low

### NON-ADAPTIVE

PART #	BEZEL	DESCRIPTION
0553441	Black	DOT/ECE/High/Low
0553451	Chrome	DOT/ECE/High/Low

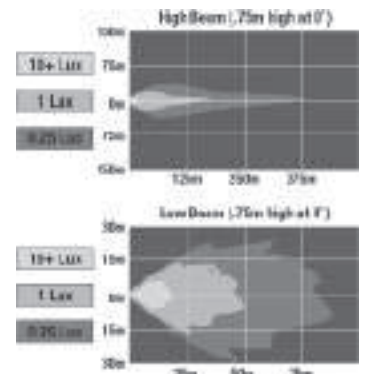

If your bike is operated in the United States you do NOT need to connect the Front Position wire (red) unless your bike is equipped with a front position light.



# MODEL 93



## PRODUCT SPECIFICATIONS

### Raw Lumen Output:

630 (High Beam); 1,910 (Low Beam)

### Effective Lumen Output:

230 (High Beam); 575 (Low Beam)

### Candela Output:

45,000 (High Beam); 18,500 (Low Beam)

### Connector/Wiring:

High Beam: Deutsch DT04-3P

Low Beam: Deutsch DT04-2P

### Operating Voltage:

10-31V DC

### Current Draw:

Low Beam: 1.97A @ 12V; 0.98A @ 24V DC

High Beam: 0.80A @ 12V; 0.40A @ 24V DC

Front Position: 0.40 @ 12V; 0.20 @ 24V DC

### Retrofit Information:

Standard 90mm lamps

### Standards:

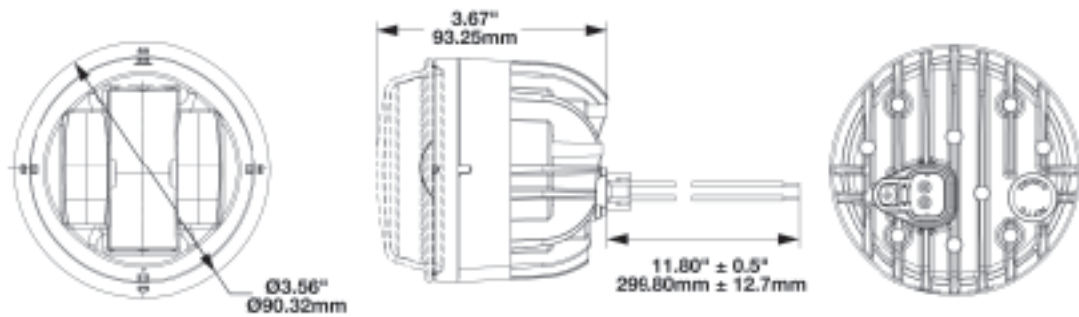

### PART # DESCRIPTION

0553081	SAE/ECE/Reg113/Low
0553091	ECE/LHT/Reg112/Low
0553101	DOT/ECE/RHT/Reg112/Low
0553071	DOT/ECE/High
0554381	SAE/ECE/High with FP
0556701	SAE/ECE/Fog Lamp
0347941	SAE/ECE/DRL/Turn Signal

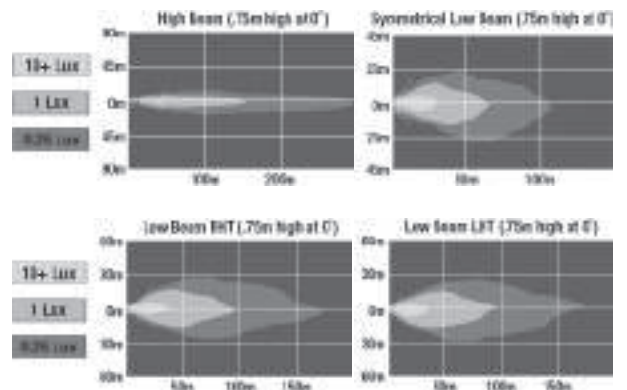

### PART # ACCESSORIES

8001601	Single Lamp Pedestal Mount Bracket
8001461	1.5mm 3-Point Mount
8001471	3.0mm 3-Point Mount





## PRODUCT SPECIFICATIONS

### Raw Lumen Output:

1,800 (High Beam); 1,600 (Low Beam)

### Effective Lumen Output:

497 (High Beam); 321 (Low Beam)

### Candela Output:

41,800 (High Beam); 14,600 (Low Beam)

### Connector/Wiring:

Deutsch DT04-4P

### Operating Voltage:

10-32V DC

### Current Draw:

High Beam: 1.8A @ 12V; 1.0A @ 24V DC

Low Beam: 1.5A @ 12V; 0.8A @ 24V DC

Front Position: 0.1A @ 12V; 0.06A @ 24V DC

### Retrofit Information:

100mm Bi-LED Headlamp

### Standards:

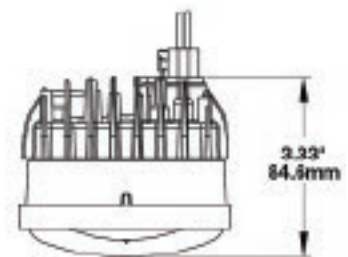
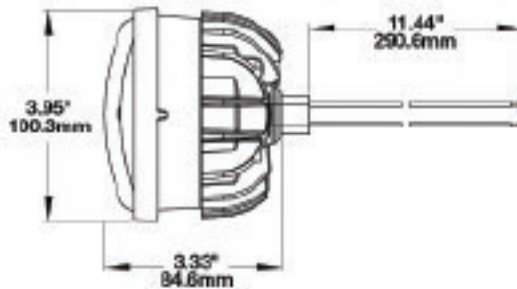

### PART # DESCRIPTION

0554831 DOT/ECE/RHT/High/Low/Reg 112

0554911 ECE/LHT/High/Low/Reg 112

0554921 DOT/ECE/High/Low/Reg 113

### PART # MOUNTING OPTIONS

8001511 3-Point Mount for 3mm Mounting Frame

8001521 Single Lamp Pedestal Mount Bracket

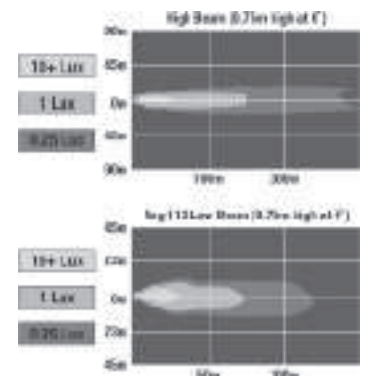

# MODEL 515



## PRODUCT SPECIFICATIONS

**Raw Lumen Output:**

540 Lumens (Low Beam)

**Effective Lumen Output:**

420 Lumens (Low Beam)

**Connector/Wiring:**

Integrated 4-Pin Deutsch Weather-Proof Socket (DT04-4P)

**Operating Voltage:**

9-60V DC

**Current Draw:**

Low Beam: 0.60A @ 12V; 0.30A @ 24V; 0.20A @ 36V; 0.15A @ 48V DC  
 Front Position: 0.05A @ 12V; 0.05A @ 24V; 0.05A @ 36V; 0.05A @ 48V DC  
 Turn Signal: 1.45A @ 12V; 0.70A @ 24V; 0.45A @ 36V; 0.40A @ 48V DC

**Retrofit Information:**

4" x 8" material handling headlight

**Standards:**

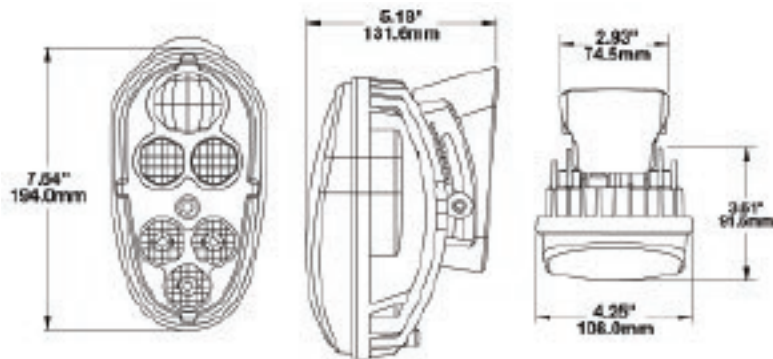

PART #	BEZEL	DESCRIPTION
0548901	Black	Material Handling Headlight
0549201	Chrome	Material Handling Headlight

PART #	ACCESSORIES
8200311	515 Base Mount Service Kit

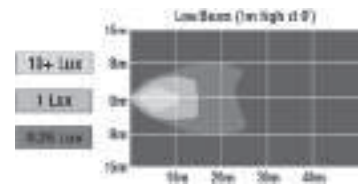

## PRODUCT SPECIFICATIONS

**Raw Lumen Output:**  
765

**Effective Lumen Output:**  
380

**Connector/Wiring:**  
11" Bare Leads

**Operating Voltage:**  
10-32V DC

**Current Draw:**  
0.340A @ 24V DC

**Retrofit Information:**  
2" x 6" material handling headlight

**Standards:**

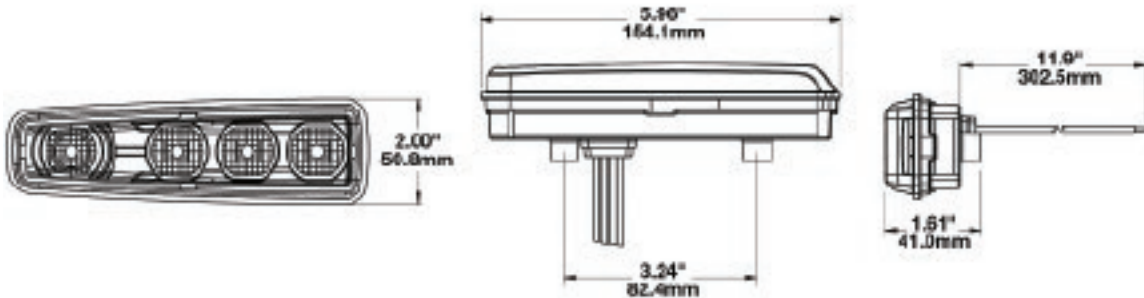

PART #	DESCRIPTION
0549481	Low /Turn Signal/Front Position

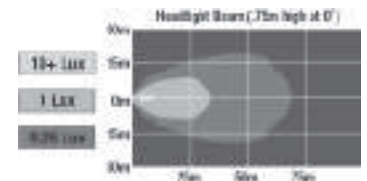

# MODEL 710



## PRODUCT SPECIFICATIONS

**Raw Lumen Output:**

2,000 (6 LEDs); 1,630 (3 LEDs)

**Effective Lumen Output:**

1,600 (6 LEDs); 780 (3 LEDs)

**Connector/Wiring:**

Integrated 3-Pin Packard (12129615)

**Operating Voltage:**

9-110V DC

**Current Draw:**

3 LEDs: 1.54A @ 12V; 0.67A @ 24V; 0.33A @ 60V; 0.20A @ 110V DC

6 LEDs: 1.59A @ 12V; 0.74A @ 24V; 0.34A @ 60V; 0.23A @ 110V DC

**Retrofit Information:**

Compact work light, ideal for material handling equipment like forklifts

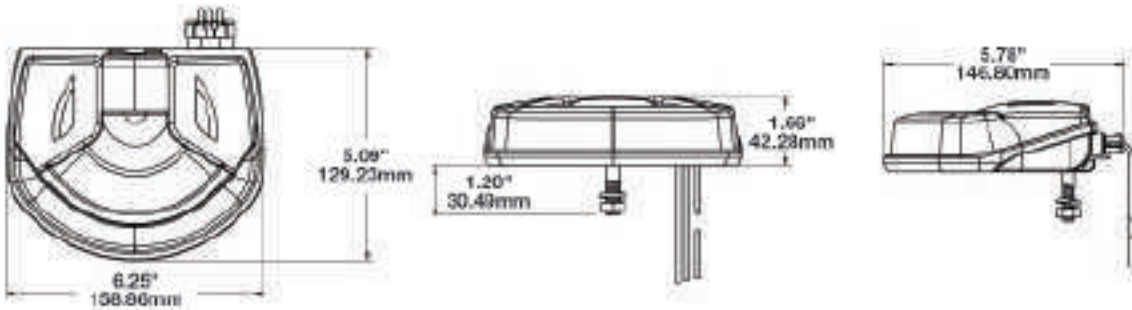

**PART # DESCRIPTION**

1000101 Vertical Flood Beam

**PART # ACCESSORIES**

8200501 Click Bond Stud Mounting Kit

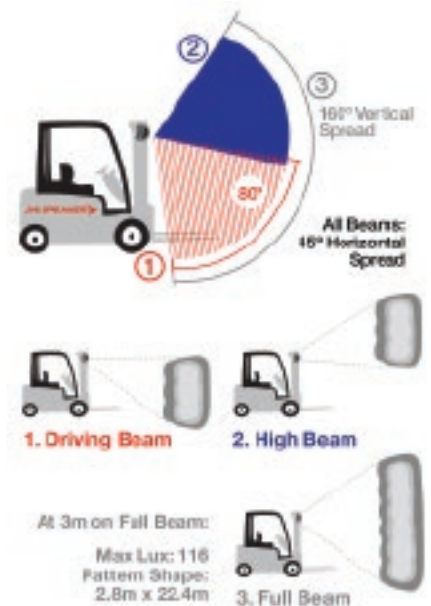

# MODEL 791

## PRODUCT SPECIFICATIONS

### Raw Lumen Output:

1,820 (Driving/Flood); 800 (Fog)

### Effective Lumen Output:

1,200 (Driving/Flood); 250 (Fog)

### Candela Output:

6,700 (Fog)

### Connector/Wiring:

Driving/Flood: Deutsch DT04-2P

Fog: Integrated 2-Pin Deutsch Connector

### Operating Voltage:

Driving/Flood: 9-32V DC

Fog: 10-18V DC

### Current Draw:

Driving/Flood: 1.27A @ 12V; 0.78A @ 24V DC

Fog: 0.55A @ 10V; 0.88A @ 12V; 1.10A @ 18V DC

### Retrofit Information:

6" x 2" Rectangle

### Standards:



FOG



DRIVING



FLOOD

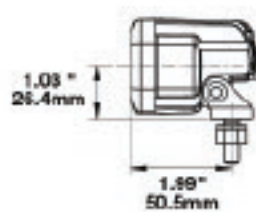
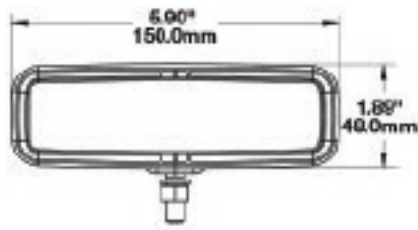

### PART # DESCRIPTION

1603601	SAE/ECE/Fog
1603603	SAE/ECE/Fog/Kit of 2
1603511	Driving
1603521	Driving Light with Flood

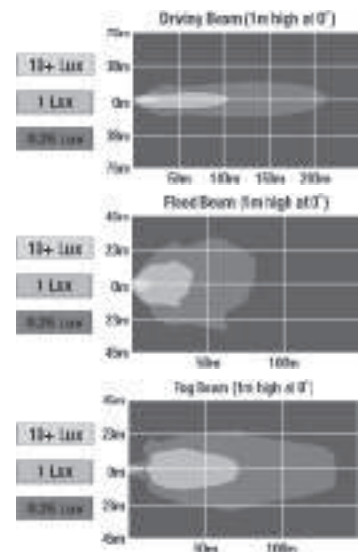

# MODEL 6048

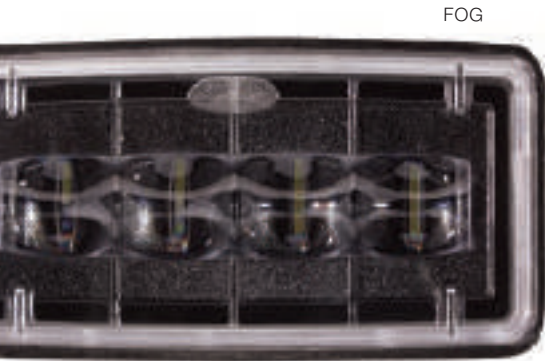

FOG

DRIVING



## PRODUCT SPECIFICATIONS

### Raw Lumen Output:

1,280 (Spot/Driving Beam); 800 (Fog Beam)

### Effective Lumen Output:

520 (Spot Beam); 430 (Driving Beam); 250 (Fog Beam)

### Candela Output:

8,600 (Spot Beam); 3,000 (Driving Beam)

### Connector/Wiring:

Bare Leads

### Operating Voltage:

Driving Beam & Spot Beam: 9-32V DC

Fog Beam: 9-18V DC

### Current Draw:

1.2A @ 12V; 0.6A @ 24V DC

### Retrofit Information:

2" x 5" Rectangle

### Standards:

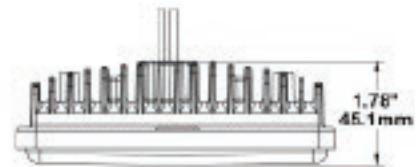
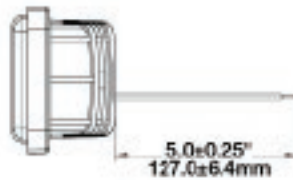
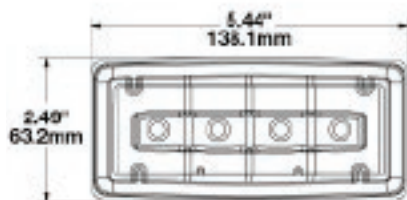

PART #	DESCRIPTION
0543591	Driving
0548631	Spot
0549691	SAE/ECE/Fog

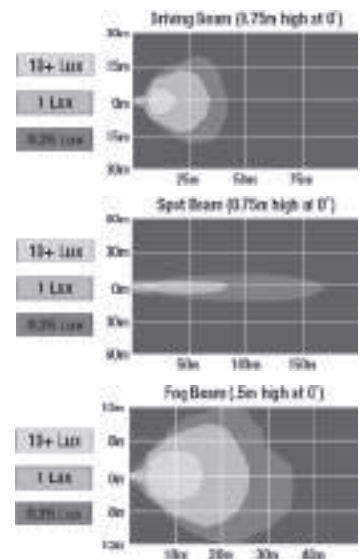

# 6130 EVOLUTION

## PRODUCT SPECIFICATIONS

### Raw Lumen Output:

2,230 (High Beam); 1,330 (Low Beam)  
1,760 (High Beam Only); 1,690 (Low Beam Only)

### Effective Lumen Output:

840 (High Beam); 440 (Low Beam)  
955 (High Beam Only); 640 (Low Beam Only)

### Connector/Wiring:

12" Bare Wires

### Operating Voltage:

10-30V DC

### Current Draw:

High Beam: 3.00A @ 12V; 1.43A @ 24V DC  
Low Beam: 2.30A @ 12V; 1.01A @ 24V DC  
Front Position: 0.12A @ 12V; 0.09A @ 24V DC  
DRL: 0.44A @ 12V; 0.24A @ 24V DC  
High Beam Only: 1.84A @ 12V; 0.84A @ 24V DC  
Low Beam Only: 2.07A @ 12V; 0.96A @ 24V DC

### Retrofit Information:

4.75" Round

### Standards:

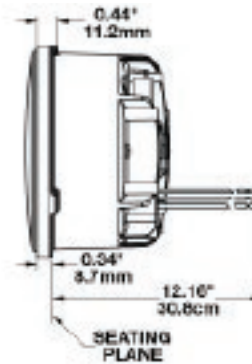
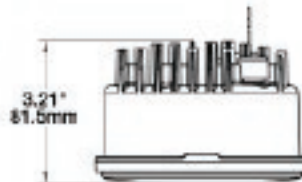
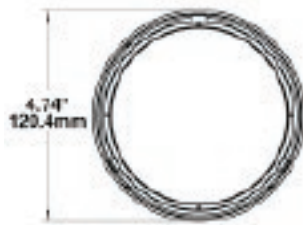

PART #	DESCRIPTION
0549871	DOT/ECE/High/FP
0549851	DOT/ECE/RHT/Low/DRL
0549881	DOT/ECE/RHT/High/Low/FP
0549891	ECE/LHT/High/Low/FP
0549861	ECE/LHT/Low/DRL

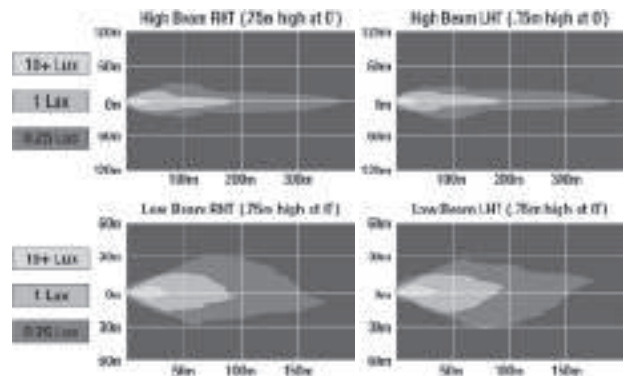

If your vehicle is operated in the United States you do NOT need to connect the Front Position wire (red) unless your vehicle is equipped with a front position light.

# 8415 EVOLUTION



## PRODUCT SPECIFICATIONS

**Raw Lumen Output:**  
1,075 (High Beam); 430 (Low Beam)

**Effective Lumen Output:**  
720 (High Beam); 240 (Low Beam)

**Connector/Wiring:**  
PE 12110293

**Operating Voltage:**  
10-30V DC

**Current Draw:**  
High Beam: 1.14A @ 12V; 0.57A @ 24V DC  
Low Beam: 0.41A @ 12V; 0.22A @ 24V DC

**Retrofit Information:**  
4.5" Round (PAR36)

**Standards:**



ADJUSTABLE MOUNT

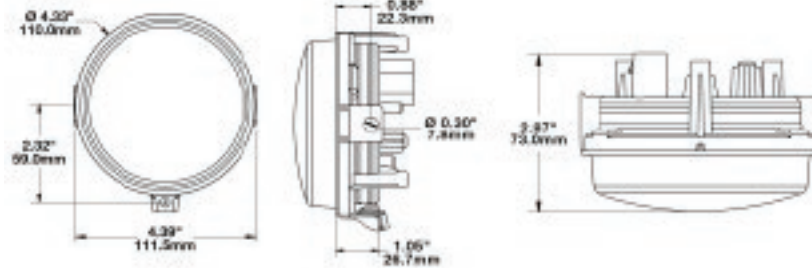

FIXED MOUNT

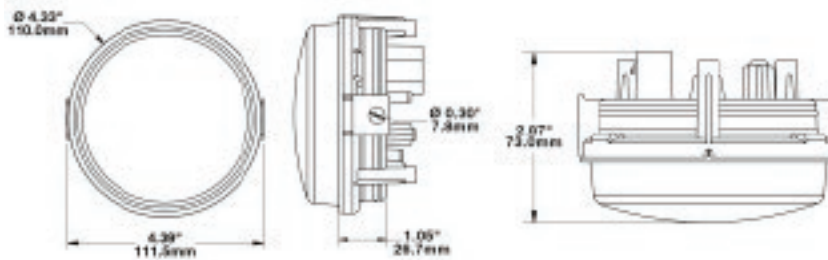

PART #	DESCRIPTION
0551191	SAE/ECE/High/Low/Adjustable Mount
0552031	SAE/ECE/High/Low/Adjustable Mount - UL Version
0551761	SAE/ECE/High/Low/Fixed Panel Mount

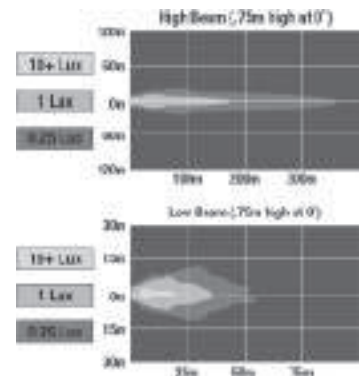



## PRODUCT SPECIFICATIONS

**Raw Lumen Output:**  
2,200

**Effective Lumen Output:**  
1,800 (Heated); 2,041 (Non-Heated)

**Candela Output:**  
230,000 (Heated); 260,000 (Non-Heated)

**Connector/Wiring:**  
Standard Sealed Beam Style Screw Terminal

**Operating Voltage:**  
18-130V DC

**Current Draw:**  
Heated/Heater On:  
High Output: 3.20A @ 24V; 1.20A @ 75V; 0.85A @ 110V DC  
Low Output: 2.60A @ 24V; 0.85A @ 75V; 0.75A @ 110V DC  
Non-Heated/Heater Off:  
High Output: 2.10A @ 24V; 0.75A @ 75V; 0.55A @ 110V DC  
Low Output: 1.00A @ 24V; 0.45A @ 75V; 0.30A @ 110V DC

**Retrofit Information:**  
7" Round Locomotive Headlight

**Standards:**



HEATED

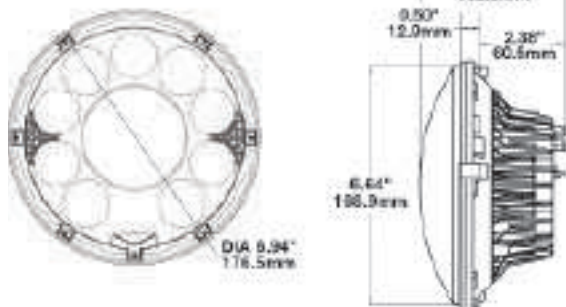

NON-HEATED

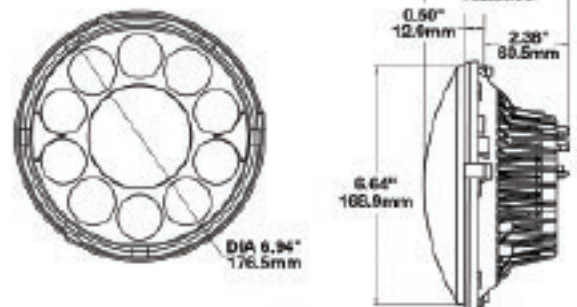

HEATED

PART #	DESCRIPTION
0551901	Locomotive Headlight with Spot

NON-HEATED

PART #	DESCRIPTION
0554601	Locomotive Headlight with Spot

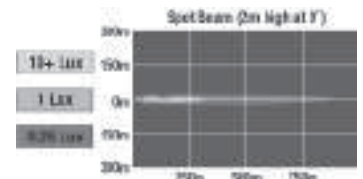

# INDEX

---

EVO J3	8 - 9
Model 93	22, 64
Model 93 M	46
Model 95	23
Model 97	24, 47, 65
Model 515	66
Model 516	67
Model 710	68
Model 791	25, 69
Model 6025	48
Model 6045	26, 49
Model 6048	27, 70
Model 6130 Evolution	50, 71
Model 6145 J2	10
Model 6146	11
Model 8415 Evolution	51, 72
Model 8620	52
Model 8630 & 8631 Evolution	28
Model 8632 Evolution	29
Model 8690 & 8690 Adaptive 2	53
Model 8691 & 8691 Adaptive 2	54
Model 8692 & 8692 Adaptive 2	55
Model 8695 Adaptive 2	56
Model 8700 Evolution 2 Dual Burn	12, 30, 57
Model 8700 Evo 2 Pro	13, 31, 59
Model 8700 Evo J Classic	14

---

Model 8700 Evolution J2	16
Model 8700 Evolution 2R	15
Model 8710	33
Model 8720	60
Model 8770 Gen 3	73
Model 8790 & 8790 Adaptive 2	61
Model 8791 & 8791 Adaptive 2	62
Model 8800 Evolution 2	17, 34
Model 8801 Evolution	35
Model 8900 Evolution 2	18, 36
Model 8910 Evolution 2	19, 37
Model 9800	38
Model 9800 HS (High Speed)	39
Model 9900 LP (Low Profile)	40

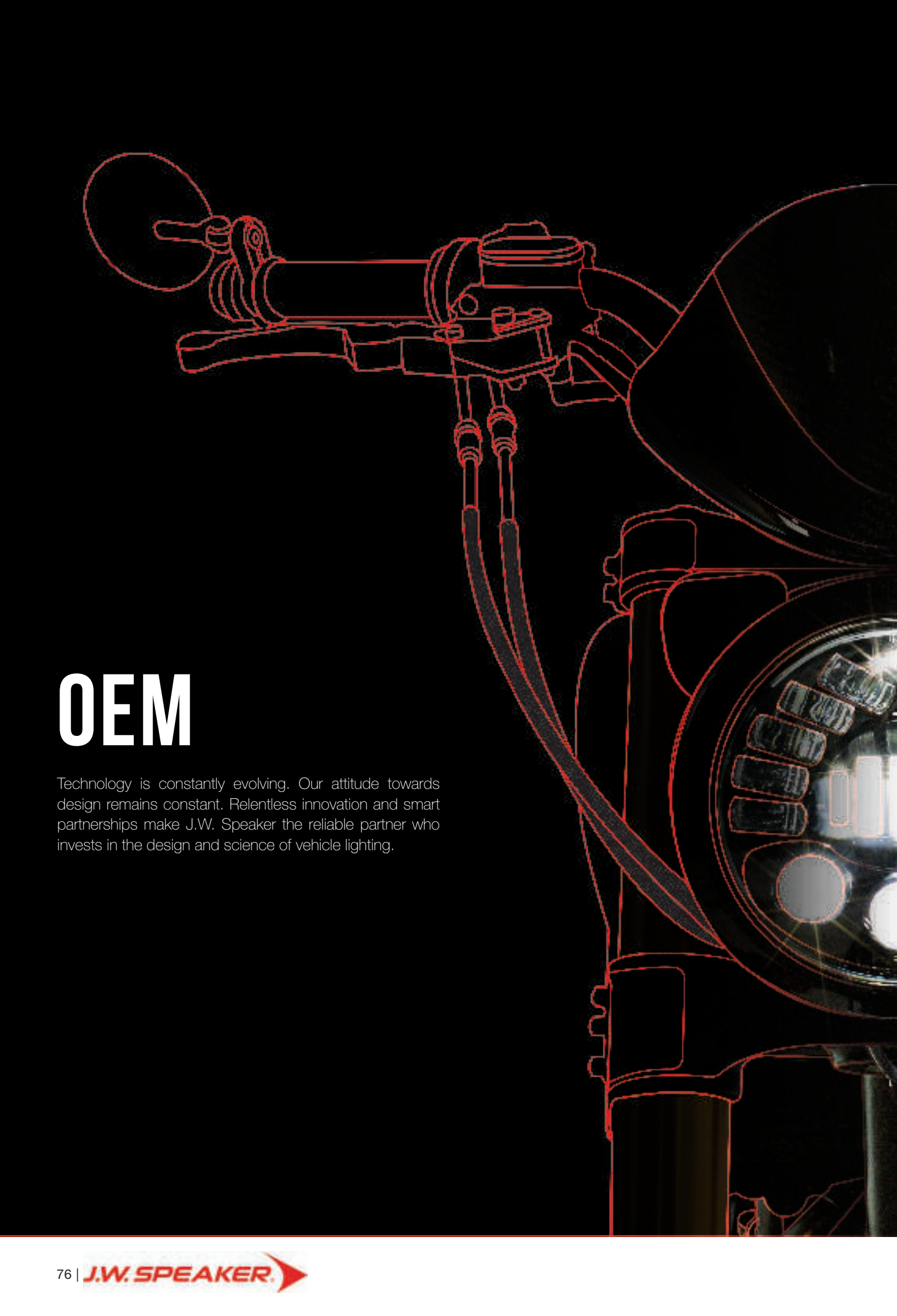

# OEM

Technology is constantly evolving. Our attitude towards design remains constant. Relentless innovation and smart partnerships make J.W. Speaker the reliable partner who invests in the design and science of vehicle lighting.



# AFTERMARKET

Look good or drive safely. That's often your choice with Aftermarket lights, but J.W. Speaker does not compromise. Our engineers and designers don't cut corners. The result is power and beauty that makes you feel good about the look of your vehicle — and your safety.

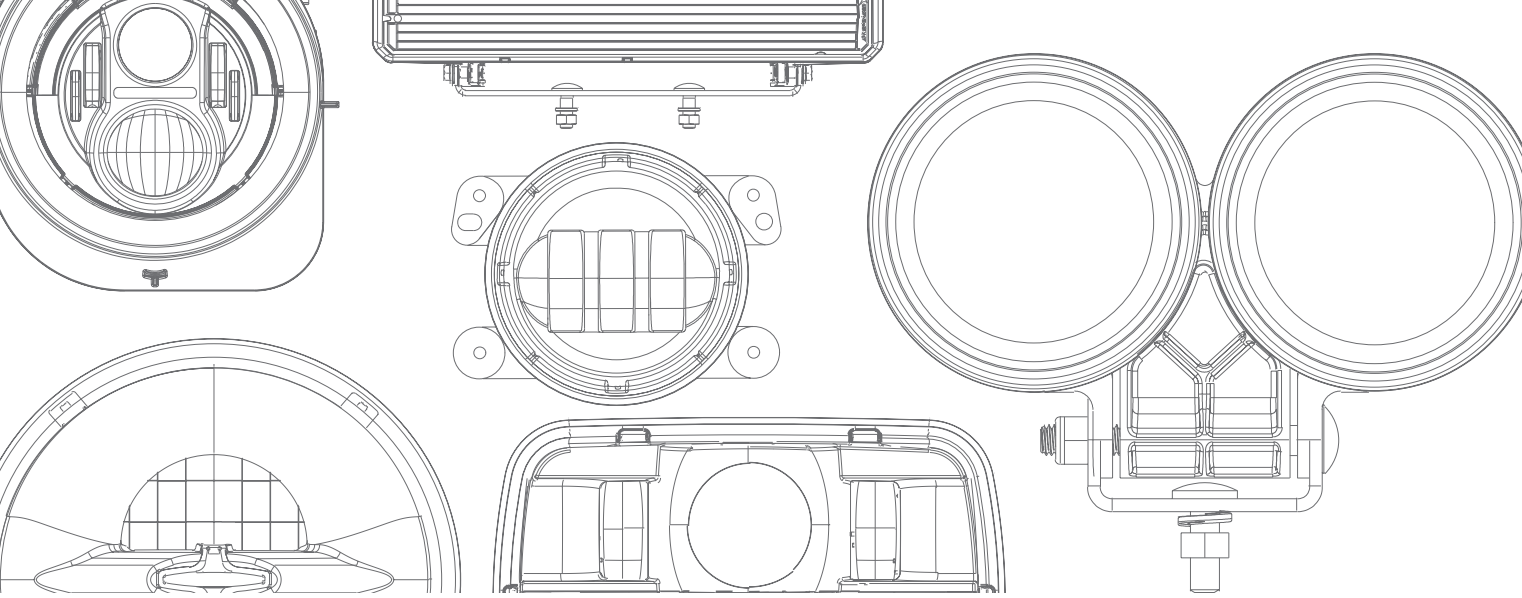

**J.W. SPEAKER®**  
*Engineered. Lighting. Solutions.*

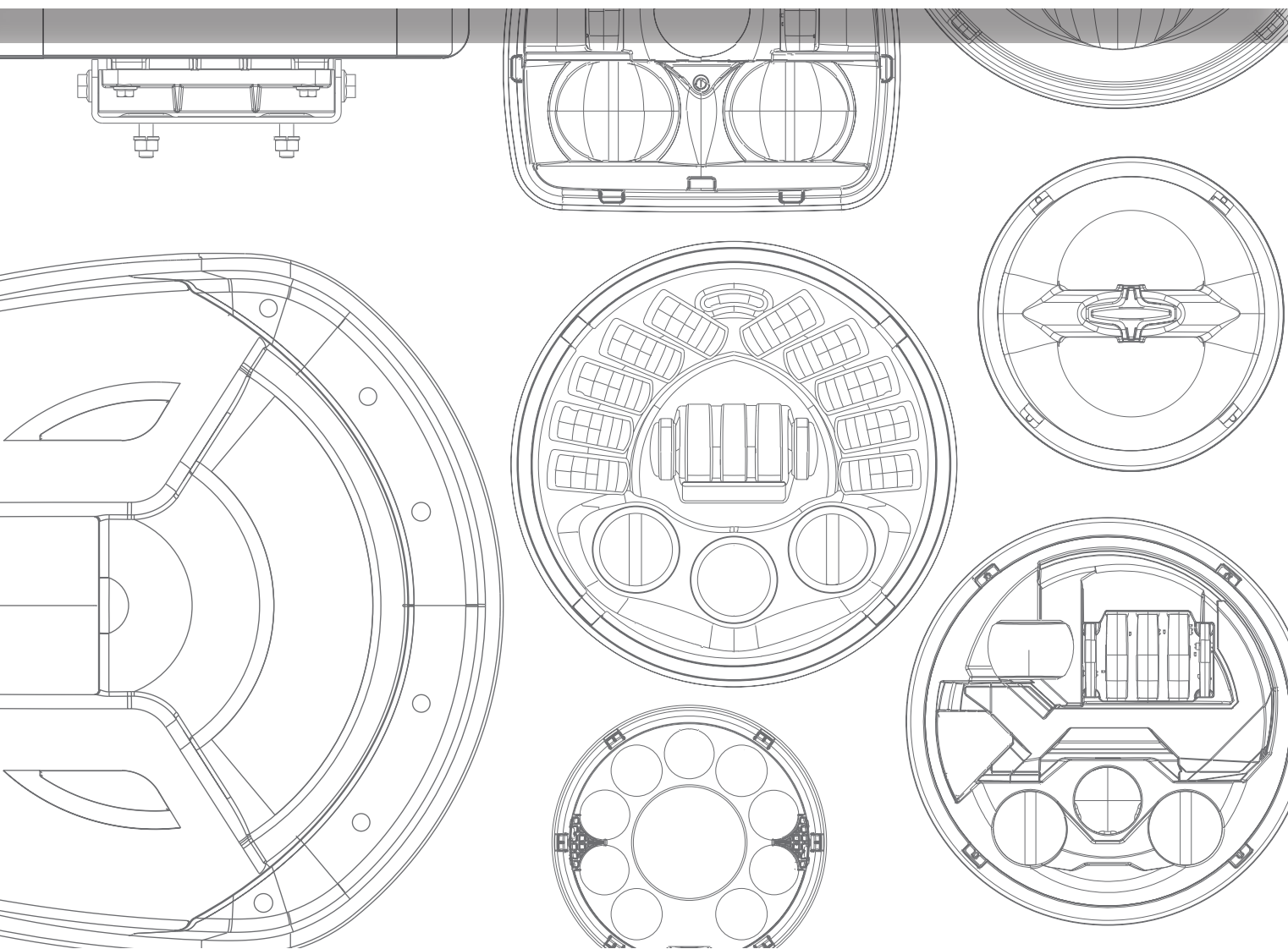

Learn more about custom and factory fog lights we have.