





## ***ALWAYS MOVING FORWARD... FUTURE HOME OF LOKAR***

Yet another year has passed; where does the time go? Lokar has been very busy this past year getting situated for expansion and more great products.

With 2014 marking our 26th year, what better time than now to enlarge our facilities and our product line for the next quarter century and beyond? We are excited about our new corporate headquarters and manufacturing facility located in the Westbridge Business Park only a few miles from our current location. As always, our products will be manufactured in the USA.

Lokar has spent the last year planning and designing our new facility with state of the art equipment and efficiencies to improve our processes. Increased space allows us to concentrate on ***Innovation, Quality and Growth***.

- With ***Innovation*** we are prepared to develop cutting edge products, meeting the demands of modern day drivetrain technology, such as our new Drive-By-Wire Pedal introduced at SEMA.
- Our concentration on ***Quality*** remains one of the highest priorities we have. With the new facility, we will be in a position to implement new and improved quality practices, giving you the ultimate experience in quality products.
- With our new found space, ***Growth*** will be welcomed and we will be in a position for many years to accommodate the new business that comes from those innovative, cutting edge products.

We have brought in new, talented staff with experience from different markets who have innovative ideas and the ability to meet our needs of high quality products that our customers have always come to appreciate.

Our priorities are clear – run our business with Honesty and Integrity and provide our customers with USA quality manufactured products along with unsurpassed service after the sale and dedication to our customers.



We look forward to another 25 years creating exciting products for our customers to help bring their own visions to fruition.

Thank you to all of our customers for your everlasting loyalty. We appreciate every one of you! Lokar wishes all of our customers a very rewarding and peaceful 2014.

  
*Skip and Debbie Walls*

# CONTENTS

## Shifters

Automatic Transmission Shifters.....	2
Nostalgia Automatic Transmission Shifters.....	3
"Radical 32" Automatic Transmission Shifters.....	3
16" Bench Bend Automatic Transmission Shifters.....	3
Floor Mount Automatic Transmission Shifters.....	4
Cable Operated Automatic Transmission Shifters.....	5
Tailmount Automatic Transmission Shifters.....	6
Bell Crank Kits.....	6
Knob & Lever Length Designations.....	7
Transmission Identification.....	7
Lokar Aluminum Shifter Knobs.....	8
 Premium Lokar Aluminum Shifter Knobs.....	8
 Lokar Shifter Knob Adapter.....	9
 Knobs for Lokar Shifter Knob Adapter.....	9
Manual Transmission Shifter Knobs.....	10
Chevrolet/GMC 5-10 5-Speed Manual Shift Lever Adapter.....	10
Billet Aluminum Tremec/Borg Warner Shifter Levers.....	11
Manual Transmission Shifter Levers.....	11

## Automatic Transmission Accessory Parts

Ford AOD Selector Shaft and Arm.....	12
Billet Aluminum Adjustable Trans Shift Arm.....	12
Back-Up Light or Neutral Safety Switch Kit.....	12

## Shift Indicators

Cable Operated LED Shift Indicator Kits.....	13
Sensor and Remote Kits.....	13
Billet Aluminum LED Dash Indicator with Sensor Kit.....	14-15
Billet Aluminum LED Dash Bezels Only.....	14-15
Billet Aluminum LED Boot Indicator with Sensor Kit.....	14-15
Billet Aluminum LED Boot Indicator with Boot.....	14-15

## Shifter Boots and Hand Brake Boots

Hi-Top and Deluxe Top Shifter Boots and Bezels.....	16
Shifter and Hand Brake Boot Sets.....	17

## Column Shift Linkage

Column Cable Shift Linkage.....	18
GM & Ford C4/C6 Adjustable Column Shift Linkage.....	19
Ford AOD/4R70W/AODE Adjustable Column Shift Linkage.....	19

## Interior Accessories

Oval Billet Aluminum Dash Insert 1932 Ford.....	20
Oval Billet Aluminum Dash Insert 6 Gauge.....	20
Oval Billet Aluminum Dash Insert 5 Gauge.....	20
Oval Billet Aluminum Interior Door Handles.....	21
Universal Door Latch Cable Release Kit.....	21
Billet Aluminum Door Handles, Window Cranks & Vent Window Cranks.....	22
Lakester™ Door Handles, Window Cranks & Vent Window Cranks.....	23
Billet Aluminum Door Pulls.....	24
Billet Aluminum Column Ware™.....	24
Combination Hood & Trunk Release Cable Kits.....	25
Trunk Release Cable Kits.....	25
Hood Release Cable Kits.....	25

## Emergency Brakes

Under-The-Dash Foot Operated Emergency Brake.....	26
Under-The-Dash Hand Operated Emergency Brake.....	27
Transmount Emergency Hand Brake.....	27
Floor Mount Emergency Hand Brake.....	28
Emergency Brake Warning Indicator Switch Kit.....	28



## Emergency Brake Cables & Connector Cables

Universal Emergency Brake Cables.....	29
Emergency Brake Application Chart.....	29
Transmount Emergency Brake Cables.....	30
Connector Cables for Under-The-Dash Foot Operated and Hand Operated Emergency Brakes.....	31
Rear Brake Clevis Kits.....	31
Connector Cables for Original Factory Under-The-Dash Hand Brakes.....	32
U-Cut-To-Fit Rear Brake Cable Kit for 1942 to 1954 Chevy Trucks.....	32



## Throttle Cables & Kickdowns

Hi-Tech Throttle Cables.....	33
Polished Hi-Tech Throttle Cables.....	34
Duo-Pak Kits.....	34
Hi-Tech Blower Drive Throttle Cables and Kickdowns.....	35
Hi-Tech Kickdown Kits.....	36
Polished Hi-Tech Kickdown Kits.....	36
Throttle Body and Carb End Fittings Chart.....	37
Lokar Kickdown End Fittings Chart.....	37
Hi-Tech TH400 Electric Kickdown Kit.....	38
TH350 Stainless Kickdown Bracket and Cable.....	38

## Mounting Brackets

Stainless Steel Carburetor Bracket and Return Springs.....	39
Tuned-Port Brackets.....	39
LT1 and LT4 Bracket Kits.....	39
LS1 Bracket.....	40
Ram Jet Brackets.....	40
 Throttle/Kickdown Cable Bracket for Edelbrock Pro Flo XT.....	40
EFI Bracket.....	41
 Tri-Power Bracket and Springs.....	41

## Mounting Brackets (continued)

 Throttle/Kickdown Cable Mounting Bracket for Stromberg Style Carburetors.....	41
Throttle Cable Mounting Bracket & Spring Return Kit for 4150 Series Carburetors.....	42
Billet Aluminum Throttle/Kickdown Bracket & Spacer Kit for Edelbrock Pro-Flo Fuel Injection.....	42
 Throttle/Kickdown Cable Mounting Bracket for Street Demon Carburetors.....	42
Billet Aluminum Throttle/Kickdown Cable Mounting Bracket for Edelbrock 4-Barrel Carburetors.....	43
Progressive Linkage System for In-line Dual Carburetors.....	43
Billet Aluminum Throttle/Kickdown Bracket Kit for Barry Grant Six Shooter.....	43

## Throttle Assemblies and Pedal Pads

 Drive-By-Wire Electronic Throttle Control Pedal Assembly.....	44
Competitor™ Series Throttle Assemblies.....	45
Lakester™ Throttle Assemblies & Pedal Pads.....	45
Eliminator Floor Mount Throttle Pedals.....	46
Billet Aluminum Adjustable Foot Rests.....	46
Standard Billet Aluminum Throttle Assemblies and Pedal Pads.....	47
XL Series Billet Aluminum Throttle Assemblies and Pedal Pads.....	48
Oval Billet Aluminum Throttle Assemblies and Pedal Pads.....	49
Steel Throttle Assemblies & Pedal Pads Standard & XL Series.....	50
Steel Spoon Throttle Assemblies and Pedal Pads.....	50

## Direct Fit Throttle Assemblies and Pedal Pads

1955 - 1957 Chevy Throttle Assemblies.....	51
1955 - 1957 Chevy Traditional Flat Brake Pads, Clutch Pads & Power Brake Pads.....	51
1955 - 1957 Curved Brake Pads, Clutch Pads & Power Brake Pads.....	52
1958 - 1965 Full Size Chevy Throttle Pedal Assemblies and Pedal Pads.....	52
1967 - 1969 Camaro/Firebird Throttle Assemblies.....	53
1967 - 1969 Camaro/Firebird Traditional Flat Brake/Clutch Pads.....	53
1967 - 1969 Camaro/Firebird Throttle Pads.....	53
1967 - 1969 Curved Camaro/Firebird Brake Pedal Pads.....	54
1964 - 1967 Chevelle Throttle Pedal Assemblies and Pedal Pads.....	54
1962 - 1972 Chevy II/Nova Throttle Pedal Assemblies and Pedal Pads.....	55
1958 - 1962 Corvette Brake/Clutch Pads.....	55
1997 & Later Corvette Throttle Pads.....	55
2005 - 2006 GTO Throttle Pads.....	55
1964 - 1970 Mustang Throttle Pedal Assemblies and Pedal Pads.....	56
Chevy/GMC C-10 Truck Throttle Pedal Assemblies and Curved Pads.....	57
Late Chevy Truck Throttle, Brake and Emergency Brake Pads.....	58
 Early Ford Bronco Throttle Pedal and Brake/Clutch Pad.....	59
Billet Aluminum Direct Fit Jeep Throttle Pedal Assemblies & Pedal Pads.....	59
1967 - 1969 Dart/Cuda Competitor™ Series Throttle Assemblies and Pedal Pads.....	60
Billet Aluminum Direct Fit Brake & Clutch Pedal Arms.....	61

## Transmission Dipsticks

Hi-Tech Flexible Braided Stainless Transmission Dipsticks.....	62-63
Anchor-Tight® Locking Flexible Transmission Dipsticks.....	64
Transmission Dipstick Application Chart.....	64

## Engine Dipsticks

Flexible Engine Dipsticks.....	65
 Big Block Flexible Engine Dipsticks.....	66
Billet Aluminum Engine Dipstick Small Block Chevy.....	66
Anchor-Tight® Locking Flexible Engine Dipsticks.....	67
Engine Dipstick Application Chart.....	67

## Exterior Products

"U-Cut-to-Fit" Speedometer Cable Kits.....	68
Billet Aluminum Oval LED Taillights.....	69
Adjustable-Level Self-Locking Hood and Trunk Prop.....	69
 Billet Exterior 12 Volt Door Handles.....	70
"U-Cut-to-Fit" Cruise Control Cables.....	71
Anchor-Tight® Headlight Braid.....	71

## Component Parts

Lokar Component Parts.....	72
Lever Conversion Kits.....	72

## Drag Racing Products

Interior Battery Disconnect Lever Kit.....	73
Anchor-Tight® Locking Flexible Engine Dipsticks.....	74
Engine Dipstick Application Chart.....	74
Anchor-Tight® Locking Flexible Transmission Dipsticks.....	75
Transmission Dipstick Application Chart.....	75
Lokar Dial-in Board, Cage Mount and Universal Adjustable Angle Mount Brackets.....	76
Billet Aluminum Safety LED Taillight.....	77
4500/4150 Series Carb Rod Type Throttle Linkage Spring Return Kit.....	77
4500/4150 Series Carb Push Pull Throttle Cable Mounting Bracket & Spring Return Kit.....	78

## Lokar Wear

 T-shirts, Sweatshirts, Umbrellas and Jackets.....	79-80
---	-------

 = New Products/Applications

# LOKAR AUTOMATIC

For more than two decades, automotive enthusiasts have experienced and enjoyed the superior craftsmanship, design and safety features of Lokar Automatic Transmission Shifters. When Lokar builds a shifter, whether it's for a street rod, truck, muscle car or off-road vehicle, safety is the first and foremost consideration.

The *Lokar Collection of Shifters* is designed to prevent accidental shifting from the Park position into Reverse, Drive, and Low gears with our Exclusive Safety Lock-Out Button. When adjusted properly, the Safety Lock-Out Button is flush with the knob and is virtually undetectable. Lokar also offers Shifter Knob Adapters for individuals who wish to personalize their shifter with a custom knob.

Lokar prides itself in the design and versatile mounting capabilities of their shifters. With Lokar's exclusive and innovative main plate and side brackets the shifters can be mounted in a number of positions front to rear, allowing the use of an existing floor opening or to create a unique location.

## Experience the Lokar Collection of Shifters for yourself!

*All Ford AOD Shifters require the use of a Lokar Kickdown Kit.*

(GM TH350 shown)



Choice of 4 factory installed knobs

- M** Original Brushed Billet Aluminum Mushroom
- B** Black Billet Aluminum Mushroom
- L** Hi-Tech Lokar Brushed Billet Aluminum
- LB** Black Hi-Tech Lokar Billet Aluminum

## Features

- Positive Lock-Out in Park and Neutral
- Neutral Safety Switch
- Operates with solid adjustable linkage
- Utilizes high quality rod ends
- 360 degree lever rotation for extra leg space
- Lever adjustments for dash and seat clearance
- Levers available in 32", 23", 16", 12", 10", 8" and 6" lengths\*
- Levers available in chrome-plated or black powder coat finish
- Choice of Original Mushroom, Black Anodized Mushroom, Hi-Tech Lokar or Black Anodized Lokar Knob factory installed with shifters\*
- Teflon®-lined shifter knob buttons for smooth operation
- Easy to remove shifter knobs for simple boot installation
- Gold iridited main plate and brackets
- All hardware included
- Accessory knobs available separately
- Available for GM, Ford and Chrysler Automatic Transmissions\*
- Shifter Boots sold separately

*\*Please specify transmission type, lever length and knob style when ordering*



Midnight Series™



Neutral Safety Switch



Exclusive Lock-Out Button

SHIFTERS

# TRANSMISSION SHIFTERS

## Nostalgia and "Radical 32" Automatic Transmission Shifters

Lokar Nostalgia Shifters are reminiscent of the early days of hot rodding. The classic double bend chromed lever and Black Mushroom knob gives you a "Blast to the Past" and is another exceptional example of Lokar's quality. This style of the Lokar Collection of Shifters is available in both 16" and 23" lever lengths and shares all of the same outstanding features of our single bend shifters including our Safety Lock-Out Button, neutral safety switch, main plate, and side brackets. Shifter boots sold separately. Available for GM, Ford and Chrysler Automatic Transmissions.

The "Radical 32" Automatic Transmission Shifter provides an amazing 3 feet of shifter at your fingertips! It satisfies the need for extreme, without sacrificing the exceptional features provided in all Lokar shifters. "Radical 32" is available in a classic double bend or our standard single bend chromed lever and is equipped with our Black Mushroom knob, or you can easily order one of our other standard or accessory knobs. Shifter boots sold separately. Available for GM, Ford and Chrysler Automatic Transmissions.

All Ford AOD Shifters require the use of a Lokar Kickdown Kit.

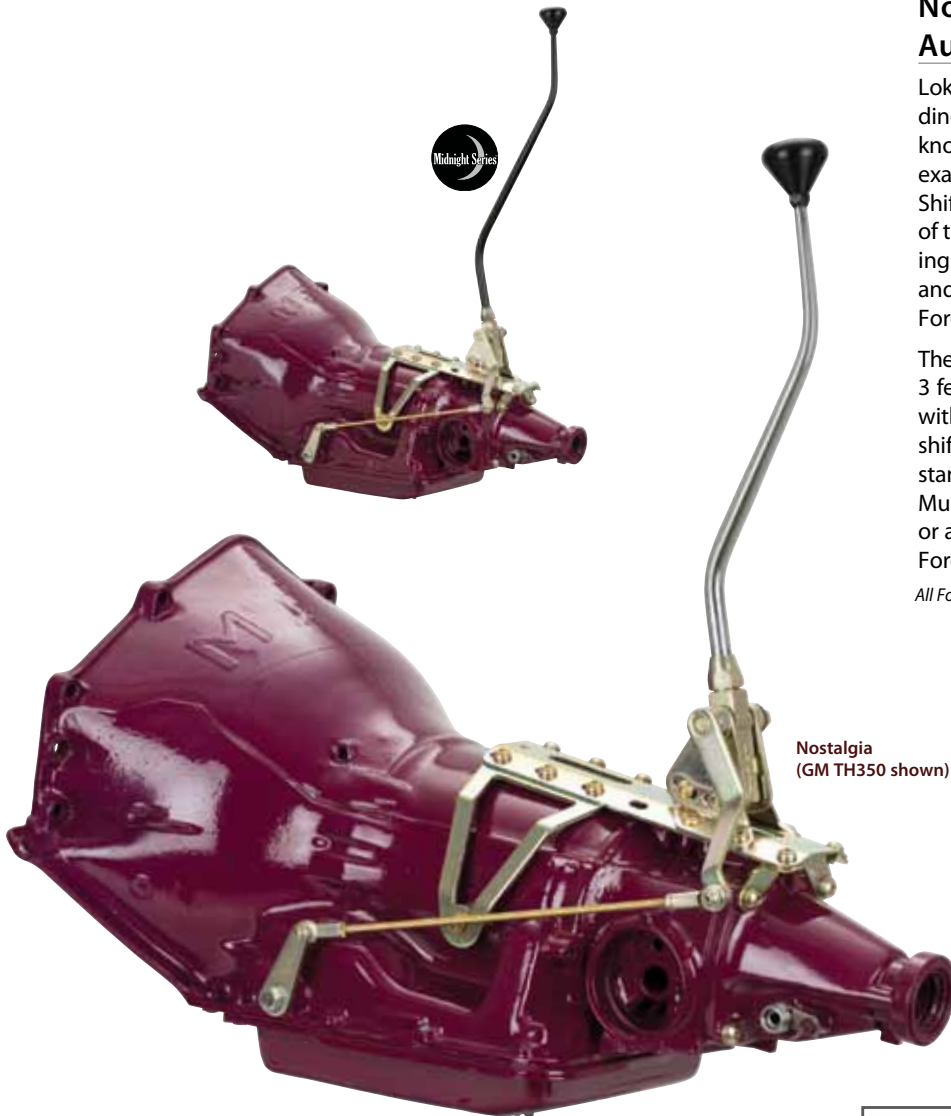

Nostalgia Shifters and "Radical 32" equipped with Black Mushroom Knob. Other knob styles available upon request.

**NOTE:** All Powerglide Shifters are designed for aluminum cases only – cast iron not available.



### TECH NOTE

Shifter lever lengths start 3-1/2" above the top of the transmission. Use this measurement to determine the desired shifter lever length for your vehicle.



### TECH NOTE

Not all shifter detents are created equal. Changing from one type of transmission to another? No problem. Lokar offers Conversion Kits for your convenience and savings.



## 16" Bench Bend Automatic Transmission Shifters

This shifter offers a **NEW BEND** option within the Lokar line of shifters.

This style of lever bend lends itself to vehicles with bench seats such as pickup trucks and muscle cars.

The 16" Bench Bend Shifter is available in our transmission mount, floor mount, tailmount and cable operated shifter applications.

Applications for GM, Ford and Chrysler Automatic Transmissions.

Shifter lever is available in Chrome or Black Finish.

All Ford AOD Shifters require the use of a Lokar Kickdown Kit.

# FLOOR MOUNT & CABLE OPERATED

## Floor Mount Automatic Transmission Shifters

Is your tunnel space too limited to use Lokar's transmission mounted shifter? Consider our Floor Mount Automatic Transmission Shifter. As its name implies, the shifter mounts to the floor on the transmission tunnel using our exclusive mounting brackets. But that's not all – in the name of versatility, Lokar includes three arms for offset mounting (especially helpful when mounting through existing consoles). Even better yet, it retains all the same outstanding features of our transmission mounted shifter. When selecting a shifter boot, Lokar recommends one of our rectangular style Shifter Boots.

### Features

- Operates with solid adjustable linkage
- Utilizes high quality rod ends
- Positive Lock-Out in Park and Neutral
- Neutral Safety Switch
- 360 degree lever rotation for extra leg space
- Lever adjustments for dash and seat clearance
- Levers available in 23", 16", 12", 10", 8" and 6" lengths\*
- Choice of Original Mushroom, Black Anodized Mushroom, Hi-Tech Lokar or Black Anodized Lokar Knob factory installed with shifters\*
- Accessory knobs available separately
- Teflon®-lined shifter knob buttons for smooth operation
- Easy to remove shifter knobs for simple boot installation
- Gold iridited mounting brackets
- All hardware included
- Available for GM, Ford and Chrysler Automatic Transmissions
- Accessory knobs available separately
- Shifter Boots sold separately
- Floor Mount Shifters available in Nostalgia style

*\*Please specify transmission type, lever length and knob style when ordering*

*All Ford AOD Shifters require the use of a Lokar Kickdown Kit.*



Neutral Safety Switch

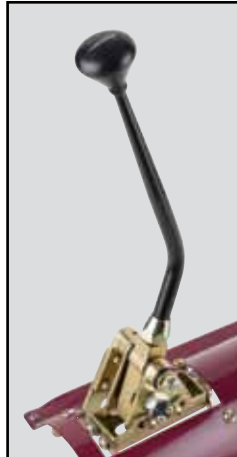

Midnight Series™



Exclusive Lock-Out Button



### ORDERING TIP

Tailmount, Floor Mount and Cable Operated Shifters do not offer the capability of mounting our transmount hand brake.

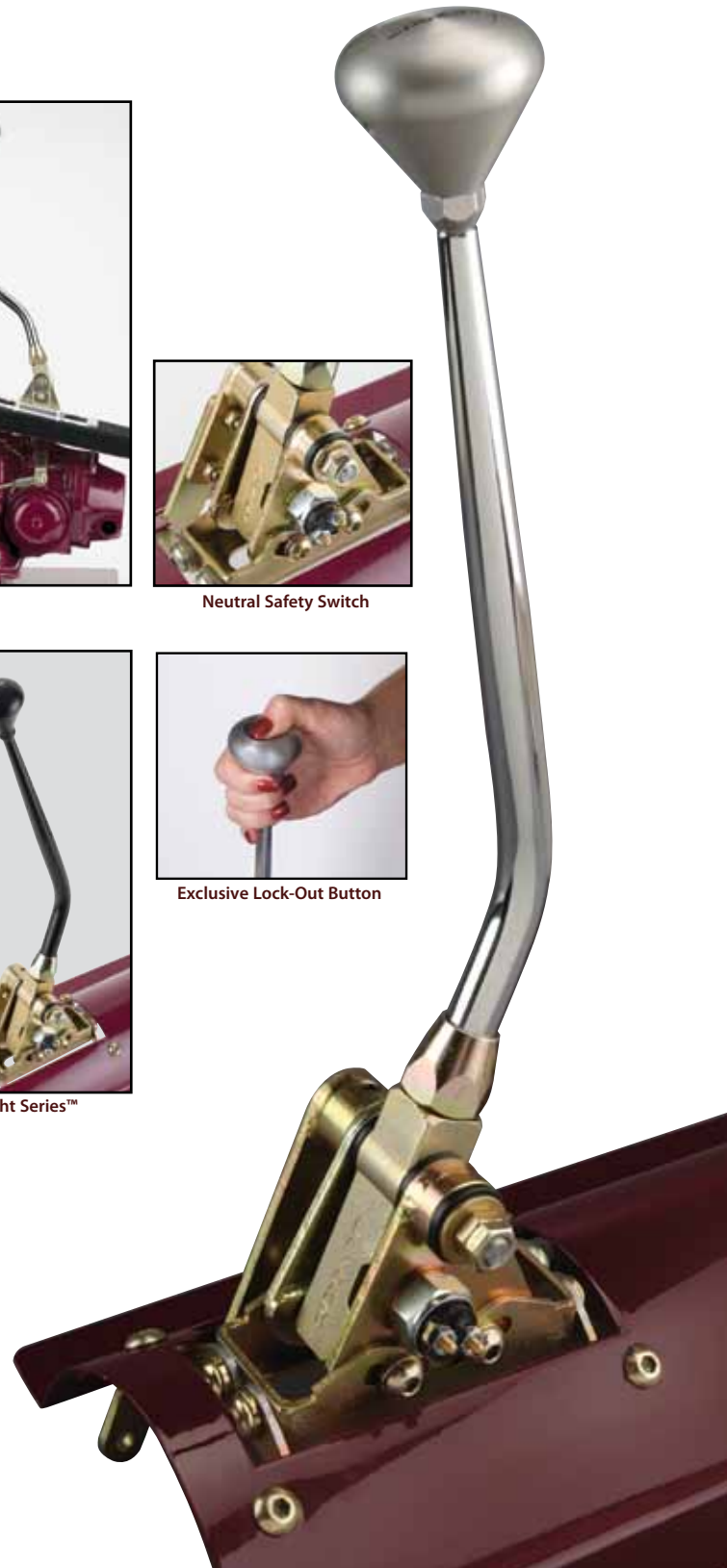

# AUTOMATIC TRANSMISSION SHIFTERS

## Cable Operated Automatic Transmission Shifters

**A**stounding versatility best describes this style of the Lokar Collection of Shifters. Lokar's versatile Floor Mount Shifter is paired with our high quality push/pull cable, offering mounting in virtually any location. This is especially useful when obstructions or personal preference for location are the driving factors upon installation. The use of a durable 1/4" inner cable and spherical rod ends bring this shifter to the next level of quality. User friendly mounting brackets and hardware yields a truly universal product.

### Features

- All the same features of our versatile Floor Mount Design\*
- Operates with high quality 4' push/pull cable with durable 1/4" inner cable
- Spherical rod ends
- Many mounting options
- Cable Operated Shifters available in Nostalgia style

**\*Please specify transmission type, lever length and knob style when ordering**

All Ford AOD Shifters require the use of a Lokar Kickdown Kit.



Midnight Series™



### ORDERING TIP

Use Lokar's Floor Mount Hand Brake or Under-the-Dash Hand Brake with the Tailmount, Floor Mount and Cable Operated Shifters.

# TAILMOUNT AUTOMATIC TRANSMISSION SHIFTERS



Tailmount Bracket shown facing rear



Midnight Series™

Tailmount Bracket shown facing forward

## Tailmount Automatic Transmission Shifters

Don't have room for our transmission mount shifter? You can have the safety and features of a Lokar Shifter with our Tailmount Shifter. This design mounts to the transmission's tailhousing bolts. Our exclusive tailmount bracket gives you a choice of TWO mounting positions... it's the most versatile tailmount shifter available.

### Available for:

GM, Ford, and Chrysler Automatic Transmissions in 12", 10", 8" and 6" lever lengths\*

*\*Please specify transmission type, lever length and knob style when ordering*

*All Ford AOD Shifters require the use of a Lokar Kickdown Kit.*



### ORDERING TIP

Tailmount, Floor Mount and Cable Operated Shifters do not offer the capability of mounting our transmount hand brake.

## Lokar Bell Crank Kits

Lokar Bell Crank Kits are designed for use with Lokar Automatic Transmission Shifters when mounting the shifter all the way forward on the main plate. These kits come complete with all the necessary installation hardware.

Part No.	Description
S-6999	GM TH350, 700-R4 and 4L60 Bell Crank Kit
S-68159	Ford AOD, 4R70W, AODE Bell Crank Kit
S-68161	Ford C4 Bell Crank Kit

S-68159  
Ford AOD/4R70W/AODE  
Bell Crank Kit



S-6999  
GM Bell Crank Kit  
TH350, 700-R4 & 4L60



S-68161  
Ford C4 Bell Crank Kit



(GM TH350 shown)



### Knob and Lever Length Designations

Nostalgia and Radical 32" Shifters are available with either single or double bend levers.

All Nostalgia Shifters, Radical 32" Shifters and Midnight Series™ Shifters are equipped from our factory with Black Mushroom Knobs unless specified otherwise when ordering.

Any Lokar shifter can be ordered as a Midnight Series™ Shifter by adding an "X" to the front of the original shifter part number and specifying the knob style at the end of the part number.

**LOKAR SHIFTER LEVER & KNOB IDENTIFICATION SYMBOLS**

**Lever Lengths:**

- R2 = 32" Double Bend
- R1 = 32" Single Bend
- AN = 23" Nostalgia
- BN = 16" Nostalgia
- A = 23"
- B = 16"
- C = 12"
- D = 10"
- E = 8"
- F = 6"
- G = 16" Bench Bend

**Knobs:**

- M = Mushroom
- MP = Polished Mushroom
- B = Black Anodized Mushroom
- L = Lokar Tapered
- LP = Lokar Polished
- LB = Lokar Black
- P = Piston
- PP = Polished Piston
- 8 = Eight Ball
- S = Skull

**TRANSMISSION SHIFT PATTERNS**

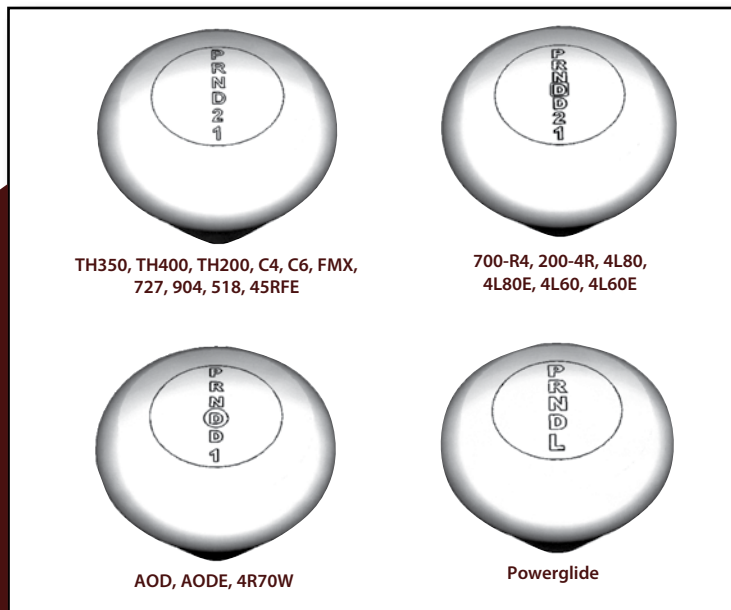

**TRANSMISSION IDENTIFICATION**

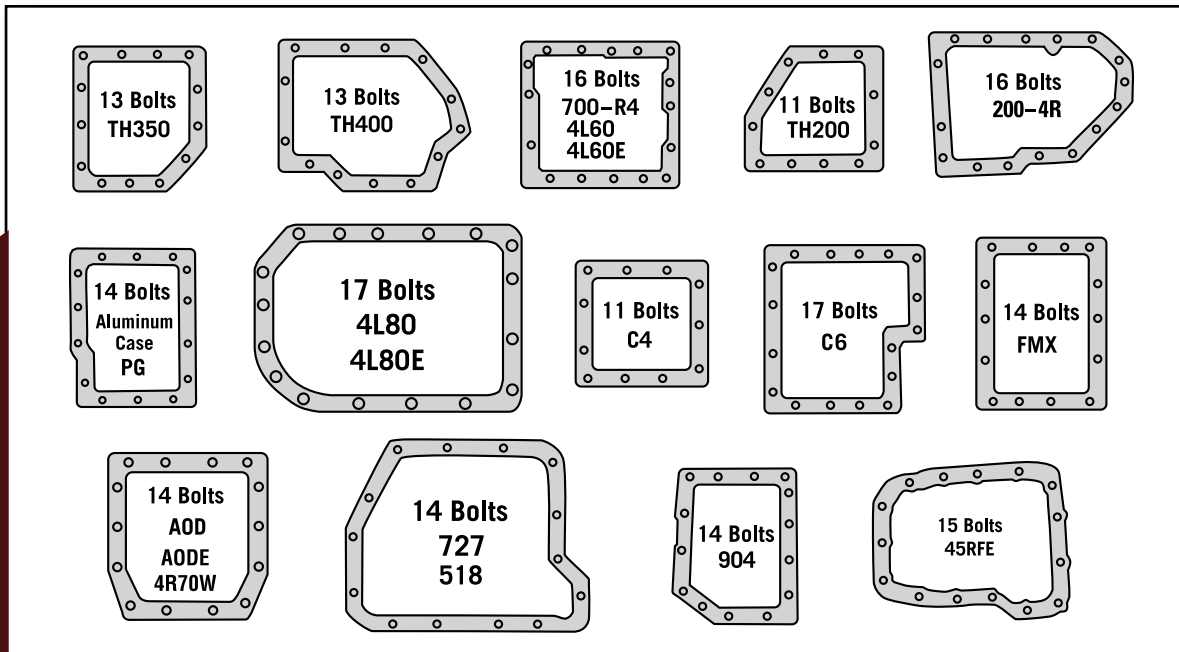

## Lokar Aluminum Shifter Knobs

Smooth operation is guaranteed with our Safety Lock-Out Teflon®-lined button. These easy-to-remove shifter knobs have been designed for simple boot installation. Specify transmission type when ordering to ensure the correct shift pattern\* is provided. Knobs operate with Lokar Shifters only.

\* Engraved shift pattern on knob meets NSRA safety requirements

**Part No. Description**

- SK-6838 3-Speed Automatic Brushed Mushroom Knob
- SK-6839 3-Speed Automatic Black Mushroom Knob
- SK-6840 3-Speed Automatic Brushed Lokar Knob
- SK-6904 3-Speed Automatic Black Lokar Knob
- SK-6841 GM 4-Speed Overdrive Brushed Mushroom Knob
- SK-6842 GM 4-Speed Overdrive Black Mushroom Knob
- SK-6843 GM 4-Speed Overdrive Brushed Lokar Knob
- SK-6906 GM 4-Speed Overdrive Black Lokar Knob
- SK-6844 Powerglide Brushed Mushroom Knob
- SK-6845 Powerglide Black Mushroom Knob
- SK-6846 Powerglide Brushed Lokar Knob
- SK-6909 Powerglide Black Lokar Knob
- SK-6847 Ford AOD, 4R70W, AODE Brushed Mushroom Knob
- SK-6848 Ford AOD, 4R70W, AODE Black Mushroom Knob
- SK-6849 Ford AOD, 4R70W, AODE Brushed Lokar Knob
- SK-6908 Ford AOD, 4R70W, AODE Black Lokar Knob



**Black Lokar Knob**

**Black Mushroom Knob**



**Brushed Mushroom Knob**



**Brushed Lokar Knob**

## Premium Lokar Aluminum Shifter Knobs

All Premium shifter knobs are designed with our Safety Lock-Out Teflon®-lined button and function with the same smooth operation as our original factory installed knobs. All Premium shifter knobs are available with a plain button (no shift pattern) or engraved with a transmission specific shift pattern\* 8-Ball Shifter Knob is machined from Delrin® and is not available with an engraved shift pattern.

\*Engraved shift pattern on knob meets NSRA safety requirements. Premium knobs operate with Lokar Shifters only.



**2" Deco Shift Knobs with Plain Button**



**2" Solid Shift Knobs with Plain Button**



**2" Venetian Shift Knobs with Plain Button**



**Plain buttons available**

**Description Part No.**

<b>Piston Knobs</b>	
3-speed Piston Knob – Polished	SK-6857
GM 4-Speed Overdrive Piston Knob – Polished	SK-6856
Ford AOD, 4R70W, AODE Piston Knob – Polished	SK-6859
Powerglide Piston Knob – Polished	SK-6858
3-speed Piston Knob – Brushed	SK-6851
GM 4-Speed Overdrive Piston Knob – Brushed	SK-6852
Ford AOD, 4R70W, AODE Piston Knob – Brushed	SK-6854
Powerglide Piston Knob – Brushed	SK-6853

<b>Skull Knobs</b>	
3-speed Skull Knob – Polished	SK-6862
GM 4-Speed Overdrive Skull Knob – Polished	SK-6863
Ford AOD, 4R70W, AODE Skull Knob – Polished	SK-6865
Powerglide Skull Knob – Polished	SK-6864
Skull Knob w/Plain Button – Polished	SK-6861

<b>Mushroom Knobs</b>	
3-speed Auto Mushroom Knob – Polished	SK-6860
GM 4-Speed Overdrive Mushroom Knob – Polished	SK-6855
Ford AOD, 4R70W, AODE Mushroom Knob – Polished	SK-6887
Powerglide Mushroom Knob – Polished	SK-6880

<b>Lokar Hi-Tech Knobs</b>	
3-speed Lokar Knob – Polished	SK-6867
GM 4-Speed Overdrive Lokar Knob – Polished	SK-6905
Ford AOD, 4R70W, AODE Lokar Knob – Polished	SK-6907
8-Ball Shifter Knob	SK-6850

<b>Premium Lokar Aluminum Shift Knobs</b>	
2" Solid Round Satin Shift Knob w/Plain Button	SK-6920
2" Solid Round Black Shift Knob w/Plain Button	SK-6921
2" Solid Round Polished Shift Knob w/Plain Button	SK-6922
2" Venetian Satin Shift Knob with Plain Button	SK-6923
2" Venetian Black Shift Knob with Plain Button	SK-6924
2" Venetian Polished Shift Knob with Plain Button	SK-6925
2" Deco Satin Shift Knob with Plain Button	SK-6926
2" Deco Black Shift Knob with Plain Button	SK-6927
2" Deco Polished Shift Knob with Plain Button	SK-6928

## Lokar Shifter Knob Adapter

While personal style is important, at Lokar, "Safety is Never an Extravagance."

To fill the void between personal preference and personal safety, Lokar developed a Shifter Knob Adapter which allows you to express yourself with highly custom knobs, yet still retain all of the safety features and benefits of a Lokar Shifter, including the positive lock-out in Park and Neutral. (See page 2 for all the safety features of our shifters)

After thoughtful consideration and careful planning, Lokar invented a Shifter Knob Adapter with hidden functional parts and a sleek design which will install on ANY Lokar Shifter without modification and allow the use of virtually anything as a knob.

The Adapter is offered with common 3/8"-16 or 3/8"-24 thread sizes and is available in either a chromed or black finish.

### Part No. Description

SK-6878	Shifter Knob Adapter for 3/8"-16 Knob
XSK-6878	Black Shifter Knob Adapter for 3/8"-16 Knob
SK-6879	Shifter Knob Adapter for 3/8"-24 Knob
XSK-6879	Black Shifter Knob Adapter for 3/8"-24 Knob



## Knobs for Lokar Shifter Knob Adapter

- Offered in 2-1/4" diameter
- Plain design (no shift pattern)
- Each knob includes aluminum 3/8"-16 & 3/8"-24 thread inserts and polished jam nuts

### Part No. Description

SK-6882	2 1/4" Plain Ivory Shift Knob 3/8"-16 & 3/8"-24
SK-6883	2 1/4" Plain White Shift Knob 3/8"-16 & 3/8"-24
SK-6884	2 1/4" Plain Black Shift Knob 3/8"-16 & 3/8"-24
SK-6885	2 1/4" Black 8-Ball Shift Knob 3/8"-16 & 3/8"-24
SK-6886	2 1/4" Ivory & Red 8-Ball Shift Knob 3/8"-16 & 3/8"-24
SK-6888	2 1/4" Transparent Red Flamed Shift Knob 3/8"-16 & 3/8"-24
SK-6912	2" Solid Satin Shift Knob 3/8-24 Thread
SK-6913	2" Solid Round Black Shift Knob 3/8-24 Thread
SK-6914	2" Solid Round Polished Shift Knob 3/8-24 Thread
SK-6918	2" Venetian Satin Shift Knob
SK-6916	2" Venetian Black Shift Knob
SK-6919	2" Venetian Polished Shift Knob



## MANUAL SHIFTER ACCESSORIES

### Manual Transmission Shifter Knobs

Shifter knobs for 4-speed, 5-speed and 6-speed manual transmissions are 2" in diameter and include 3/8"-24 and 3/8"-16 thread and polished jam nuts. Engraved with appropriate shift pattern, they are available in Ivory, Black and White. A perfect addition to the Lokar Manual Transmission Shifter Levers.

Part No.	Description
SK-6872	5-Speed Ivory 2" Shift Knob 3/8"-24 & 3/8"-16 Thread
SK-6873	6-Speed Ivory 2" Shift Knob 3/8"-24 & 3/8"-16 Thread
SK-6874	5-Speed White 2" Shift Knob 3/8"-24 & 3/8"-16 Thread
SK-6875	6-Speed White 2" Shift Knob 3/8"-24 & 3/8"-16 Thread
SK-6876	5-Speed Black 2" Shift Knob 3/8"-24 & 3/8"-16 Thread
SK-6877	6-Speed Black 2" Shift Knob 3/8"-24 & 3/8"-16 Thread
SK-6890	4-Speed Ivory 2" Shift Knob 3/8"-24 & 3/8"-16 Thread Reverse Down Left
SK-6891	4-Speed White 2" Shift Knob 3/8"-24 & 3/8"-16 Thread Reverse Down Left
SK-6892	4-Speed Black 2" Shift Knob 3/8"-24 & 3/8"-16 Thread Reverse Down Left
SK-6893	4-Speed Ivory 2" Shift Knob 3/8"-24 & 3/8"-16 Thread Reverse Up Left
SK-6894	4-Speed White 2" Shift Knob 3/8"-24 & 3/8"-16 Thread Reverse Up Left
SK-6895	4-Speed Black 2" Shift Knob 3/8"-24 & 3/8"-16 Thread Reverse Up Left

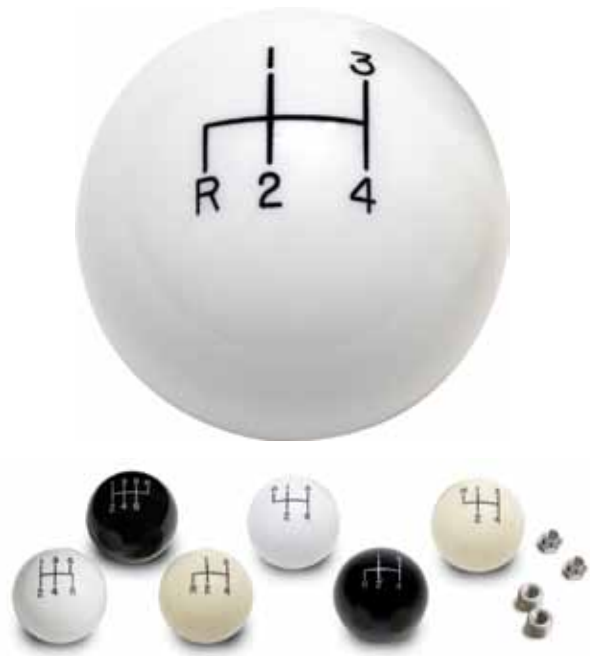

### Chevrolet/GMC S-10 5-Speed Manual Shift Lever Adapter

#### Features

- Replaces factory shifter to adapt to Lokar Manual Shift Lever
- Uses existing factory internal parts
- Fits 1993-2003 NV 3500 Transmission as well as 1995-2003 NV 1500 Transmission
- Requires use of Lokar's T5 Tremec lever
- Fits Lokar's 16", 12" and 10" single bend and 16" double bend Tremec levers offering a variety of lever lengths and knob choices

#### Part No. Description

MSL610 Manual Shift Lever Adapter



## Billet Aluminum Tremec/Borg Warner Shifter Levers

Direct bolt on billet aluminum shifter levers. These levers will fit the Tremec T5, T45, T56 and TKO manual transmissions with the standard 2-bolt flange and give you that clean, smooth appearance.

- Billet Aluminum construction
- Windowed levers complement other Lokar products
- Unique Styling
- Machined groove for boot attachment
- 3/8"-16 Thread for shift knob
- Mounting hardware included
- Available in 6" and 8" straight and also available in 6", 8" and 10" with a single bend.
- Brushed or black finish

### Part No. Description

MSL611D	Billet Aluminum TKO 500-600 & Magnum Manual Shift Lever 10"
XMSL611D	Black Billet Aluminum TKO 500-600 & Magnum Manual Shift Lever 10"
MSL612E	Billet Aluminum TKO 500-600 & Magnum Manual Shift Lever 8"
XMSL612E	Black Billet Aluminum TKO 500-600 & Magnum Manual Shift Lever 8"
MSL613E	Billet Aluminum TKO 500-600 & Magnum Manual Shift Lever 8" Straight
XMSL613E	Black Billet Aluminum TKO 500-600 & Magnum Manual Shift Lever 8" Straight
MSL614F	Billet Aluminum TKO-500-600 & Magnum Manual Shift Lever 6"
XMSL614F	Black Billet Aluminum TKO-500-600 & Magnum Manual Shift Lever 6"
MSL615F	Billet Aluminum TKO 500-600 & Magnum Manual Shift Lever 6" Straight
XMSL615F	Black Billet Aluminum TKO 500-600 & Magnum Manual Shift Lever 6" Straight
MSL616D	Billet Aluminum Tremec/Borg Warner T5, T45, T56 Shift Lever 10"
XMSL616D	Black Billet Aluminum Tremec/Borg Warner T5, T45, T56 Shift Lever 10"
MSL617E	Billet Aluminum Tremec/Borg Warner T5, T45, T56 Shift Lever 8"
XMSL617E	Black Billet Aluminum Tremec/Borg Warner T5, T45, T56 Shift Lever 8"
MSL618E	Billet Aluminum Tremec/Borg Warner T5, T45, T56 Shift Lever 8" Straight
XMSL618E	Black Billet Aluminum Tremec/Borg Warner T5, T45, T56 Shift Lever 8" Straight
MSL619F	Billet Aluminum Tremec/Borg Warner T5, T45, T56 Shift Lever 6"
XMSL619F	Black Billet Aluminum Tremec/Borg Warner T5, T45, T56 Shift Lever 6"
MSL620F	Billet Aluminum Tremec/Borg Warner T5, T45, T56 Shift Lever 6" Straight
XMSL620F	Black Billet Aluminum Tremec/Borg Warner T5, T45, T56 Shift Lever 6" Straight

### Tremec Boots

70-SRB	Round Tremec Boot for Billet Aluminum Levers
70-BFS	Floormount Tremec Boot for Billet Aluminum Levers

**Voted Runner Up  
2011 SEMA Show  
Best New Interior  
Accessory Product**

70-BFS Shown



**Voted Runner Up  
2011 SEMA Show  
Best New Interior  
Accessory Product**



## Manual Transmission Shifter Levers

Direct bolt on tubular shifter levers for Tremec/Borg Warner manual transmissions are built for stock and aftermarket 5 and 6 speed shifters. They fit the TKO, T5, T45, and T56 with the standard 2-bolt flange measuring 7/8" center to center. To give you a clean, smooth appearance, these levers feature a machined billet steel mounting stud counter sunk for cap screws. Tremec/Borg Warner kits include 8mm socket head cap screws and Tremec TKO includes 3/8"-24 socket head cap screws. Levers feature a 3/8"-24 thread for the shift knob and are available in 16", 12" and 10" lengths with a single bend. The 16" lever is also available in a double bend. All levers are available in chromed or black finish.

Description	Chromed	Black Powder Coated
Tremec/Borg Warner, T5, T45, T56 Shift Lever 16"	MSL6B	XMSL6B
Tremec/Borg Warner, T5, T45, T56 Shift Lever 12"	MSL6C	XMSL6C
Tremec/Borg Warner, T5, T45, T56 Shift Lever 10"	MSL6D	XMSL6D
Tremec/Borg Warner, T5, T45, T56 Shift Lever 16" Double Bend	MSL6B2	XMSL6B2
Tremec TKO 500 - 600 & Magnum Shift Lever 16"	MSL601B	XMSL601B
Tremec TKO 500 - 600 & Magnum Shift Lever 12"	MSL602C	XMSL602C
Tremec TKO 500 - 600 & Magnum Shift Lever 10"	MSL603D	XMSL603D
Tremec TKO 500 - 600 & Magnum Shift Lever 16" Double Bend	MSL604B2	XMSL604B2



## FORD AOD SELECTOR SHAFT AND ARM

Lokar's Ford AOD Selector Shaft and Arm is the solution to hunting for the right part. By standardizing the shift linkage for aftermarket applications, Lokar has eliminated the guess work, saving you time and money.

This fully adjustable shaft and arm finally allows for installation on numerous applications.

### Features

- Replaces factory selector shaft and arm
- Adjustable arm simplifies finding the proper ratio between the shifter and the transmission
- Arm designed to be installed in any 360 degree position for versatility
- Kickdown seal installed in selector shaft
- Zinc plated with stainless steel hardware
- Can be used with many aftermarket shifters
- Detailed instructions

All Ford AOD Shifters require the use of a Lokar Kickdown Kit.

### Part No. Description

ATA-1000	Ford AOD Selector Shaft and Arm 1/4" slot and hole
ATA-1001	Ford AOD Selector Shaft and Arm 5/16" slot
ATA-1002	Ford 4R70W/AODE Selector Flange and Arm 1/4" slot and hole
ATA-1003	Ford 4R70W/AODE Selector Flange and Arm 5/16" slot
ATA-1004	Ford 4R70W/AODE Selector Shaft, Flange and Arm 1/4" slot and hole
ATA-1005	Ford 4R70W/AODE Selector Shaft, Flange & Arm 5/16" slot

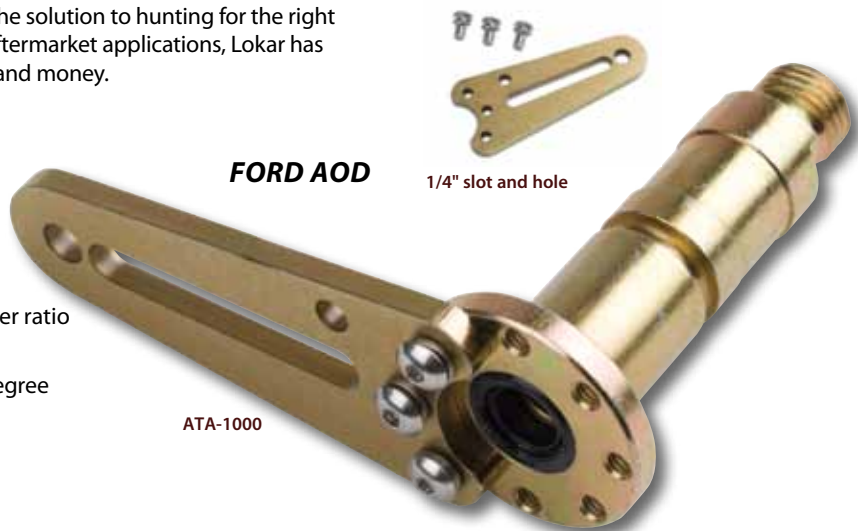

FORD AOD

1/4" slot and hole

ATA-1000



ATA-1001

5/16" slot

### FORD 4R70W/AODE



ATA-1002



ATA-1003



ATA-1004



ATA-1005

## Billet Aluminum Adjustable Trans Shift Arms

### Part No. Description

ACA-1802	Billet Aluminum Adjustable Trans Shift Arm Only TH350, TH400, 700-R4, TH200, 200-4R, 4L60, 4L60E and 4L80E
ACA-1803	Billet Aluminum Adjustable Trans Shift Arm Only Ford C4/C6



ACA-1803  
Ford C4 and C6

ACA-1802  
GM TH350, TH400, 700-R4, TH200,  
200-4R, 4L60, 4L60E and 4L80E

## Back-Up Light or Neutral Safety Switch Kit

This kit offers the choice of Back-Up Light Switch OR Neutral Safety Switch Kit. Kit fits TH350, TH400, 700-R4, TH200, 200-4R, and 4L60 transmissions. Single trigger for back-up light switch, or double trigger for neutral safety switch. KIT WILL NOT PERFORM BOTH FUNCTIONS. All mounting hardware included.

### Part No. Description

BL-1400U	Back-Up Light or Neutral Safety Switch Kit TH350, TH400, 700-R4, TH200, 200-4R and 4L60
----------	--

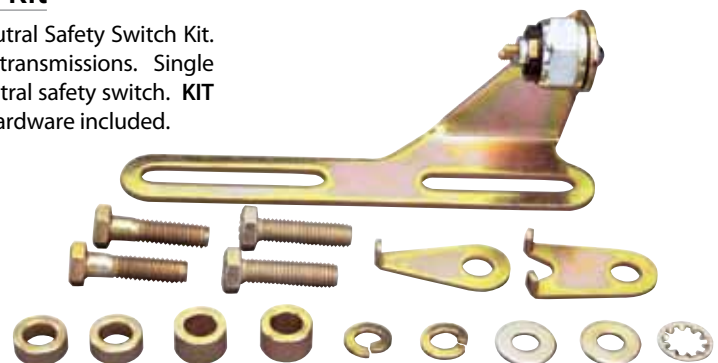

## CABLE OPERATED LED SHIFT INDICATOR KITS

Lokar's Cable Operated LED Shift Indicator is designed for the flexibility to mount it in a variety of locations under the hood such as on the transmission, attached to the frame rail, to the floor pan, on the firewall or on the inner fender well.

Remote Mounting Kit available for those out of the way, distant locations inside the vehicle, such as under the dash, behind the seat or in the trunk.



Ford AOD transmission



Ford AOD transmission

### Features

- Arm and Ball-Milled Sensor Housing CNC machined from 6061-T6 Billet Aluminum
- Programmable Solid State Circuit Board within the decoder box
- Cable operated for flexibility in mounting
- Kit includes 5' of "U-Cut-to-Fit" stainless steel braided housing and 6' of inner control wire
- Back-Up Light circuit built in
- Neutral safety switch built in
- Long Life LED Indicators
- Stainless steel and zinc plated mounting hardware
- Zinc plated Universal Angled Mounting Brackets
- Displays transmission position in engaged gear only
- Color-coded wiring instructions for easy installation
- Compatible for use with all Lokar Automatic Transmission Shifters
- Compatible with many other aftermarket shifters
- Available for most GM, Ford and Chrysler Automatic Transmissions
- Available in Horizontal or Vertical Dash or Boot Mount
- Sensor Kit available separately
- Remote Kit available with 7' of "U-Cut-to-Fit" stainless steel braided housing and 13' of inner control wire and adjustable fitting (Sold Separately)
- Special lengths available upon request



Cable Operated Sensor Kit (Available Separately)

### Sensor and Remote Kits

Transmission	Description	Part No.
GM 350/400/700-R4/4L60	Cable Operated Sensor Kit	CINS-1797
GM 4L60E/4L80E	Cable Operated Sensor Kit (for Long Selector Shaft)	CINS-17002
GM 200-4R	Cable Operated Sensor Kit	CINS-17003
Ford AOD/4R70W/AODE	Cable Operated Sensor Kit	CINS-1798
Ford C4/C6	Cable Operated Sensor Kit	CINS-1799
Chrysler 727/904/518	Cable Operated Sensor Kit	CINS-17001
All Applications	Remote Mounting Cable Kit	CINR-1796

SHIFT INDICATORS

# LED BOOT AND DASH INDICATORS



Dash Indicator – Horizontal Mount  
Each Gear illuminates when engaged



Dash Indicator –  
Vertical Mount



Billet Round Indicator Boot Ring  
Vertical Mount



Billet Round Indicator Boot Ring  
Horizontal Mount



Billet Rectangular Indicator Boot Ring  
Horizontal Mount



Midnight Series™ Billet Rectangular Indicator  
Boot Ring Horizontal Mount



Billet Rectangular Indicator Boot Ring  
Vertical Mount



Midnight Series™ Billet Rectangular Indicator  
Boot Ring Vertical Mount



## Billet Aluminum LED Dash Indicator with Sensor Kit

Transmission	Horizontal Brushed Kit Part No.	Horizontal Black Kit Part No.	Vertical Brushed Kit Part No.	Vertical Black Kit Part No.
350/400	CIND-1715	XCIND-1715	CIND-1716	XCIND-1716
700-R4/4L60	CIND-1717	XCIND-1717	CIND-1718	XCIND-1718
Ford AOD/4R70W/AODE	CIND-1719	XCIND-1719	CIND-1720	XCIND-1720
Ford C4/C6	CIND-1721	XCIND-1721	CIND-1722	XCIND-1722
Chrysler 727/904/518	CIND-1723	XCIND-1723	CIND-1724	XCIND-1724
4L60E/4L80E (Long Selector Shaft)	CIND-1725	XCIND-1725	CIND-1726	XCIND-1726
200-4R	CIND-1727	XCIND-1727	CIND-1728	XCIND-1728

## Billet Aluminum LED Dash Bezels Only

Transmission	Horizontal Brushed Part No.	Horizontal Black Part No.	Vertical Brushed Part No.	Vertical Black Part No.
350/400/200/C4/C6/727/904/518	CIND-1700	XCIND-1700	CIND-1701	XCIND-1701
700-R4/200-4R/4L60/4L60E/4L80E	CIND-1702	XCIND-1702	CIND-1703	XCIND-1703
Ford AOD/4R70W/AODE	CIND-1704	XCIND-1704	CIND-1705	XCIND-1705

## Billet Aluminum LED Boot Indicator with Sensor Kit

ROUND STYLE Transmission	Horizontal Round Brushed Part No.	Horizontal Round Black Part No.	Vertical Round Brushed Part No.	Vertical Round Black Part No.
350/400	CINB-1747	XCINB-1747	CINB-1748	XCINB-1748
700-R4/4L60	CINB-1749	XCINB-1749	CINB-1750	XCINB-1750
Ford AOD/4R70W/AODE	CINB-1751	XCINB-1751	CINB-1752	XCINB-1752
Ford C4/C6	CINB-1753	XCINB-1753	CINB-1754	XCINB-1754
Chrysler 727/904/518	CINB-1755	XCINB-1755	CINB-1756	XCINB-1756
4L60E/4L80E (Long Selector Shaft)	CINB-1757	XCINB-1757	CINB-1758	XCINB-1758
200-4R	CINB-1759	XCINB-1759	CINB-1760	XCINB-1760

RECTANGULAR STYLE Transmission	Horizontal Rectangular Brushed Part No.	Horizontal Rectangular Black Part No.	Vertical Rectangular Brushed Part No.	Vertical Rectangular Black Part No.
350/400	CINB-1779	XCINB-1779	CINB-1780	XCINB-1780
700-R4/4L60	CINB-1781	XCINB-1781	CINB-1782	XCINB-1782
Ford AOD/4R70W/AODE	CINB-1783	XCINB-1783	CINB-1784	XCINB-1784
Ford C4/C6	CINB-1785	XCINB-1785	CINB-1786	XCINB-1786
Chrysler 727/904/518	CINB-1787	XCINB-1787	CINB-1788	XCINB-1788
4L60E/4L80E (Long Selector Shaft)	CINB-1789	XCINB-1789	CINB-1790	XCINB-1790
200-4R	CINB-1791	XCINB-1791	CINB-1792	XCINB-1792

## Billet Aluminum LED Boot Indicator with Boot (w/o Sensor Kit)

ROUND STYLE Transmission	Horizontal Round Brushed Part No.	Horizontal Round Black Part No.	Vertical Round Brushed Part No.	Vertical Round Black Part No.
350/400/200/C4/C6/727/904/518	CINB-1731	XCINB-1731	CINB-1732	XCINB-1732
700-R4/200-4R/4L60/4L60E/4L80E	CINB-1733	XCINB-1733	CINB-1734	XCINB-1734
Ford AOD/4R70W/AODE	CINB-1735	XCINB-1735	CINB-1736	XCINB-1736

RECTANGULAR STYLE Transmission	Horizontal Rectangular Brushed Part No.	Horizontal Rectangular Black Part No.	Vertical Rectangular Brushed Part No.	Vertical Rectangular Black Part No.
350/400/200/C4/C6/727/904/518	CINB-1763	XCINB-1763	CINB-1764	XCINB-1764
700-R4/200-4R/4L60/4L60E/4L80E	CINB-1765	XCINB-1765	CINB-1766	XCINB-1766
Ford AOD/4R70W/AODE	CINB-1767	XCINB-1767	CINB-1768	XCINB-1768

## HI-TOP AND DELUXE TOP SHIFTER BOOTS AND BEZELS

SHIFTER AND HAND BRAKE BOOTS



Hi-Top Shifter Boot  
(Boot Rings sold separately)

### Hi-Top Shifter Boots

Hi-Top Shifter Boots and Bezels complement any interior to produce a sporty modern appearance. These Boots are designed with a choice of threaded Bezels that attach to the top of the shifter lever threads, doubling as a jam nut and completely concealing the shifter lever. Receiver groove for easy boot attachment. Available in 3/8"-24 and 3/8"-16 threads. Boots cover an entire 6" and 8" Lokar shifter lever. Boots available for round or rectangular boot rings. (sold separately) Bezels available in Brushed, Black and Chrome finish.

#### Part No. Description

70-BAR1	Hi-Top Round Boot w/Billet Aluminum Bezel 3/8"-24 Thread
70-BAR2	Hi-Top Round Boot w/Billet Aluminum Bezel 3/8"-16 Thread
70-BAF1	Hi-Top Rectangular Boot w/Billet Aluminum Bezel 3/8"-24 Thread
70-BAF2	Hi-Top Rectangular Boot w/Billet Aluminum Bezel 3/8"-16 Thread
X70-BAR1	Black Hi-Top Round Boot w/Billet Aluminum Bezel 3/8"-24 Thread
X70-BAR2	Black Hi-Top Round Boot w/Billet Aluminum Bezel 3/8"-16 Thread
X70-BAF1	Black Hi-Top Rectangular Boot w/Billet Aluminum Bezel 3/8"-24 Thread
X70-BAF2	Black Hi-Top Rectangular Boot w/Billet Aluminum Bezel 3/8"-16 Thread
70-CR1	Chromed Hi-Top Round Boot with Bezel 3/8"-24 Thread
70-CR2	Chromed Hi-Top Round Boot with Bezel 3/8"-16 Thread
70-CF1	Chromed Hi-Top Rectangular Boot with Bezel 3/8"-24 Thread
70-CF2	Chromed Hi-Top Rectangular Boot with Bezel 3/8"-16 Thread
70-BAB1	Billet Aluminum Boot Bezel 3/8"-24 Thread
70-BAB2	Billet Aluminum Boot Bezel 3/8"-16 Thread
X70-BAB1	Black Billet Aluminum Boot Bezel 3/8"-24 Thread
X70-BAB2	Black Billet Aluminum Boot Bezel 3/8"-16 Thread
70-CBB1	Chromed Boot Bezel 3/8"-24 Thread
70-CBB2	Chromed Boot Bezel 3/8"-16 Thread



X70-BAB1

70-BAB1

70-CBB1

### Deluxe Top Shifter Boots

Deluxe Top Shifter Boots and Sliding Bezels with O-Ring complement any interior to produce a sporty modern appearance. These Boots are designed with a choice of Sliding Bezels with O-Ring so that the boot can be placed anywhere along the length of the shifter lever, allowing a portion of the lever to be exposed. Receiver groove for easy boot attachment. Sliding Bezel is designed for a 5/8" shifter lever. Works with any lever length for personal preference. Boots available for round or rectangular boot rings. (sold separately) Sliding Bezels with O-Ring available in Brushed, Black and Chrome finish

#### Part No. Description

70-BAR3	Deluxe Top Round Boot with 5/8" Billet Aluminum Sliding Bezel
70-BAF3	Deluxe Top Rectangular Boot with 5/8" Billet Aluminum Sliding Bezel
X70-BAR3	Black Deluxe Top Round Boot with 5/8" Billet Aluminum Sliding Bezel
X70-BAF3	Black Deluxe Rectangular Boot with 5/8" Billet Aluminum Sliding Bezel
70-CR3	Chromed Deluxe Top Round Boot with 5/8" Sliding Bezel
70-CF3	Chromed Deluxe Top Rectangular Boot with 5/8" Sliding Bezel
70-BAB3	Billet Aluminum Boot Bezel 5/8" Sliding Bezel
X70-BAB3	Black Billet Aluminum Boot Bezel 5/8" Sliding Bezel
70-CBB3	Chromed Boot Bezel 5/8" Sliding Bezel



X70-BAB3

70-BAB3

70-CBB3



Deluxe Top Shifter Boot  
(Boot Rings sold separately)

# SHIFTER BOOT AND HAND BRAKE BOOT SETS

Lokar Shifter and Hand Brake Boots are made of black Naugahyde. All sets include a boot, stainless base ring, OR billet aluminum ring with ball-milled edge and stainless screws. Stainless boot rings are available in polished stainless or black powder coat. Aluminum boot rings are available in brushed aluminum or black anodized finish.

Our Classic Shifter Boot is designed with a polished stainless bezel on top of the boot which fits over the shifter lever. It also includes a foam rubber seal to eliminate air flow from the floor through the boot.

The Hand Brake Boots are available in transmount or floor mount styles.

All boots hug the shifter lever and there are no unsightly pull ties or laces.

Boot Ring Dimensions		
Description	Outer Dimension	Inner Dimension
Stainless Round Shifter Boot Ring	5"	4"
Stainless Hand Brake Boot Ring	2-1/2" x 6-1/4"	1-1/2" x 5-1/4"
Billet Aluminum Round Shifter Boot Ring	5-1/4"	4"
Billet Aluminum Hand Brake Boot Ring	2-3/4" x 6-1/2"	1-1/2" x 5-1/4"
Stainless Rectangular Floor Mount Shifter Boot Ring	6-3/4" x 5-1/4"	5-1/2" x 4"
Billet Aluminum Rectangular Floor Mount Shifter Boot Ring	6-3/4" x 5-1/4"	5-1/2" x 4"

### Shifter Boot and Hand Brake Boot Kits

Description	Stainless Ring	Billet Ring	Black Anodized Aluminum Ring	Black Stainless Ring
Classic Shifter Boot	70-CLB	70-BCLB	X70-BCLB	X70-CLB
Hot Rod Shifter Boot	70-HRB	70-BHRB	X70-BHRB	X70-HRB
Rectangular Floor Mount Shifter Boot	70-FMB	70-BFMB	X70-BFMB	X70-FMB
Transmount Emergency Hand Brake Boot	70-EHBT	70-BHBT	X70-BHBT	X70-EHBT
Floor Mount Emergency Hand Brake Boot	70-EHBF	70-BHBF	X70-BHBF	X70-EHBF

### Boot Rings Only (includes stainless screws)

Description	Stainless	Billet	Black Anodized Aluminum	Black Stainless
Round Shifter Boot Ring	70-SSR	70-BSR	X70-BSR	X70-SSR
Rectangular Shifter Boot Ring	70-SFR	70-BFR	X70-BFR	X70-SFR
Emergency Hand Brake Boot Ring	70-SHR	70-BHR	X70-BHR	X70-SHR



Midnight Series™ Hot Rod Shifter Boot with Ring Part # X70-HRB



Midnight Series™ Classic Shifter Boot with Ring Part # X70-CLB



Midnight Series™ Rectangular Floor Mount Shifter Boot with Ring Part # X70-FMB



Midnight Series™ Billet Rectangular Shifter Boot Ring with Boot Part # X70-BFMB



Billet Rectangular Floor Mount Shifter Boot Ring with Boot Part # 70-BFMB



Rectangular Floor Mount Shifter Boot with Ring Part # 70-FMB



Classic Shifter Boot with Ring Part # 70-CLB



Hot Rod Shifter Boot with Ring Part # 70-HRB



Hot Rod Shifter Boot with Billet Ring Part # 70-BHRB



Transmount Emergency Hand Brake Boot with Ring Part # 70-EHBT



Billet Hand Brake Boot Ring with Transmount Boot Part # 70-BHBT



Floor Mount Emergency Hand Brake Boot with Ring Part # 70-EHBF

## Hand Brake Boot Sets

SERIALIZED QUALITY PRODUCTION ENGINE ACCESSORIES THROUGH ACCESSORIES SHIFTS AMERICAN TRUCK COMMITMENT TO QUALITY DRAPES PRODUCTION

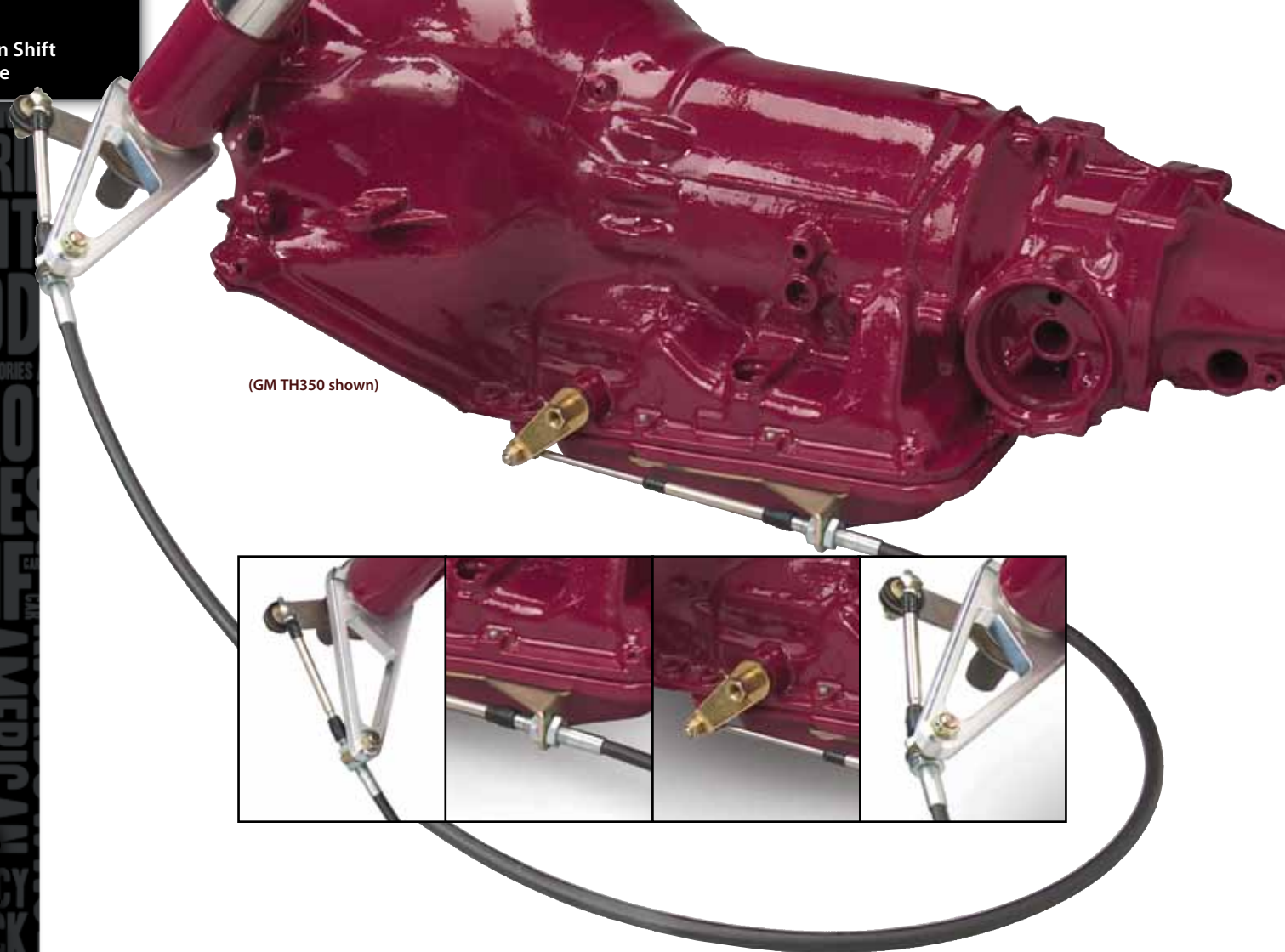

(GM TH350 shown)

### Column Cable Shift Linkage

Lokar's Column Cable Shift Linkage is the ultimate answer to interference issues when you are unable to use factory or Lokar's hard column linkage. The flexibility of the cable allows you to route it around the transmission, cross-members and brake pedals. Our Exclusive Billet Aluminum Mounting Arm can be used on either side of the column. Lokar's Column Cable Shift Kit allows you to use our shift indicator kits. It can also be used in conjunction with our Back-Up Light or Neutral Safety Switch Kit (BL-1400U) for most GM Transmissions. Available in black housing, designed with specially extruded liner for extended life of the cable, and stainless inner wire measuring 6 feet in length. Ready-to-install hardware and brackets included in kit – no cutting or measuring – simply bolts on. **Longer cables are available upon request.**

\*Kits are available for TH350, TH400, 700-R4, TH200, 200-4R, 4L60 and 4L80E (short selector shaft only)

Part No.	Description
ACA-1804	2" aftermarket GM style columns and most GM factory columns*
ACA-1805	2 1/4" aftermarket columns*

\*For all GM Transmissions except Powerglide. Does not fit Ford or Chrysler Transmissions.



#### TECH TIP

If you have a direct line of sight from column shift arm to transmission shift arm, we suggest using our adjustable column shift linkage. (See page 19)

To determine column diameter, measure the lower outer column tube.

## GM & Ford C4/C6 Adjustable Column Shift Linkage

Simplify connecting your column shift to your transmission with a Lokar machined billet aluminum Adjustable Column Shift Linkage Kit. Works with all GM style factory or aftermarket columns. Our rigid, clean line design allows the proper ratio adjustment between the transmission and the indicator on the column.

### Features

- Billet aluminum offers rigidity
- 3/4"-48 spline designed for 360° rotation allowing proper ratio
- Both 3/8"-16 and M10x1.5 threaded nuts for mounting electrical accessories
- Kit includes all hardware, including column bushing and rod ends
- "U-Cut-to-Fit" Stainless Connecting Rod
- Stainless steel connecting rod can be bent for clearance around some obstacles
- No threading necessary
- Fits GM TH350, TH400, 700-R4, TH200, 200-4R, 4L60, 4L60E and 4L80E transmissions
- Fits Ford C4 and C6 transmissions
- Aluminum Adjustable Trans Shift Arms also sold separately

Part No.	Description
ACA-1800	Adjustable Column Shift Linkage TH350, TH400, 700-R4, TH200, 200-4R, 4L60, 4L60E and 4L80E
ACA-1801	Adjustable Column Shift Linkage Ford C4/C6



GM Adjustable Billet Column Arm Kit



GM TH350, TH400, 700-R4, TH200, 200-4R, 4L60, 4L60E and 4L80E applications

Ford C4 and C6 applications

**ORDERING IDEA**  
 You can use our BL-1400U Backup Light or Neutral Safety Switch Kit with GM Column Shift Linkage, except for 4L60E and 4L80E transmissions. (See page 12)

**TECH TIP**  
 If you don't have a direct line of sight between the column shift arm and the transmission shift arm, consider using a column cable shift linkage. (See page 18)

## Ford AOD/4R70W/AODE Adjustable Column Shift Linkage

### Features

- Works with GM style factory or aftermarket columns
- Allows proper ratio adjustment between transmission and indicator on the column
- Kit includes Lokar AOD or 4R70W/AODE Selector Shaft and Arm
- Kit includes all hardware, including bushings and rod ends
- "U-Cut-to-Fit" stainless steel connecting rod
- Stainless steel connecting rod can be bent for clearance around some obstacles
- No threading necessary
- All steel parts are zinc plated
- AOD Selector Shaft and Arm also available separately (see page 12)

All Ford AOD Shifters require the use of a Lokar Kickdown Kit.

Part No.	Description
ACA-1807	Ford AOD Adjustable Column Shift Linkage
ACA-1808	Ford 4R70W/AODE Adjustable Column Shift Linkage



(Ford AOD shown)



Ford AOD

### Oval Billet Aluminum Dash Insert 1932 Ford

Oval Billet Aluminum Dash Insert features recessed face design. Designed to fit original 1932 Ford dash. Styles available for VDO, Classic Instruments, Ford Masterpiece and Auto Meter Gauges. Gauges mount from back of insert. Two green 12 volt turn signal LEDs and one red 12 volt high beam LED included. Holding clips and screws included.

**Gauges not included.** Available in brushed or polished. Dimensions: 11-13/16" x 4-5/8" x 3/4" depth.



Description Gauge Style	1932 Ford Five Gauge Polished Part No.	1932 Ford Five Gauge Brushed Part No.	1932 Ford Two Gauge Polished Part No.	1932 Ford Two Gauge Brushed Part No.
3-1/8" VDO, Auto Meter Street Rod Series, Ford Masterpiece	BDI-9102	BDI-9103		
3-3/8" Classic Instrument Flat Lens only, Low Step Bezel only			BDI-9100	BDI-9101
3-3/8" Classic Instrument Flat Lens only, High Step Bezel only			BDI-9128	BDI-9129

### Oval Billet Aluminum Dash Insert 6 Gauge

Oval Billet Aluminum Dash Insert features recessed face design. Gauges mount from back of insert. Styles available for VDO, Auto Meter, Moon, Stewart Warner, Dolphin, Dakota Digital, Classic Instruments and Ford Motorsports Gauges. Two green 12 volt turn signal LEDs and one red 12 volt high beam LED included. Holding clips and screws included. **Gauges not included.**

Available in brushed or polished.  
Dimensions: 17-3/4" x 4-5/8", 3/4" depth



### Oval Billet Aluminum Dash Insert 5 Gauge

Oval Billet Aluminum Dash Insert features recessed face design. Gauges mount from back of insert. Styles available for VDO, Auto Meter, Moon, Stewart Warner, Dolphin, Dakota Digital, Classic Instruments and Ford Motorsports Gauges. Two green 12 volt turn signal LEDs and one red 12 volt high beam LED included. Holding clips and screws included. **Gauges not included.**

Available in brushed or polished.  
Dimensions: 13-15/16" x 4-5/8", 3/4" depth



Description Gauge Style	5 Gauge Polished Part No.	5 Gauge Brushed Part No.	6 Gauge Polished Part No.	6 Gauge Brushed Part No.
3-1/8" VDO, Auto Meter Street Rod Series, Ford Masterpiece	BDI-9104	BDI-9105	BDI-9106	BDI-9107
3-3/8" VDO, Dakota Digital (including Stewart Warner Winged Series)	BDI-9108	BDI-9109	BDI-9110	BDI-9111
3-3/8" Stewart Warner (excluding Winged Series)	BDI-9112	BDI-9113	BDI-9114	BDI-9115
3-3/8" Auto Meter Traditional and Moon	BDI-9116	BDI-9117	BDI-9118	BDI-9119
3-3/8" Dolphin	BDI-9120	BDI-9121	BDI-9122	BDI-9123
3-3/8" Classic Instruments Flat Lens only, Low Step Bezel only	BDI-9124	BDI-9125	BDI-9126	BDI-9127
3-3/8" Classic Instrument Flat Lens only, High Step Bezel only	BDI-9130	BDI-9131	BDI-9132	BDI-9133

INTERIOR ACCESSORIES



Oval Billet  
Interior Door Handle



Interior Door Handles  
complete with hardware

### Oval Billet Aluminum Interior Door Handles

- Recessed mounting design
- Complete with mounting back plate and hardware
- Rubber trigger stop provides quiet return of lever
- Available in brushed, polished or black finish

**Part No.**    **Description**

IDH-2000	Oval Billet Aluminum Interior Door Handles (Pair) - Brushed
IDH-2001	Oval Billet Aluminum Interior Door Handles (Pair) - Polished
XIDH-2000	Oval Billet Aluminum Interior Door Handles (Pair) - Black



Polished Oval Billet Aluminum  
Interior Door Handle



Brushed Oval Billet Aluminum  
Interior Door Handle

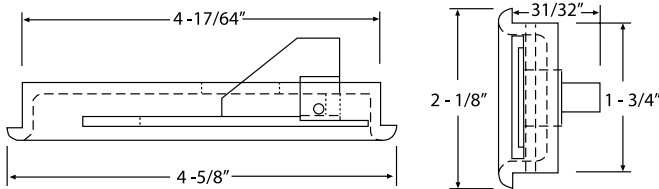

### Universal Door Latch Cable Release Kit

- Shielded pulley for a more direct pulling angle
- "U-Cut-to-Fit" stainless steel cable wire 36"
- Adjustable cable connection
- Eliminates solid rods and bell cranks
- Compatible with bear claw style latches

**Part No.**    **Description**

DLR-2100	Universal Door Latch Cable Release Kit (Pair)
----------	---

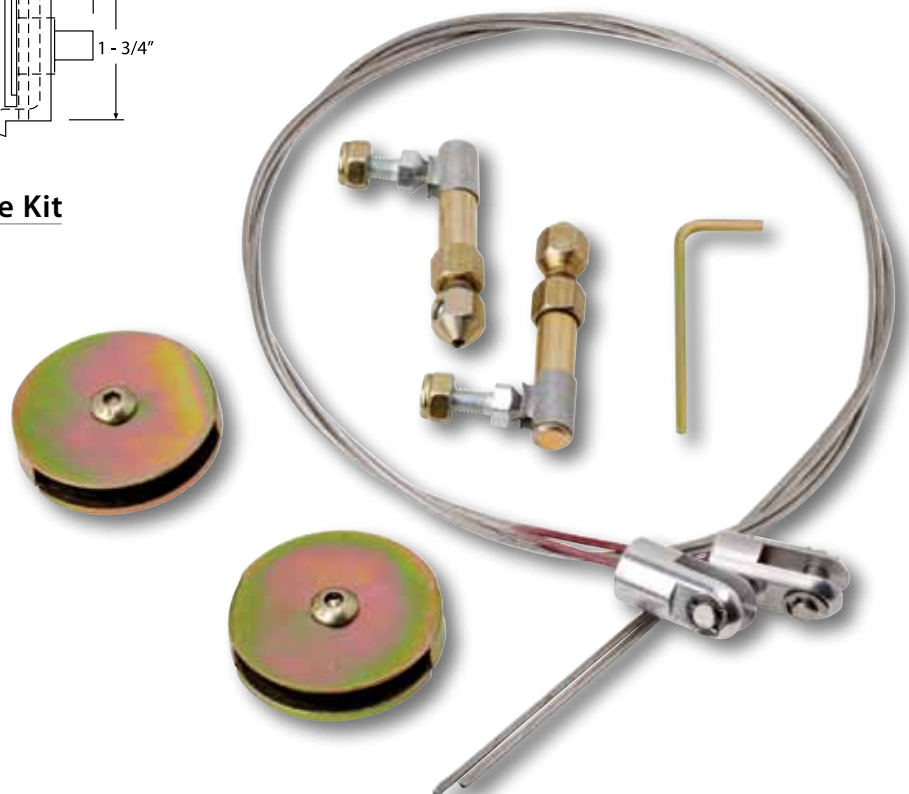



Polished

### Billet Aluminum Door Handles, Window Cranks & Vent Window Cranks

- Splined Arms for fine adjustment
- Available for most GM and Ford Applications
- Windowed Arms match other quality Lokar products
- Hidden set screws
- Available in brushed, polished or black finish



Full 360 degree  
fine spline adjustment



GM Pre 1949

Ford  
Pre 1949

GM & Ford  
1949 & Later



Brushed

Midnight Series™



Brushed

Midnight Series™



Brushed

Midnight Series™

#### Door Handles (Pair)

Part No.	Description	Finish
IDH-2006	GM Pre-1949	Brushed
IDH-2007	GM Pre-1949	Polished
XIDH-2006	GM Pre-1949	Black
IDH-2008	GM & Ford 1949 & Later	Brushed
IDH-2009	GM & Ford 1949 & Later	Polished
XIDH-2008	GM & Ford 1949 & Later	Black
IDH-2010	Ford Pre-1949	Brushed
IDH-2011	Ford Pre-1949	Polished
XIDH-2010	Ford Pre-1949	Black

#### Window Cranks (Pair)

Part No.	Description	Finish
IDH-2012	GM Pre-1949	Brushed
IDH-2013	GM Pre-1949	Polished
XIDH-2012	GM Pre-1949	Black
IDH-2014	GM & Ford 1949 & Later	Brushed
IDH-2015	GM & Ford 1949 & Later	Polished
XIDH-2014	GM & Ford 1949 & Later	Black
IDH-2016	Ford Pre-1949	Brushed
IDH-2017	Ford Pre-1949	Polished
XIDH-2016	Ford Pre-1949	Black

#### Vent Window Cranks (Pair)

Part No.	Description	Finish
IDH-2018	GM Pre-1949	Brushed
IDH-2019	GM Pre-1949	Polished
XIDH-2018	GM Pre-1949	Black
IDH-2020	GM & Ford 1949 & Later	Brushed
IDH-2021	GM & Ford 1949 & Later	Polished
XIDH-2020	GM & Ford 1949 & Later	Black
IDH-2022	Ford Pre-1949	Brushed
IDH-2023	Ford Pre-1949	Polished
XIDH-2022	Ford Pre-1949	Black





### Lakester Door Handles, Window Cranks & Vent Window Cranks

- Nostalgia Styling
- Steel Splined Arms for full 360 degree fine adjustment
- Hidden set screws
- Available in chrome, black and raw finish
- Matches Lakester Throttle Pedal and Brake Pedal sets (page 45)
- Available for most GM and Ford applications



#### Door Handles (Pair)

Part No.	Description	Finish
IDH-2024	GM Pre-1949	Chromed
IDH-2027	GM Pre-1949	Raw
XIDH-2024	GM Pre-1949	Black
IDH-2025	GM & Ford 1949 & Later	Chromed
IDH-2028	GM & Ford 1949 & Later	Raw
XIDH-2025	GM & Ford 1949 & Later	Black
IDH-2026	Ford Pre-1949	Chromed
IDH-2029	Ford Pre-1949	Raw
XIDH-2026	Ford Pre-1949	Black

#### Window Cranks (Pair)

Part No.	Description	Finish
IDH-2030	GM Pre-1949	Chromed
IDH-2033	GM Pre-1949	Raw
XIDH-2030	GM Pre-1949	Black
IDH-2031	GM & Ford 1949 & Later	Chromed
IDH-2034	GM & Ford 1949 & Later	Raw
XIDH-2031	GM & Ford 1949 & Later	Black
IDH-2032	Ford Pre-1949	Chromed
IDH-2035	Ford Pre-1949	Raw
XIDH-2032	Ford Pre-1949	Black

#### Vent Window Cranks (Pair)

Part No.	Description	Finish
IDH-2036	GM Pre-1949	Chromed
IDH-2039	GM Pre-1949	Raw
XIDH-2036	GM Pre-1949	Black
IDH-2037	GM & Ford 1949 & Later	Chromed
IDH-2040	GM & Ford 1949 & Later	Raw
XIDH-2037	GM & Ford 1949 & Later	Black
IDH-2038	Ford Pre-1949	Chromed
IDH-2041	Ford Pre-1949	Raw
XIDH-2038	Ford Pre-1949	Black

## Billet Aluminum Door Pulls

- Two screw installation, Stainless Screws included
- Deep pocket - 4 finger width
- Designed to recess in arm rest
- Mounting bracket included
- Sold in pairs
- Complements Lokar Door Handles, Pedals and Dash Inserts
- Available in brushed, polished or black finish

Part No.	Description	Finish
IDP-2004	Oval Arm Rest Door Pull	Brushed
IDP-2005	Oval Arm Rest Door Pull	Polished
XIDP-2004	Oval Arm Rest Door Pull	Black
IDP-2002	Crescent Oval Arm Rest Door Pull	Brushed
IDP-2003	Crescent Oval Arm Rest Door Pull	Polished
XIDP-2002	Crescent Oval Arm Rest Door Pull	Black



Brushed Oval Billet Arm Rest Door Pull

Polished Oval Billet Arm Rest Door Pull

Midnight Series™ Oval Arm Rest Door Pull

Midnight Series™ Crescent Oval Arm Rest Door Pull



Brushed Crescent Oval Billet Arm Rest Door Pull

Polished Crescent Oval Billet Arm Rest Door Pull

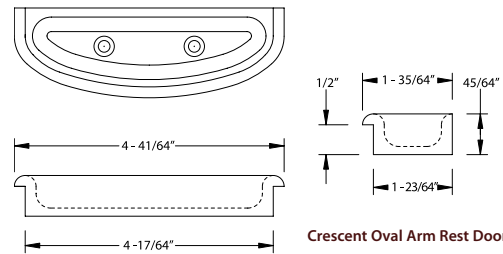

Crescent Oval Arm Rest Door Pull

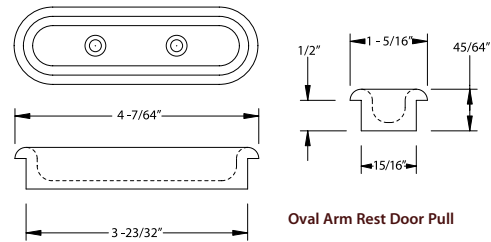

Oval Arm Rest Door Pull



## Billet Aluminum Column Ware™

3-piece Seamless Steering Column Dress-Up Kit. Unique one-piece solid billet aluminum design. Kit includes Turn Signal Lever, Tilt Steering Lever and Emergency Flasher Knob. Kit fits all GM, 1969 through 1976 Chrysler, and all aftermarket columns with single screw design. Appearance is smooth and sleek and adds class and style to any column.

Part No.	Description
DUK-2200	Steering Column Dress-Up Kit - Brushed
DUK-2201	Steering Column Dress-Up Kit - Polished
XDUK-2200	Steering Column Dress-up Kit - Black



# HOOD AND TRUNK RELEASE CABLE KITS

## Combination Hood & Trunk Release Cable Kits

Billet aluminum handle assembly for both the hood and trunk. The cables are "U-Cut-to-Fit", designed with specially extruded liner for extended life of the cable, with aluminum fittings and stainless steel inner wire. Hood release includes aluminum firewall fittings and cable stop. Outer housing is 18 inches inside the vehicle and 6 feet under the hood. Inner wire is 9 feet long. Trunk release includes cable stop. The outer housing is 15 feet long and the inner wire is 16 feet long. Requires cable-operated latches.



CHT-1300U

**Part No.**      **Description**

CHT-1300HT	Combination Hood & Trunk Release Cable Kit – Stainless Housing - Brushed
XCHT-1300HT	Combination Hood & Trunk Release Cable Kit – Stainless Housing - Black
CHT-1300U	Combination Hood & Trunk Release Cable Kit – Black Housing - Brushed
XCHT-1300U	Combination Hood & Trunk Release Cable Kit – Black Housing - Black



XCHT-1300U



CHT-1300HT

Right hand kits available upon request.

## Trunk Release Cable Kits

Kit comes complete with billet aluminum handle assembly and cables. The cables are "U-Cut-to-Fit", designed with specially extruded liner for extended life of the cable, with billet aluminum fittings and stainless steel inner wire. Trunk release kit includes cable stop, 15 feet of outer housing and 16 feet of inner wire. Requires cable-operated latches.



TR-1200U

HR-1100U

**Part No.**      **Description**

TR-1200HT	Trunk Release Cable Kit – Stainless Housing - Brushed
XTR-1200HT	Trunk Release Cable Kit – Stainless Housing - Black
TR-1200U	Trunk Release Cable Kit – Black Housing - Brushed
XTR-1200U	Trunk Release Cable Kit – Black Housing - Black

Right hand kits available upon request.

## Hood Release Cable Kits

Kit comes complete with billet aluminum handle assembly and cables. The cables are "U-Cut-to-Fit", designed with specially extruded liner for extended life of the cable, with billet aluminum fittings and stainless steel inner wire. Hood release kit includes aluminum firewall fittings and cable stop. The cable housing is 18 inches inside the vehicle and 6 feet under the hood. The inner wire is 9 feet long. Requires cable-operated latches.



XTR-1200U

XHR-1100U



TR-1200HT

HR-1100HT

**Part No.**      **Description**

HR-1100HT	Hood Release Cable Kit – Stainless Housing - Brushed
XHR-1100HT	Hood Release Cable Kit – Stainless Housing - Black
HR-1100U	Hood Release Cable Kit – Black Housing - Brushed
XHR-1100U	Hood Release Cable Kit - Black Housing - Black

Right hand kits available upon request.

## Award Winning

### Under-the-Dash Foot Operated Emergency Brake

**NSRA BEST NEW PRODUCT** Lokar Under-the-Dash Foot Operated Emergency Brake features the same superior craftsmanship you have come to expect of all our products. This foot brake gives you ease of operation along with a clean, out of the way emergency brake.

#### Features

- Adjustable 9" to 13" firewall to dash
- Length of the arm measures 10" from the pivot point to the bottom of the foot pad.
- Dash to firewall adjustable bracketry
- Various location mounting capability
- Heat treated gears
- Hidden gears and mechanisms for clean finish
- Rubber stop for quiet pedal return
- Application for finished and unfinished cars
- Complete with instructions and all hardware
- Connector Cables sold separately (See page 31)
- Available in brushed, chromed or black finish

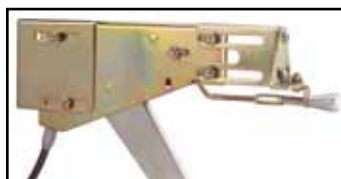

"U-Cut-to-Fit" Release Rod L-Brackets for dash to firewall adjustments

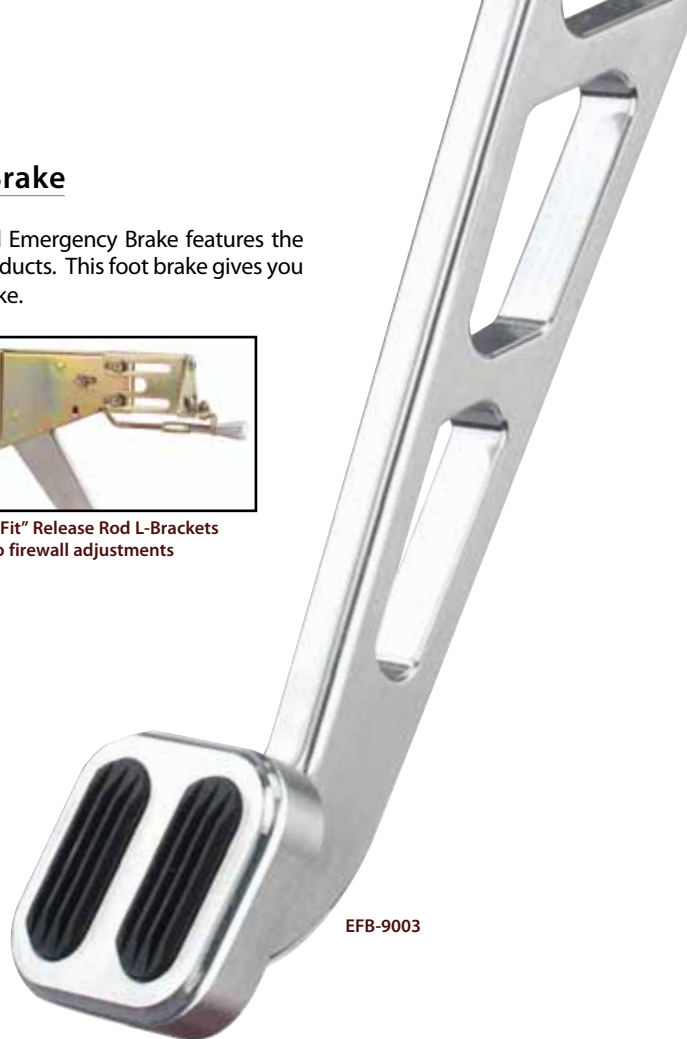

EFB-9003



#### TECH NOTE

Use EC-8001U or EC-8001HT Connector Cable.



#### ORDERING IDEA

The windowed arm and foot pads coordinate with the Lokar Pedals.

#### Part No. Description

EFB-9000	Billet Aluminum Foot Brake with solid arm and ball-milled pad – Brushed
XEFB-9000	Billet Aluminum Foot Brake with solid arm and ball-milled pad – Black
EFB-9001	Billet Aluminum Foot Brake with solid arm and rubber insert in pad – Brushed
XEFB-9001	Billet Aluminum Foot Brake with solid arm and rubber insert in pad – Black
EFB-9002	Billet Aluminum Foot Brake with windowed arm and ball-milled pad – Brushed
EFB-9003	Billet Aluminum Foot Brake with windowed arm and rubber insert in pad – Brushed
XEFB-9003	Billet Aluminum Foot Brake with windowed arm and rubber insert in pad – Black
EFB-9004	Billet Aluminum Foot Brake with solid arm and ball-milled pad – Chromed
EFB-9005	Billet Aluminum Foot Brake with solid arm and rubber insert in pad – Chromed
EFB-9006	Billet Aluminum Foot Brake with windowed arm and ball-milled pad – Chromed
EFB-9007	Billet Aluminum Foot Brake with windowed arm and rubber insert in pad – Chromed
EFB-9008	Billet Aluminum Foot Brake with solid arm and Oval pad with rubber – Brushed
XEFB-9008	Billet Aluminum Foot Brake with solid arm and Oval pad with rubber – Black
EFB-9009	Billet Aluminum Foot Brake with windowed arm and Oval pad with rubber – Brushed
XEFB-9009	Billet Aluminum Foot Brake with windowed arm and Oval pad with rubber – Black
EFB-9010	Billet Aluminum Foot Brake with windowed arm and Oval pad with rubber – Chromed
EFB-9011	Billet Aluminum Foot Brake with solid arm and Oval pad with rubber – Chromed

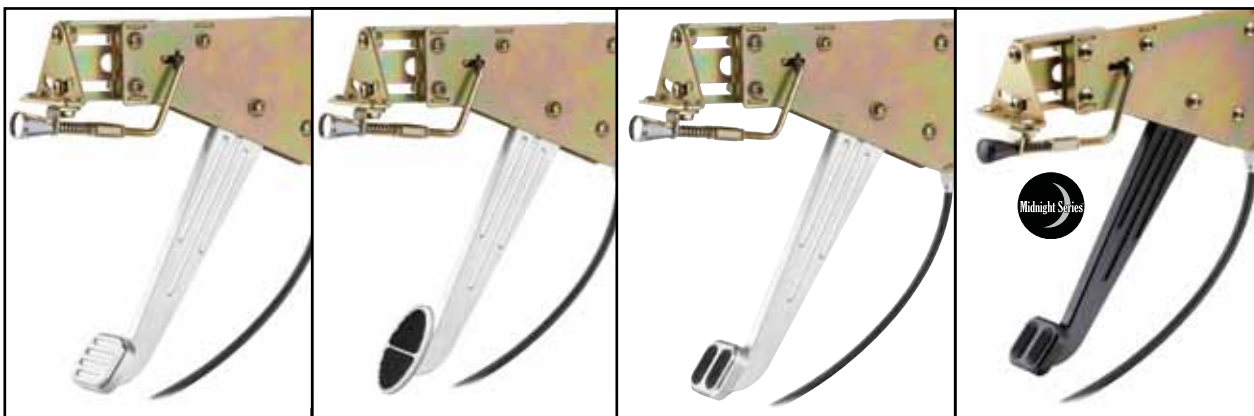
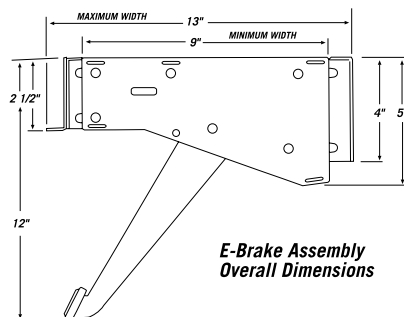

EFB-9000

EFB-9008

EFB-9001

XEFB-9001



## Under-the-Dash Hand Operated Emergency Brake

Lokar's Under-the-Dash Hand Operated Emergency Brake gives you ease of operation along with a clean, out of the way emergency brake. There are no cables entering through the firewall. It fits in a space as small as 11" from the firewall to dash. Ratchet cut gear plate and lock are heat treated for strength and safety. The lever has been designed with durability in mind. The one piece design of the lever with a pistol grip and trigger allows for comfortable lever operation.

### Features

- Adjustable from 11" to 15" firewall to dash
- Length of the arm measures 13" from the pivot point to the bottom of the grip
- Dash to firewall adjustable bracketry
- Various location mounting capability
- Simple installation with universal mounting system
- Pistol grip with trigger release
- No welding necessary
- Complete with instructions and all hardware
- Gold iridited brackets
- Connector Cables sold separately
- Available in brushed, chromed or black finish

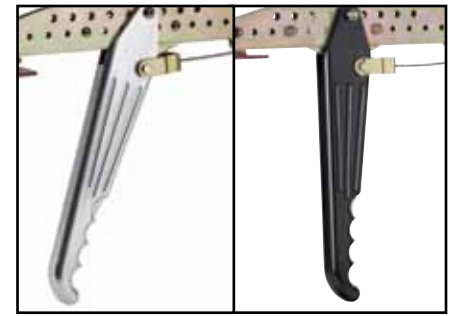

Comfortable lever operation

Midnight Series™



### TECH NOTE

Use EC-8001U or EC-8001HT Connector Cable.

### Part No. Description

EHB-9200	Billet Aluminum Under-the-Dash Hand Operated Emergency Brake - Brushed
XEHB-9200	Billet Aluminum Under-the-Dash Hand Operated Emergency Brake - Black
EHB-9201	Billet Aluminum Under-the-Dash Hand Operated Emergency Brake - Chromed

## Transmount Emergency Hand Brake

Transmount Emergency Hand Brake is designed after the automotive industry standard. Ratchet cut gear plate and lock are heat treated for strength and safety. The geometrical design of the lever allows for comfortable lever operation. Levers are available in chromed steel or black powder coated steel and come in 11" and 16" lengths to complement Lokar's Automatic Transmission Shifter. Mounting hardware for use with Lokar Automatic Transmission Shifter is included with Transmount Cable Kits and is used with the built-in mounting bracketry included with the shifter kits.

### Part No. Description

EHB-7011	11" Transmount Emergency Hand Brake - Chromed
XEHB-7011	11" Transmount Emergency Hand Brake - Black
EHB-7016	16" Transmount Emergency Hand Brake - Chromed
XEHB-7016	16" Transmount Emergency Hand Brake - Black



### ORDERING IDEA

Use 11" hand brake with 16" and shorter shifters; use 16" hand brake with 23" and taller shifters.



### ORDERING TIP

Use Transmount Emergency Brake Cables



11" Transmount Hand Brake shown



Midnight Series™ 16" Transmount Hand Brake shown



Transmount Hand Brake and rear cable hook-up to show mounting application only. Cables sold separately.



## Floor Mount Emergency Hand Brake

**F**loor Mount Emergency Hand Brake is designed after the automotive industry standard. Ratchet cut gear plate and lock are heat treated for strength and safety. Available in chromed steel or black powder coated steel. Special feature includes 4-point mounting capabilities for floor mount or side mounting for personal applications. Comes complete with clevis for installation with Lokar Emergency Brake Cables. Cables are sold separately. Lever has been designed with durability in mind. Hand Brake measures 10" from end to end.

Part No.	Description
EHB-7000F	Floor Mount Emergency Hand Brake - Chromed
XEHB-7000F	Floor Mount Emergency Hand Brake - Black



Hand brake and rear cable hook-up to show mounting application only. Cables sold separately.

**INSTALL TIP**  
Ever think about mounting the floor mount hand brake sideways in front of your seat? You can!

**ORDERING TIP**  
Use our EC-80FU or EC-80FHT cables only.

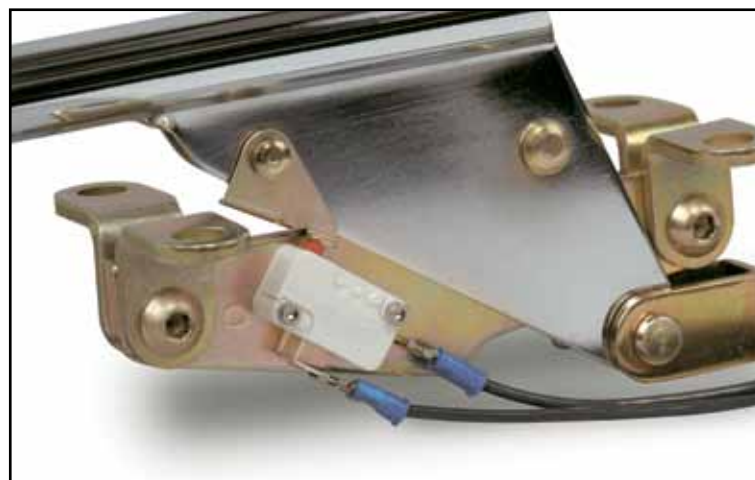

Warning Indicator mounted on Floor Mount Hand Brake. Items sold separately.



## Emergency Brake Warning Indicator Switch Kit

Tired of driving off with your brake on? Then it's time to check out the Lokar Emergency Brake Warning Indicator Switch Kit. The Emergency Brake Warning Switch Kit operates your dash light or buzzer to alert you when your emergency brake is engaged.

Designed for use with the Lokar Floor Mount Hand Brake, Part No. EHB-7000F and XEHB-7000F. Switch mounts to existing holes in gear plate on Floor Mount Hand Brake.

### Kit Includes:

- Micro Switch
- Warning indicator trigger
- Two electrical terminals
- E-clip and pin
- Two stainless mounting bolts
- Two Nylock nuts

Part No.	Description
EHB-7001	Emergency Brake Warning Indicator Switch Kit

## Universal Emergency Brake Cables

Kit is designed for use with Lokar's Floor Mount Emergency Hand Brake, and in conjunction with Lokar's Connector Cables. Kit comes equipped with quality one-piece aluminum adjusters and aluminum ferrule to eliminate fraying of stainless housing. Outer housing is designed with specially extruded liner for extended life of the cable. Stainless inner cable resists moisture. Design allows rear end backing plate fittings to be removed without removing brake cables. Lokar cables also feature adjustable cable lock and clevis. Kit is complete with cable bracket and spacers. Kit includes two 8 foot outer housings that "U-Cut-to-Fit" and are available in stainless or black housing. Application fits 8" and 9" Ford, Chevy, Chrysler and Lincoln Versailles drum and disc brakes. See chart for additional brake applications.

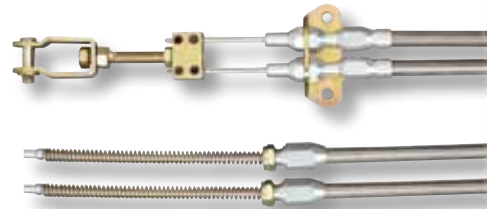

EC-80FHT Stainless Housing



EC-80FU Black Housing

Part No.	Description
EC-80FU	Universal Emergency Brake Cables - Black Housing
EC-80FHT	Universal Emergency Brake Cables - Stainless Housing
EC-80JAGU	Jag Rear Brake Cables - Black Housing (specify year and model)
EC-80JAGHT	Jag Rear Brake Cables - Stainless Housing (specify year and model)
EC-80FUTB	T-Bird Brake Cables - Black Housing
EC-80FHTTB	T-Bird Brake Cables - Stainless Housing
EC-81FU	Ford Explorer/Wilwood Explorer Style Rear Disc Cable Kit - Black Housing (clevises included)
EC-81FHT	Ford Explorer/Wilwood Explorer Style Rear Disc Cable Kit - Stainless Housing (clevises included)



### INSTALL TIP

Always use anti-seize on aluminum fittings to avoid galling.

### APPLICATION CHART

Emergency Brake Application	EC-80FU EC-80FHT	EC-80JAGU EC-80JAGHT	EC-81FU EC-81FHT	EC-80CC	EC-80FUTB EC-80FHTTB	EC-80WC
Chevy Drum	•					
Ford Drum	•					
Chrysler Drum	•					
Dana Drum	•					
Lincoln Versailles	•					
1988 & Later Corvette	•					•
Late Model T-Bird '87 to '88					•	
Ford Explorer & Motorsports Disc w/Internal Drum E-Brake			•			
Jag Rear-End		•				
Jag Rear-End w/Wilwood Brakes	•					•
Wilwood Disc w/Internal Drum E-Brake			•			
Corvette '84 to '87	•			•		
Wilwood Disc Stand Alone E-Brake Caliper	•					•
Baer Brakes	•			•		
SSBC Standard Calipers					•	
SSBC w/Integrated E-Brake	•					•
SSBC w/Stand Alone E-Brake Caliper	•					•

EMERGENCY BRAKE CABLES & CONNECTOR CABLES

## Transmount Emergency Brake Cables

Transmount Cable Kit is designed for use with Lokar's Transmount Emergency Hand Brake and includes bracket for mounting cables to hand brake. Kit comes equipped with quality one-piece aluminum adjusters and aluminum ferrule to eliminate fraying of stainless housing. Outer housing is designed with specially extruded liner for extended life of the cable. Stainless steel inner cable resists moisture. Design allows rear end backing plate fittings to be removed without removing brake cables. Lokar cables also feature adjustable cable lock and clevis. Kit includes two 8 foot outer housings that "U-Cut-to-Fit" and are available in stainless housing or black housing. Application fits 8" and 9" Fords, Chevy, Chrysler and Lincoln Versailles drum and disc brakes. See chart on page 29 for additional brake applications.

Part No.	Description
EC-80TU	Transmount Brake Cables - Black Housing
EC-80THT	Transmount Brake Cables - Stainless Housing
EC-80TUTB	Transmount T-Bird Brake Cables - Black Housing
EC-80HTTB	Transmount T-Bird Brake Cables - Stainless Housing
EC-81TU	Ford Explorer Transmount - Black Housing
EC-81THT	Ford Explorer Transmount - Stainless Housing



Application illustration only. Cables, Hand Brake and Shifter sold separately.

**INSTALL TIP**  
Always use anti-seize on aluminum fittings to avoid galling.

**TECH TIP**  
For use with Lokar Transmount Emergency Hand Brake only.

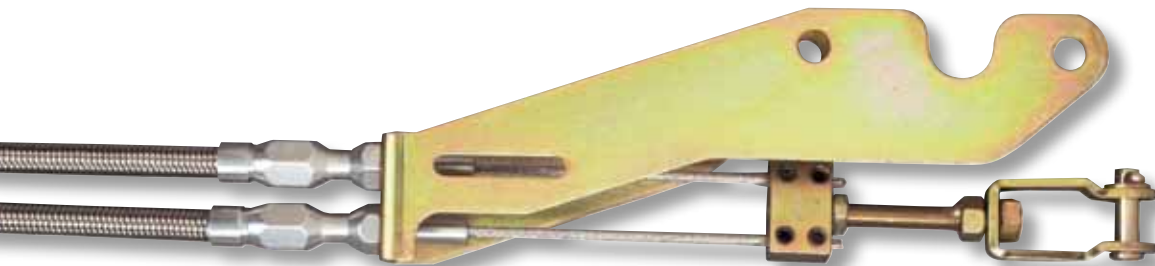

EC-80THT



EC-80TU



## Connector Cables for Under-the-Dash Foot Operated and Hand Operated Emergency Brakes

Lokar Connector Cables are designed to mount directly to the Under-the-Dash Foot Operated Emergency Brake and Under-the-Dash Hand Operated Emergency Brake and connect up with Lokar Universal Brake Cables. Cables are "U-Cut-to-Fit" and are 6 feet in length. Available in black or stainless housing.

Part No.	Description
EC-8001U	Connector Cable for Lokar Foot Operated and Hand Operated Emergency Brakes - Black Housing
EC-8001HT	Connector Cable for Lokar Foot Operated and Hand Operated Emergency Brakes - Stainless Housing



### TECH NOTE

EC-8001U and EC-8001HT are for use with all styles of Lokar Under-the-Dash Hand and Foot Operated Emergency Brakes.



### INSTALL TIP

Cable can be routed inside the vehicle such as through the console, to keep cable out of sight for a cleaner undercarriage.

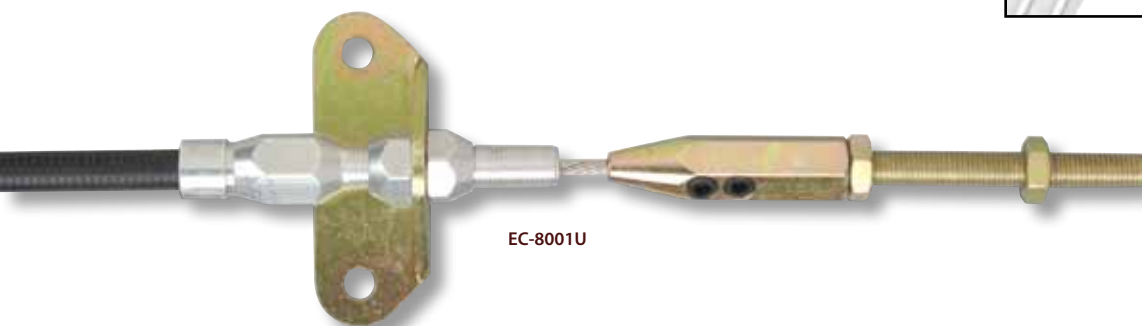
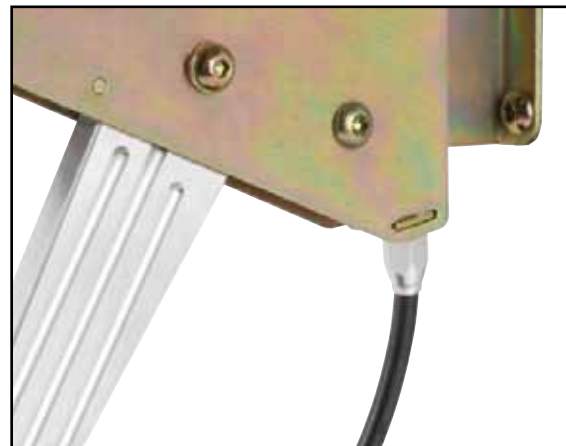

EC-8001U



EC-8001HT

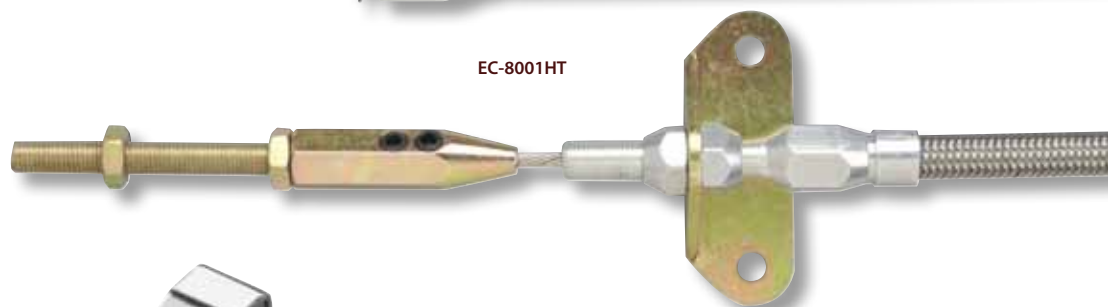

Corvette Clevis



Ford Explorer Clevis



Wilwood Clevis

## Rear Brake Clevis Kits

Lokar Clevis Kits adapt Lokar Emergency Brake Cable Kits for 1984 - 1987 Corvette, 1988 and later Corvette, Jag rear with Wilwood, Wilwood Disc, Wilwood Ford Explorer style with internal hub rears, and Baer brakes.

Part No.	Description
EC-80WC	Wilwood Clevis Kit (Wilwood stand alone, Jag with Wilwood and 1988 & later Corvette)
EC-80CC	Corvette Clevis Kit (1984 to 1987 Corvette and Baer Brakes)
EC-81FC	Wilwood/Ford Explorer Style Rear Clevis Kit



## Connector Cables for Original Factory Under-the-Dash Hand Brakes

Lokar Connector Cables work in conjunction with Lokar's Universal Emergency Brake Cables and with stock under-the-dash hand brakes. Kit includes a single 6 foot outer housing designed with a specially extruded liner that "U-Cut-to-Fit" with a 7 foot stainless steel inner cable which resists moisture. Kit comes equipped with quality aluminum fittings and adjuster. Ferrule is included to eliminate fraying of stainless housing.

Yr./Make Hand Brake	Part No.	Description
'37 to '48 Ford	EC-8000U	Black Connector Cable
'37 to '48 Ford	EC-8000HT	Stainless Connector Cable
'38 to '48 Plym/Dodge	EC-8002U	Black Connector Cable
'38 to '48 Plym/Dodge	EC-8002HT	Stainless Connector Cable
'39 to '48 Chevy	EC-8003U	Black Connector Cable
'39 to '48 Chevy	EC-8003HT	Stainless Connector Cable



### TECH NOTE

Use EC-80FU or EC-80FHT Universal Brake Cable Kits with all Lokar Connector Cables. EC-8000U and EC-8000HT fit '37 to '48 Ford passenger cars and '37 to '56 Ford truck hand brakes.

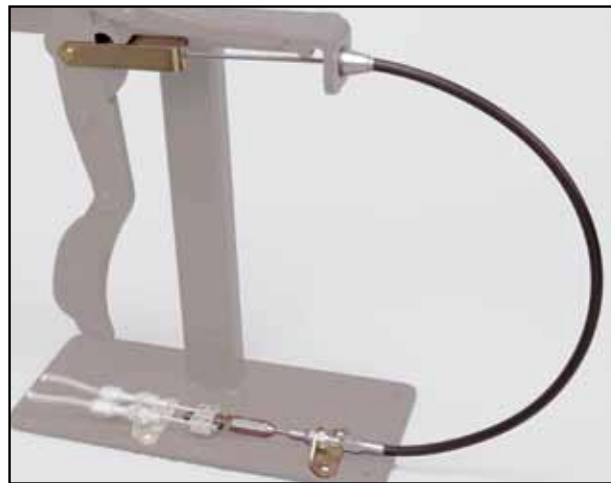

1937 to 1948 Ford passenger cars and 1937 to 1956 Ford Trucks



1939-1948 Chevy



1938 to 1948 Plymouth and Dodge

## U-Cut-to-Fit Rear Brake Cable Kit for 1942 to 1954 Chevy Trucks

Brake Cable Kits for 1942 to 1954 Chevy Trucks. Cables mount from backing plates on rear end to original cross shaft on chassis. Designed with specially extruded liner for extended life of the cable. Stainless inner cable resists moisture. Kit includes two 4 foot outer housings that "U-Cut-to-Fit" and are available in stainless housing or black housing. Design allows rear end backing plate fittings to be removed without removing brake cables. Lokar cables also feature two adjustable cable locks and clevis. Application fits 8" and 9" Ford, Chevy, Chrysler, and Lincoln Versailles drum and disc brakes. Also fits 1987 and earlier Corvette rears. For 1988 or later Corvette and Wilwood disc brakes (with separate e-brake caliper), cables require a Wilwood Clevis Kit (sold separately).

Part No.	Description
EC-8004U	'42 to '54 Chevy Truck Brake Cable Kit – Black Housing
EC-8004HT	'42 to '54 Chevy Truck Brake Cable Kit – Stainless Housing



Under-the-Dash Hand Brake Connector Cable



EC-8004U Black Housing

## Hi-Tech Throttle Cables

All Lokar Hi-Tech Throttle Cables are available in either stainless steel braided housing, black stainless steel braided housing or black housing. They are designed with a specially extruded liner for extended life of the cable – not to be confused with ordinary braided brake hose. Cables are equipped with aluminum fittings and aluminum ferrules to eliminate fraying. “U-Cut-to-Fit” outer housing is available in 24" or 36" lengths with a “U-Cut-to-Fit” stainless inner wire. Clevis is designed without cotter pins or set screws. Adapts to factory and aftermarket pedals. Custom lengths available upon request. Cables mount nicely with Lokar’s array of Brackets and Return Springs (sold separately). Kits complete with installation instructions.

Description	Stainless Steel Housing	BLACK SS Housing	Black Housing
24" Hi-Tech Throttle Cable	TC-1000HT	XTC-1000HT	TC-1000U
36" Hi-Tech Throttle Cable	TC-1000HT36	XTC-1000HT36	TC-1000U36
Tuned-Port '85-'91 & LT1/LT4 Hi-Tech Throttle Cable	TC-1000TP	XTC-1000TP	TC-1000TPU
Blower Drive Hi-Tech Throttle Cable	TC-1000BLD	XTC-1000BLD	TC-1000BLDU
36" LS1 Hi-Tech Throttle Cable (also use for Ram Jet 350)	TC-1000LS1	XTC-1000LS1	TC-1000LS1U
Ford EFI '94 & '95 only* Hi-Tech Throttle Cable	TC-1000EFI	XTC-1000EFI	TC-1000EFIU
36" Vortec Hi-Tech Throttle Cable	TC-1000TPV	XTC-1000TPV	TC-1000TPVU
Ford MOD 4.6, 5.4 V8 Hi-Tech Throttle Cable	TC-1000MOD	XTC-1000MOD	TC-1000MODU
24" Ram Jet 502 Hi-Tech Throttle Cable	TC-1000RJ	XTC-1000RJ	TC-1000RJU
Barry Grant Six Shooter Hi-Tech Throttle Cable	TC-1000BG	XTC-1000BG	TC-1000BGU

Stainless Steel Housing

Black Stainless Steel Housing

Black Housing

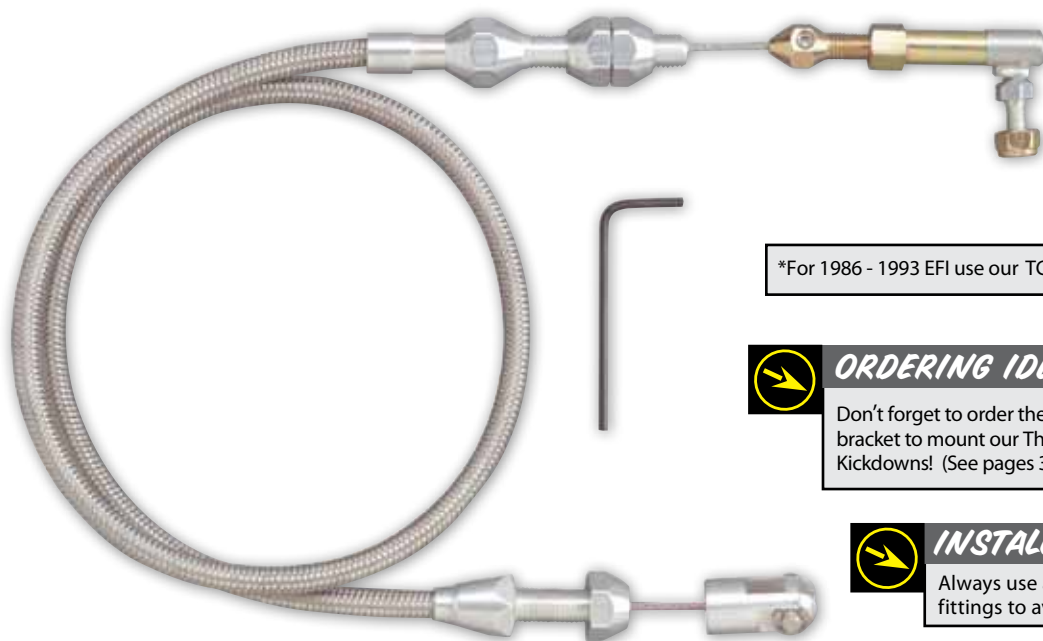

\*For 1986 - 1993 EFI use our TC-1000HT or TC-1000U



### ORDERING IDEA

Don't forget to order the appropriate mounting bracket to mount our Throttle Cables and Hi-Tech Kickdowns! (See pages 39 - 43)



### INSTALL TIP

Always use anti-seize on aluminum fittings to avoid galling.



**Black Stainless Steel Housing**

THROTTLE CABLES AND KICKDOWNS

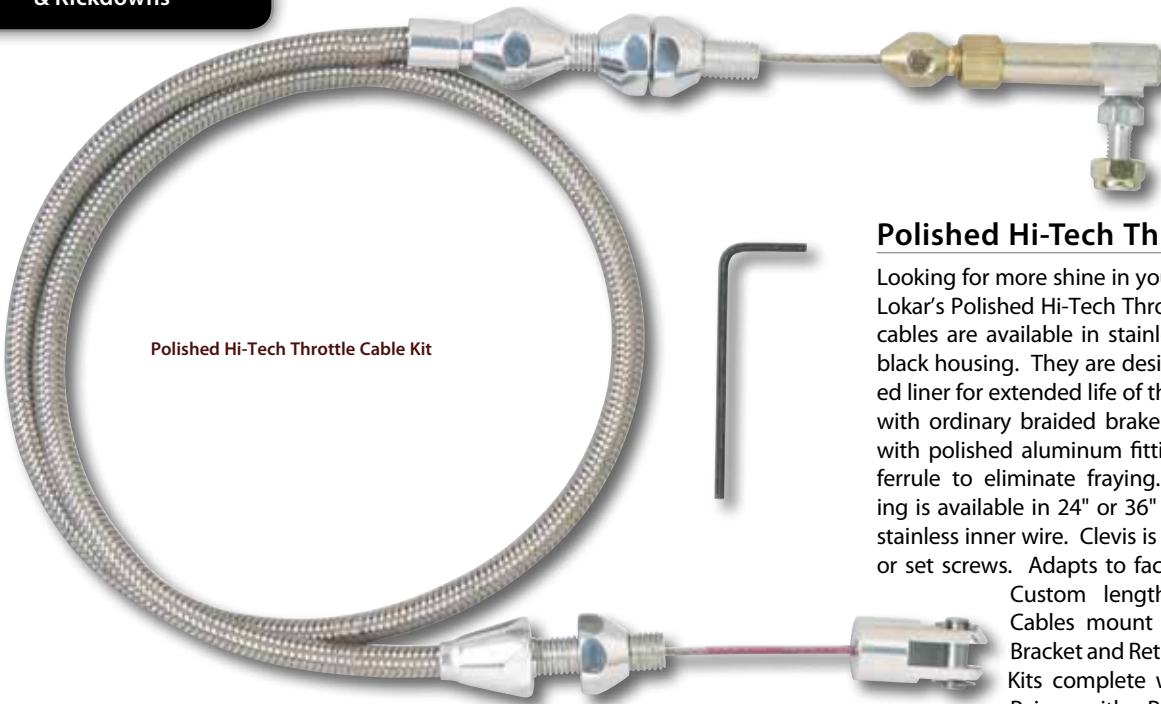

Polished Hi-Tech Throttle Cable Kit

## Polished Hi-Tech Throttle Cables

Looking for more shine in your engine compartment? Try Lokar's Polished Hi-Tech Throttle Cables. Lokar's polished cables are available in stainless steel braided housing or black housing. They are designed with a specially extruded liner for extended life of the cable – not to be confused with ordinary braided brake hose. Cables are equipped with polished aluminum fittings and polished aluminum ferrule to eliminate fraying. "U-Cut-to-Fit" outer housing is available in 24" or 36" lengths with a "U-Cut-to-Fit" stainless inner wire. Clevis is designed without cotter pins or set screws. Adapts to factory and aftermarket pedals.

Custom lengths available upon request. Cables mount nicely with Lokar's array of Bracket and Return Springs (**sold separately**). Kits complete with installation instructions. Pair up with a Polished Kickdown (Page 36).



Polished Black Throttle Cable Kit

### Description

24" Hi-Tech Throttle Cable  
 36" Hi-Tech Throttle Cable  
 Tuned-Port '85-'91 & LT1/LT4 Hi-Tech Throttle Cable  
 24" Blower Drive Hi-Tech Throttle Cable  
 36" Blower Drive Hi-Tech Throttle Cable  
 36" LS1 Hi-Tech Throttle Cable (also use for Ram Jet 350)  
 Ford EFI '94 & '95 only\* Hi-Tech Throttle Cable  
 36" Vortec Hi-Tech Throttle Cable  
 Ford MOD 4.6, 5.4 V8 Hi-Tech Throttle Cable  
 24" Ram Jet 502 Hi-Tech Throttle Cable  
 Barry Grant Six Shooter Hi-Tech Throttle Cable

### Stainless

#### Steel Housing

TCP-1000HT  
 TCP-1000HT36  
 TCP-1000TP  
 TCP-1000BLD  
 TCP-1000BLD36  
 TCP-1000LS1  
 TCP-1000EFI  
 TCP-1000TPV  
 TCP-1000MOD  
 TCP-1000RJ  
 TCP-1000BG

#### Black Housing

TCP-1000U  
 TCP-1000U36  
 TCP-1000TPU  
 TCP-1000BLDU  
 TCP-1000BLDU36  
 TCP-1000LS1U  
 TCP-1000EFIU  
 TCP-1000TPVU  
 TCP-1000MODU  
 TCP-1000RJU  
 TCP-1000BGU

## Duo-Pak Kits

**SAVE** with Lokar's Duo-Pak Hi-Tech Throttle Cable Kits. The kit is equipped with a Throttle Cable in stainless or black housing **PLUS** our Stainless Steel Carburetor Bracket and Return Spring Kit. Duo-Pak only available for carbureted applications with Holley, Edelbrock, AFB, Quadrajet and In-Line Dual Quad carbs.



Duo-Pak Hi-Tech

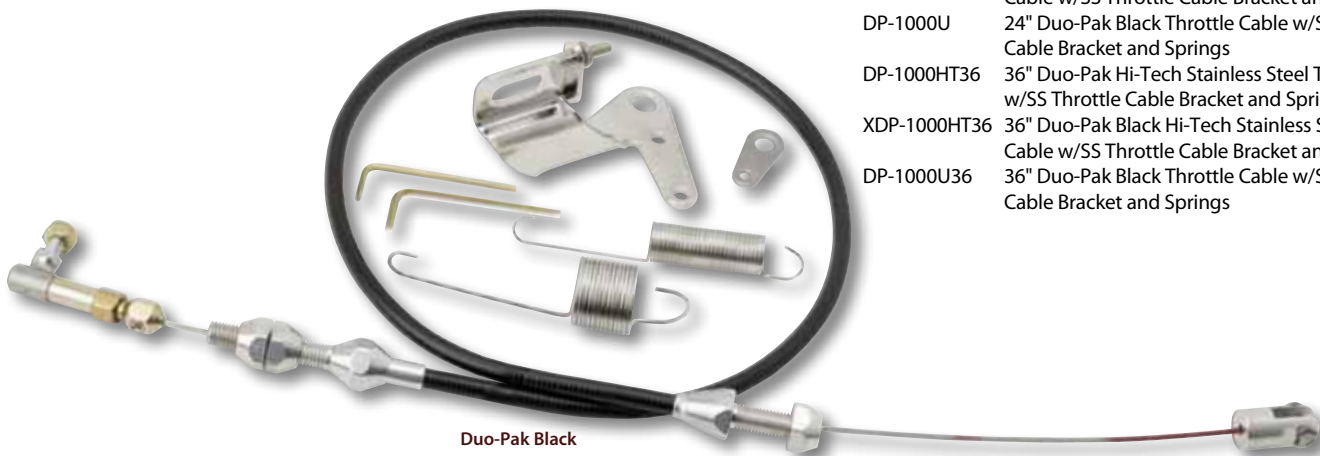

Duo-Pak Black

### Part No.

### Description

DP-1000HT 24" Duo-Pak Hi-Tech Stainless Steel Throttle Cable w/SS Throttle Cable Bracket and Springs  
 XDP-1000HT 24" Duo-Pak Black Hi-Tech Stainless Steel Throttle Cable w/SS Throttle Cable Bracket and Springs  
 DP-1000U 24" Duo-Pak Black Throttle Cable w/SS Throttle Cable Bracket and Springs  
 DP-1000HT36 36" Duo-Pak Hi-Tech Stainless Steel Throttle Cable w/SS Throttle Cable Bracket and Springs  
 XDP-1000HT36 36" Duo-Pak Black Hi-Tech Stainless Steel Throttle Cable w/SS Throttle Cable Bracket and Springs  
 DP-1000U36 36" Duo-Pak Black Throttle Cable w/SS Throttle Cable Bracket and Springs



### Hi-Tech Blower Drive Throttle Cables and Kickdowns

Blower Drive Cables are designed to operate with BDS linkage, Enderle linkage and Weiland linkage for side mounted carburetors. Throttle cables designed with a specially extruded liner for extended life of the cable – not to be confused with ordinary braided brake hose. Cables are equipped with aluminum fittings and aluminum ferrule to eliminate fraying. “U-Cut-to-Fit” outer housing is available in 24" or 36" lengths with a “U-Cut-to-Fit” stainless inner wire. Blower Throttle Cable comes complete with stainless mounting bracket and rod end. Kickdowns are designed with the same quality as our carbureted applications and are available for all transmission applications.

Description	Stainless Steel Housing	BLACK SS Housing	Black Housing
24" Blower Drive Throttle Cable	TC-1000BLD	XTC-1000BLD	TC-1000BLDU
36" Blower Drive Throttle Cable	TC-1000BLD36	XTC-1000BLD36	TC-1000BLDU36
Blower Drive Hi-Tech TH350 Stainless Steel Kickdown	KD-2350BLD	XKD-2350BLD	KD-2350BLDU

Additional transmission applications available upon request.



#### TECH TIP

Ford EFI Throttle Bracket and Kickdown available. (See page 41)

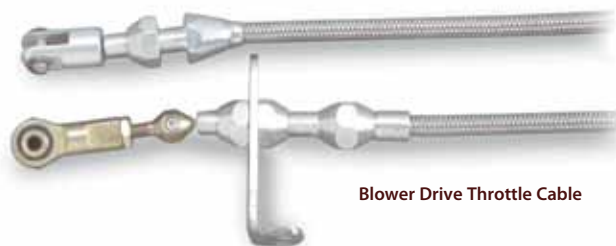

Blower Drive Throttle Cable



GM TH350 Kickdown Blower Drive



## HI-TECH KICKDOWN KITS

Lokar's "U-Cut-to-Fit" Hi-Tech Kickdown Cables are available in either stainless steel braided housing, black stainless steel braided housing or black housing. They are designed with a specially extruded liner for extended life of the cable – not to be confused with ordinary brake hose. Kickdown features aluminum fittings with ferrule to eliminate frayed cable ends. Kickdowns are adaptable for all types of manifolds including tunnel ram, blower manifolds and Weber induction systems. Mount our kickdown with our Stainless Steel Carburetor Bracket and Return Springs (sold separately). Complete instructions included in kit.

Transmission	Stainless Steel Housing	BLACK SS Housing	Black Housing
GM TH350	KD-2350HT	XKD-2350HT	KD-2350HTBlack
GM TH350 Tuned-Port	KD-2350TP	XKD-2350TP	KD-2350TPU
GM TH350 Blower Drive	KD-2350BLD	XKD-2350BLD	KD-2350BLDU
GM Powerglide	KD-20PGHT	XKD-20PGHT	KD-20PGU
GM 700-R4	KD-2700HT	XKD-2700HT	KD-2700U
GM 700-R4 Tuned-Port	KD-2700TP	XKD-2700TP	KD-2700TPU
GM TH200 (1976-1978)	KD-2200HT	XKD-2200HT	KD-2200U
GM 200-4R (1979-1989)	KD-2200RHT	XKD-2200RHT	KD-2200RU
GM 4L60	KD-24L60HT	XKD-24L60HT	KD-24L60U
GM 4L60 Tuned-Port	KD-24L60TP	XKD-24L60TP	KD-24L60TPU
Ford C4	KD-20C4HT	XKD-20C4HT	KD-20C4U
Ford C4 Tuned-Port	KD-20C4TP	XKD-20C4TP	KD-20C4TPU
Ford C6	KD-20C6HT	XKD-20C6HT	KD-20C6U
Ford FMX	KD-2FMXHT	XKD-2FMXHT	KD-2FMXU
Ford AOD	KD-2AODHT	XKD-2AODHT	KD-2AODU
Chrysler 727	KD-2727HT	XKD-2727HT	KD-2727U
Chrysler 904	KD-2904HT	XKD-2904HT	KD-2904U
Chrysler 518	KD-2518HT	XKD-2518HT	KD-2518U



Hi-Tech TH350 Kickdown Kit

Black TH350 Kickdown Kit

Black Stainless Steel TH350 Kickdown Kit



### INSTALL TIP

Always use anti-seize on aluminum fittings to avoid galling.

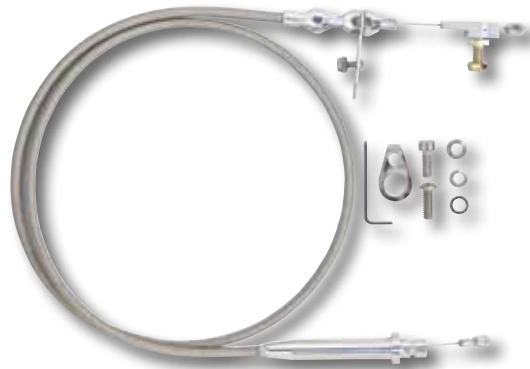

Polished Hi-Tech TH350 Kickdown Kit



Polished Hi-Tech Black TH350 Kickdown Kit

## Polished Hi-Tech Kickdown Kits

To add more shine to your engine compartment, try Lokar's "U-Cut-to-Fit" Polished Kickdown Cables which are available in either stainless steel braided housing or black housing. Cables are designed with a specially extruded liner for extended life of the cable – not to be confused with ordinary brake hose. Kickdown features polished aluminum fittings with polished ferrule to eliminate frayed cable ends. Kickdowns are adaptable for all types of manifolds including tunnel ram, blower manifolds and Weber induction systems. Mount our kickdown with our Stainless Steel Carburetor Bracket and Return Springs (sold separately). Complete instructions included in kit. Pair up with Polished Throttle Cable (Page 34).

Transmission	Stainless Steel Housing	Black Housing
GM TH350	KDP-2350HT	KDP-2350HTBlack
GM TH350 Tuned-Port	KDP-2350TP	KDP-2350TPU
GM TH350 Blower Drive	KDP-2350BLD	KDP-2350BLDU
GM Powerglide	KDP-20PGHT	KDP-20PGU
GM 700-R4	KDP-2700HT	KDP-2700U
GM 700-R4 Tuned-Port	KDP-2700TP	KDP-2700TPU
GM TH200	KDP-2200HT	KDP-2200U
GM 200-4R	KDP-2200RHT	KDP-2200RU
GM 4L60	KDP-24L60HT	KDP-24L60U
GM 4L60 Tuned-Port	KDP-24L60TP	KDP-24L60TPU
Ford C4	KDP-20C4HT	KDP-20C4U
Ford C4 Tuned-Port	KDP-20C4TP	KDP-20C4TPU
Ford C6	KDP-20C6HT	KDP-20C6U
Ford FMX	KDP-2FMXHT	KDP-2FMXU
Ford AOD	KDP-2AODHT	KDP-2AODU
Chrysler 727	KDP-2727HT	KDP-2727U
Chrysler 904	KDP-2904HT	KDP-2904U
Chrysler 518	KDP-2518HT	KDP-2518U

**THROTTLE BODY & CARB END FITTINGS**

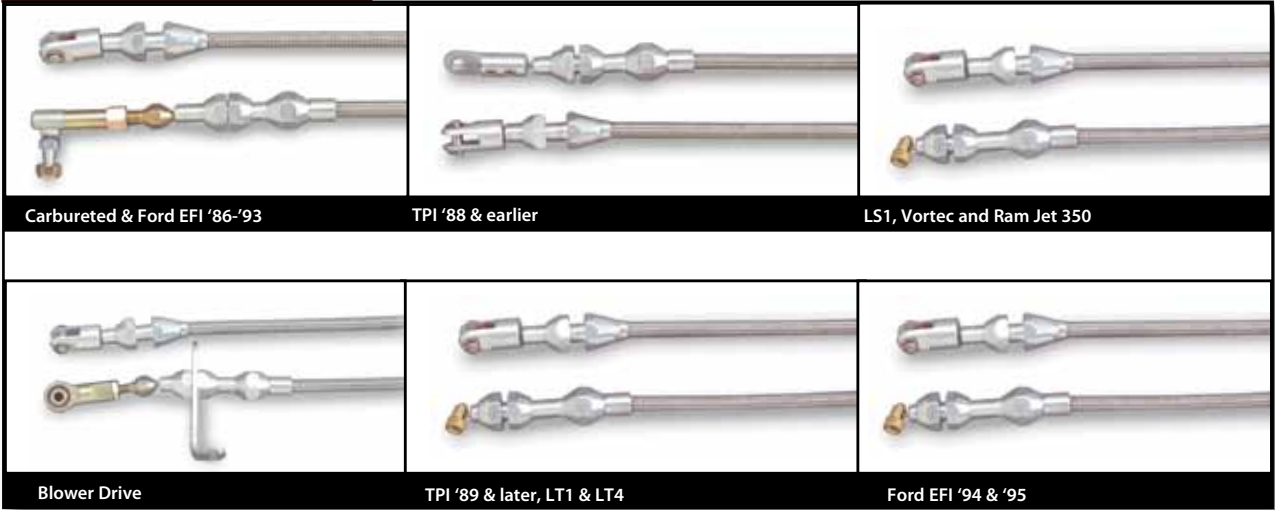

**LOKAR KICKDOWN END FITTINGS**

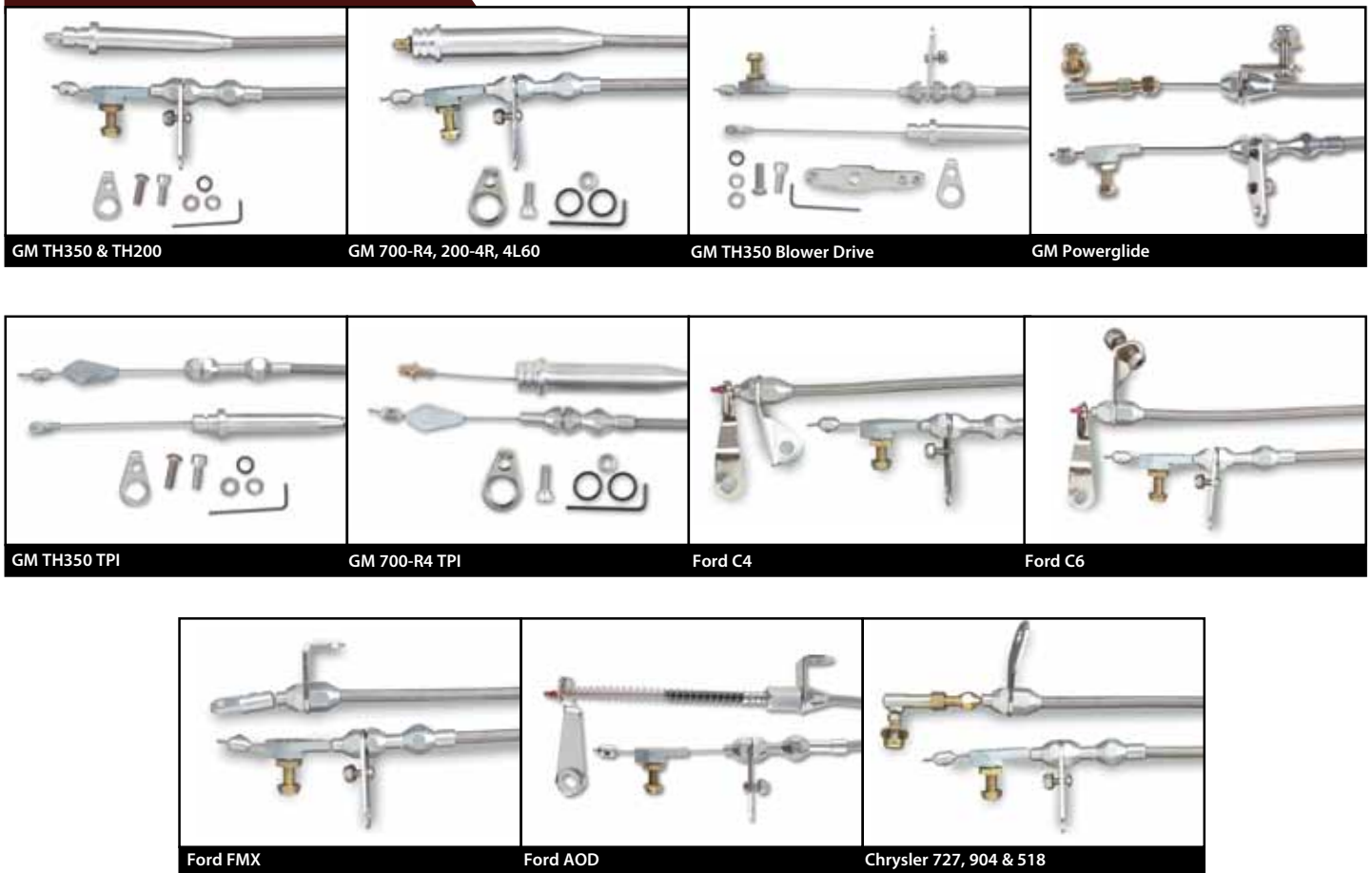

All Ford AOD Shifters require the use of a Lokar Kickdown Kit.



**Black Stainless Steel Housing**

Black Stainless Steel TH400 Electric Kickdown Kit



Hi-Tech TH400 Electric Kickdown Kit



Black TH400 Electric Kickdown Kit



### Hi-Tech TH400 Electric Kickdown Kit

Lokar's Hi-Tech TH400 Electric Kickdown is cable-operated. The electric switch is housed in a billet aluminum box that mounts with transmission pan bolts.\* Kit includes "U-Cut-to-Fit" outer housing in stainless steel, black stainless steel or black. Designed with a specially extruded liner for extended life of the cable, aluminum fittings and stainless steel inner wire and stainless mounting bracket. Mount the kickdown with our Stainless Steel Carburetor Bracket and Return Springs (sold separately). This design eliminates mounting unsightly electrical switches on carburetor, manifold, or near throttle pedal. Complete installation instructions included in kit.

\*Can be mounted in a variety of locations within 48" of carburetor.

**ORDERING TIP**  
 Don't forget to order one of our many brackets to mount our Throttle Cables and Hi-Tech Kickdowns! (See pages 39-43)

Part No.	Description
KD-2400HT	Hi-Tech TH400 Electric Kickdown
KD-2400U	Black TH400 Electric Kickdown
XKD-2400HT	Black Hi-Tech GM TH400 Electric Kickdown
KDP-2400HT	Polished Hi-Tech TH400 Electric Kickdown
KDP-2400U	Polished Black TH400 Electric Kickdown

### TH350 Stainless Kickdown Bracket & Cable

Standard adjustable GM detent (black housing) with Lokar's stainless mounting bracket mounts onto the back two manifold bolts. Designed for 4 barrel-type carburetors for small block Chevys. Kit includes extender for more versatility in adjusting cable length where needed. Stainless bracket also sold separately. Note: Cable housing cannot be cut to fit.

Part No.	Description
KD-2350U	TH350 Stainless Kickdown Bracket & Cable
KDB-4350	TH350 Stainless Kickdown Bracket Only
XKDB-4350	Black TH350 Stainless Kickdown Bracket Only

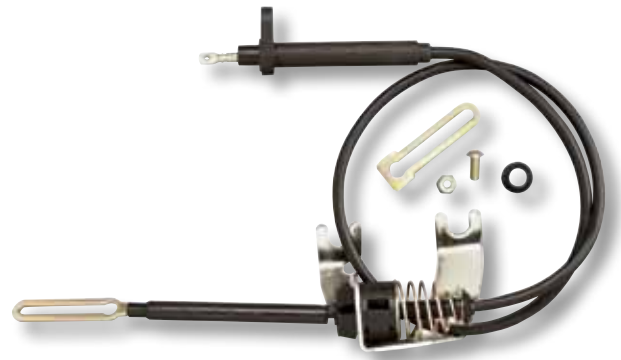

GM detent cannot be cut to fit



Brackets available separately





# THROTTLE CABLE BRACKET AND SPRING KITS

## Stainless Steel Carburetor Bracket & Return Springs

Stainless bracket mounts to rear of Holley, Edelbrock, AFB, Quadrajets, Demon (excludes Street Demon), and In-Line Dual Quads. Stainless bracket and GM designed dual stainless springs are used to mount Lokar's Throttle Cable and Kickdown kits. Design provides improved clearance on Edelbrock carbs. Design includes tension screw to prevent bracket from movement under extreme pressure on a kickdown cable, such as with a 700-R4 transmission.

Part No.	Description
SRK-4000	Stainless Steel Carburetor Bracket and Stainless Springs
XSRK-4000	Black SS Carb Bracket & Black Stainless Springs
SRK-4001	Stainless Steel Carburetor Bracket
XSRK-4001	Black Stainless Steel Carburetor Bracket
SRK-4002	Stainless Steel Springs
XSRK-4002	Black Stainless Steel Springs



## Tuned-Port Brackets

The billet aluminum bracket mounts to the side of the Tuned-Port plenum. The billet aluminum bracket is available with a single stud for throttle only; double stud for throttle and kickdown, and triple stud for a throttle, kickdown and cruise control cable.

Part No.	Description
TCB-40TP1	Tuned-Port Billet Aluminum Bracket w/Single Stud
TCB-40TP2	Tuned-Port Billet Aluminum Bracket w/Double Stud
TCB-40TP3	Tuned-Port Billet Aluminum Bracket w/Triple Stud
XTCB-40TP1	Black Tuned-Port Billet Aluminum Bracket With Single Stud
XTCB-40TP2	Black Tuned-Port Billet Aluminum Bracket With Double Stud
XTCB-40TP3	Black Tuned-Port Billet Aluminum Bracket With Triple Stud
TCB-40TP1P	Polished Tuned-Port Billet Aluminum Bracket Single Stud
TCB-40TP2P	Polished Tuned-Port Billet Aluminum Bracket Double Stud
TCB-40TP3P	Polished Tuned-Port Billet Aluminum Bracket Triple Stud



Available with Single, Double or Triple Stud



'88 and earlier throttle body end fitting shown



LT1 & LT4 Bracket with Throttle, Kickdown & Cruise

## LT1 and LT4 Bracket Kits

Lokar's answer to LT1 cable problems. Stainless Throttle and Kickdown Brackets replace factory brackets. Kit includes stainless arm to mount on LT1 throttle body to operate kickdown. Designed to be used with Lokar's Tuned-Port Throttle Cables and Tuned-Port Kickdowns.

Part No.	Description
TCB-40LT1	1992-1993 LT1 Throttle Cable and Kickdown Cable Brackets
TCB-40LT4	1994 & Later LT1 & LT4 Throttle Cable & Kickdown Cable Brackets
TCB-40LTC	1992 & Later LT1 Cruise Control Bracket Kit
XTCB-40LT1	Black Stainless Steel 1992-1993 LT-1 Throttle Cable & Kickdown Cable Bracket
XTCB-40LT4	Black Stainless Steel 1994 & Later LT1 & LT4 Throttle Cable & Kickdown Cable Bracket



TCB-40LTC



TCB-40LT1



XTCB-40LT4

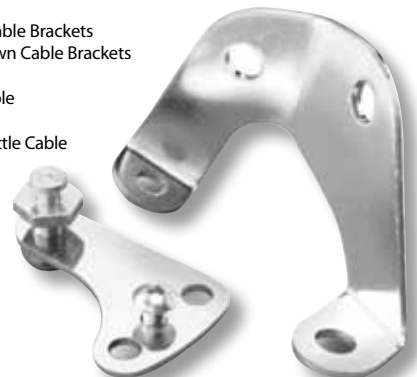

TCB-40LT4

MOUNTING BRACKETS



LS1 Double Stud  
Bracket



LS1 Single Stud  
Bracket

## LS1 Bracket

The billet aluminum bracket mounts to the side of the LS1 manifold and is available with a single stud for throttle only or a double stud to add a cruise control cable.

### Part No. Description

TCB-40LS1	LS1 Throttle Cable Bracket (Single Stud) (1998-1999 GM Throttle Body with 3" linkage cam)
TCB-40LS12	LS1 Throttle Cable and Cruise Control Cable Bracket (Double Stud) (1998-1999 GM Throttle Body with 3" linkage cam)
TCB-40LS13	LS1 Throttle Cable Bracket (Single Stud) (2000-2002 GM and 2004 GTO Throttle Body with 3-1/2" linkage cams)
TCB-40LS14	LS1 Throttle Cable and Cruise Control Cable Bracket (Double Stud) (2000-2002 GM and 2004 GTO Throttle Body with 3-1/2" linkage cams)
XTCB-40LS1	Black LS1 Throttle Cable Bracket 1998- 1999 GM Throttle Body 3" Linkage Cam (Single Stud)
XTCB-40LS12	Black LS1 Throttle Cable & Cruise Control Bracket 1998-1999 GM Throttle Body 3" Linkage Cam (Double Stud)
XTCB-40LS13	Black LS1 Throttle Cable Bracket 2000-2002 GM & 2004 GTO Throttle Body 3-1/2" Linkage Cam (Single Stud)
XTCB-40LS14	Black LS1 Throttle Cable & Cruise Control Bracket 2000-2002 GM & 2004 GTO Throttle Body 3-1/2" Linkage Cam (Double Stud)



LS1 Throttle Cable Bracket - Single Stud Shown

## Ram Jet Brackets

Brackets fit the GM Ram Jet engine. These brackets along with Lokar Throttle Cables will allow the Ram Jet to work properly in any vehicle. When used with an automatic transmission, be sure to use the transmission specific Lokar Kickdown Cable.

### Part No. Description

TCB-40RJ	Stainless Ram Jet Throttle Cable Brackets - Small Block 350
TCB-40RJ1	Stainless Ram Jet Throttle Bracket & Stainless Springs - Big Block 502
XTCB-40RJ	Black Stainless Steel Ram Jet Throttle Cable Bracket - Small Block 350
XTCB-40RJ1	Black Stainless Steel 502 Ram Jet Bracket & Black Stainless Steel Springs



### TECH NOTE

350 Ram Jet uses TC-1000LS1 Throttle Cable  
502 Ram Jet uses TC-1000RJ Throttle Cable



350 Ram Jet Brackets



502 Ram Jet Bracket

350 Ram Jet Brackets



Use LS1 Throttle Cable with 350 Ram Jet Bracket

## Throttle/Kickdown Cable Bracket for Edelbrock Pro Flo XT

The Lokar Throttle/Kickdown Cable Bracket for Edelbrock Pro Flo XT features durable Stainless Steel construction. The bracket allows for easy installation of the Lokar LS1 Throttle Cable and Kickdown kit.

### Part No. Description

TCB-40EDXT	Edelbrock Pro Flo XT Throttle Cable Bracket Kit
XTCB-40EDXT	Black Edelbrock Pro Flo XT Throttle Cable Bracket Kit





EFI Bracket



EFI Bracket

## EFI Bracket

Ford EFI Bracket fits 1986 to 1993 Ford 302 and 351 electronic fuel injection systems that have installed the Mustang EGR spacer. This Stainless Bracket mounts in stock location for easy installation of our Kickdown Cables and Throttle Cables. (1986 to 1993 uses TC-1000HT)

**The EFI Bracket does not fit B.A.P. throttle bodies.**

### Part No. Description

TCB-40EFI	Stainless Steel EFI Throttle Cable Bracket '86-'93 with Mustang EGR Spacer
XTCB-40EFI	Black Stainless Steel Ford EFI Throttle Cable Bracket '86-'93 with Mustang EGR Spacer

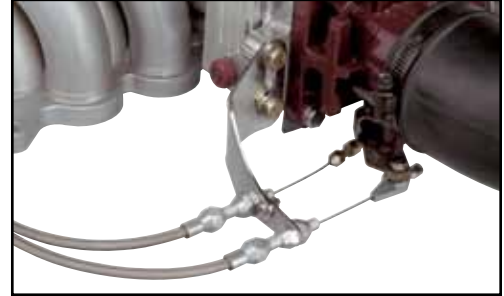

EFI Bracket, Throttle Cable and Kickdown



## Tri-Power Bracket & Spring Kit

Designed for Rochester Tri-Power. Kit includes Stainless Steel Throttle Cable Bracket and Stainless Steel Springs. Stainless bracket mounts under rear carburetor on Rochester 3-2 set-up. Cables operate from center carburetor. Stainless Bracket and Dual Stainless Springs are used to mount Lokar's Throttle Cable and Kickdown assemblies.

### Part No. Description

TRP-4003	Stainless Steel Tri-Power Throttle Cable Bracket and Stainless Springs
TRP-4004	Stainless Steel Tri-Power Bracket only
TRP-4005	Stainless Steel Pontiac Tri-Power Throttle Cable Bracket & Stainless Springs
XTRP-4003	Black Stainless Steel Tri-Power Throttle Cable Bracket & Black Stainless Springs
XTRP-4004	Black Stainless Steel Tri-Power Bracket only
XTRP-4005	Black Stainless Steel Pontiac Tri-Power Bracket and Springs



## Throttle/Kickdown Cable Mounting Bracket for Stromberg® Style Carburetors

- Stainless steel construction
- Allows easy mounting of Lokar Throttle and Kickdown Cables
- Dual stainless steel return springs
- Fits Stromberg 97®, Speedway "9 Super 7", Ford/Holley 94 and Edelbrock 94 carburetors with the 3 bolt base

### Part No. Description

TRP-4006	Stainless Steel 3 Bolt Stromberg® Style Carburetors Tri-Power Throttle Cable Bracket & Springs
TRP-4007	Stainless Steel 3 Bolt Stromberg® Style Carburetors Tri-Power Throttle Bracket
XTRP-4006	Black Stainless Steel 3 Bolt Stromberg® Style Carburetors Tri-Power Throttle Cable Bracket & Springs
XTRP-4007	Black Stainless Steel 3 Bolt Stromberg® Style Carburetors Tri-Power Throttle Bracket



**Now Available for  
Street Applications!**



### Throttle Cable Mounting Bracket & Spring Return Kit for 4150 Series Carburetors

Intended for street applications, the kit includes throttle cable and transmission kickdown cable provisions. Works with Lokar throttle and kickdown cables. Includes stainless steel return springs with dual wound ends for safety and also has adjustable spring tension. Fits most drop base air cleaners. Works with single or dual plane intake manifolds.

**Part No. Description**

TCB-4150	Billet Aluminum Throttle Plate with Kickdown & Spring Return Kit Brushed
XTCB-4150	Black Billet Aluminum Throttle Plate with Kickdown & Spring Return Kit

### Billet Aluminum Throttle/Kickdown Bracket & Spacer Kit for Edelbrock Pro-Flo® Fuel Injection

**Features**

- CNC machined from 6061-T6 billet aluminum for strength and style
- Dual Stainless Steel Return Springs
- Easy installation of Lokar Throttle Cable and Kickdown kits
- All hardware and detailed mounting instructions included
- Recommended by Edelbrock
- For Small Block Chevy

**Part No. Description**

TCB-40ED	Edelbrock Pro-Flo® Injection Spacer Only
TCB-40EDK	Edelbrock Pro-Flo® Injection Spacer/Throttle/Kickdown Bracket and Spring Return Kit
TCB-40EDC	Edelbrock Pro-Flo® Injection Spacer/Throttle/Kickdown/Cruise Bracket and Spring Return Kit
XTCB-40ED	Black Billet Aluminum Edelbrock Pro-Flo® Spacer Only
XTCB-40EDK	Black Billet Aluminum Edelbrock Pro-Flo® Injection Spacer/Throttle/Kickdown Bracket & Black Spring Return Kit
XTCB-40EDC	Black Billet Aluminum Edelbrock Pro-Flo® Injection Spacer/Throttle/Kickdown/Cruise Bracket & Black Spring Return Kit



Cruise Bracket Shown

Throttle/Kickdown Bracket & Spacer Kit for Edelbrock Pro-Flo® Fuel Injection

### Throttle/Kickdown Cable Mounting Bracket for Street Demon™ Carburetors

The Lokar Billet Aluminum Throttle/Kickdown Cable Mounting Bracket for Street Demon™ Carburetors is CNC machined from 6061-T6 billet aluminum. It provides easy installation of Lokar's Throttle and Kickdown Cables. The product features dual stainless steel return springs and comes recommended by Holley.

**Part No. Description**

TCB-40SD	Billet Aluminum Street Demon™ Bracket for Throttle & Kickdown
TCB-40SD1	Billet Aluminum Street Demon™ Bracket for TPS
XTCB-40SD	Black Billet Aluminum Street Demon™ Bracket for Throttle & Kickdown
XTCB-40SD1	Black Billet Aluminum Street Demon™ Bracket for TPS

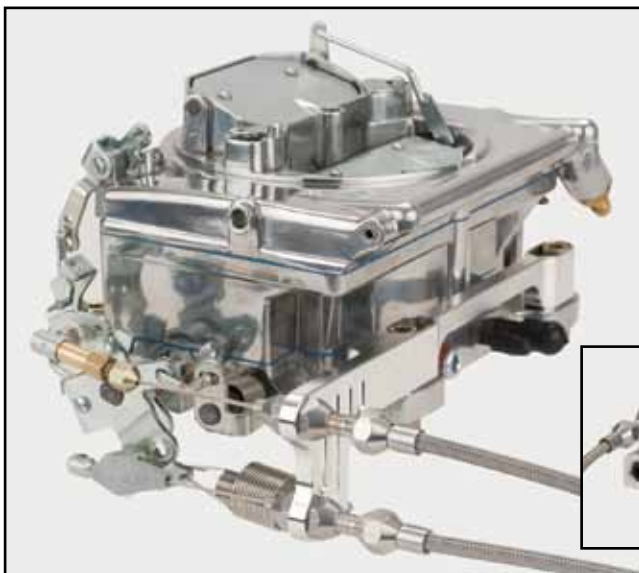

Also available to hold the TPS Sensor

## Billet Aluminum Throttle/Kickdown Cable Mounting Bracket for Edelbrock 4-Barrel Carburetors

### Features

- CNC machined from 6061-T6 billet aluminum for strength and style
- Bracket designed to fit single or dual quad carbs
- Easy installation of Lokar Throttle Cable and Kickdown kits
- Dual Stainless Steel Return Springs
- All hardware and detailed mounting instructions included
- Recommended by Edelbrock
- Attaches to both rear carb bolts to eliminate bracket movement
- Bracket utilizes either bolt pattern offered on Edelbrock carbs & manifolds

### Part No. Description

TCB-40DQ	Billet Aluminum Edelbrock Carb Bracket and Stainless Springs
TCB-40DQ1	Billet Aluminum Edelbrock Carb Bracket & Springs with Progressive Linkage Rod
XTCB-40DQ	Black Billet Aluminum Edelbrock Carburetor Bracket & Springs
XTCB-40DQ1	Black Billet Aluminum Edelbrock Carburetor Bracket & Springs w/Progressive Linkage Rod



Throttle Cable Mounting Bracket for Edelbrock 4-Barrel Carburetors



Billet Aluminum Progressive Linkage System

## Billet Aluminum Progressive Linkage System

### Features

- Progressive Linkage for in-line dual carburetors
- Design allows the use of only one carb during normal driving conditions and both carburetors at wide open throttle
- Available in Midnight Series™

### Part No. Description

TCB-PLR1	Billet Aluminum Progressive Linkage Rod For Edelbrock Carbs Center Distance 6-3/8" - 6-3/4"
TCB-PLR2	Billet Aluminum Progressive Linkage Rod for Edelbrock Carbs Center Distance 8-5/8" - 9"
TCB-PLR3	Billet Aluminum Progressive Linkage Rod for Holley Carbs Center Distance 8-1/4" - 8-5/8"
XTCB-PLR1	Black Billet Aluminum Progressive Linkage Rod For Edelbrock Carburetors Center Distance 6-3/8" - 6-3/4"
XTCB-PLR2	Black Billet Aluminum Progressive Linkage Rod For Edelbrock Carburetors Center Distance 8-5/8" - 9"
XTCB-PLR3	Black Billet Aluminum Progressive Linkage Rod For Holley Carburetors Center Distance 8-1/4" - 8-5/8"

## Billet Aluminum Throttle/Kickdown Bracket Kit for Barry Grant Six Shooter

### Features

- CNC machined from 6061-T6 billet aluminum for strength and style
- Easy installation of Lokar Throttle Cable and Kickdown kits
- Dual Stainless Steel Return Springs
- All hardware and detailed mounting instructions included
- Utilizes existing BG Six Shooter Progressive Linkage

### Part No. Description

TCB-40BG	Billet Aluminum BG Six Shooter Throttle/Kickdown Bracket and Stainless Springs - Fits Small Block Chevy
TCB-BG440	Billet Aluminum BG Six Shooter 440 Mopar Throttle/Kickdown Bracket and Stainless Springs
XTCB-40BG	Black Billet Aluminum Barry Grant Six Shooter Throttle/Kickdown Bracket & Springs - Fits Small Block Chevy
XTCB-BG440	Black Billet Aluminum Barry Grant Six Shooter 440 Mopar Throttle/Kickdown Bracket & Springs

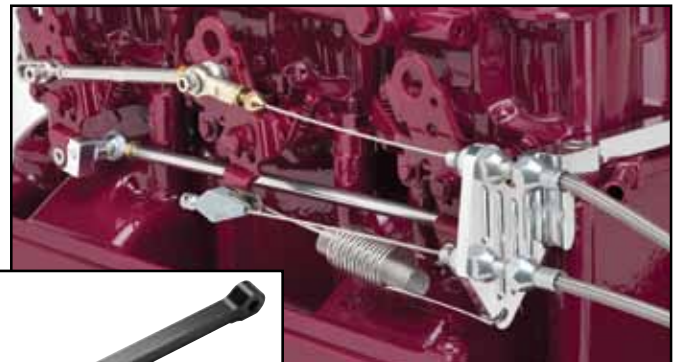

Throttle/Kickdown Bracket Kit for Barry Grant Six Shooter (Small Block Chevy Shown)

## DRIVE-BY-WIRE ELECTRONIC THROTTLE CONTROL PEDAL ASSEMBLY

Lokar has partnered with Williams Controls, the world leader in heavy duty electronic throttle pedals.

### Features

- The first programmable electronic throttle pedal (Drive-By-Wire) for the automotive aftermarket
- Programmable Non-Contact (Solid State) Hall Effect Sensor for most GM, Ford & Mopar applications
- Splined pedal arm for versatile mounting
- All metal construction; Aluminum and Stainless Steel
- 3 times better performance over standard OEM pedals
- Over 90 years of combined throttle pedal experience
- Sensor programmed on pedal to optimize electrical output for quick throttle response (No pedal lag)



DBW-6200  
Direct Fit Throttle Pedal Pad for  
Cadillac CTS-V Drive-By-Wire Pedal  
(Electronic pedal not included)



### TECH NOTE

DBW-6200 is designed to fit  
GM Part # 10379038



XDBW-6200



DBW-6012  
(Pedal set only)

XDBW-6012  
(Pedal set only)



Factory Throttle Body

### Part No. Description

#### Electronic Throttle Control

DBW-FORD01	2011-2012 Ford Mustang/Coyote Drive-By-Wire Electronic Throttle Control With Harness
DBW-GM01	2007 & Up GM Truck/SUV Drive-By-Wire Electronic Throttle Control with Harness
DBW-GM02	2006 & Up Corvette Drive-By-Wire Electronic Throttle Control With Harness

#### Drive-By-Wire Pedal Set

DBW-6001	Drive-By-Wire Billet Aluminum Spring-Loaded Throttle Pedal Ball-Milled
DBW-6004	Drive-By-Wire Billet Aluminum Spring-Loaded Throttle Pedal w/Rubber
DBW-6007	Drive-By-Wire Chromed Steel Spring-Loaded Throttle Pedal w/Rubber
DBW-6010	Drive-By-Wire XL Billet Aluminum Spring-Loaded Throttle Pedal Ball-Milled
DBW-6012	Drive-By-Wire XL Billet Aluminum Spring-Loaded Throttle Pedal w/Rubber
DBW-6016	Drive-By-Wire XL Chromed Steel Spring-Loaded Throttle Pedal w/Rubber
DBW-6070	Drive-By-Wire Chromed Steel Spoon Throttle Pedal
DBW-6103	Drive-By-Wire Mini Oval Billet Spring-Loaded Throttle Pedal w/Rubber
DBW-6104	Drive-By-Wire Oval Billet Spring-Loaded Throttle Pedal w/Rubber
DBW-6105	Drive-By-Wire XL Oval Billet Spring-Loaded Throttle Pedal w/Rubber
DBW-6151	Drive-By-Wire Lakester Steel Throttle Pedal - Chromed
DBW-6154	Drive-By-Wire Lakester Steel Throttle Pedal - RAW
DBW-6200	Direct Fit Throttle Pedal Pad for Cadillac CTS-V Drive-By-Wire Pedal
XDBW-6004	Black Drive-By-Wire Billet Aluminum Spring-Loaded Throttle Pedal w/Rubber
XDBW-6007	Black Drive-By-Wire Steel Spring-Loaded Throttle Pedal w/Rubber
XDBW-6012	Black Drive-By-Wire XL Billet Aluminum Spring-Loaded Throttle Pedal w/Rubber
XDBW-6016	Black Drive-By-Wire XL Steel Spring-Loaded Throttle Pedal w/Rubber
XDBW-6070	Black Drive-By-Wire Steel Spoon Throttle Pedal
XDBW-6103	Black Drive-By-Wire Mini Oval Billet Spring-Loaded Throttle Pedal w/Rubber
XDBW-6104	Black Drive-By-Wire Oval Billet Spring-Loaded Throttle Pedal w/Rubber
XDBW-6105	Black Drive-By-Wire XL Oval Billet Spring-Loaded Throttle Pedal w/Rubber
XDBW-6151	Black Drive-By-Wire Lakester Steel Throttle Pedal - Black
X DBW-6200	Direct Fit Throttle Pedal Pad for Cadillac CTS-V Drive-By-Wire Pedal

## Competitor Series Throttle Assemblies



Lokar's Competitor Series Throttle Assemblies are designed with a unique internal spanner nut ensuring perfect pedal tension. This pedal is in a class of its own; by adding this built in tensioning feature, we have eliminated the possibility of excess 'slop' in the throttle pedal.

Another milestone of the Competitor Series Throttle Pedal is its incredibly sturdy mounting base. The design of this pedal has enabled us to provide over an inch and a quarter wide mounting base yet maintain a narrow and sleek appearance. If that weren't enough, the mounting base is available in either a centered or an offset version which will raise or lower the center of the throttle assembly an entire inch. This feature is incredibly accommodating when installing the pedal in a vehicle which already has the throttle cable installed.

In our everlasting quest for perfection, we have also built the Competitor Series Throttle Assemblies with our exclusive large diameter 3/4" x 48 tooth fine-spline steel insert to provide the ultimate in strength and durability. This also allows for infinitely adjustable arms which can also be swapped for right and left adjustment of the throttle pad.

All of these features coupled with a spring-loaded throttle pad, Delrin® bushings, and superior design have made the Competitor Series Throttle Pedal the finest and most versatile throttle pedal available.



Vertical Offset Mounting

Centered Mounting

BAG-6148

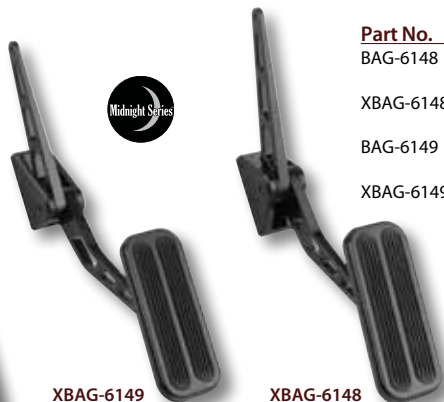

XBAG-6149

XBAG-6148

Part No.	Description
BAG-6148	Billet Aluminum Competitor Throttle Pedal Assembly w/Rubber - Centered Mounting - Brushed
XBAG-6148	Billet Aluminum Competitor Throttle Pedal Assembly w/Rubber - Centered Mounting - Black
BAG-6149	Billet Aluminum Competitor Throttle Pedal Assembly w/Rubber - Vertical Offset Mounting - Brushed
XBAG-6149	Billet Aluminum Competitor Throttle Pedal Assembly w/Rubber - Vertical Offset Mounting - Black

## Lakester Throttle Assemblies & Pedal Pads

Lakester hot rod pedal styling is a continuation of the many nostalgic products we offer at Lokar. The pedals have the same quality you have come to expect from its sister steel spoon throttle pedal and round brake/clutch pad. The removable lower arm is splined for versatility in mounting to the right or left of the mounting bracket. Lakester pedals feature curved pads and arms.

These new nostalgic style pedals are available in chromed, black and raw. This unique pedal design will give your favorite vehicle an all new look. The throttle pedal is designed using Delrin® bushings for smooth operation when throttling up or down during daily use.



Part No.	Description
BAG-6151	Lakester Steel Throttle Pedal - Chromed
XBAG-6151	Lakester Steel Throttle Pedal - Black
BAG-6154	Lakester Steel Throttle Pedal - Raw
BAG-6152	Lakester Steel Brake/Clutch - Chromed (each)
XBAG-6152	Lakester Steel Brake/Clutch - Black (each)
BAG-6155	Lakester Steel Brake/Clutch - Raw (each)
BAG-6153	Lakester Steel Automatic Brake - Chromed
XBAG-6153	Lakester Steel Automatic Brake - Black
BAG-6156	Lakester Steel Automatic Brake - Raw
BAG-6170	Lakester Steel Dimmer Cover - Chromed
XBAG-6170	Lakester Steel Dimmer Cover - Black
BAG-6171	Lakester Steel Dimmer Cover - Raw



RAW

Chromed

Black



FMG-6098 Eliminator Floor Mount Throttle Pedal with Rubber Inserts

## Award Winning

### Eliminator Floor Mount Throttle Pedals

RECIPIENT OF NSRA BEST NEW PRODUCT, Lokar's Eliminator Floor Mount Throttle Pedal is designed with the Signature Lokar Quality you have come to expect. Pedal eliminates routing cables through firewall and comes equipped with a billet aluminum splined adjustable shaft and stainless steel "under-the-floor" cable mounting bracket. Mounts in multiple positions for floor and toe board angles. Designed with built-in pedal travel stops.

Part No.	Description
FMG-6097	Billet Aluminum Eliminator Floor Mount Throttle Pedal - Brushed
FMG-6098	Billet Aluminum Eliminator Floor Mount Throttle Pedal w/Rubber - Brushed
XFMG-6098	Billet Aluminum Eliminator Floor Mount Throttle Pedal w/Rubber - Black
GPS-6016	1/2" Billet Aluminum Floor Mount Throttle Pedal Spacer - Brushed
XGPS-6016	1/2" Billet Aluminum Floor Mount Throttle Pedal Spacer - Black



#### TECH NOTE

Requires 36" "U-Cut-to-Fit" Lokar Throttle Cable for most applications. Order 48" cable for LS1, Ram Jet 350, and Vortec applications.



FMG-6097 Eliminator Floor Mount Throttle Pedal



XFMG-6098 Eliminator Floor Mount Throttle Pedal with Rubber Inserts - Black



Under-the-floor cable mounting bracket



GPS-6016 1/2" Billet Aluminum Floor Mount Throttle Pedal Spacer

## Billet Aluminum Adjustable Foot Rests

### Features

- Match Lokar pedals
- Adjustable angles for foot comfort
- Universal mounting locations
- Available in three styles:
  - Oval pad with rubber inserts - brushed or black
  - Rectangular pad in ball-milled billet aluminum - brushed
  - Rectangular pad with rubber inserts - brushed or black

### Part No. Description

BFR-6114	Oval Billet Aluminum Pad w/Rubber - Brushed
XBFR-6114	Oval Billet Aluminum Pad w/Rubber - Black
BFR-6115	Rectangular Billet Aluminum Pad Ball-milled - Brushed
BFR-6116	Rectangular Billet Aluminum Pad w/Rubber - Brushed
XBFR-6116	Rectangular Billet Aluminum Pad w/Rubber - Black

### Dimensions:

- Oval: 1-3/4" x 3-3/4"
- Rectangular: 1-1/2" x 4"



BFR-6116

BFR-6115

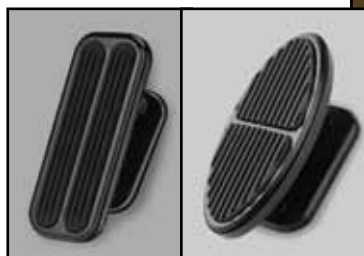

XBFR-6116

XBFR-6114



BFR-6114



# BILLET ALUMINUM THROTTLE ASSEMBLIES AND PEDAL PADS

## Standard Billet Aluminum Throttle Assemblies and Pedal Pads

Ball-milled aluminum throttle pedal has spring-loaded pad like OEM design. Removable lower arm is splined for versatility in mounting to the right or left of the mounting bracket. Lokar's exclusive upper arm is a one-piece design. Shaft and arm are one piece, requiring no pins. Matching brake pad is designed with a 1/2" - 20 thread and includes a 1/2" - 20 stud in kit. Can be mounted centered or off center. Dimmer fits both Chevy and Ford.



BFR-6116 Foot Rest  
(See page 46)

### Part No. Description

BAG-6001	Billet Aluminum Throttle Pedal Ball-Milled – Brushed
BAG-6002	Billet Aluminum Brake Pad Ball-Milled – Brushed
BAG-6003	Billet Aluminum Dimmer Switch Cover Ball-Milled – Brushed
BAG-6004	Billet Aluminum Throttle Pedal w/Rubber – Brushed
XBAG-6004	Billet Aluminum Throttle Pedal w/Rubber – Black
BAG-6005	Billet Aluminum Brake Pad w/Rubber – Brushed
XBAG-6005	Billet Aluminum Brake Pad w/Rubber – Black
BAG-6006	Billet Aluminum Dimmer Switch Cover w/Rubber – Brushed
XBAG-6006	Billet Aluminum Dimmer Switch Cover w/Rubber – Black
GPS-6014	3/4" Billet Aluminum Throttle Pedal Spacer – Brushed
XGPS-6014	3/4" Billet Aluminum Throttle Pedal Spacer – Black



GPS-6014  
3/4" Billet Aluminum  
Throttle Pedal Spacer



BAG-6004

BAG-6005

BAG-6006



XBAG-6006

XBAG-6005

XBAG-6004



XBFR-6116 Foot Rest  
(See page 46)



BFR-6115 Foot Rest  
(See page 46)



BAG-6001

BAG-6002

BAG-6003

## XL Series Billet Aluminum Throttle Assemblies and Pedal Pads

XL Series ball-milled billet aluminum Throttle Pedal is designed just like our standard billet aluminum throttle assemblies, but has an EXTRA LARGE pad for those seeking more comfort and safety. Throttle Pedal pad is spring-loaded like OEM design. Removable lower arm is splined for versatility in mounting to the right or left of the mounting bracket. Lokar's exclusive upper arm is a one-piece design. Shaft and arm are one piece, requiring no pins. Matching XL Series brake pad is designed with a 1/2"-20 thread and includes a 1/2"-20 stud in kit. Can be mounted centered or off center.

**Part No.**      **Description**

- BFG-6010      XL Series Billet Aluminum Throttle Pedal Ball-Milled - Brushed
- BFG-6011      XL Series Billet Aluminum Brake Pad Ball-Milled - Brushed
- BAG-6003      Billet Aluminum Dimmer Switch Cover Ball-Milled -Brushed
- BFG-6012      XL Series Billet Aluminum Throttle Pedal w/Rubber - Brushed
- XBFG-6012      XL Series Billet Aluminum Throttle Pedal w/Rubber - Black
- BFG-6013      XL Series Billet Aluminum Brake Pad w/Rubber - Brushed
- XBFG-6013      XL Series Billet Aluminum Brake Pad w/Rubber - Black
- BAG-6006      Billet Aluminum Dimmer Switch Cover w/Rubber - Brushed
- XBAG-6006      Billet Aluminum Dimmer w/Rubber - Black



**INSTALL TIP**  
Always mount throttle pedals first before installing throttle cable to obtain proper alignment.

"XL"      Standard

"XL"      Standard

**Dimensional Comparison**

	Throttle Pedal	Brake Pad
XL Series Dimensions	2" x 5"	3-3/4" x 2-3/4"
Standard Dimensions	1-1/2" x 4"	3" x 2"



## Oval Billet Aluminum Throttle Assemblies & Pedal Pads

Oval billet aluminum throttle pedals and brake pads come in three convenient sizes – Mini, Standard, and XL. The throttle pedal is spring-loaded with a removable lower arm that is splined for versatility and can be mounted to the right or left of the mounting bracket. The shaft and arm are one piece – requiring no pins. Rubber inserts provide foot traction for safety. Brake pads are designed with a 1/2"-20 thread and include a 1/2"-20 stud in the kit. Can be mounted centered or off center.

**Part No.**      **Description**

- BAG-6103      Mini Oval Billet Aluminum Throttle Pedal - Brushed
- XBAG-6103    Mini Oval Billet Aluminum Throttle Pedal – Black
- BAG-6104      Standard Oval Billet Aluminum Throttle Pedal – Brushed
- XBAG-6104    Standard Oval Billet Aluminum Throttle Pedal – Black
- BAG-6105      XL Oval Billet Aluminum Throttle Pedal – Brushed
- XBAG-6105    XL Oval Billet Aluminum Throttle Pedal – Black
- BAG-6106      Mini Oval Billet Aluminum Brake Pad – Brushed
- XBAG-6106    Mini Oval Billet Aluminum Brake Pad – Black
- BAG-6107      Standard Oval Billet Aluminum Brake Pad – Brushed
- XBAG-6107    Standard Oval Billet Aluminum Brake Pad – Black
- BAG-6108      XL Oval Billet Aluminum Brake Pad – Brushed
- XBAG-6108    XL Oval Billet Aluminum Brake Pad – Black
- BAG-6109      Oval Billet Aluminum Dimmer Cover – Brushed
- XBAG-6109    Oval Billet Aluminum Dimmer Cover – Black



BFR-6114 Foot Rest  
(See page 46)



**Standard**

Oval Throttle Pedal and Brake Pad Dimensional Comparison		
	Throttle Pedal	Brake Pad
Mini Oval	1-3/8" x 2-3/8"	3-7/16" x 1-5/8"
Standard Oval	1-3/4" x 3-3/4"	3-3/4" x 1-3/4"
XL Oval	2-3/8" x 5"	5" x 2-3/8"



BAG-6109



BAG-6107

BAG-6104



**TECH NOTE**

Brake Pad and Dimmer Cover can be mounted vertically or horizontally.



**XL**

BAG-6109

BAG-6108

BAG-6105



**Mini**

BAG-6109

BAG-6106

BAG-6103



**Standard**



XBAG-6109



XBAG-6107



BFR-6114 Foot Rest  
(See Page 46)



XBAG-6104

## Steel Throttle Assemblies and Pedal Pads Standard & XL Series

Lokar's Steel Throttle Pedals are the first spring-loaded steel pedal in the industry and are designed after OEM pedals. Removable lower arm is splined for versatility in mounting to the right or left of the mounting bracket.

Lokar offers these steel assemblies in both our standard pad size and our larger, XL pad. The XL pad is EXTRA LARGE for those seeking more substance under foot. Matching Steel Brake Pads mount with a 1/2"-20 stud built into the back of the pad. Matching Dimmer Switch Cover fits both Chevy and Ford. Available in chromed or black finish.

### Part No. Description

SG-6007	Steel Throttle Pedal w/Rubber – Chromed
XSG-6007	Steel Throttle Pedal w/Rubber – Black
SG-6008	Steel Brake Pad w/Rubber – Chromed
XSG-6008	Steel Brake Pad w/Rubber – Black
SG-6009	Steel Dimmer Switch Cover (Fits Chevy and Ford) - Chromed
XSG-6009	Steel Dimmer Switch Cover (Fits Chevy and Ford) - Black
SG-6016	XL Steel Throttle Pedal w/Rubber – Chromed
XSG-6016	XL Steel Throttle Pedal w/Rubber – Black
SG-6017	XL Steel Brake Pad w/Rubber – Chromed
XSG-6017	XL Steel Brake Pad w/Rubber – Black
GPS-6015	1/2" Throttle Pedal Spacer for Steel Pedals – Brushed
XGPS-6015	1/2" Throttle Pedal Spacer for Steel Pedals – Black

All black pedals are powder coated steel



## Steel Spoon Throttle Assemblies and Pedal Pads

Nostalgic hot rod style is exhibited with Lokar's Spoon Throttle Pedal. The pedal is designed with the same quality as demonstrated in other Lokar Throttle assemblies. The removable lower arm is splined for versatility in mounting to the right or left of the mounting bracket. Steel round brake/clutch pads and dimmers are equipped with rubber inserts which completes the ensemble. The Spoon Pedal and matching Brake/Clutch Pad and Dimmer are available in chromed or black finish.

### Part No. Description

SPO-6070	Steel Spoon Throttle Pedal – Chromed
XSPO-6070	Steel Spoon Throttle Pedal – Black
SPO-6071	Round Steel Brake/Clutch Pad w/Rubber – Chromed
XSPO-6071	Round Steel Brake/Clutch Pad w/Rubber – Black
SPO-6072	Round Steel Dimmer Switch Cover w/Rubber – Chromed
XSPO-6072	Round Steel Dimmer Switch Cover w/Rubber – Black

All black pedals are powder coated steel





BAG-6074 Throttle Pedal Shown and BAG-6076 Brake/Clutch Pad shown



XBAG-6078



XBAG-6074

## 1955 - 1957 Chevy Throttle Assemblies

The Lokar 1955-1957 Chevy billet aluminum Throttle Assembly is designed to convert original rod linkage to Lokar's modern throttle cable system. It is designed to mount in original firewall location with offset bezel washers to align cable through firewall. The arms are splined for fine adjustment and can be switched for right and left adjustment of the throttle pad. The Throttle Pad is spring-loaded like OEM design and measures 2" x 5".

### Part No. Description

- BAG-6073 1955-1957 Chevy Billet Aluminum Throttle Pedal Assembly - Brushed
- BAG-6074 1955-1957 Chevy Billet Aluminum Throttle Pedal Assembly w/Rubber - Brushed
- XBAG-6074 1955-1957 Chevy Billet Aluminum Throttle Pedal Assembly w/Rubber - Black
- BAG-6112 1955-1957 Chevy Billet Aluminum Throttle Pedal Assembly (1" longer upper arm for Big Block) - Brushed
- BAG-6113 1955-1957 Chevy Billet Aluminum Throttle Pedal Assembly w/Rubber (1" longer upper arm for Big Block) - Brushed
- XBAG-6113 1955-1957 Chevy Billet Aluminum Throttle Pedal Assembly w/Rubber (1" longer upper arm for Big Block) - Black



Engine compartment side of '55-'57 throttle pedal shaft



'55-'57 throttle pedal shaft

## 1955 - 1957 Chevy Traditional Flat Brake Pads, Clutch Pads & Power Brake Pads

Brake and Clutch Pads are designed to match the Throttle Pedal assemblies. With Lokar's exclusive mounting design, no drilling is needed to mount pads, which allows easy installation.

### Part No. Description

- BAG-6075 1955-1957 Chevy Billet Aluminum Brake/Clutch Pad - Brushed
- BAG-6076 1955-1957 Chevy Billet Aluminum Brake/Clutch Pad w/Rubber - Brushed
- XBAG-6076 1955-1957 Chevy Billet Aluminum Brake/Clutch Pad w/Rubber - Black
- BAG-6077 1955-1957 Chevy Billet Aluminum Automatic Power Brake Pad - Brushed
- BAG-6078 1955-1957 Chevy Billet Aluminum Automatic Power Brake Pad w/Rubber - Brushed
- XBAG-6078 1955-1957 Chevy Billet Aluminum Automatic Power Brake Pad w/Rubber - Black
- BAG-6079 1955-1957 Chevy XL Billet Aluminum Automatic Non-Power Brake Pad - Brushed
- BAG-6080 1955-1957 Chevy XL Billet Aluminum Automatic Non-Power Brake Pad w/Rubber - Brushed
- XBAG-6080 1955-1957 Chevy XL Billet Aluminum Automatic Non-Power Brake Pad w/Rubber - Black



Power Brake Mount



XL Non-Power Brake Mount



### TECH NOTE

#### Brake and Clutch Pads

(Outside measurement of 3-7/8" x 2-5/8" fits 3-1/4" x 1-5/8" original steel brake pedal)

#### Power Brake Pads

(Outside measurement of 6" x 2-3/4" fits 4-3/4" x 2-3/8" original steel brake pedal)

#### XL Non-Power Brake Pads

(Outside measurement of 6" x 2-3/4" and fits 3-1/4" x 1-5/8" original steel brake pedal)

DIRECT FIT THROTTLE ASSEMBLIES & PEDAL PADS

## 1955 - 1957 Chevy Curved Brake Pads, Clutch Pads & Power Brake Pads

For a compact and clean look, Lokar has put a modern bend on classic brake pedal pads. Our Curved Brake/Clutch Pedal Pads add style and function to your classic car. Designed with hidden screws, these pads are curved and pocketed to match and bolt directly to the factory steel brake pedal. Each brake pedal pad has been fashioned after its corresponding factory rubber pad and is available in brushed or black finish.

**Part No.**      **Description**

BAG-6137	1955-1957 Chevy Billet Aluminum Curved Power Brake Pad w/Rubber - Brushed
XBAG-6137	1955-1957 Chevy Billet Aluminum Curved Power Brake Pad w/Rubber - Black
BAG-6138	1955-1957 Chevy Billet Aluminum Curved XL Non-Power Brake Pad w/Rubber - Brushed
XBAG-6138	1955-1957 Chevy Billet Aluminum Curved XL Non-Power Brake Pad w/Rubber - Black
BAG-6139	1955-1957 Chevy Billet Aluminum Curved Brake/Clutch Pad Manual w/Rubber (Pair) - Brushed
XBAG-6139	1955-1957 Chevy Billet Aluminum Curved Brake/Clutch Pad Manual w/Rubber (Pair) - Black



### ORDERING TIP

For a truly complete look, combine these brake pedal pads with one of our direct fit throttle pedal assemblies



## 1958 - 1965 FULL SIZE CHEVY CURVED BRAKE & CLUTCH PADS

For a compact and clean look, Lokar has put a modern bend on classic brake pedal pads. Our Curved Brake/Clutch Pedal Pads add style and function to your classic car. Designed with hidden screws, these pads are curved to match and bolt directly to the factory steel brake/clutch pedal. Each brake/clutch pedal pad has been fashioned after its corresponding factory rubber pad and is available in brushed or black finish. 1958-1965 Pedal Pads are available for Automatic Brake and Brake/Clutch.



**Part No.**      **Description**

BAG-6140	1958-1965 Chevy Billet Aluminum Curved Manual Brake/Clutch Pad w/Rubber (Pair) - Brushed
XBAG-6140	1958-1965 Chevy Billet Aluminum Curved Manual Brake/Clutch Pad w/Rubber (Pair) - Black
BAG-6141	1958-1965 Chevy Billet Aluminum Curved Automatic Brake w/Rubber - Brushed
XBAG-6141	1958-1965 Chevy Billet Aluminum Curved Automatic Brake w/Rubber - Black

## 1967 - 1969 CAMARO/FIREBIRD THROTTLE PEDAL ASSEMBLIES AND PEDAL PADS

### 1967 - 1969 Camaro/Firebird Throttle Assemblies

Direct replacement Throttle Pedal Assemblies for 1967-1969 Camaro/Firebird with ball-milled or with rubber insert pads eliminate the factory rod linkage, are designed to mount in the original firewall location and utilize a modern Lokar Throttle Cable system. The arms are splined for fine adjustment and can be switched for right and left adjustment of the throttle pad, which is spring-loaded and measures 2" x 5". Available in brushed or black finish.

#### Part No. Description

BAG-6095	1967-1969 Camaro/Firebird Billet Aluminum Throttle Pedal Assembly – Brushed
BAG-6096	1967-1969 Camaro/Firebird Billet Aluminum Throttle Pedal Assembly w/Rubber – Brushed
XBAG-6096	1967-1969 Camaro/Firebird Billet Aluminum Throttle Pedal Assembly w/Rubber – Black



Camaro/Firebird  
pedal shaft



Engine compartment  
side of Camaro/Firebird  
throttle pedal shaft

BAG-6096

### 1967 - 1969 Camaro/Firebird Traditional Flat Brake/Clutch Pads

Billet aluminum Brake and Clutch Pads are designed to match the Lokar Throttle Pedal Assemblies and are machined to fit over the stock steel pads with Lokar's exclusive mounting design. No drilling is needed and installation is simple. Traditional pads are available with ball-mill or rubber inserts and a brushed or black finish.

#### Part No. Description

BAG-6093	1967-1969 Camaro/Firebird Billet Aluminum Automatic Brake Pad – Brushed
BAG-6094	1967-1969 Camaro/Firebird Billet Aluminum Automatic Brake Pad w/Rubber – Brushed
XBAG-6094	1967-1969 Camaro/Firebird Billet Aluminum Automatic Brake Pad w/Rubber – Black
BAG-6100	1967-1968 Camaro/Firebird Billet Aluminum E-Brake Pad - Brushed
BAG-6099	1967-1968 Camaro/Firebird Billet Aluminum E-Brake Pad w/Rubber – Brushed
XBAG-6099	1967-1968 Camaro/Firebird Billet Aluminum E-Brake Pad w/Rubber – Black
BAG-6101	1967-1969 Camaro/Firebird Billet Aluminum Brake/Clutch Pad – Brushed
BAG-6102	1967-1969 Camaro/Firebird Billet Aluminum Brake/Clutch Pad w/Rubber Brushed
XBAG-6102	1967-1969 Camaro/Firebird Billet Aluminum Brake/Clutch Pad w/Rubber – Black



BAG-6101

BAG-6101

BAG-6102

BAG-6102

BAG-6091

BAG-6092

XBAG-6092



### 1967 - 1969 Camaro/Firebird Throttle Pads

If your set up requires that you retain the factory throttle linkage, but you still want an updated look inside the car, these Throttle Pads will do the trick. Throttle pad replaces the factory pad and mounts onto the factory arm and spring. Available with ball-mill or rubber inserts and a brushed or black finish.

#### Part No. Description

BAG-6091	1967-1969 Camaro/Firebird Billet Aluminum Throttle Pad – Brushed
BAG-6092	1967-1969 Camaro/Firebird Billet Aluminum Throttle Pad w/Rubber – Brushed
XBAG-6092	1967-1969 Camaro/Firebird Billet Aluminum Throttle Pad w/Rubber – Black



## 1967 - 1969 Curved Camaro/Firebird Brake/Clutch Pedal Pads

For a compact and clean look, Lokar has put a modern bend on classic brake/clutch pedal pads. Our Curved Brake/Clutch Pedal Pads add style and function to your classic car. Designed with hidden screws, these pads are curved to match and bolt directly to the factory steel brake pedal. Each brake pedal pad has been fashioned after its corresponding factory rubber pad and is available in brushed or black finish.

### Part No. Description

BAG-6133	1967-1969 Camaro/Firebird Billet Aluminum Curved Brake/Clutch Pad w/Rubber (Pair) - Brushed
XBAG-6133	1967-1969 Camaro/Firebird Billet Aluminum Curved Brake/Clutch Pad w/Rubber (Pair) - Black
BAG-6134	1967-1969 Camaro/Firebird Billet Aluminum Curved Automatic Brake Pad w/Rubber - Brushed
XBAG-6134	1967-1969 Camaro/Firebird Billet Aluminum Curved Automatic Brake Pad w/Rubber - Black
BAG-6159	1969-1981 Camaro/Firebird Billet Aluminum Curved E-Brake Pad w/Rubber
XBAG-6159	1969-1981 Camaro/Firebird Billet Aluminum Curved E-Brake Pad w/Rubber - Black
BAG-6161	1967-1968 Camaro/Firebird Billet Aluminum Curved E-Brake Pad w/Rubber
XBAG-6161	1967-1968 Camaro/Firebird Billet Aluminum Curved E-Brake Pad w/Rubber - Black



### ORDERING TIP

For a truly complete look, combine these brake pedal pads with one of our direct fit throttle pedal assemblies

## 1964 - 1967 CHEVELLE THROTTLE PEDAL ASSEMBLIES AND PEDAL PADS

**D**irect replacement Throttle Pedal Assemblies for 1964 - 1967 Chevelle with ball-milled pad or with rubber inserts eliminate the factory rod linkage, are designed to mount in the original firewall location and utilize a modern Lokar Throttle Cable system. The arms are splined for fine adjustment and can be switched for right and left adjustment of the throttle pad, which is spring-loaded and measures 2" x 5". Available in brushed or black finish.

For a compact and clean look, Lokar has put a modern bend on classic brake/clutch pedal pads. Our Curved Brake/Clutch Pedal Pads add style and function to your classic car. Designed with hidden screws, these pads are curved to match and bolt directly to the factory steel brake/clutch pedal. Each brake/clutch pedal pad has been fashioned after its corresponding factory rubber pad and is available in brushed or black finish.

### Part No. Description

BAG-6128	1964-1967 Chevelle Billet Aluminum Throttle Pedal Assembly - Brushed
BAG-6129	1964-1967 Chevelle Billet Aluminum Throttle Pedal Assembly w/Rubber - Brushed
XBAG-6129	1964-1967 Chevelle Billet Aluminum Throttle Pedal Assembly w/Rubber - Black
BAG-6132	1964-1972 Chevelle Billet Aluminum Curved Brake/Clutch Pad w/Rubber (Pair) - Brushed
XBAG-6132	1964-1972 Chevelle Billet Aluminum Curved Brake/Clutch Pad w/Rubber (Pair) - Black
BAG-6135	1964-1972 Chevelle Billet Aluminum Curved Automatic Brake Pad w/Rubber - Brushed
XBAG-6135	1964-1972 Chevelle Billet Aluminum Curved Automatic Brake Pad w/Rubber - Black
BAG-6163	1964-1975 Chevelle Billet Aluminum Curved E-Brake Pad w/Rubber
XBAG-6163	1964-1975 Chevelle Billet Aluminum Curved E-Brake Pad w/Rubber - Black

*Chevelle*  
BY CHEVROLET



## 1962 - 1972 CHEVY II/NOVA THROTTLE PEDAL ASSEMBLIES AND PEDAL PADS

Direct replacement Throttle Pedal Assemblies for 1962-1972 Chevy II/Nova with ball-milled pads or rubber inserts eliminate the factory rod linkage, are designed to mount in the original firewall location and utilize a modern Lokar Throttle Cable system. The arms are splined for fine adjustment and can be switched for right and left adjustment of the throttle pad, which is spring-loaded and measures 2" x 5". Available in brushed or black finish.

For a compact and clean look, Lokar has put a modern bend on classic brake/clutch pedal pads. Our Curved Brake/Clutch Pedal Pads add style and function to your classic car. Designed with hidden screws, these pads are curved to match and bolt directly to the factory steel brake/clutch pedal. Each brake/clutch pedal pad has been fashioned after its corresponding factory rubber pad and is available in brushed or black finish.



BAG-6127

BAG-6142



BAG-6143



BAG-6131



BAG-6130 (Pair)



XBAG-6131

XBAG-6130 (Pair)

XBAG-6127

### Part No. Description

BAG-6126	1962-1967 Chevy II/Nova Billet Aluminum Throttle Pedal Assembly - Brushed
BAG-6127	1962-1967 Chevy II/Nova Billet Aluminum Throttle Pedal Assembly w/Rubber - Brushed
XBAG-6127	1962-1967 Chevy II/Nova Billet Aluminum Throttle Pedal Assembly w/Rubber - Black
BAG-6130	1962-1972 Chevy II/Nova Billet Aluminum Curved Brake/Clutch Pad w/Rubber (Pair) - Brushed
XBAG-6130	1962-1972 Chevy II/Nova Billet Aluminum Curved Brake/Clutch Pad w/Rubber (Pair) - Black
BAG-6131	1962-1967 Chevy II/Nova Billet Aluminum Curved Automatic Brake Pad w/Rubber - Brushed
XBAG-6131	1962-1967 Chevy II/Nova Billet Aluminum Curved Automatic Brake Pad w/Rubber - Black
BAG-6142	1968-1972 Nova Billet Aluminum Throttle Pedal Assembly w/Rubber - Brushed
XBAG-6142	1968-1972 Nova Billet Aluminum Throttle Pedal Assembly w/Rubber - Black
BAG-6143	1968-1972 Nova Billet Aluminum Curved Automatic Brake Pad w/Rubber - Brushed
XBAG-6143	1968-1972 Nova Billet Aluminum Curved Automatic Brake Pad w/Rubber - Black
BAG-6160	1969-1974 Nova Billet Aluminum Curved E-Brake Pad w/Rubber
XBAG-6160	1969-1974 Nova Billet Aluminum Curved E-Brake Pad w/Rubber - Black
BAG-6162	1968 Nova Billet Aluminum Curved E-Brake Pad w/Rubber
XBAG-6162	1968 Nova Billet Aluminum Curved E-Brake Pad w/Rubber - Black



### TECH NOTE

Lokar's 1968-1972 Nova Throttle Pedal is designed to replace rod style throttle linkage only. Part Nos. BAG-6142 and XBAG-6142. To complete the installation use Lokar's Throttle Cables and Mounting Brackets.

## 1958 - 1962 CORVETTE BRAKE/CLUTCH PADS 1997 & LATER CORVETTE THROTTLE PADS/2005 - 2006 GTO

1958 - 1962 Corvette billet aluminum Curved Brake/Clutch Cover is machined to fit over the stock Corvette steel brake/clutch pads. Available in brushed or black finish. 1997 & later Corvette and 2005 - 2006 GTO throttle pads are designed as a direct fit replacement. Available in brushed or black finish.

### Features

- Replaces factory rubber pad
- Quick and easy installation
- No alignment problems
- Hardware included



BAG-6136 (Pair)

BAG-6150  
BAG-6158  
BAG-6157

FMG-6098  
(Recommended Throttle)

XBAG-6150  
XBAG-6158  
XBAG-6157

XBAG-6136 (Pair)

XFMG-6098  
(Recommended Throttle)

### Part No. Description

BAG-6110	1958-1962 Corvette Billet Aluminum Brake/Clutch w/Rubber - Brushed
XBAG-6110	1958-1962 Corvette Billet Aluminum Brake/Clutch w/Rubber - Black
BAG-6136	1958-1962 Corvette Billet Aluminum Curved Brake/Clutch Pad w/Rubber (Pair) - Brushed
XBAG-6136	1958-1962 Corvette Billet Aluminum Curved Brake/Clutch Pad w/Rubber (Pair) - Black
BAG-6150	2005 & Later Corvette Throttle Pad w/Rubber - Brushed
XBAG-6150	2005 & Later Corvette Throttle Pad w/Rubber - Black
BAG-6158	1997-2004 Corvette Throttle Pad w/Rubber - Brushed
XBAG-6158	1997-2004 Corvette Throttle Pad w/Rubber - Black
BAG-6157	2005-2006 Pontiac GTO Throttle Pad w/Rubber - Brushed
XBAG-6157	2005-2006 Pontiac GTO Throttle Pad w/Rubber - Black



## 1964 - 1970 MUSTANG THROTTLE PEDAL ASSEMBLIES & PEDAL PADS

Replace your worn out Mustang hard throttle linkage and pedal pads with Lokar's Mustang Throttle Assembly and Pedal Pads. Designed as a direct replacement for the stock assembly when paired with Lokar Throttle Cable and Brackets. Throw away your old stock hard linkages and get a high quality look that functions smoothly.



BAG-6117 1969 - 1970 Mounting



Engine compartment  
side of bracket



BAG-6115



BAG-6123



BAG-6121 (Pair)

### Features

- 6061-T6 Aluminum
- CNC machined for looks and durability
- Direct replacement for stock assemblies
- Spring-loaded Throttle Pedal
- Delrin® bushings for smooth pedal movement
- Rubber inserts on all pads for traction
- 3M black adhesive included for installing rubber inserts
- Easy to install with basic hand tools
- Available in brushed or black finish

### Benefits:

- Throttle Pedal is a direct fit in OEM firewall location for easy installation
- Use with Lokar Teflon®-lined Throttle and Kickdown Cables for complete conversion
- Provides ability to change from hard linkage to cable linkage
- Conversion to Lokar assemblies makes EFI swaps a breeze
- Improves adjustment capabilities when using an AOD transmission

### Part No. Description

BAG-6115	1964-1968 Mustang Billet Aluminum Throttle Pedal w/Rubber - Brushed
XBAG-6115	1964-1968 Mustang Billet Aluminum Throttle Pedal w/Rubber - Black
BAG-6117	1969-1970 Mustang Billet Aluminum Throttle Pedal w/Rubber - Brushed
XBAG-6117	1969-1970 Mustang Billet Aluminum Throttle Pedal w/Rubber - Black
BAG-6121	1964-1970 Mustang Billet Aluminum Brake/Clutch Pad Manual w/Rubber (Pair) - Brushed
XBAG-6121	1964-1970 Mustang Billet Aluminum Brake/Clutch Pad Manual w/Rubber (Pair) - Black
BAG-6123	1964-1968 Mustang Billet Aluminum Automatic Brake Pad w/Rubber - Brushed
XBAG-6123	1964-1968 Mustang Billet Aluminum Automatic Brake Pad w/Rubber - Black
BAG-6125	1969-1970 Mustang Billet Aluminum Automatic Brake Pad w/Rubber - Brushed
XBAG-6125	1969-1970 Mustang Billet Aluminum Automatic Brake Pad w/Rubber - Black



XBAG-6123

XBAG-6121 (Pair)



XBAG-6115

# CHEVY/GMC C-10 TRUCK THROTTLE PEDAL ASSEMBLIES AND CURVED PADS

Direct Fit Throttle  
Assemblies & Pedal Pads

Available for 1967-1970\* and 1971-1972

### Throttle Pedals Feature:

- Direct replacement (mounts into the factory location)
- Billet aluminum construction
- Adjustable upper and lower arms
- 48 tooth fine spline
- Delrin® bushings for smooth operation
- Compatible with Lokar cables
- Brushed or black finish

### Curved Pedal Pads Feature:

- Direct replacement
- Curved to match and bolt directly onto factory steel brake /clutch pedal arms
- Billet aluminum construction
- Hidden screws
- Rubber inserts for added traction
- Brushed or black finish

\*Replaces factory rod linkage with cable linkage

### Part No. Description

BAG-6164	1967-1970 Chevrolet/GMC C-10 Billet Alum. Throttle Pedal Assembly w/Rubber
XBAG-6164	1967-1970 Chevrolet/GMC C-10 Billet Alum. Throttle Pedal Assembly w/Rubber - Black
BAG-6165	1971-1972 Chevrolet/GMC C-10 Billet Alum. Throttle Pedal Assembly w/ Rubber
XBAG-6165	1971-1972 Chevrolet/GMC C-10 Billet Alum. Throttle Pedal Assembly w/Rubber - Black
BAG-6166	1967-1972 Chevrolet/GMC Billet Alum. Curved Automatic Brake Pad w/Rubber
XBAG-6166	1967-1972 Chevrolet/GMC Billet Alum. Curved Auto Brake Pad w/Rubber - Black
BAG-6167	1967-1972 Chevrolet/GMC Billet Alum. Curved Automatic Brake Pad w/Rubber (Long)
XBAG-6167	1967-1972 Chevrolet/GMC Billet Alum. Curved Auto Brake Pad w/Rubber (Long) - Black
BAG-6168	1967-1972 Chevrolet/GMC Billet Alum. Curved Manual Brake/Clutch Pad w/Rubber (Pair)
XBAG-6168	1967-1972 Chevrolet/GMC Billet Alum. Curved Manual Brake/Clutch Pad w/Rubber (Pair) - Black
BAG-6169	1967-1972 Chevrolet/GMC Billet Aluminum Curved E-Brake Pad w/Rubber
XBAG-6169	1967-1972 Chevrolet/GMC Billet Aluminum Curved E-Brake Pad w/Rubber - Black
BAG-6177	1971-1972 Chevrolet GMC C-10 Throttle Pedal Pad w/Rubber
XBAG-6177	1971-1972 Chevrolet GMC C-10 Throttle Pedal Pad w/Rubber - Black



1967-1970 Firewall Plate  
BAG-6164 Shown



BAG-6165



BAG-6169



BAG-6167



Back of BAG-6167



BAG-6168 (Pair)



BAG-6164



XBAG-6165



XBAG-6169



XBAG-6167



XBAG-6168 (Pair)



XBAG-6164



## LATE CHEVY TRUCK THROTTLE, BRAKE & EMERGENCY BRAKE PADS

### Late Chevy Truck Billet Aluminum Throttle Pad

#### Features

- Mounts onto factory arm and spring for Easy Installation
- Available in brushed or black finish

#### Part No. Description

BAG-6081	1973 - 1998 Chevy Truck Billet Aluminum Throttle Pad - Brushed
BAG-6085	1973 - 1998 Chevy Truck Billet Aluminum Throttle Pad w/Rubber - Brushed
XBAG-6085	1973 - 1998 Chevy Truck Billet Aluminum Throttle Pad w/Rubber - Black



### Late Chevy Truck Billet Aluminum Brake Pad

#### Features

- Billet Aluminum Brake Pad replaces factory rubber pad
- Quick and Easy Installation
- No drilling required
- No alignment problems
- Hardware included
- Available in brushed or black finish

#### Part No. Description

BAG-6082	1973 - 1975 Chevy Truck Billet Aluminum Automatic Brake Pad - Brushed
BAG-6086	1973 - 1975 Chevy Truck Billet Aluminum Automatic Brake w/Rubber - Brushed
XBAG-6086	1973 - 1975 Chevy Truck Billet Aluminum Automatic Brake Pad w/Rubber - Black
BAG-6083	1976 - 2003 Chevy Truck Billet Aluminum Automatic Brake Pad - Brushed
BAG-6087	1976 - 2003 Chevy Truck Billet Aluminum Automatic Brake Pad w/Rubber - Brushed
XBAG-6087	1976 - 2003 Chevy Truck Billet Aluminum Automatic Brake Pad w/Rubber - Black
BAG-6144	1976 - 2003 Chevy Truck Billet Aluminum Curved Automatic Brake Pad w/Rubber - Brushed
XBAG-6144	1976 - 2003 Chevy Truck Billet Aluminum Curved Automatic Brake Pad w/Rubber - Black



### Late Chevy Truck Billet Aluminum Brake & Clutch Pads

#### Part No. Description

BAG-6089	1988 - 1998 Chevy Truck Billet Aluminum Late Manual Brake/Clutch Pad - Brushed
BAG-6090	1988 - 1998 Chevy Truck Billet Aluminum Late Manual Brake/Clutch Pad w/Rubber - Brushed
XBAG-6090	1988 - 1998 Chevy Truck Billet Aluminum Late Manual Brake/Clutch Pad w/Rubber - Black

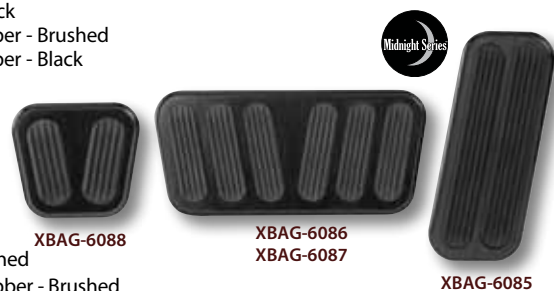

### Late Chevy Truck Billet Aluminum Emergency Brake

#### Features

- Replaces factory rubber pad
- Quick and Easy Installation
- No drilling required
- No alignment problems
- Hardware included
- Available in brushed or black finish

#### Part No. Description

BAG-6084	1973 - 2002 Chevy Truck Billet Aluminum Emergency Brake Pad - Brushed
BAG-6088	1973 - 2002 Chevy Truck Billet Aluminum Emergency Brake Pad w/Rubber - Brushed
XBAG-6088	1973 - 2002 Chevy Truck Billet Aluminum Emergency Brake Pad w/Rubber - Black



## EARLY FORD BRONCO THROTTLE PEDAL AND BRAKE/CLUTCH PADS



BAG-6181

BAG-6184  
BAG-6186

BAG-6182

BAG-6185 (Pair)

XBAG-6181

XBAG-6184  
XBAG-6186



XBAG-6182

**Part No. Description**

BAG-6181	1966-1977 Bronco Billet Aluminum Curved E-Brake Pad with Rubber
BAG-6182	1966-1977 Bronco Billet Aluminum Throttle Pedal Pad with Rubber
BAG-6183	1973-1977 Bronco Billet Aluminum Curved Automatic Non Power Brake Pad with Rubber
BAG-6184	1976-1977 Bronco Billet Aluminum Curved Automatic Power Brake Pad with Rubber
BAG-6185	1976-1977 Bronco Billet Aluminum Curved Brake/Clutch Pad with Rubber-Pair
BAG-6186	1966-1977 Bronco Billet Aluminum Curved Automatic XL Non Power Brake Pad with Rubber
XBAG-6181	Black 1966-1977 Bronco Billet Aluminum Curved E-Brake Pad with Rubber
XBAG-6182	Black 1966-1977 Bronco Billet Aluminum Throttle Pedal Pad with Rubber
XBAG-6183	Black 1973-1977 Bronco Billet Aluminum Curved Automatic Non Power Brake Pad with Rubber
XBAG-6184	Black 1976-1977 Bronco Billet Aluminum Curved Automatic Power Brake Pad with Rubber
XBAG-6185	Black 1976-1977 Bronco Billet Aluminum Curved Brake/Clutch Pad with Rubber-Pair
XBAG-6186	Black 1966-1977 Bronco Billet Aluminum Curved Automatic XL Non Power Brake Pad with Rubber

## BILLET ALUMINUM DIRECT FIT JEEP THROTTLE PEDAL ASSEMBLIES AND PEDAL PADS



BAG-6175

XBAG-6174 (Pair)

XBAG-6173

XBAG-6175

BAG-6176



XBAG-6176

BAG-6174 (Pair)

BAG-6173

**Part No. Description**

BAG-6173	1976-2006 Billet Aluminum Jeep Throttle Pedal Pad w/Rubber Fits CJ-5, CJ-7, CJ-8, Scrambler, Wrangler, YJ, TJ Unlimited, Cherokee, XJ
XBAG-6173	1976-2006 Billet Aluminum Jeep Throttle Pedal Pad w/Rubber Fits CJ-5, CJ-7, CJ-8, Scrambler, Wrangler, YJ, TJ Unlimited, Cherokee, XJ - Black
BAG-6174	1946-2010 Jeep, Wrangler, CJ, YJ, TJ, XJ Unlimited, Scrambler & Cherokee Curved Clutch & Brake Pad w/Rubber
XBAG-6174	1946-2010 Jeep, Wrangler, CJ, YJ, TJ, XJ Unlimited, Scrambler & Cherokee Curved Clutch & Brake Pad w/Rubber - Black
BAG-6175	1984-1996 Jeep Cherokee Automatic Curved Brake Pad w/Rubber
XBAG-6175	1984-1996 Jeep Cherokee Automatic Curved Brake Pad w/Rubber - Black
BAG-6176	1997-2001 Jeep Cherokee Automatic Curved Brake Pad w/Rubber
XBAG-6176	1997-2001 Jeep Cherokee Automatic Curved Brake Pad w/Rubber - Black



**MOPAR**

## 1967 - 1969 Dart/Cuda Competitor Series Throttle Assemblies & Pedal Pads

Lokar's Competitor Series Throttle Assemblies are designed with a unique internal spanner nut ensuring perfect pedal tension. This pedal is in a class of its own; by adding this built in tensioning feature, we have eliminated the possibility of excess 'slop' in the throttle pedal.

Another milestone of the Competitor Series Throttle Pedal is its incredibly sturdy mounting base. The design of this pedal has enabled us to provide over an inch and a quarter wide mounting base yet maintain a narrow and sleek appearance. If that weren't enough, the mounting base is mounted to a thick steel plate allowing the pedal to be installed in the vehicle using the factory mounting locations without any drilling or modification. This is incredibly accommodating when installing the pedal in a vehicle which has already been painted.

In our everlasting quest for perfection, we have also built the Competitor Series Throttle Assemblies with our exclusive large diameter 3/4" x 48 tooth fine-spline steel insert to provide the ultimate in strength and durability.

All of these features coupled with a spring-loaded throttle pad, Delrin® bushings, and superior design have made the Competitor Series Throttle Pedal the finest and most versatile throttle pedal available.

For a compact and clean look, Lokar has put a modern bend on classic brake/clutch pedal pads. Our Curved Brake/Clutch Pedal Pads add style and function to your classic car. Designed with hidden screws, these pads are curved to match and bolt directly to the factory steel brake/clutch pedal. Each brake/clutch pedal pad has been fashioned after its corresponding factory rubber pad and is available in brushed or black finish.



BAG-6147



BAG-6146 (Pair)



XBAG-6147

XBAG-6145



BAG-6145

XBAG-6146 (Pair)



**Part No. Description**

BAG-6145	1967 - 1969 Dart/Cuda Billet Aluminum Throttle Assembly w/Rubber - Brushed
XBAG-6145	1967 - 1969 Dart/Cuda Billet Aluminum Throttle Assembly w/Rubber - Black
BAG-6146	1967 - 1969 Dart/Cuda Billet Aluminum Curved Brake/Clutch Pad w/Rubber (Pair) - Brushed
XBAG-6146	1967 - 1969 Dart/Cuda Billet Aluminum Curved Brake/Clutch Pad w/Rubber (Pair) - Black
BAG-6147	1967 - 1969 Dart/Cuda Billet Aluminum Curved Automatic Brake Pad w/Rubber - Brushed
XBAG-6147	1967 - 1969 Dart/Cuda Billet Aluminum Curved Automatic Brake Pad w/Rubber - Black
BAG-6178	1967 - 1976 Billet Aluminum Throttle Pedal Assembly w/Rubber Fits Dart, Demon, Duster, Valiant, Scamp - Brushed
XBAG-6178	1967 - 1976 Billet Aluminum Throttle Pedal Assembly w/Rubber Fits Dart, Demon, Duster, Valiant, Scamp - Black
BAG-6179	1967 - 1976 Billet Aluminum Curved Brake/Clutch Pad w/Rubber (Pair) Fits Dart, Demon, Duster, Valiant, Scamp-Brushed
XBAG-6179	1967 - 1976 Billet Aluminum Curved Brake/Clutch Pad w/Rubber (Pair) Fits Dart, Demon, Duster, Valiant, Scamp-Black
BAG-6180	1967 - 1976 Billet Aluminum Curved Automatic Brake Pad w/Rubber Fits Dart, Demon, Duster, Valiant, Scamp-Brushed
XBAG-6180	1967 - 1976 Billet Aluminum Curved Automatic Brake Pad w/Rubber Fits Dart, Demon, Duster, Valiant, Scamp-Black

# BILLET ALUMINUM DIRECT FIT BRAKE AND CLUTCH PEDAL ARMS

Direct Fit assemblies are designed to replace original brake and clutch pedal arms.

## Features

- Direct replacement of the original brake & clutch pedal arms
- Billet aluminum construction
- Windowed arms complement other Lokar products
- Bronze pivot bushing for increased durability
- Unique styling
- Brushed or black finish

## Available For:

- Kugel Komponenten 90° & 180° degree pedal assemblies
- Tri-Five Chevy
- Camaro
- Chevelle
- Nova/Chevy II
- C-10 Truck

## Part No. Description

BCA-9500	90° Billet Aluminum Direct Fit Automatic Brake Pedal Arm with XL Oval Pad
XBCA-9500	90° Billet Alum Direct Fit Automatic Brake Pedal Arm with XL Oval Pad - Black
BCA-9501	90° Billet Aluminum Direct Fit Automatic Brake Pedal Arm with XL Pad
XBCA-9501	90° Billet Aluminum Direct Fit Automatic Brake Pedal Arm with XL Pad - Black
BCA-9502	90° Billet Alum Direct Fit Brake & Clutch Pedal Arm with Standard Oval Pad
XBCA-9502	90° Billet Alum Direct Fit Brake & Clutch Pedal Arm with Standard Oval Pad - Black
BCA-9503	90° Billet Aluminum Direct Fit Brake & Clutch Pedal Arm with Standard Pad
XBCA-9503	90° Billet Alum Direct Fit Brake & Clutch Pedal Arm with Standard Pad - Black
BCA-9504	180° Billet Aluminum Direct Fit Automatic Brake Pedal Arm with XL Oval Pad
XBCA-9504	180° Billet Alum Direct Fit Automatic Brake Pedal Arm with XL Oval Pad - Black
BCA-9505	180° Billet Aluminum Direct Fit Automatic Brake Pedal Arm with XL Pad
XBCA-9505	180° Billet Alum Direct Fit Automatic Brake Pedal Arm with XL Pad - Black
BCA-9506	180° Billet Alum Direct Fit Brake & Clutch Pedal Arm with Standard Oval Pad
XBCA-9506	180° Billet Alum Direct Fit Brake & Clutch Pedal Arm with Standard Oval Pad - Black
BCA-9507	180° Billet Alum Direct Fit Brake & Clutch Pedal Arm with Standard Pad
XBCA-9507	180° Billet Alum Direct Fit Brake & Clutch Pedal Arm with Standard Pad - Black
BCA-9508	67-72 Billet Aluminum Curved Chevy/GMC C-10 Direct Fit Automatic Brake Pedal Arm with Standard Pad
XBCA-9508	67-72 Billet Aluminum Curved Chevy/GMC C-10 Direct Fit Automatic Brake Pedal Arm with Standard Pad - Black
BCA-9509	67-72 Billet Aluminum Curved Chevy/GMC C-10 Direct Fit Automatic Brake Pedal Arm with Long Pad
XBCA-9509	67-72 Billet Aluminum Curved Chevy/GMC C-10 Direct Fit Automatic Brake Pedal Arm with Long Pad - Black
BCA-9510	67-72 Billet Aluminum Curved Chevy/GMC C-10 Direct Fit Brake & Clutch Pedal Arm with Standard Pad
XBCA-9510	67-72 Billet Aluminum Curved Chevy/GMC C-10 Direct Fit Brake & Clutch Pedal Arm with Standard Pad - Black
BCA-9511	55-57 Billet Aluminum Curved Chevy Direct Fit Automatic Brake Pedal Arm with Standard Pad
XBCA-9511	55-57 Billet Aluminum Curved Chevy Direct Fit Automatic Brake Pedal Arm with Standard Pad - Black
BCA-9512	55-57 Billet Aluminum Curved Chevy Direct Fit Automatic Brake Pedal Arm with Power Brake Pad
XBCA-9512	55-57 Billet Aluminum Curved Chevy Direct Fit Automatic Brake Pedal Arm with Power Brake Pad - Black
BCA-9513	55-57 Billet Aluminum Curved Chevy Direct Fit Brake & Clutch Pedal Arm with Standard Pad
XBCA-9513	55-57 Billet Aluminum Curved Chevy Direct Fit Brake & Clutch Pedal Arm with Standard Pad - Black



XBCA-9502



BCA-9501

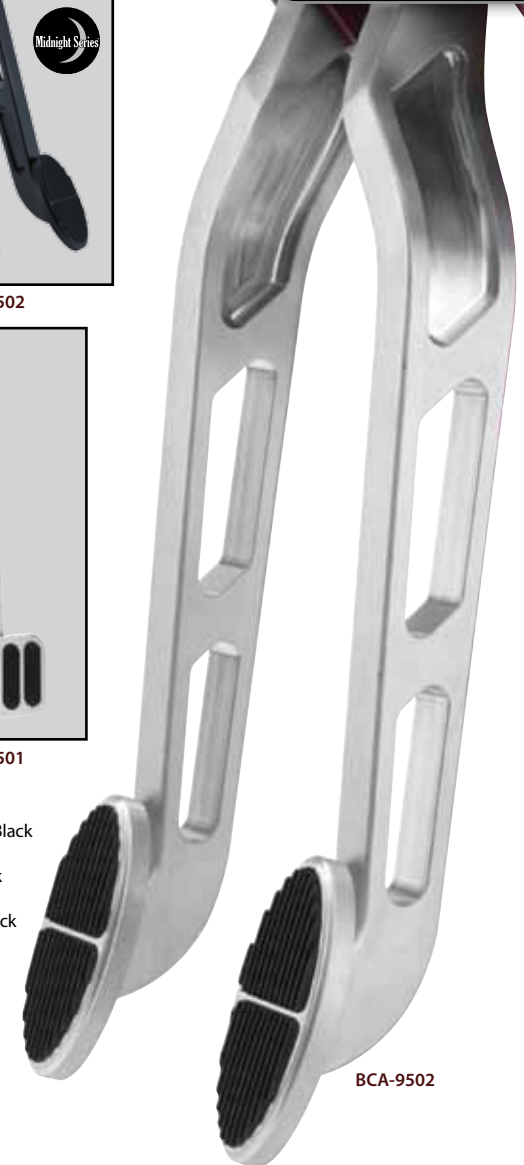

BCA-9502



BCA-9510



XBCA-9510



BCA-9513

## HI-TECH FLEXIBLE BRAIDED STAINLESS TRANSMISSION DIPSTICKS

You have flexibility with our Teflon®-lined Flexible Braided Stainless Transmission Dipstick. Kit comes complete with braided stainless outer housing and heat resistant E-Z to read flexible inner dipstick measuring cable. Inner cable is molded with appropriate trans fluid levels. Billet aluminum handle and billet aluminum fittings complement Lokar's Flexible Engine Dipsticks. Kit includes dipstick funnel adapter to assist in filling. Designed for "push in" style transmissions. Dipstick seals with double O-rings. Applications available for GM, Ford and Chrysler in both fire-wall mount and transmount. Firewall mount measures 24" in length. Transmount mounts to the bell housing and the length varies according to the transmission application. Kit comes complete with installation instructions.



### ORDERING TIP

Firewall mount recommended for full fendered cars and trucks. Special lengths available upon request.



Versatile firewall mount can be mounted onto firewall or anywhere in engine compartment

### Firewall Mount Dipsticks

Transmission	Stainless Steel	BLACK Stainless Steel
GM TH350	TD-3350400FM	XTD-3350400FM
GM TH400	TD-3350400FM	XTD-3350400FM
GM Powerglide	TD-30PGFM	XTD-30PGFM
GM 700-R4	TD-3700FM	XTD-3700FM
GM TH200	TD-3200FM	XTD-3200FM
GM 200-4R	TD-3200RFM	XTD-3200RFM
GM 4L60	TD-34L60FM	XTD-34L60FM
GM 4L60E/4L65E/4L70E	TD-34L60EFM	XTD-34L60EFM
GM 4L80E	TD-34L80FM	XTD-34L80FM
GM 6L80E/6L90E	TD-36L80FM	XTD-36L80FM
FORD C4	TD-30C4FM	XTD-30C4FM
FORD C4 PAN	TD-30C4FMPAN	XTD-30C4FMPAN
FORD C6	TD-30C6FM	XTD-30C6FM
FORD FMX	TD-3FMXFM	XTD-3FMXFM
FORD AOD/4R70W/AODE	TD-3AODFM	XTD-3AODFM
CHRYSLER 727	TD-3727FM	XTD-3727FM
CHRYSLER 904	TD-3904FM	XTD-3904FM
CHRYSLER 518	TD-3518FM	XTD-3518FM
CHRYSLER 45RFE	TD-345RFEFM	XTD-345RFEFM



### INSTALL TIP

Firewall mount can be mounted anywhere you desire under the hood such as the firewall or inner fender apron, etc. All firewall mount dipsticks are 24" in length.

Double O-Rings for Secure Seal



TRANSMISSION DIPSTICKS



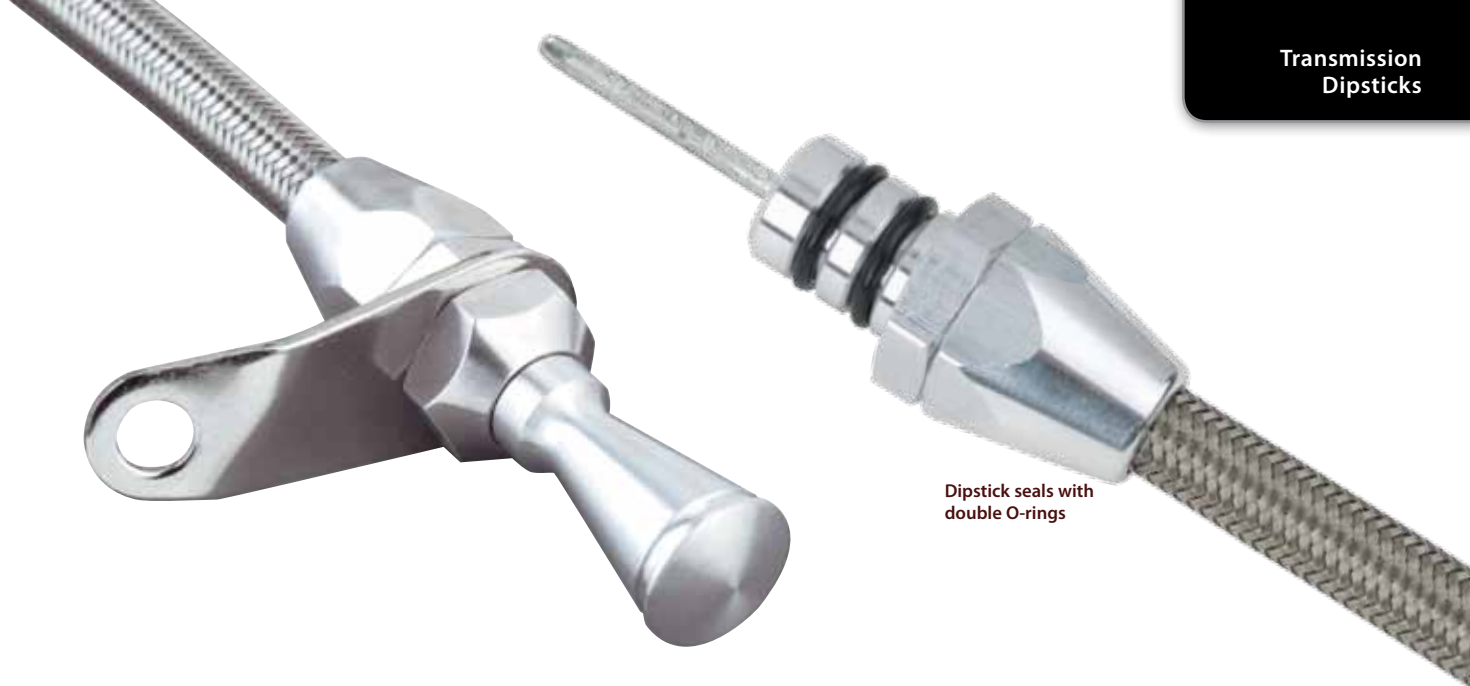

Dipstick seals with double O-rings



E-Z to Read Inner Cable



Funnel Adapter assists in filling transmission fluid (Included)

### Transmount Dipsticks

Transmission	Stainless Steel	BLACK Stainless Steel
GM TH350	TD-3350TM	XTD-3350TM
GM TH400	TD-3400TM	XTD-3400TM
GM Powerglide	TD-30PGTM	XTD-30PGTM
GM 700-R4	TD-3700TM	XTD-3700TM
GM TH200	TD-3200TM	XTD-3200TM
GM 200-4R	TD-3200RTM	XTD-3200RTM
GM 4L60	TD-34L60TM	XTD-34L60TM
GM 4L60E/4L65E/4L70E	TD-34L60ETM	XTD-34L60ETM
GM 4L80E	TD-34L80TM	XTD-34L80TM
GM 6L80E/6L90E	TD-36L80TM	XTD-36L80TM
FORD C4	TD-30C4TM	XTD-30C4TM
FORD C4 PAN	TD-30C4TMPAN	XTD-30C4TMPAN
FORD C6	TD-30C6TM	XTD-30C6TM
FORD FMX	TD-3FMXTM	XTD-3FMXTM
FORD AOD/4R70W/AODE	TD-3AODTM	XTD-3AODTM
CHRYSLER 727	TD-3727TM	XTD-3727TM
CHRYSLER 904	TD-3904TM	XTD-3904TM
CHRYSLER 518	TD-3518TM	XTD-3518TM
CHRYSLER 45RFE	TD-345RFETM	XTD-345RFETM



Transmount Dipstick



**Black Stainless Steel Housing**

# ANCHOR-TIGHT® LOCKING FLEXIBLE TRANSMISSION DIPSTICKS

**NHRA accepted for use in all categories of competition!**

**Features**

- No filler tube needed
- Locking mechanism prevents expulsion of dipstick handle under trans pressure
- Bolted in sealed pan fitting
- Large filler tube accepts standard transmission funnels
- Made from 6061-T6 aluminum
- Teflon®-lined stainless braided outer housing
- Flexible inner dipstick measuring cable
- No pan fitting leaks during storage
- Dipsticks available with firewall mount or transmount mounting bracket
- Trans & Firewall Mount styles supplied with trans storage plug for quick change & storage
- Spare trans fittings available for quick transmission changes
- Available for most GM, Ford and Chrysler transmissions
- Available in brite, black, red or blue anodized, and Black Stainless Steel



Pat. No.  
7,546,693

1209194

Flexible Dipstick  
with Firewall  
Mount Bracket

Pat. No.  
7,546,693

Available in Brite,  
Blue, Red or Black  
Anodized

3" Direct Mount

## APPLICATION CHART

Transmission	Style	Blue Part No.	Red Part No.	Brite Part No.	Black Part No.	Black SS Part No.
Powerglide OEM & Aftermarket	3" Direct Mount	1209121	1209122	1209124	1209127	X1209127
Powerglide OEM & Aftermarket	Transmount	1210131	1210132	1210134	1210137	X1210137
Powerglide OEM & Aftermarket	Firewall Mount	1210141	1210142	1210144	1210147	X1210147
Powerglide OEM & Aftermarket	Bottom Fitting Assembly for Spare Trans	1208111	1208112	1208114	1208117	X1208117
TH350/400	3" Direct Mount	1209141	1209142	1209144	1209147	X1209147
TH350	Transmount	1211131	1211132	1211134	1211137	X1211137
TH350/400	Firewall Mount	1211141	1211142	1211144	1211147	X1211147
TH400	Transmount	1213131	1213132	1213134	1213137	X1213137
TH350/400	Bottom Fitting Assembly for Spare Trans	1208141	1208142	1208144	1208147	X1208147
700-R4	3" Direct Mount	1209151	1209152	1209154	1209157	X1209157
700-R4	Transmount	1211231	1211232	1211234	1211237	X1211237
700-R4	Firewall Mount	1211241	1211242	1211244	1211247	X1211247
700-R4	Bottom Fitting Assembly for Spare Trans	1208131	1208132	1208134	1208137	X1208137
TH200	3" Direct Mount	1209161	1209162	1209164	1209167	X1209167
TH200	Transmount	1211331	1211332	1211334	1211337	X1211337
TH200	Firewall Mount	1211341	1211342	1211344	1211347	X1211347
TH200	Bottom Fitting Assembly for Spare Trans	1208161	1208162	1208164	1208167	X1208167
Chrysler 727/904/518	Direct Mount	1209171	1209172	1209174	1209177	X1209177
Chrysler 727	Transmount	1211431	1211432	1211434	1211437	X1211437
Chrysler 727/904/518	Firewall Mount	1211441	1211442	1211444	1211447	X1211447
Chrysler 727/904/518	Bottom Fitting Assembly for Spare Trans	1208171	1208172	1208174	1208177	X1208177
All Anchor Tight Dipsticks	Plug*	N/A	N/A	RP189	N/A	N/A
200-4R	3" Direct Mount	1209181	1209182	1209184	1209187	X1209187
200-4R	Transmount	1211731	1211732	1211734	1211737	X1211737
200-4R	Firewall Mount	1211741	1211742	1211744	1211747	X1211747
C4	Direct Mount	1209191	1209192	1209194	1209197	X1209197
C4	Firewall Mount	1211641	1211642	1211644	1211647	X1211647
C4/C6	Bottom Fitting Assembly for Spare Trans	1208181	1208182	1208184	1208187	X1208187
C6	Direct Mount	1209131	1209132	1209134	1209137	X1209137
C6	Firewall Mount	1211541	1211542	1211544	1211547	X1211547

\*Plug available in Brite finish only



1980 & later Small Block Chevy ED-5001 and GM Vortec Ram Jet 350 ED-5009

## FLEXIBLE ENGINE DIPSTICKS

Flexible Engine Dipstick designed with billet aluminum handle to coordinate with Lokar's Flexible Transmission Dipstick. Slim design allows mounting inside headers. Designed for use with factory, Sanderson cast manifolds or block hugger headers. Applications available for GM, Ford and Chrysler. E-Z read flexible inner dipstick measuring cable for accurate measure of engine oil.



### TECH NOTE

Some aftermarket oil pans may require a custom made dipstick.



### TECH NOTE

Small Block Chevy 1979 & Earlier is on the driver's side. Small Block Chevy 1980 & Later is on the passenger's side.



Early 289-302 Ford ED-5010



1979 & earlier Small Block Chevy ED-5002

Engine Make	Year/Style	Stainless Steel	BLACK Stainless Steel
Small Block Chevy	1980 & Later/Push into Block Passenger Side	ED-5001	XED-5001
Small Block Chevy	1979 & Earlier/Push into Block Driver's Side	ED-5002	XED-5002
302 Ford	1986 to 1995 5.0/Push into Block Driver's Side	ED-5004	XED-5004
351W Ford	NA/Screw into Pan Style 5/8"-18	ED-5005	XED-5005
Chevy II	1962-1967 283/327/Front Sump	ED-5007	XED-5007
GM LS1	1997 & Later (Car)	ED-5008	XED-5008
GM Vortec Ram Jet 350	5.7L Push into Block Passenger Side	ED-5009	XED-5009
Early 289-302 Ford	NA/thru timing chain cover	ED-5010	XED-5010
FE Ford	NA/ Push into Block Front Sump	ED-5012	XED-5012
302 Ford	NA/Crate Engine Only - Push into Pan	ED-5013	XED-5013
4.6 Modular Ford, 2 Valve	1994 & Later/Push into Block Driver's Side	ED-5014	XED-5014
Chrysler 5.7L & 6.1L Hemi	Rear Sump Pan (Truck) Push into Block Passenger Side	ED-5015	XED-5015
Ford Flathead V8	1937-1953 - Screw into Pan	ED-5016	XED-5016
302 Ford Roush	1/4" NPT pan gauge to fit	ED-5017	XED-5017
Dart Small Block Chevy	SHP (Special High Performance Block)	ED-5018	XED-5018
LS Series	1999 & Later Truck	ED-5019	XED-5019
LS Series	1997 & Later Car with Doug Thorley Tri-Y Headers	ED-5020	XED-5020
LS Series	1999 & Later Truck with Doug Thorley Tri-Y Headers	ED-5021	XED-5021
Chrysler 5.7L & 6.1L Hemi	Front Sump Pan (Car) Push into Pan Passenger Side	ED-5022	XED-5022
351 Cleveland Ford	1969-1974 (US), 1971-1984 (302-351 Australia)	ED-5023	XED-5023
253-308 Holden	1968-1984 (Australia)	ED-5024	XED-5024

ENGINE DIPSTICKS

## Big Block Flexible Engine Dipsticks

Flexible Engine Dipstick designed with billet aluminum handle to coordinate with Lokar's Flexible Transmission Dipstick. Slim design allows mounting inside headers. Designed for clearance with block hugger headers. E-Z read flexible inner dipstick measuring cable for accurate measure of engine oil.



ED-5003 and ED-5006



ED-5003 and ED-5006



ED-5011



ED-5011

Engine Make	Stainless Steel	BLACK SS
Chevy Big Block	ED-5003	XED-5003
Chevy Big Block 502	ED-5006	XED-5006
Ford Big Block 460 & 514	ED-5011 (Crate Motors Only)	XED-5011

## FLEXIBLE ENGINE DIPSTICK LOWER FITTINGS

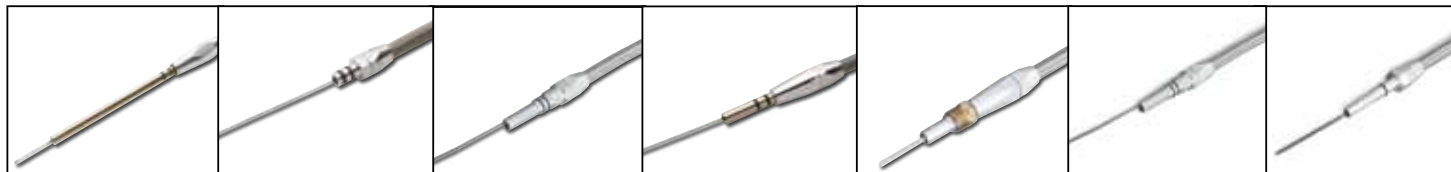

ED-5001 & ED-5009  
1220001 through 122007  
1220081 through 122087

ED-5002  
1220011 through 1220017

ED-5003 & ED-5006  
1220021 through 1220027  
1220051 through 1220057

ED-5004  
1220031 through 1220037

ED-5005  
1220041 through 1220047

ED-5007  
1220061 through 1220067

ED-5008, ED-5019, ED-5020,  
& ED-5021  
1220071 through 1220077



ED-5010  
1220091 through 1220097

ED-5011  
1220101 through 1220107

ED-5012  
1220111 through 1220117

ED-5013  
1220121 through 1220127

ED-5014  
1220131 through 1220137

ED-5015  
1220141 through 1220147

ED-5016  
1220151 through 1220157

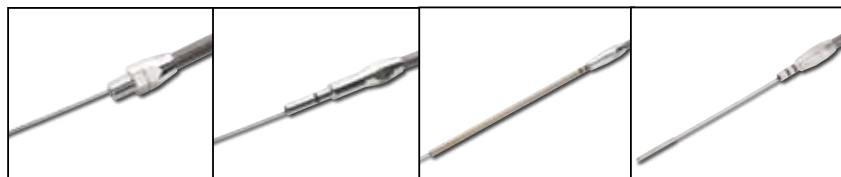

ED-5017  
1220171 through 1220177

ED-5018  
1220181 through 1220187

ED-5023  
1220251 through 1220257

ED-5026  
1220261 through 1220267

## Billet Aluminum Engine Dipstick Small Block Chevy

Billet aluminum and stainless Dipstick for pre-1980 Small Block Chevy. Application is straight into the engine block – no upper tube necessary. Dipstick seals at bottom of handle with double O-rings. Billet aluminum handle designed to coordinate with Lokar Flexible Transmission Dipstick.

Engine Make	Year	Hi-Tech	BLACK
Small Block Chevy	1979 & Earlier (No Upper Tube)	ED-5000ESB	XED-5000ESB



ED-5000ESB

XED-5000ESB

# ANCHOR-TIGHT® LOCKING FLEXIBLE ENGINE DIPSTICKS

Engine  
Dipsticks

**NHRA accepted for use in all categories of competition!**

- Locking mechanism prevents expulsion of dipstick handle under pressure
- Holds vacuum
- Teflon®-lined stainless braided outer housing
- E-Z to read flexible inner dipstick measuring cable
- Available for most engine applications
- Available in brite, black, red or blue anodized, and Black Stainless Steel



U.S. Patent No. 7,779,555



## APPLICATION CHART

Engine	Year	Style	Blue Part No.	Red Part No.	Brite Part No.	Black Part No.	Black SS Part No.
Chevy 502 Big Block	N/A	Push into Pan	1220051	1220052	1220054	1220057	X1220057
Chevy Big Block	N/A	Push into Pan	1220021	1220022	1220024	1220027	X1220027
Chevy II V-8 283/327 Front Sump	1962 thru 1967	Push into Pan Passenger's side	1220061	1220062	1220064	1220067	X1220067
Chevy Small Block	1980 & Later	Push into Block Passenger's side	1220001	1220002	1220004	1220007	X1220007
Chevy Small Block	1979 & Earlier	Push into Block Driver's side	1220011	1220012	1220014	1220017	X1220017
Chevy Small Block Ram Jet 350	N/A	Push into Block Passenger's side	1220081	1220082	1220084	1220087	X1220087
Chrysler 5.7L & 6.1L Hemi	N/A	Rear Sump Pan (Truck) Push into Block Passenger Side	1220141	1220142	1220144	1220147	X1220147
Ford 302	N/A	Crate Only Push into Pan	1220121	1220122	1220124	1220127	X1220127
Ford 302 5.0L	1986 thru 1995	Push into Block Driver's side	1220031	1220032	1220034	1220037	X1220037
Ford 351W	N/A	Screw into Pan 5/8"-18	1220041	1220042	1220044	1220047	X1220047
Ford 4.6 Modular, 2 Valve	1994 & Later	Push into Block Driver's side	1220131	1220132	1220134	1220137	X1220137
Ford Big Block 460 & 514	N/A	Crate Only Push into Pan	1220101	1220102	1220104	1220107	X1220107
Ford Early 289-302	N/A	Through Timing Chain Cover	1220091	1220092	1220094	1220097	X1220097
Ford FE	N/A	Push into Block Front Sump	1220111	1220112	1220114	1220117	X1220117
Ford V8 Flathead	1937 thru 1953	Screw into Pan	1220151	1220152	1220154	1220157	X1220157
GM LS1	1997 & Later	Push into Block Passenger's side	1220071	1220072	1220074	1220077	X1220077
GM Small Block Vortec	1996 thru 2000	5.7L Push into Block Passenger's side	1220081	1220082	1220084	1220087	X1220087
Universal	N/A	1/4" NPT Pan Fitting Gauge to Fit -12" Housing length; extra long inner rod	1220171	1220172	1220174	1220177	X1220177
Dart Small Block Chevy	N/A	Special High Performance Block	1220181	1220182	1220184	1220187	X1220187
LS Series	1999 & Later	Truck	1220211	1220212	1220214	1220217	X1220217
LS Series	1997 & Later	Car with Doug Thorley Tri-Y Headers	1220221	1220222	1220224	1220227	X1220227
LS Series	1999 & Later	Truck with Doug Thorley Tri-Y Headers	1220231	1220232	1220234	1220237	X1220237
Chrysler 5.7L & 6.1L Hemi	N/A	Front Sump Pan (Car) Push into Pan Passenger Side	1220241	1220242	1220244	1220247	X1220247
351 Cleveland Ford	1969 thru 1984	69-74 (US), 71-84 (302-351 Australia)	1220251	1220252	1220254	1220257	X1220257

EXTERIOR PRODUCTS



SP-1501HT



SP-1500U

### U-Cut-to-Fit Speedometer Cable Kits

Premium housing designed with a specially extruded liner for extended life of the cable and billet aluminum fittings. Inner cable and outer housing are "U-Cut-to-Fit". Kit comes complete with all fittings and is available for GM, Ford and Chrysler applications. (Gauges not included)

Lokar Speedometer Cables are designed to work with most cable driven aftermarket speedometer gauges (such as Auto Meter, Stewart Warner, VDO, Classic Instruments, etc.) or factory speedometer with a 5/8"-18 male thread at the speedo.

Lokar Speedometer Cables are designed to fit into the transmission gear adapter (not supplied in Chevy or Chrysler Lokar Kit). Customer must have the trans end adapter and speedometer gear for all Chevy and Chrysler applications. For Ford applications, the gear adapter is supplied in the Lokar Kit. Customer must supply the speedo gear and speedo gear retainer clip.

All Lokar Speedometer Cables are seven feet (7') long and designed to be "U-Cut-to-Fit". Additional length cable in black or stainless housing is available upon request for an additional charge.

Application	Part No.	Description
Chevy TH350, TH400, 700-R4, Powerglide, TH200, 200-4R & 4L60 Chrysler 727 & 904	SP-1500U	Black Housing Speedo
	SP-1501HT	Stainless Housing Speedo
Ford C4, C6, AOD and FMX	SP-1502U	Black Housing Speedo
	SP-1503HT	Stainless Housing Speedo
Early Ford Speedo with Chevy/Chrysler trans (1948 and earlier original speedo)*	SP-1504U	Black Housing Speedo
	SP-1505HT	Stainless Housing Speedo
Early Ford Speedo with Ford trans (1948 and earlier original speedo)*	SP-1506U	Black Housing Speedo
	SP-1507HT	Stainless Housing Speedo

*\*Must have a 3/4"-20 female thread at the speedometer*



SP-1500U      SP-1501HT      SP-1502U      SP-1503HT



SP-1504U      SP-1505HT      SP-1506U      SP-1507HT



Transmission End Attachment



Speedo End Attachment

## Award Winning Billet Aluminum Oval LED Taillights

### Features

#### • RECIPIENT OF THE NSRA SAFETY AWARD

- Chrome plated or black powder coated for ultimate shine and easy detailing
- CNC machined from 6061-T6 Billet Aluminum
- Bright LED lights for safety and function
- Integrated design with 3 functions: tail, turn and brakes
- Extremely bright LEDs, generate virtually no heat, use little power and have long life
- Fully assembled for easy installation
- Detailed instructions with color coded wiring for easy installation
- Oval style with smooth recessed lens and internal prism
- Design matches other Lokar Oval style products
- Stainless hardware and zinc plated mounting brackets
- Low profile design
  - 1-1/4" total thickness
  - Requires a mere 1-1/2" behind body panel for mounting
  - Protrudes less than 3/16" from outside of body panel
- Offered in two sizes
  - Standard: Outer Bezel measures 2-3/4" x 5-1/2"
  - XL: Outer Bezel measures 3" x 6-1/2"

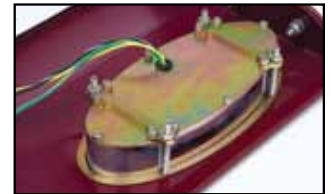

### Part No. Description

- |          |   |
|----------|---|
| TL-1910  | Standard Billet Aluminum Oval LED Taillights (Pair) - Chromed |
| XTL-1910 | Standard Billet Aluminum Oval LED Taillights (Pair) - Black   |
| TL-1911  | XL Billet Aluminum Oval LED Taillights (Pair) - Chromed       |
| XTL-1911 | XL Billet Aluminum Oval LED Taillights (Pair) - Black         |



3 Level Hood and Trunk Prop

6 Level Hood and Trunk Prop

## Award Winning

### Adjustable-Level Self-Locking Hood and Trunk Prop

**SEMA BEST NEW ACCESSORY PRODUCT** Constructed of high quality billet aluminum and stainless steel, this Adjustable-Level Hood and Trunk Prop will offer great looks, as well as functionality to your ride. When the hood or trunk is raised, the Hood and Trunk Prop will automatically lock itself into position. This eliminates the need for two hands when opening your hood or trunk. A quick release allows the hood to be opened to its max for easy engine access. We offer two versions of the Hood and Trunk Prop, a three level and six level. This will allow the hood or trunk to be set at various levels without any unsightly objects holding it up. Each level of the six-level prop increases the opening of the hood or trunk by approximately 6 inches. Each level of the three-level prop increases the opening of the hood or trunk by approximately 12 inches.

### Part No. Description

- |          |   |
|----------|---|
| 0401014  | Adjustable 3 level Hood and Trunk Prop - Polished |
| 0401024  | Adjustable 6 level Hood and Trunk Prop - Polished |
| X0401014 | Adjustable 3 Level Hood and Trunk Prop - Black    |
| X0401024 | Adjustable 6 Level Hood and Trunk Prop - Black    |

### Special Order Colors

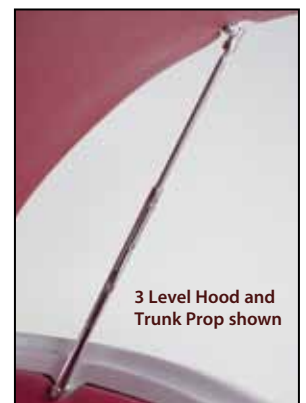
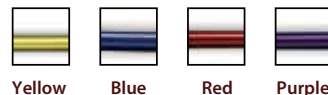

3 Level Hood and Trunk Prop shown

### TECH NOTE

**3 position Hood and Trunk Prop Measurements:**  
Collapsed: 12" Extended: 19-3/4" Level Spacing: 2-1/4"

**6 position Hood and Trunk Prop Measurements:**  
Collapsed: 12" Extended: 19-3/4" Level Spacing: 1-1/8"



## Billet Exterior 12 Volt Door Handles

Billet exterior 12 volt door handles are a great way to elevate your vehicle to the next level. Lokar's door handles utilize a 12 volt pressure pad switch to supply power to the electric actuated door latches.

- Two piece design with removable insert for customization
- Weather proof 12 volt touch pad switch
- Available with a 0 or 10 degree mounting surface
- Machined from 6061-T-6 billet aluminum
- Stainless steel hardware included
- Available in brushed or polished finish

<u>Part No.</u>	<u>Description</u>
GSE-2100	0 Degree Billet Exterior 12 Volt Door Handle - Brushed
GSE-2101	0 Degree Billet Exterior 12 Volt Door Handle - Polished
GSE-2102	10 Degree Billet Exterior 12 Volt Door Handle - Brushed
GSE-2103	10 Degree Billet Exterior 12 Volt Door Handle - Polished



### **TECH NOTE**

The Billet Exterior 12 Volt Door Handles are designed to be used with a pocket for hand clearance.





## U-Cut-to-Fit Cruise Control Cables

Lokar Cruise Control Cable is for use with "Rostra" Control kits. Kit includes 4' stainless outer housing designed with a specially extruded liner for extended life of the cable and 5' of stainless inner wire, which replaces the black plastic cable in Rostra Kits. Cables are "U-Cut-to-Fit" inside and outside of firewall. All billet aluminum fittings and stainless hold down clamp and mounting bracket. Mount cable to carburetor with Lokar's Stainless Carburetor Bracket and Return Springs, Part No. SRK-4000.

Part No.	Description
CC-1600U	Carbureted Cruise Control Cable - Black
CC-1601HT	Carbureted Cruise Control Cable - Stainless
CC-1602U	Tuned-Port Cruise Control Cable - Black
CC-1603HT	Tuned-Port Cruise Control Cable - Stainless
XCC-1601HT	Cruise Control Cable Black SS Housing w/Black Aluminum Fittings
XCC-1603HT	Tuned-Port Cruise Control Cable Black SS Housing w/Black Aluminum Fittings



CC-1601HT



CC-1602U

## Anchor-Tight® Headlight Braid

**N**o, this is not just another headlight conduit! This is Lokar's design technology for "U-Cut-to-Fit", non-kinking stainless steel headlight braid. Designed with threaded steel studs to insure that you won't experience any of the typical separation between braid and fitting that shows unsightly wires out in the open. Pull, tug or bump your headlight braid and it will stay in place, leaving you with protected wires and a clean set up. Kit comes complete with two 14" flexible braided stainless steel Teflon®-lined housings, threaded STEEL studs, billet aluminum fittings, aluminum grill shell washers and four 26" headlight wires.

Part No.	Description
HL-1900	Anchor-Tight® Stainless Steel Headlight Braid
XHL-1900	Black Anchor-Tight® Stainless Steel Headlight Braid



Midnight Series™

## LOKAR COMPONENT PARTS

These are component parts to many of our stock kits. If you lose a part, cut a part too short or simply want to change your shifter lever length, you can do so easily by calling in and placing an order. All Lokar Shifter Levers can be changed to any of the many lever lengths we offer. Many of our distributors are carrying these component parts on a regular basis so that they may assist you quickly and efficiently. Be sure to check with a dealer near you.



**Carb End for Lokar Throttle Cables**  
Part # S-1034



**Throttle Cable Inner Wire for Lokar Cables**  
Part # S-1041 36"  
Part # S-1042 48"



**Neutral Safety Switch for Lokar Shifters**  
Part # S-68154



5/16" - 24

1/4" - 28

**Rod Ends 5/16" - 24 and 1/4" - 28 (Sold in Pairs)**  
Part # S-68155 1/4" - 28  
Part # S-68156 5/16" - 24



**1-1/2" Shielded Pulley Assembly (Sold in Pairs)**  
Part # S-2105

### Lever Conversion Kits

Description	Chromed	Black Powder Coated
23" Shifter Lever & Inner Rod	S-68144	XS-68144
23" Nostalgia Shifter Lever & Inner Rod	S-68145	XS-68145
16" Shifter Lever & Inner Rod	S-68146	XS-68146
16" Nostalgia Shifter Lever & Inner Rod	S-68147	XS-68147
12" Shifter Lever & Inner Rod	S-68148	XS-68148
10" Shifter Lever & Inner Rod	S-68149	XS-68149
8" Shifter Lever & Inner Rod	S-68150	XS-68150
6" Shifter Lever & Inner Rod	S-68151	XS-68151
32" Single Bend Shifter Lever & Inner Rod	S-68152	XS-68152
32" Double Bend Shifter Lever & Inner Rod	S-68153	XS-68153



**Chromed and Black Levers and Inner Rods for Lokar Shifters**

**Threaded Rod for Lokar Shifters 1/4" - 28, 15" long**  
Part # S-6996



## INTERIOR BATTERY DISCONNECT LEVER KIT

### Features

- Turn electrical power on or off from the driver's seat
- **Lokar Direct-Mount™ Lever Kit** fits B&M® Pro Bandit, Quarter Pro®, Precision Performance Products Shifters
- **Lokar Vari-Mount™ Lever Kit** fits B&M® Pro Ratchet, TCI Thunder Stick™, TCI Outlaw™, TCI Lightning™ and Hurst Quarter Stick® shifters or can be mounted to the floor
- Red anodized billet aluminum power lever for quick recognition
- Works in conjunction with fire system kill switch
- Master power switch available in 125 or 300 amp
- Kit standard with 8' push pull cable
- Push Pull Cables also available in 6' and 7'
- Mounting hardware included
- Kit available without the Master Power Switch



### Part No. Description

- |         |   |
|---------|---|
| 1330011 | Lokar Direct Mount™ Fits B&M® Pro Bandit, Quarter Pro, Precision Performance Products Shifters - 125 Amp  |
| 1330012 | Lokar Direct Mount™ Fits B&M® Pro Bandit, Quarter Pro, Precision Performance Products Shifters - 300 Amp  |
| 1330013 | Lokar Direct Mount™ Fits B&M® Pro Bandit, Quarter Pro, Precision Performance Products Shifters - No Switch  |
| 1330021 | Lokar Vari-Mount™ Fits B&M® Pro Ratchet, TCI Thunder Stick™, TCI Outlaw™, TCI Lightning™, Hurst Quarter Stick® Shifters or can be mounted to the floor - 125 Amp Switch |
| 1330022 | Lokar Vari-Mount™ Fits B&M® Pro Ratchet, TCI Thunder Stick™, TCI Outlaw™, TCI Lightning™, Hurst Quarter Stick® Shifters or can be mounted to the floor - 300 Amp Switch |
| 1330023 | Lokar Vari-Mount™ Fits B&M® Pro Ratchet, TCI Thunder Stick™, TCI Outlaw™, TCI Lightning™, Hurst Quarter Stick® Shifters or can be mounted to the floor - No Switch      |



DRAG RACING PRODUCTS



## ANCHOR-TIGHT® LOCKING FLEXIBLE ENGINE DIPSTICKS



U.S. Patent No. 7,779,555



**NHRA accepted for use in all categories of competition!**

- Locking mechanism prevents expulsion of dipstick handle under pressure
- Holds vacuum
- Teflon®-lined stainless braided outer housing
- E-Z to read flexible inner dipstick measuring cable
- Available for most engine applications
- Available in brite, black, red or blue anodized, and Black Stainless Steel



### APPLICATION CHART

Engine	Year	Style	Blue Part No.	Red Part No.	Brite Part No.	Black Part No.	Black SS Part No.
Chevy 502 Big Block	N/A	Push into Pan	1220051	1220052	1220054	1220057	X1220057
Chevy Big Block	N/A	Push into Pan	1220021	1220022	1220024	1220027	X1220027
Chevy II V-8 283/327 Front Sump	1962 thru 1967	Push into Pan Passenger's side	1220061	1220062	1220064	1220067	X1220067
Chevy Small Block	1980 & Later	Push into Block Passenger's side	1220001	1220002	1220004	1220007	X1220007
Chevy Small Block	1979 & Earlier	Push into Block Driver's side	1220011	1220012	1220014	1220017	X1220017
Chevy Small Block Ram Jet 350	N/A	Push into Block Passenger's side	1220081	1220082	1220084	1220087	X1220087
Chrysler 5.7L & 6.1L Hemi	N/A	Rear Sump Pan (Truck) Push into Block Passenger Side	1220141	1220142	1220144	1220147	X1220147
Ford 302	N/A	Crate Only Push into Pan	1220121	1220122	1220124	1220127	X1220127
Ford 302 5.0L	1986 thru 1995	Push into Block Driver's side	1220031	1220032	1220034	1220037	X1220037
Ford 351W	N/A	Screw into Pan 5/8"-18	1220041	1220042	1220044	1220047	X1220047
Ford 4.6 Modular, 2 Valve	1994 & Later	Push into Block Driver's side	1220131	1220132	1220134	1220137	X1220137
Ford Big Block 460 & 514	N/A	Crate Only Push into Pan	1220101	1220102	1220104	1220107	X1220107
Ford Early 289-302	N/A	Through Timing Chain Cover	1220091	1220092	1220094	1220097	X1220097
Ford FE	N/A	Push into Block Front Sump	1220111	1220112	1220114	1220117	X1220117
Ford V8 Flathead	1937 thru 1953	Screw into Pan	1220151	1220152	1220154	1220157	X1220157
GM LS1	1997 & Later	Push into Block Passenger's side	1220071	1220072	1220074	1220077	X1220077
GM Small Block Vortec	1996 thru 2000	5.7L Push into Block Passenger's side	1220081	1220082	1220084	1220087	X1220087
Universal	N/A	1/4" NPT Pan Fitting Gauge to Fit -12" Housing length; extra long inner rod	1220171	1220172	1220174	1220177	X1220177
Dart Small Block Chevy	N/A	Special High Performance Block	1220181	1220182	1220184	1220187	X1220187
LS Series	1999 & Later	Truck	1220211	1220212	1220214	1220217	X1220217
LS Series	1997 & Later	Car with Doug Thorley Tri-Y Headers	1220221	1220222	1220224	1220227	X1220227
LS Series	1999 & Later	Truck with Doug Thorley Tri-Y Headers	1220231	1220232	1220234	1220237	X1220237
Chrysler 5.7L & 6.1L Hemi	N/A	Front Sump Pan (Car) Push into Pan Passenger Side	1220241	1220242	1220244	1220247	X1220247
351 Cleveland Ford	1969 thru 1984	69-74 (US), 71-84 (302-351 Australia)	1220251	1220252	1220254	1220257	X1220257



## ANCHOR-TIGHT® LOCKING FLEXIBLE TRANSMISSION DIPSTICKS

**NHRA accepted for use in all categories of competition!**

### Features

- No filler tube needed
- Locking mechanism prevents expulsion of dipstick handle under trans pressure
- Bolted in sealed pan fitting
- Large filler tube accepts standard transmission funnels
- Made from 6061-T6 aluminum
- Teflon®-lined stainless braided outer housing
- Flexible inner dipstick measuring cable
- No pan fitting leaks during storage
- Dipsticks available with firewall mount or transmount mounting bracket
- Trans & Firewall Mount styles supplied with trans storage plug for quick change & storage
- Spare trans fittings available for quick transmission changes
- Available for most GM, Ford and Chrysler transmissions
- Available in brite, black, red or blue anodized, and Black Stainless Steel

1209194



Midnight Series



Flexible Dipstick  
with Firewall  
Mount Bracket

Pat. No.  
7,546,693



Available in Brite,  
Blue, Red or Black  
Anodized

3" Direct Mount

### APPLICATION CHART

Transmission	Style	Blue Part No.	Red Part No.	Brite Part No.	Black Part No.	Black SS Part No.
Powerglide OEM & Aftermarket	3" Direct Mount	1209121	1209122	1209124	1209127	X1209127
Powerglide OEM & Aftermarket	Transmount	1210131	1210132	1210134	1210137	X1210137
Powerglide OEM & Aftermarket	Firewall Mount	1210141	1210142	1210144	1210147	X1210147
Powerglide OEM & Aftermarket	Bottom Fitting Assembly for Spare Trans	1208111	1208112	1208114	1208117	X1208117
TH350/400	3" Direct Mount	1209141	1209142	1209144	1209147	X1209147
TH350	Transmount	1211131	1211132	1211134	1211137	X1211137
TH350/400	Firewall Mount	1211141	1211142	1211144	1211147	X1211147
TH400	Transmount	1213131	1213132	1213134	1213137	X1213137
TH350/400	Bottom Fitting Assembly for Spare Trans	1208141	1208142	1208144	1208147	X1208147
700-R4	3" Direct Mount	1209151	1209152	1209154	1209157	X1209157
700-R4	Transmount	1211231	1211232	1211234	1211237	X1211237
700-R4	Firewall Mount	1211241	1211242	1211244	1211247	X1211247
700-R4	Bottom Fitting Assembly for Spare Trans	1208131	1208132	1208134	1208137	X1208137
TH200	3" Direct Mount	1209161	1209162	1209164	1209167	X1209167
TH200	Transmount	1211331	1211332	1211334	1211337	X1211337
TH200	Firewall Mount	1211341	1211342	1211344	1211347	X1211347
TH200	Bottom Fitting Assembly for Spare Trans	1208161	1208162	1208164	1208167	X1208167
Chrysler 727/904/518	Direct Mount	1209171	1209172	1209174	1209177	X1209177
Chrysler 727	Transmount	1211431	1211432	1211434	1211437	X1211437
Chrysler 727/904/518	Firewall Mount	1211441	1211442	1211444	1211447	X1211447
Chrysler 727/904/518	Bottom Fitting Assembly for Spare Trans	1208171	1208172	1208174	1208177	X1208177
All Anchor Tight Dipsticks	Plug*	N/A	N/A	RP189	N/A	N/A
200-4R	3" Direct Mount	1209181	1209182	1209184	1209187	X1209187
200-4R	Transmount	1211731	1211732	1211734	1211737	X1211737
200-4R	Firewall Mount	1211741	1211742	1211744	1211747	X1211747
C4	Direct Mount	1209191	1209192	1209194	1209197	X1209197
C4	Firewall Mount	1211641	1211642	1211644	1211647	X1211647
C4/C6	Bottom Fitting Assembly for Spare Trans	1208181	1208182	1208184	1208187	X1208187
C6	Direct Mount	1209131	1209132	1209134	1209137	X1209137
C6	Firewall Mount	1211541	1211542	1211544	1211547	X1211547

\*Plug available in Brite finish only



## LOKAR DIAL-IN BOARD, CAGE MOUNT AND UNIVERSAL ADJUSTABLE ANGLE MOUNT

Cage and Universal Adjustable Angle Mount Dial-In Board and Brackets are manufactured with 6061-T6 aluminum featuring a ball-milled design. Mounts onto cage without interfering with roll-bar padding. No drilling required for mounting to the cage. Bracket available for 1-1/2" cages and 1-5/8" cages. Offered in polished, black or clear finishes. Features an adjustable arm for leveling and a quickly reversible dial-in board. Also available in a universal adjustable angle mount style which can be mounted on a flat or angled surface such as a scoop tray.



Universal Adjustable Angle Mount Bracket

Part No.	Description
1110104	1-1/2" Dial-In Board Cage Mount - Polished
1110107	1-1/2" Dial-In Board Cage Mount - Black
1110108	1-1/2" Dial-In Board Cage Mount - Clear
1110114	1-5/8" Dial-In Board Cage Mount - Polished
1110117	1-5/8" Dial-In Board Cage Mount - Black
1110118	1-5/8" Dial-In Board Cage Mount - Clear
1110124	Universal Adjustable Angle Mount - Polished
1110127	Universal Adjustable Angle Mount - Black
1110128	Universal Adjustable Angle Mount - Clear
1110134	Universal Adjustable Angle Mount for MEGA Dial-In Board - Polished
1110137	Universal Adjustable Angle Mount for MEGA Dial-In Board - Black
1110138	Universal Adjustable Angle Mount for MEGA Dial-In Board - Clear
1110144	1-1/2" Dial-In Board Cage Mount for MEGA Dial-In Board - Polished
1110147	1-1/2" Dial-In Board Cage Mount for MEGA Dial-In Board - Black
1110148	1-1/2" Dial-In Board Cage Mount for MEGA Dial-In Board - Clear



Cage Mount



## BILLET ALUMINUM SAFETY LED TAILLIGHT

### Features

- 1-1/4" Billet 6061-T6 aluminum taillight housing
- Taillight housing bolts directly to Lokar Dial-In Board or can be mounted in a universal location
- Taillight wiring can be hidden in machined slot on Lokar Dial-In Board
- Color and style match Lokar Dial-In Board
- Available in black, polished and clear finish
- Stainless steel mounting hardware
- Long-life LED illuminates to red for safety

### Part No. Description

1110157	Billet Safety LED Taillight - Black (Compatible w/Lokar Dial-in Board)
1110158	Billet Safety LED Taillight - Clear (Compatible w/Lokar Dial-in Board)
1110154	Billet Safety LED Taillight - Polished (Compatible w/Lokar Dial-in Board)



Midnight Series™ Universal Mount



Illuminated



Clear LEDs Illuminate to Red



## 4500/4150 SERIES CARBURETOR ROD TYPE THROTTLE LINKAGE SPRING RETURN KIT

### Features

- Complete with two Stainless Steel Return Springs with dual wound ends for safety (eliminates single hook ends opening up)
- Adjustable spring tensioner
- Throttle Plate also drilled for scoop tray studs
- Scoop tray studs included
- Stainless hardware included
- 4 Hole Plenum style
- Available in Blue, Red or Black finish

### Part No. Description

1010141	4500 Rod Type Throttle Linkage/Spring Return Kit 4 Hole Plenum - Blue
1010142	4500 Rod Type Throttle Linkage/Spring Return Kit 4 Hole Plenum - Red
1010148	4500 Rod Type Throttle Linkage/Spring Return Kit 4 Hole Plenum - Black
1010161	4150 Rod Type Throttle Linkage & Spring Return Kit 4 Hole Plenum - Blue
1010162	4150 Rod Type Throttle Linkage & Spring Return Kit 4 Hole Plenum - Red
1010168	4150 Rod Type Throttle Linkage & Spring Return Kit 4 Hole Plenum - Black



Single Non In-Line Cylinder Shown



## 4500/4150 SERIES CARBURETOR PUSH/PULL THROTTLE CABLE MOUNTING BRACKET & SPRING RETURN KIT

Designed for push/pull style cables using dual cylinder in-line throttle stops or single cylinder in-line throttle stops.

### Features

- Includes two brackets to allow use of many different throttle stop styles
- Complete with two Stainless Steel Return Springs with dual wound ends for safety (eliminates single hook ends opening up)
- Adjustable Angle throttle cable mount for obtaining correct angle, creating less strain on throttle cable
- Adjustable spring tensioner
- When using a throttle stop, design allows cylinders to hang below and remain in-line, eliminating typical top mount "flopping".
- Can function without throttle stop
- Throttle Plate also drilled for scoop tray studs
- Scoop tray studs included
- Stainless hardware included
- 4500 Series available with 4 Hole or Open Plenum
- Available in Blue, Red or Black finish



Double In-Line Shown



Push/Pull Throttle Cable Mounting Bracket & Spring Return Kit Open Plenum

### Part No. Description

1010111	4500 Push/Pull Throttle Cable Mounting Bracket and Spring Return Kit 4 Hole Plenum - Blue
1010112	4500 Push/Pull Throttle Cable Mounting Bracket and Spring Return Kit 4 Hole Plenum - Red
1010118	4500 Push/Pull Throttle Cable Mounting Bracket and Spring Return Kit 4 Hole Plenum - Black
1010121	4500 Push/Pull Throttle Cable Mounting Bracket and Spring Return Kit Open Plenum - Blue
1010122	4500 Push/Pull Throttle Cable Mounting Bracket and Spring Return Kit Open Plenum - Red
1010128	4500 Push/Pull Throttle Cable Mounting Bracket and Spring Return Kit Open Plenum - Black
1010151	4150 Push/Pull Throttle Cable Mounting Bracket & Spring Return Kit 4 Hole Plenum- Blue
1010152	4150 Push/Pull Throttle Cable Mounting Bracket & Spring Return Kit 4 Hole Plenum- Red
1010158	4150 Push/Pull Throttle Cable Mounting Bracket & Spring Return Kit 4 Hole Plenum- Black



## LOKAR WEAR

Demonstrate your support for Lokar products while wearing a T-shirt, Sweatshirt, Logo Shirt or Logo Jacket.

## Silk Screened T-Shirts

Six Color Design Front and Back Logo  
Sizes: S, M, L, XL, XXL, XXXL  
Color: Black

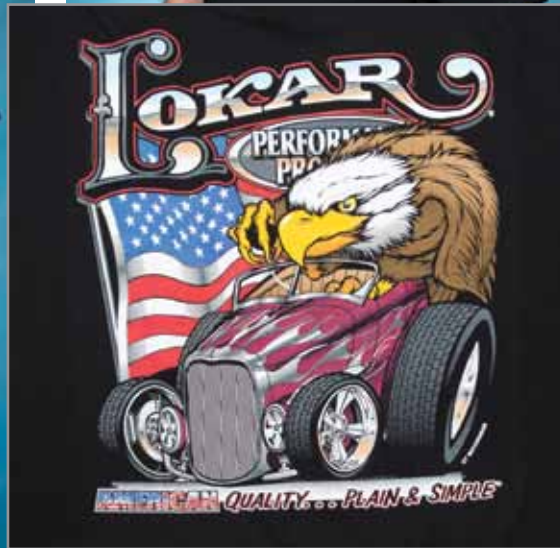

## Lokar Embroidered Logo Jackets

Black wool body/leather sleeve varsity jacket. Full Lokar logo embroidered on back/small logo on front left chest. Fully lined.  
Sizes: L-XL-XXL



### Lokar Logo Sweatshirts

One Color Design Front and Back Logo

Sweatshirt - 50/50 Heavyweight

Sweatshirt Sizes: M-L-XL-2XL-3XL-4XL

Colors: Black only



Back logo

### Lokar Logo Umbrella

- 42" Spring-Loaded with 8 Panels
- Windproof
- Storage case included



### Lokar Embossed Metal Sign

- Measures 14" x 13"
- Great for displaying in your shop or garage