

MILE MARKER



WINCHES



LOCKING HUBS



RECOVERY GEAR



ACCESSORIES

2021 PRODUCT CATALOG



TABLE OF CONTENTS

**2 JEEP/TRUCK/SUV
WINCHES**

**7 TRAILER & UTILITY
WINCHES**

**8 POWERSPORTS
WINCHES**

**11 HYDRAULIC
WINCHES**

**20 MOUNTING
SYSTEMS**

29 RECOVERY GEAR

**31 WINCH
ACCESSORIES**

**34 TRANSFER CASE
CONVERSION KITS**

**35 PREMIUM LOCKING
HUBS**

**36 HUB APPLICATION
GUIDE**

JEEP/TRUCK/SUV WINCHES

SUBMERSIBLE SOLENOID
Marine grade connections at the remote control plug and socket

STAINLESS STEEL
Bolts and fasteners to prevent exterior corrosion even in the smallest places

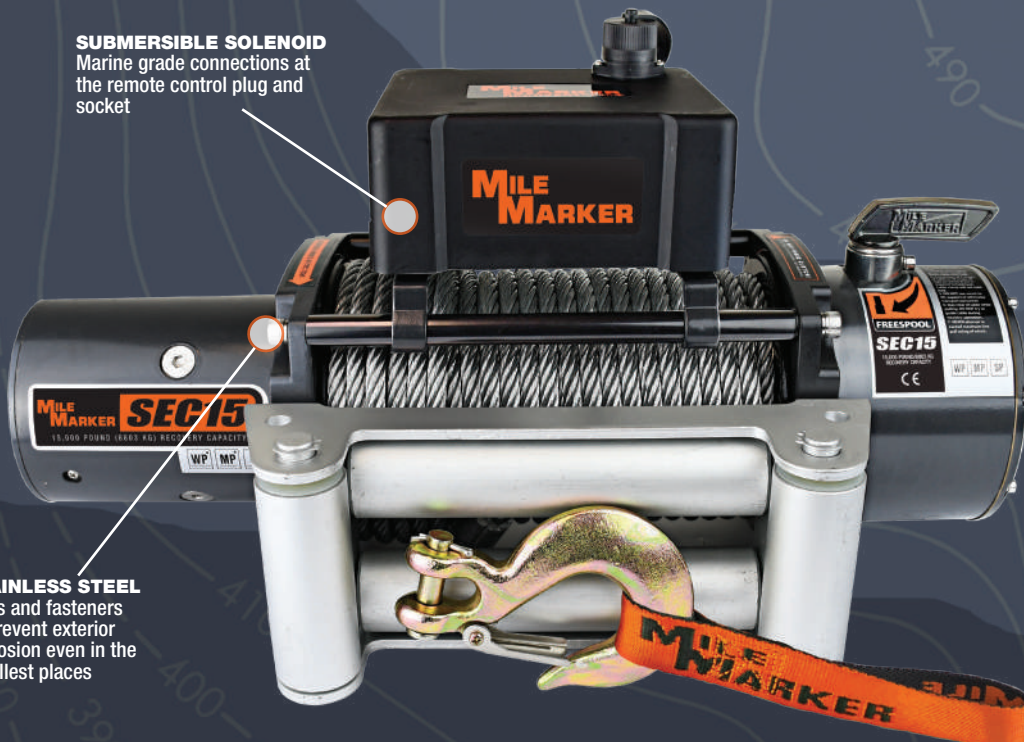

ALL WEATHER WINCHING

Our completely sealed, fully submersible winch is a design that can truly spite the weather. A winch at its core is a tool, waiting for its call to action. Wherever you off-road, our waterproof winches will always be ready to perform. No rusting, no corroding, no pitting.

STRENGTH, PERFORMANCE, VALUE

Mile Marker winches define value – both our working range line speeds and our performance are the best in the class. This comes from years of motor tuning and gear ratio development to ensure high quality performance across the electric winch line.

CHOOSE THE WINCH FOR YOU

We offer 8,000, 9,500, 12,000 and 15,000 pound units for your off-roading truck, Jeep or SUV. Our 18,000 pound winch's innovative design is perfect for your tow truck or industrial DC applications.



WATERPROOF

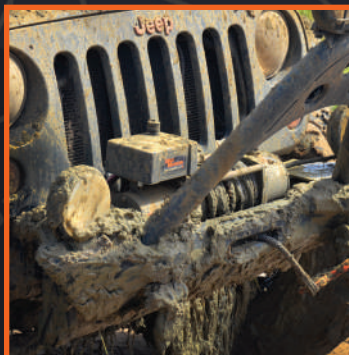

MUD PROOF



SNOW PROOF

SEC18



77-50280W

FEATURES:

- 7.7 HP Series Wound Motor
- Rugged Planetary Gear Sets
- Clockable Gear Housing
- Fast Line Speeds
- Submersible, 400 Amp Solenoid
- Automatic Load Holding Brake
- Corrosion Resistant Stainless Steel Fasteners
- 79' Steel Cable
- Roller Fairlead
- Waterproof
- Handheld Remote Control

STRONGEST ELECTRIC WINCH

The SEC18 pulls 18,000 pounds of recovery power. This industrial grade winch is perfect for your tow truck, fire truck, utility vehicle, or industrial DC. Our SEC18 is lightweight for its strength and features fast line speeds.

SPECIFICATIONS (18K):

Rated Line Pull	18000 lbs. (8164 kg)
Gear Train	3 Stage planetary
Gear Ratio	315:1
Motor	12 Volt DC, input power 7.7 hp (5.6 kw) 24 Volt available
Remote	Power in, Power out with 12' cable (3.7 m)
Dimensions (LxWxH)	26" X 8.5" X 8.5" (662 mm X 214 mm X 214 mm)
Steel Cable	1/2" X 79' (12.7 mm X 24 m) (19,505 lb. breaking strength)
Drum Size Diameter x Length	4" X 10" (101.6 mm X 254 mm)
Flange Diameter	9" (228.6 mm)
Net Weight	154 lb. (69.8 kg)
Bolt Pattern	8 bolt pattern Outer 6.5" X 12" (165 mm X 304.8 mm) Inner 4.5" X 12" (114.3 mm X 304.8 mm)

PERFORMANCE (18K):

Line Pull	Line Speed	Line Speed		Motor Current
		fpm (12V)	mpm (12V)	
lb	kg			amps @ 12 V
0	0	23.6	7.2	68
6000	2724	10.2	3.1	235
8000	3632	9.2	2.8	282
10000	4540	4.9	1.5	310
12000	5448	3.9	1.2	378
15000	6810	3.3	1	420
18000	8172	2.6	0.8	469

SEC15

BIG WINCH POWER, SMALL WINCH WEIGHT

Our 15,000 pound winch packs heavy duty power. The light, compact design mounts easily to a full size truck or Jeep. Each SEC15 includes a 15' recovery strap for longer pulls.



Steel Cable

76-50260W



Synthetic Rope

76-53260W

FEATURES:

- 6.8 HP Series Wound Motor
- Rugged Planetary Gear Sets
- Clockable Gear Housing
- Fast Line Speeds
- Submersible, 400 Amp Solenoid
- Automatic Load Holding Brake
- Corrosion Resistant Stainless Steel Fasteners
- 79' Steel Cable or 72' Synthetic Rope
- Aluminum Hawse or Roller Fairlead
- Waterproof
- Handheld Remote Control
- Includes 15' Recovery Strap

SPECIFICATIONS (15K):

Rated Line Pull	15000 lbs (6803 kgs)
Gear Train	3 Stage planetary
Gear Ratio	294:1
Motor	Series wound, 6.8 hp (5 kw), 12 Volt 24 Volt available
Remote	Power in, Power out with 12' cable (3.7 m)
Dimensions (LxWxH)	22" X 6.3" X 8.3" (558 mm X 160 mm X 211 mm)
Steel Cable	25/64" X 79' (10 mm X 24 m) (16,409 lb. breaking strength)
Synthetic Rope	25/64" X 72' (10 mm X 22 m) (18,078 lb. breaking strength)
Drum Size Diameter x Length	2.9" X 8.9" (75 mm X 226 mm)
Net Weight Synthetic Rope	63 lbs (28.5 kgs)
Net Weight Steel Cable	85 lbs (38.5 kgs)
Bolt Pattern	4 bolt pattern, 4.5" x 10" (114.3 mm X 254 mm)

PERFORMANCE (15K):

Line Pull		Line Speed		Motor Current
lb	kg	fpm	mpm	amps @ 12 V
0	0	16.7	5	120
4000	1816	12	3.7	202
6000	2724	10.5	3.2	225
8000	3632	9.2	2.8	250
10000	4540	7.9	2.4	310
12000	5448	6.6	2	355
15000	6810	5.9	1.8	420



LIGHTEST, MOST COMPACT 15K WINCH IN THE INDUSTRY



INCLUDES 15' RECOVERY STRAP

SEC12 & SEC95

PROVEN WINCH DESIGN, UNMATCHED VALUE

Heavy duty series wound motors and rugged planetary gear sets are the backbone of Mile Marker. With robust controls and a fully sealed solenoid and body, the SEC12 and SEC95 are proven winches at an unmatched value.



*Steel Cable 76-50251BW
Synthetic Rope 76-53251BW



*Steel Cable 76-50246BW
Synthetic Rope 76-53246BW

SPECIFICATIONS (12K):

Rated Line Pull	12000 lbs (5443 kg)
Gear Train	3 Stage planetary
Gear Ratio	294:1
Motor	Series wound, 4.9 hp (3.6 kw), 12 Volt, 24 Volt available
Remote	Power in, Power out with 12' cable (3.7 m)
Dimensions (LxWxH)	20.8" X 6.3" X 7.8" (528 mm X 161 mm X 200 mm)
Steel Cable	3/8" X 100' (9.5 mm X 30.5 m) (14,400 lb. breaking strength)
Synthetic Rope	3/8" X 92' (9.5 mm X 28 m) (18,078 lb. breaking strength)
Drum Size Diameter X Length	2.6" X 8.3" (67 mm X 212 mm)
Net Weight Synthetic Rope	48 lbs (30.3 kg)
Net Weight Steel Cable	67 lbs (41.7 kg)
Bolt Pattern	4 bolt pattern, 4.5" x 10" (114.3 mm X 254 mm)

PERFORMANCE (12K):

Line Pull	Line Speed	Motor Current		
lb	kg	fpm	mpm	amps @ 12 V
0	0	16.4	5	85
4000	1816	8.8	2.7	160
6000	2724	7.5	2.3	191
8000	3632	6.7	2	235
10000	4540	5.6	1.7	270
12000	5448	4.9	1.5	320

SPECIFICATIONS (9.5K):

Rated Line Pull	9500 lbs (4309 kg)
Gear Train	3 Stage planetary
Gear Ratio	210:1
Motor	Series wound, 4.9 hp (3.6 kw), 12 Volt, 24 Volt available
Remote	Power in, Power out with 12' cable (3.7 m)
Dimensions (LxWxH)	20.8" X 6.3" X 7.8" (528 mm X 161 mm X 200 mm)
Steel Cable	3/8" X 100' (9.5 mm X 30.5 m) (14,400 lb. breaking strength)
Synthetic Rope	3/8" X 92' (9.5 mm X 28 m) (18,078 lb. breaking strength)
Drum Size Diameter X Length	2.64" X 8.7" (67 mm X 222mm)
Net Weight Synthetic Rope	48 lbs (30.3 kg)
Net Weight Steel Cable	67 lbs (41.7 kg)
Bolt Pattern	4 bolt pattern, 4.5" x 10" (114.3 mm X 254 mm)

PERFORMANCE (9.5K):

Line Pull	Line Speed	Motor Current		
lb	kg	fpm	mpm	amps @ 12 V
0	0	21	6.4	86
2000	908	11	3.4	150
4000	1816	8.8	2.7	205
6000	2724	7.5	2.3	235
8000	3632	6	1.8	252
9500	4313	4.3	1.3	330

FEATURES:

- 4.9 HP Series Wound Motor
- Rugged Planetary Gear Sets
- Clockable Gear Housing
- Fast Line Speeds
- Submersible, 400 Amp Solenoid
- Automatic Load Holding Brake
- Corrosion Resistant Stainless Steel Fasteners
- 100' Steel Cable or 92' Synthetic Rope
- Aluminum Hawse or Roller Fairlead
- Waterproof
- Handheld Remote Control

SEC8

WORKING RANGE PERFORMANCE

The SEC8 is light and affordable for the standard off road vehicle. With robust controls and a fully sealed solenoid and body, Mile Marker redefines performance in the 8,000 pound winch class.



Steel Cable

77-50141W



Synthetic Rope

77-53141W

SPECIFICATIONS (8K):

Rated Line Pull	8000 lbs (3629 kg)
Gear Train	3 Stage planetary
Gear Ratio	150:1
Motor	Series wound, 4.9 hp (3.6 kw), 12 V 24 Volt available
Remote	Power in, Power out with 12' cable (3.7 m)
Dimensions (LxWxH)	20.8" X 6.3" X 7.8" (528 mm X 161 mm X 200 mm)
Steel Cable	5/16" X 100' (7.9 mm X 30.5 m) (9,800 lb. breaking strength)
Synthetic Rope	5/16" X 92' (7.9 mm X 28 m) (13,228 lb. breaking strength)
Drum Size Diameter X length	2.5" X 8.3" (63 mm X 222 mm)
Net Weight Synthetic Rope	49 lbs (37 kg)
Net Weight Steel Cable	63 lbs (31.7 kg)
Bolt Pattern	4 bolt pattern, 4.5" x 10" (114.3 mm X 254 mm)

FEATURES:

- 4.9 HP Series Wound Motor
- Rugged Planetary Gear Sets
- Clockable Gear Housing
- Fast Line Speeds
- Submersible, 400 Amp Solenoid
- Automatic Load Holding Brake
- Corrosion Resistant Stainless Steel Fasteners
- 100' Steel Cable or 92' Synthetic Rope
- Aluminum Hawse or Roller Fairlead
- Waterproof
- Handheld Remote Control

PERFORMANCE: (8K)

Line Pull		Line Speed		Motor Current
lb	kg	fpm	mpm	amps @ 12 V
0	0	38.1	11.6	70
2000	908	14.1	4.3	136
4000	1816	12.5	3.8	198
6000	2724	9.8	3	264
8000	3632	8.2	2.5	284



TRAILER & UTILITY WINCHES

COMPACT SIZE, POWERFUL PULL

The SEC4500 defines fast line speeds and low amperage draw for your large side by side or UTV. The 2000 lb. utility winches features a wireless remote control and a high output motor.



76-50115BW

FEATURES (4.5K):

- 3.7 HP Series Wound Motor
- Rugged Planetary Gear Sets
- Clockable Gear Housing
- Fast Line Speeds
- Submersible, 250 Amp Solenoid
- Automatic Load Holding Brake
- Corrosion Resistant Stainless Steel Fasteners
- 79' Steel Cable
- Roller Fairlead
- Waterproof
- Handheld Remote Control
- Includes Tow Strap
- Includes Mounting Plate

SPECIFICATIONS (4.5K):

Rated Line Pull	4500 lbs (2041 kg)
Gear Train	3 Stage planetary
Gear Ratio	150:1
Motor	12 Volt DC, input power 3.7hp (2.7 kw) 24 Volt available
Remote	Power in, Power out with 12' cable (3.7 m)
Dimensions (LxWxH)	17.3" X 6.3" X 7.8" (440 mm X 161 mm X 200 mm)
Steel Cable	1/4" X 79' (6.3 mm X 24 m) (7,000 lb. breaking strength)
Drum Size Diameter X Length	2.5" X 5.5" (63 mm X 140 mm)
Net Weight Steel Cable	49 lbs (23 kg) (with mounting plate)
Bolt Pattern	4 bolt pattern 6.5" X 4.5" (165.9 mm X 114.3 mm)

PERFORMANCE (4.5K):

Line Pull	Line Speed	Motor Current		
lb	kg	fpm	mpm	amps @ 12 V
0	0	38.1	11.6	70
1500	681	17.1	5.2	125
3000	1362	14.1	4.3	160
4500	2043	11.8	3.6	205



76-50200

FEATURES (2K):

- High Output Motor
- Automatic Load Holding Dynamic Brake
- Fast Line Speeds
- 50' Steel Cable
- Roller Fairlead
- All Metal Planetary Gearing
- Free Spooling
- Wireless Remote Control

SPECIFICATIONS (2K):

Rated Line Pull	2000 lbs (907 kg)
Gear Train	2 Stage planetary
Gear Ratio	163:1
Motor	Permanent Magnet 12 Volt 1.9 hp (1.4 kw)
Remote	Wireless remote control
Dimensions (LxWxH)	11.2" X 4.5" X 4.2" (285.5 mm X 113 mm X 107.5 mm)
Steel Cable	5/32" X 50' (4 mm X 15.2 m)
Drum Size Diameter X Length	1.2" X 2.8" (32 mm X 72 mm)
Net Weight	16 lb. (7.2 kg)
Bolt Pattern	2 bolt pattern 1.8" X 3" (48 mm X 76 mm)

PERFORMANCE (2K):

Line Pull	Line Speed	Motor Current		
lb	kg	fpm	mpm	amps @ 12 V
0	0	14.0	4.3	14
1000	454	9.0	2.7	60
1500	680	7.5	2.3	90
2000	908	5.9	1.8	115

POWERSPORTS WINCHES

WATERPROOF

Marine grade connectors at the control and solenoid



HIGH OUTPUT MOTOR

These winches pack enough punch to take on the most daunting task

COMPACT POWER

The Mile Marker Powersports winch line packs powerful recovery into a rugged, compact size. Your ATV or UTV can always rely on our planetary gear systems and high output motor for your most daunting off road pulls. No weather worries with completely sealed units to the IP68 Standard.

CHOOSE THE WINCH FOR YOU

We offer 5000, 3500, or 2500 pound winches to best suit your vehicle. Equipped with synthetic rope or steel cable.



FASTEST, MOST POWERFUL



RUGGED COMPACT SIZE



COMPLETELY ELEMENT SEALED

PE5000

PACK THE POWER

The PE5000 slams raw power into a lightweight, compact design for your ATV/UTV. Metal planetary gear systems and a fully waterproof solenoid lets you winch wherever you ride.



Steel Cable

77-50120W



Synthetic Rope

77-53120W

SPECIFICATIONS (5K):

Rated Line Pull	5000 lbs (2267.9 kg)
Gear Train	3 Stage planetary
Gear Ratio	165:1
Motor	12 Volt DC, input power 3.8hp 24 Volt available
Remote	Power in, Power out with 12' cable (3.7 m)
Winch Dimensions (LxWxH)	15.6" X 4.6" X 4.7" (397 mm X 117 mm X 119.8 mm)
Steel Cable	1/4" X 79' (6.3 mm X 24 m) (5,600 lb. breaking strength)
Synthetic Rope	1/4" X 50' (6.3 mm X 15.2 m) (5,071 lb. breaking strength)
Drum Size Diameter X Length	2" X 5.4" (51 mm X 137.5 mm)
Net Weight Synthetic Rope	19.5 lbs (8.6 kg)
Net Weight Steel Cable	23.7 lbs (10.8 kg)
Bolt Pattern	4 bolt pattern 3" X 6.6" (76 mm X 168 mm)

FEATURES:

- 3.8 HP Permanent Magnet Motor
- All Metal Planetary Gearing
- Submersible, 250 Amp Solenoid
- Automatic Load Holding Brake
- Center Focused Drum
- Fast Line Speeds
- 79' Steel Cable or 50' Synthetic Rope
- Aluminum Hawse or Roller Fairlead
- Waterproof
- Handheld Remote Control

PERFORMANCE (5K):

Line Pull		Line Speed 12V		Motor Current 12V
lbs	kgs	fpm	mpm	amp
0	0	20.7	6.3	34
2000	908	15.1	4.6	135
3000	1362	11.5	4	155
4000	1816	10.5	3.2	210
5000	2270	9.2	2.8	250



PE3.5 & PE2.5



PE3.5 Steel Cable

77-50112BW



PE3.5 Synthetic Rope

77-53112BW



PE2.5 Steel Cable

77-50105BW

FEATURES:

- 2.4 HP Permanent Magnet Motor
- All Metal Planetary Gearing
- Submersible, 200 Amp Solenoid
- Automatic Load Holding Brake
- Center Focused Drum
- Fast Line Speeds
- 42' Steel Cable or 50' Synthetic Rope
- Aluminum Hawse or Roller Fairlead
- Waterproof
- Handheld and Handlebar Controls

SPECIFICATIONS:

Rated Line Pull	PE3.5	3500 lbs (1589 kg)
Rated Line Pull	PE2.5	2500 lbs (1135 kg)
Gear Train	All	2 Stage planetary
Gear Ratio	ALL	242:1
Motor	PE3.5	2.4 hp (1.8 kw), 12 V DC
Motor	PE2.5	2.4 hp (1.8 kw)
Remote	All	Power in, Power out with 12' cable (3.7 m)
Dimensions (LxWxH)	PE3.5	13.5" X 4.5" X 4.3" (344 mm X 116 mm X 108 mm)
Dimensions (LxWxH)	PE2.5	13.2" X 4.6" X 4.3" (334 mm X 116 mm X 108 mm)
Steel Cable	PE3.5	7/32" X 42' (5.5 mm X 12.7 m) (5,600 lb. breaking strength)
Steel Cable	PE2.5	3/16" X 42' (4.7 mm X 12.7 m) (5,600 lb. breaking strength)
Synthetic Rope	PE3.5	7/32" X 50' (5.5 mm X 15.2 m) (5,071 lb. breaking strength)
Drum Size Diameter X Length	ALL	2" X 3.1" (50 mm X 80 mm)
Net Weight Steel Cable	PE3.5	17.3 lbs (7.8 kg)
Net Weight Steel Cable	PE2.5	15.1 lbs (6.8 kg)
Net Weight Synthetic rope	PE3.5	14.3 lbs (6.4 kg)
Bolt Pattern	All	4 Bolt pattern, 4.8" X 3" (124 mm X 76 mm)

PERFORMANCE: PE3.5

Line Pull	Line Speed	Motor Current		
lb	kg	fpm	mpm	amps @ 12 V
0	0	18	5.5	22
1000	454	14.8	4.5	82
2000	908	12.5	3.8	145
3000	1362	10.8	3.3	225
3500	1589	9.8	3	250

PERFORMANCE: PE2.5

Line Pull	Line Speed	Motor Current		
lb	kg	fpm	mpm	amps @ 12 V
0	0	23	7	35
1000	454	18	5.5	100
1500	681	16	4.8	128
2000	908	14	4.2	150
2500	1135	12	3.6	190

HYDRAULIC WINCHES

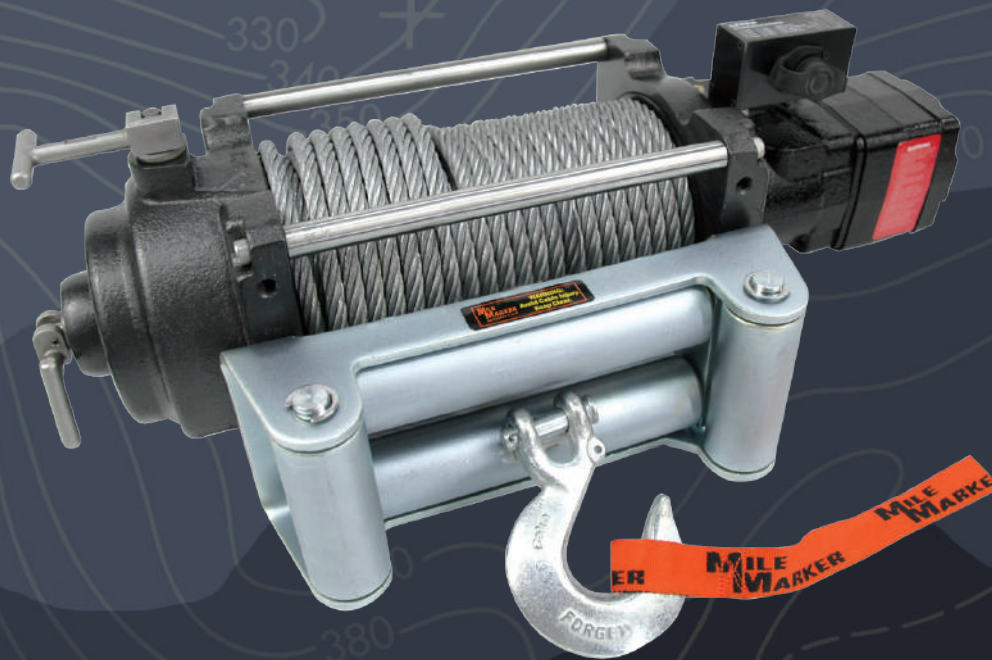

LEGENDARY POWER

The serious off roaders dream winch, Mile Marker hydraulics utilize the power steering pump as the power source instead of a battery. The result? Continuous winching. Quality winching. Uninterrupted winching. Legendary power.

CHOOSE THE WINCH FOR YOU

The H and HI series winches run off the power steering of standard vehicles. Choose among 9,000, 10,500 and 12,000 pound capacity winches. For other applications, see our low pressure winch, tow truck winch, and 18K heavy duty and wrecker winch.

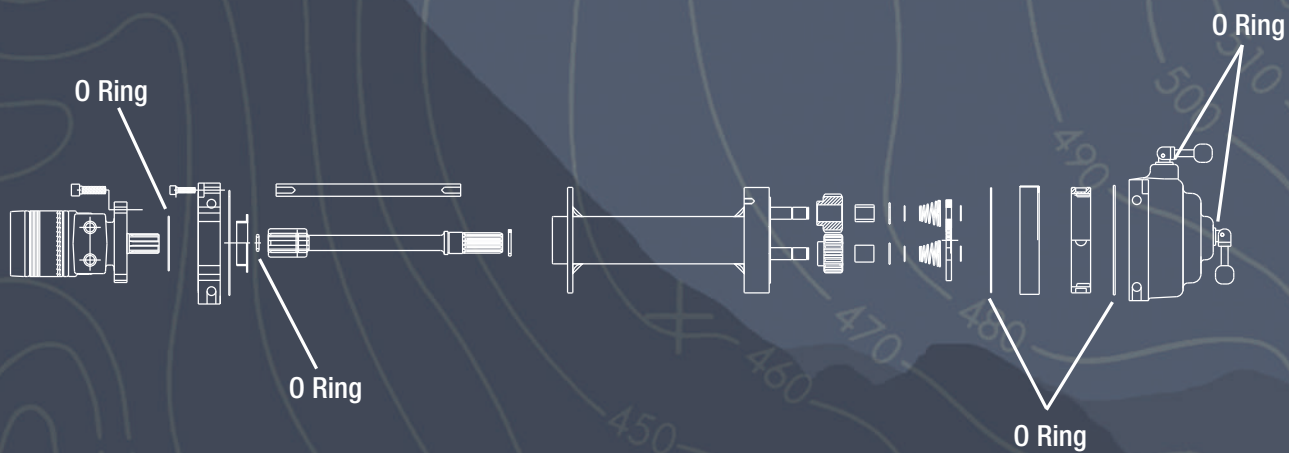

CONSTRUCTION

Internally sealed winches with O rings in every critical spot make all our hydraulics completely element proof. Six seals keep any contaminants outside. Using the relief valve as a built in governor, it is impossible to overload or overwork the pump of your vehicle's power steering, the source of the winch's legendary power.

INSTALLATION

Vehicle specific adapter kits are required for most applications to connect the winch to the pump (see page 17)



34 SERIES



35 SERIES



BUILT TO LAST



CONTINUOUS USE



ELEMENT PROOF

H SERIES

Mile Marker's H Series hydraulics mount to either the front or the rear of the vehicle as a permanent or detachable winch. The system is independent from its solenoid control valve to allow for these mounting options. Most applications require a 34 series kit to fit the winch to your vehicle. The kit includes important components for installation.

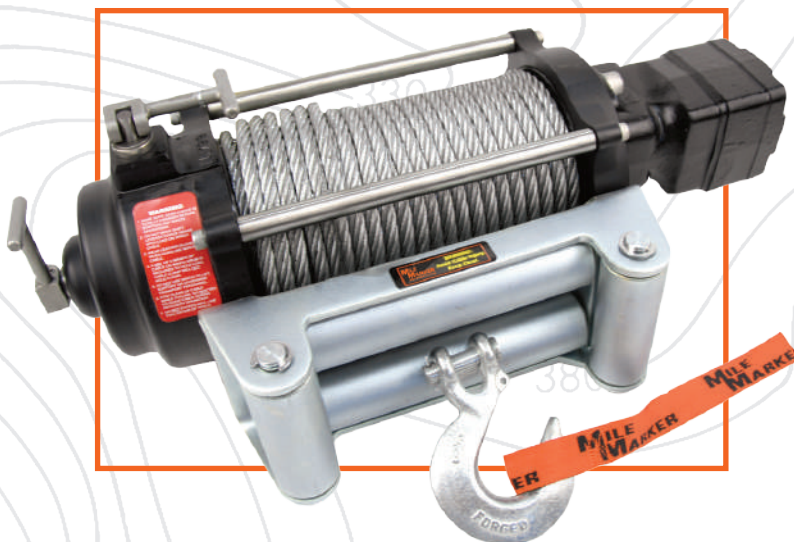

H9000

9,000 LB (4082 kg)
70-50080C

H10500

10,500 LB (4763 kg)
70-50050C

H12000

12,000 LB (5443 kg)
70-52000C

FEATURES:

- 100% Duty Cycle
- 2 Speed
- Power Steering Pump Powered
- Submersible
- Stainless Steel Tie Bars and Fasteners
- Ductile Iron Body (H12000 Only)
- Reversible Mounting (H9000 & H10500 Only)
- 3 Mounting Positions (H12000 Only)
- Mechanical Lock
- Corrosion Resistant
- 100' Steel Cable
- Roller Fairlead
- Free Spooling

SPECIFICATIONS:

Gear Train	Planetary
Gear Ratio	6:1
Motor	9k: 14 cubic inch; 10.5k: 17.9 cubic inch; 12k: 19.5 cubic inch 24V available
Remote	Not included
Steel Cable	3/8" X 100' (9.5 mm X 30.5 m)
Dimensions (LxWxH)	22.5" X 6.5" X 7.8" (571.5 mm X 165.1 mm X 198.1 mm)
Drum Size Diameter X Length	2.5" X 9" (63.5 mm X 228.6 mm)
Power Steering Min. Requirements	3.5 GPM @ 1500 psi (13.2 l/min @ 103.4 bars)
Net Weight	H9000/H10500: 93 lbs (42.2 kgs) H12000: 101 lbs (45.8 kgs)
Bolt Pattern	4 bolt pattern, 4.5" X 10" (114.3 mm X 254 mm)

PERFORMANCE:

9000

3.5 GPM @ 1500 PSI (13.25 L/m @ 103.4 bars)				
Layer of Cable	1	2	3	4
Line speed - low gear (FPM)	6.1	7.4	8.8	10.5
Rated pull (lbs.)	9,000	7,300	6,200	5,400
Line speed - high gear (FPM)	33.6	38.4	48	57
Rated pull (lbs.)	1,500	1,200	1,000	900

10500

3.5 GPM @ 1500 PSI (13.25 L/m @ 103.4 bars)				
Layer of Cable	1	2	3	4
Line speed - low gear (FPM)	5.6	6.4	7.4	8.5
Rated pull (lbs.)	10,500	8,500	7,400	6,400
Line speed - high gear (FPM)	31	36	42	48
Rated pull (lbs.)	1,600	1,300	1,200	1,000

12000

3.5 GPM @ 1500 PSI (13.25 L/m @ 103.4 bars)				
Layer of Cable	1	2	3	4
Line speed - low gear (FPM)	5.6	6.4	7.4	8.5
Rated pull (lbs.)	12,000	9,400	8,200	7,000
Line speed - high gear (FPM)	31	36	42	48
Rated pull (lbs.)	2,000	1,550	1,350	1,150



34 SERIES ADAPTER KIT MAY BE REQUIRED
SEE APPLICATION CHART ON PAGE 17

HI SERIES

The Mile Marker HI Series hydraulic winch is designed for permanent mounting on the front of your vehicle. The solenoid control valve is integrated into the winch. A 35 Series adapter kit is needed to adapt to your power steering system.

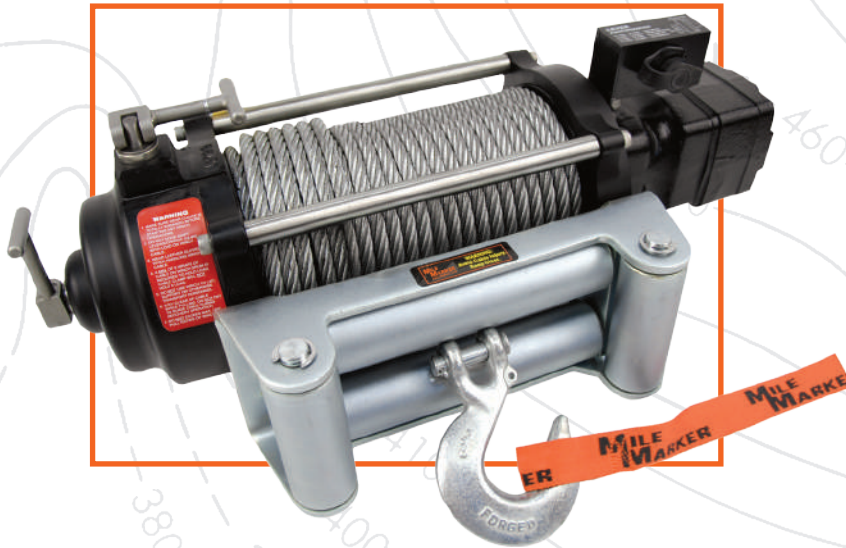

HI9000

9,000 LB (4082 kg)
75-50085C

HI10500

10,500 LB (4763 kg)
75-50050C

HI12000

12,000 LB (5443 kg)
75-52000C

FEATURES:

- 100% Duty Cycle
- 2 Speed
- Power Steering Pump Powered
- Submersible
- Stainless Steel Tie Bars and Fasteners
- Ductile Iron Body (HI12000 Only)
- Reversible Mounting (HI9000 & HI10500 Only)
- 3 Mounting Positions (HI12000 Only)
- Mechanical Lock
- Corrosion Resistant
- 100' Steel Cable
- Roller Fairlead
- Free Spooling
- Handheld Remote Control

SPECIFICATIONS:

Gear Train:	Planetary
Gear Ratio	6:1
Motor	9k: 14 cubic inch; 10.5k: 17.9 cubic inch; 12k: 19.5 cubic inch 24V available
Remote	Not included
Steel Cable	3/8" X 100' (9.5 mm X 30.5 m)
Dimensions	21.9" X 7.8" HI9000 22.1" X 7.8" HI10500 22.5" X 7.8" HI12000
Drum Size Diameter X Length	2.5" X 9" (63.5 mm X 228.6 mm)
Power Steering Min. Requirements	3.5 GPM @ 1500 psi (13.2 l/min @ 103.4 bars)
Net weight	HI9000/HI10500: 103 lbs (47 kgs) HI12000: 110 lbs (50 kgs)
Bolt Pattern	4 bolt pattern, 4.5" X 10" (114.3 mm X 254 mm)

PERFORMANCE:

9000

3.5 GPM @ 1500 PSI (13.25 L/m @ 103.4)				
Layer of Cable	1	2	3	4
Line speed - low gear (FPM)	6.1	7.4	8.8	10.5
Rated pull (lbs.)	9,000	7,300	6,200	5,400
Line speed - high gear (FPM)	33.6	38.4	48	57
Rated pull (lbs.)	1,500	1,200	1,000	900

10500

3.5 GPM @ 1500 PSI (13.25 L/m @ 103.4)				
Layer of Cable	1	2	3	4
Line speed - low gear (FPM)	5.6	6.4	7.4	8.5
Rated pull (lbs.)	10,500	8,500	7,400	6,400
Line speed - high gear (FPM)	31	36	42	48
Rated pull (lbs.)	1,600	1,300	1,200	1,000

12000

3.5 GPM @ 1500 PSI (13.25 L/m @ 103.4)				
Layer of Cable	1	2	3	4
Line speed - low gear (FPM)	5.6	6.4	7.4	8.5
Rated pull (lbs.)	12,000	9,400	8,200	7,000
Line speed - high gear (FPM)	31	36	42	48
Rated pull (lbs.)	2,000	1,550	1,350	1,150



35 SERIES ADAPTER KIT IS REQUIRED
SEE APPLICATION CHART ON PAGE 17

18K ONE SPEED HYDRAULIC WINCH

Our most powerful hydraulic winch, the 18K winch is designed for heavy duty, commercial, utility and wrecker applications.

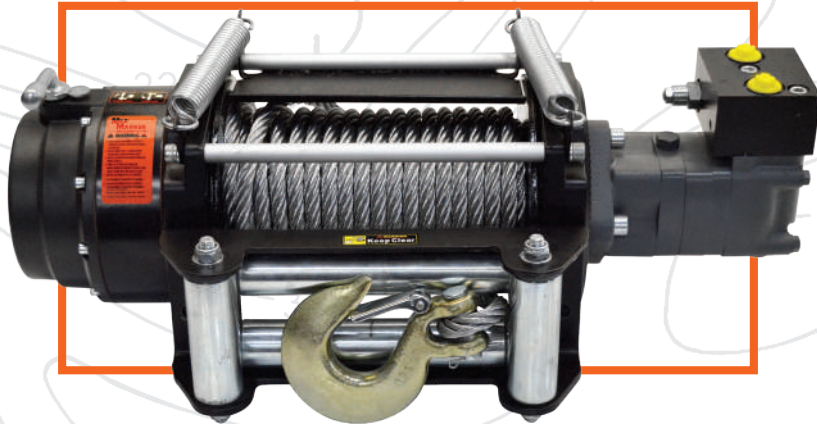

70-58010C

SPECIFICATIONS:

Gear Train	Planetary, hardened steel gear
Gear Ratio	36:01
Motor	7.6 cubic inch (124.5 cubic centimeters)
Remote	Not included
Dimensions (LxWxH)	25.8" X 8.4" X 9.6" (656 mm X 214 mm X 245 mm)
Steel Cable	1/2" X 75' (12.7 mm 22 m) Nominal breaking strength = 26,600 lbs
Drum Size Diameter X Length	4" X 9.9" (102 mm x 253 mm)
Net Weight	158.7 lbs (72 kgs)
Bolt Pattern	8 bolt pattern Outer 6.5" X 12" (165 mm X 304.8 mm) Inner 4.5" X 12" (114.3 mm X 304.8 mm)

FEATURES:

- Automatic Load Holding Brake
- Heavy Duty Engagement Clutch
- Submersible
- Stainless Steel Tie Bars and Fasteners
- Mechanical Lock
- Corrosion Resistant
- 75' Steel Cable
- Roller Fairlead
- Free Spooling

PERFORMANCE:

High Speed Performance Specification (max 2030 PSI or 140BAR) (max 103.4 bars)

LAYER	Rated Line Pull		Line Speed				Cable Capacity	
			At 15 GPM (56.8.1 L/m)		At 20 GPM (75.71 L/m)			
	lbs	kgs	fpm	mpm	fpm	mpm	ft	m
1	18000	8165	14.9	4.5	17.4	5.3	21	6.4
2	14727	6680	18.2	5.5	21.3	6.5	46	14
3	12461	5652	21.5	6.6	25.6	7.8	75	22.9

First Layer Performance

Line Load	Pressure drop at 15 GPM (56.8.1 L/m)	Pressure drop at 20 GPM (75.71 L/m)	
		psi	bar
lbs	kgs	psi	bar
0	0	113	7.8
3000	1361	345	23.8
6000	2722	599	41.3
9000	4082	867	59.8
12000	5443	1137	78.4
15000	6804	1446	99.7
18000	8165	1617	11.5

LOW PRESSURE WINCH

Jeeps, mid sized trucks and sport utility vehicles – we designed a winch for you. If your vehicle produces less than 1500 PSI, you can still harness the legendary power of the Mile Marker hydraulic winch without upgrading the power steering equipment. The low pressure winch will pull 9,100 pounds at 1100 PSI.

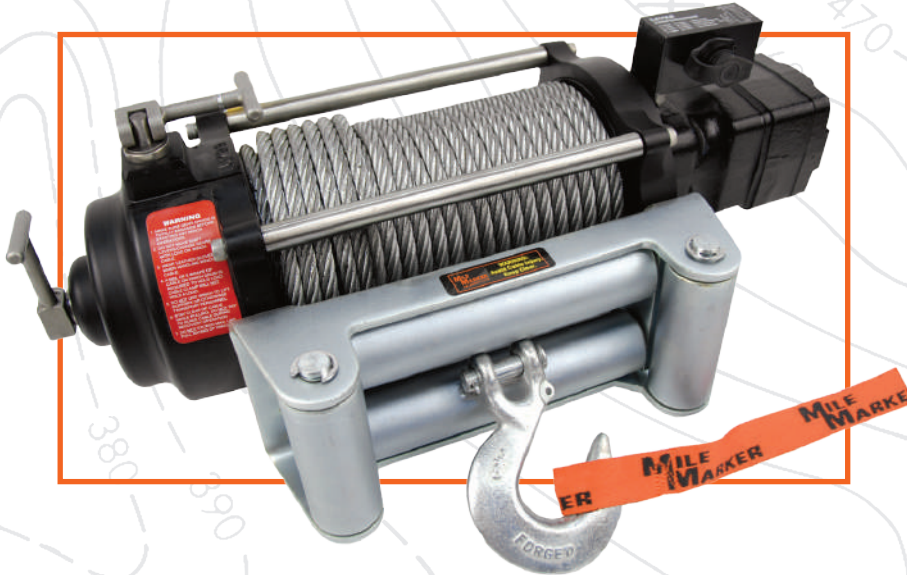

75-50058C

FEATURES:

- 2 Speed
- Integrated Solenoid Valve
- Submersible
- Stainless Steel Tie Bars and Fasteners
- Mechanical Lock
- Corrosion Resistant
- 100' Steel Cable
- Roller Fairlead
- Freespooling
- Handheld Remote Control

SPECIFICATIONS:

Gear Train	Planetary
Gear Ratio	6:1
Motor	19.5 cubic inch
Remote	Illuminated joystick remote, 12'
Steel Cable	3/8" X 100' (nominal 14,400 lbs) (9.5 mm X 30.5 m)
Drum Size: Diameter X Length	2.5" X 9" (63.5 mm X 228.6 mm)
Net Weight	103 lbs (47 kgs)
Bolt Pattern	4 bolt pattern, 4.5" X 10" (114.3 mm X 254 mm)

PERFORMANCE:

LAYER	LOAD	PSI	GPM
1	6700	900	3
1	7800	1000	3
1	9100	1100	3
1	10100	1200	3
1	11000	1300	3
1	12000	1400	3



35 SERIES ADAPTER KIT IS REQUIRED
SEE APPLICATION CHART ON PAGE 17

VEHICLE ADAPTER & VALVE KITS APPLICATION CHART

34 KIT FOR H SERIES WINCHES

REMOTE SOLENOID VALVE

Includes: Remote control with 12' lead, all hoses and fittings, remote solenoid activated control valve, adapter kit for power steering pump (vehicle specific). Rated 7 gpm.

PART NUMBER:	APPLICATION:
AM GENERAL	
34-5010-17	Valve Kit - H1 (civilian)
CHEVY/GMC/H2	
34-5020-14	Valve Kit - '72-'87 GM C/K, '88-'91 RV Series
34-5010-15	Valve Kit - '88-'98 GM C/K, '99 Tahoe/Suburban Silverado, H2
34-5020-16	Valve Kit - '12-'16 GM 2500 & 3500 HD
34-5010-13	Valve Kit - GM S Series with 4.3L Vortec
DODGE	
34-5020-22	Valve Kit - Dodge Dakota 6 & 8 cylinder
34-5010-20	Valve Kit - Dodge Dakota 4 cylinder
34-5020-23	Valve Kit - '72-'93 Dodge Full Size
34-5020-24	Valve Kit - '94 Dodge Full Size
FORD	
34-5010-09	Valve Kit - '97 Ford F-150 Expedition
34-5020-35	Valve Kit - '05 Ford F-250/F-350/F-450/F-550 Excursion
34-5020-37	Valve Kit - '11 Ford F-250/F-350/F-450/F-550 Excursion
34-5010-34	Valve Kit - '99-'04 Ford F-250/F-350/F-450/F-550 Excursion
34-5020-06	Valve Kit - '72-'77 Ford Full Size
34-5020-07	Valve Kit - '78-'96 Ford Full Size, '97-'98 F-250 & F-350
34-5010-07H	Valve Kit - '78-'98 Ford Full Size (with hydro boost)
34-5020-04	Valve Kit - '83-'92 Ford Ranger, '90-'94 Explorer
34-5020-05	Valve Kit - '93-'96 Ford Ranger, '95-'96 Explorer
34-5020-10	Valve Kit - '02 Ford Ranger/Sport Trac
34-5020-38	Valve Kit - Ford '12 Super Duty
34-5020-38H	Valve Kit - Ford '12 Super Duty with hydro boost
INTERNATIONAL	
34-5010-18	Valve Kit - International Truck & Scout
JEEP	
34-5010-50	Valve Kit - Jeep Cherokee
34-5020-51	Valve Kit - Jeep CJ Scrambler
34-5020-55	Valve Kit - Jeep YJ, TJ, JK & Rubicon
LAND ROVER	
34-5010-45	Valve Kit - Land Rover Discovery
NISSAN	
34-5010-30	Valve Kit - '86-'93 Nissan (except Pathfinder)
34-5010-31	Valve Kit - '91-'95 Nissan Pathfinder, '94-'96 Truck
TOYOTA	
34-5020-41	Valve Kit - '79-'02 Toyota
MEDIUM DUTY TRUCKS	
34-5010-80	Valve Kit - (Comes with size 8 hose, pressure relief)

35 KIT FOR HI SERIES WINCHES

INTEGRATED SOLENOID VALVE

Adapts power steering pump to HI Series winches. Includes vehicle specific power steering pump fittings and adapters.

PART NUMBER:	APPLICATION:
35-5020-17	Adapter Kit - AM General Hummer H1
35-5020-81	Adapter Kit - Chevy 5500
35-5020-16	Adapter Kit - '12 GM 2500 & 3500 HD
35-5020-15	Adapter Kit - GM Dodge International Chevrolet H2
35-5020-22	Adapter Kit - '03 & up Durango
35-5020-07	Adapter Kit - Ford up to '98
35-5020-34	Adapter Kit - '97-'04 Ford F-150, '99-'04 Ford
35-5020-10	Adapter Kit - Ford Sport Track Ford Ranger
35-5020-51	Adapter Kit - Jeep
35-5020-45	Adapter Kit - Land Rover
35-5020-31	Adapter Kit - Nissan
35-5020-41	Adapter Kit - Toyota
35-5020-38H	Adapter Kit - '12 Ford Super Duty with hydro boost
35-5020-38	Adapter Kit - '12 Ford Super Duty
35-5020-37	Adapter Kit - '11 Ford Super Duty
35-5020-35	Adapter Kit - '05-'10 Ford Super Duty
35-5020-36	Adapter Kit - '07 Ford F-550 only



34 KIT

VEHICLE SPECIFIC APPLICATIONS



35 KIT

VEHICLE SPECIFIC APPLICATIONS

TOW WINCH

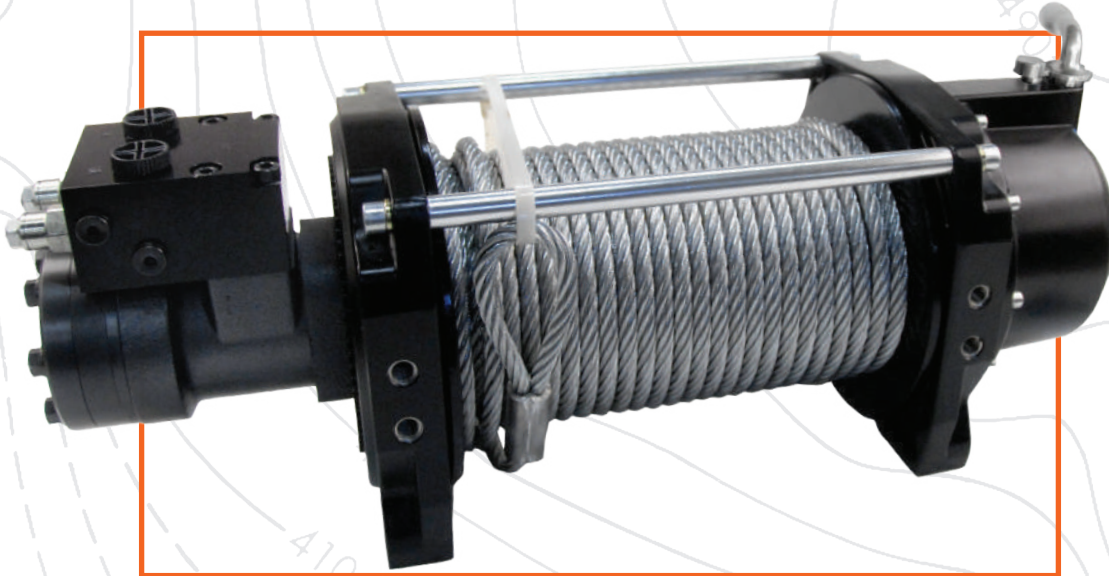

HS9000

70-59000C

SPECIFICATIONS:

Gear Train Planetary, hardened steel gear

Gear Ratio 27:1

Motor 4.9 cubic inches
(80.6 cubic centimeters)

Dimensions (LxWxH) 23.6" X 8.4" X 9.2"
(600 mm X 214 mm X 235 mm)

Steel Cable 3/8" X 100' (9.5 mm X 30.5 m)
(14,400 breaking strength)

Drum Size Diameter/Length 4" X 9.9" (102 mm X 253 mm)

Net Weight 78 lbs

Bolt Pattern 8 bolt pattern
Outer 6.5" X 12" (165 mm X 304.8 mm)
Inner 4.5" X 12" (114.3 mm X 304.8 mm)

Duty Cycle Intermittent per SAE J706 section 6.2
565' (172 m)

FEATURES:

- Automatic Load Holding Brake
- Heavy Duty Engagement Clutch
- Submersible
- Mechanical Lock
- Corrosion Resistant
- Clockwise & Counter Clockwise Rotation
- Cable Tension Plate Sold Separately
- Clutch Kits Sold Separately
- Free Spooling

PERFORMANCE:

Line Pull	Line Speed				
	lb	kg	fpm	mpm	flow L/m
0	0	27.3	8.3	59	
4000	2270	25.5	7.8	56.3	
8000	4086	26.2	8	56.2	
9000	5448	26.2	8	55.6	

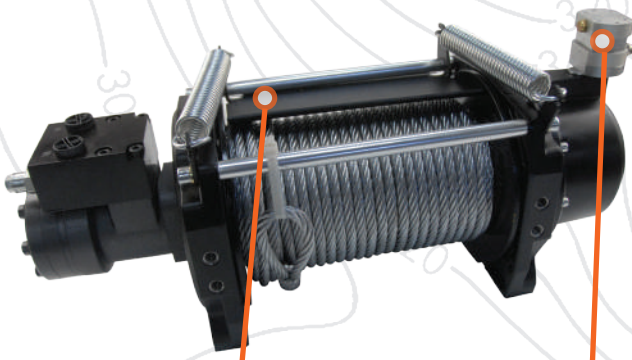

Winch Cable Tension Plate

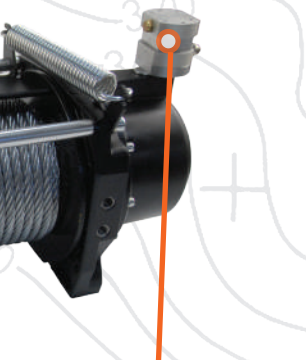

Remote Pneumatic Clutch Kit

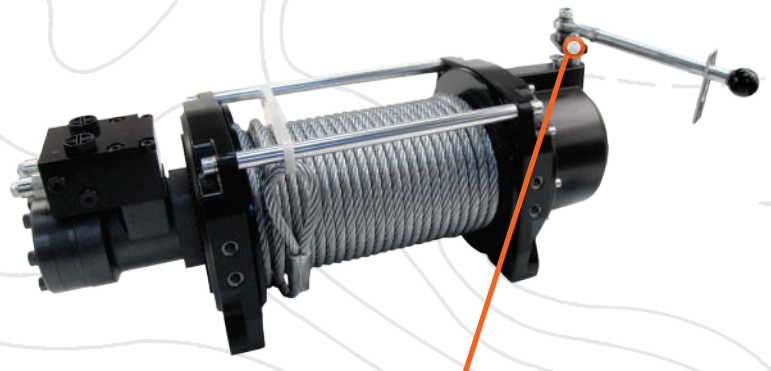

Remote Manual Clutch Kit

Winch Cable Tension Plate: 70591
Remote Pneumatic Clutch Kit: 70593
Remote Manual Clutch Kit: 70592

MOUNTING SYSTEMS

ATV/UTV MOUNTS

The high quality choice for ATV and UTV winch mounts. Heavy duty steel construction and powder coating finishes enhance durability for these made to order custom mounts.



ATV/UTV MOUNT APPLICATION GUIDE

Make	Part Number	Year	Model
ARCTIC CAT ATV			
Arctic Cat	51-1005	'96-'00	500 4x4
Arctic Cat	51-1005	'96-'01	400 2x4, 4x4
Arctic Cat	51-1005	'96-'02	500i
Arctic Cat	51-1005	'98	454 2x4 / 4x4
Arctic Cat	51-1005	'98-'01	300 2x4, 4x4
Arctic Cat	51-1005	'99-'05	250 2x4, 4x4
Arctic Cat	51-1005	'00-'02	500 AUTO
Arctic Cat	51-1005	'01	500 4x4
Arctic Cat	51-1005	'05	300 2x4, 4x4
Arctic Cat	51-1010	'02-'04	300 2x4, 4x4
Arctic Cat	51-1010	'02-'05	400 2X4, 4X4 (ACT) (i)
Arctic Cat	51-1010	'03-'08	400 Automatic 2x4, 4x4 (LE)
Arctic Cat	51-1012	'08-'09	366 4x4
Arctic Cat	51-1015	'06-'16	700 4x4 (Auto) (Auto EFI) (M4) (H1 SE)
Arctic Cat	51-1015	'06-'16	700 Diesel
Arctic Cat	51-1015	'06-'16	700 Mud Pro
Arctic Cat	51-1015	'09-'14	550 4x4
Arctic Cat	51-1015	'10-'12	450 4X4
ARCTIC CAT UTV			
Arctic Cat	51-1860	'06-'09	650 Prowler H1 XT 4X4
Arctic Cat	51-1860	'08-'14	700 Prowler (XTX)
Arctic Cat	51-1860	'09-'14	550 Prowler (XT)
Arctic Cat	51-1860	'10-'14	1000 Prowler XTZ 4X4
Arctic Cat	51-1878	'20	Prowler Pro Crew
ARGO ATV			
Argo ATV	51-1180	'18	500 Xplorer XR (LE)
Argo ATV	51-1180	'18	500 Xplorer XRT (LE)
Argo ATV	51-1180	'18	1000 Xplorer XRT (LE)
BOBCAT UTV			
BOBCAT	51-1846	'19-'20	3400 4X4
BOBCAT	51-1859	'11-'14	3200 Series
BOBCAT	51-1859	'12-'14	3400 4X4
CAMAM ATV			
CanAm	51-1005	'99-'05	500 Traxter
CanAm	51-1005	'02-'04	500 Quest
CanAm	51-1005	'02-'04	650 Quest
CanAm	51-1110	'03-'05	330 Outlander 2x4, 4x4 (XT)*
CanAm	51-1110	'03-'05	330 Outlander Max 4x4 (XT)*
CanAm	51-1110	'03-'05	400 Outlander 4X4 (XT)*

Make	Part Number	Year	Model
CanAm	51-1112	'06-'12	400 Outlander 4X4 (XT)*
CanAm	51-1112	'06-'12	400 Outlander Max 4x4 (XT)*
CanAm	51-1112	'06-'12	650 Outlander (XT)*
CanAm	51-1112	'06-'12	650 Outlander MAX (XT)*
CanAm	51-1112	'06-'12	800 Outlander MAX (XT)*
CanAm	51-1112	'07-'12	500 Outlander (XT)*
CanAm	51-1112	'11	800R Outlander (XT)*
CanAm	51-1112	'11-'12	800R Outlander MAX (XT)*
CanAm	51-1112	'12	800R Outlander (XT)*
CanAm	51-1112	'12-'15	800 Outlander (XT)*
CanAm	51-1112	'13	400 Outlander Max 4x4 (XT)*
CanAm	51-1112	'13-'14	400 Outlander 4X4 (XT)*
CanAm	51-1112	'13-'15	500 Outlander (XT)*
CanAm	51-1112	'13-'15	800 Outlander MAX (XT)*
CanAm	51-1112	'13-'18	650 Outlander MAX (XT)*
CanAm	51-1112	'13-'18	1000 Outlander 4x4 (XT)*
CanAm	51-1112	'13-'18	1000 Outlander MAX 4x4 (XT)*
CanAm	51-1112	'14-'15	400 Outlander Max 4x4 (XT)*
CanAm	51-1112	'15	400 Outlander 4X4 (XT)*
CanAm	51-1112	'16-'17	570 Outlander (XT)*
CanAm	51-1112	'16-'17	570 Outlander MAX (XT)*
CanAm	51-1115	'07-'11	800 Renegade
CAMAM UTV			
CanAm	51-18104	'13-'17	1000 Maverick
CanAm	51-1811	'11-'17	800 Commander
CanAm	51-1811	'11-'17	1000 Commander
CanAm	51-1819	'18-'19	800 Maverick Trail
CanAm	51-1819	'18-'19	1000 Maverick Trail
CanAm	51-1819	'19	1000 Maverick Sport
CAT UTV			
CAT	51-1878	'18-'19	CUV82
CAT	51-1878	'18-'19	CUV102D
CAT	51-1878	'19	CUV85 (5-Seater)
CAT	51-1878	'19	CUV105D (5-Seater)
CUB CADET UTV			
Cub Cadet	51-1822	'07-'09	Tracker
Cub Cadet	51-1822	'07-'14	Volunteer
HONDA ATV			
Honda	51-1210	'01-'04	TRX500 Rubicon (All Models)
Honda	51-1215	'95-'97	TRX450 Foreman

Make	Part Number	Year	Model
Honda	51-1215	'95-'04	TRX400 Foreman
Honda	51-1215	'98-'04	TRX450 Foreman
Honda	51-1215	'98-'04	TRX450 Rubicon
Honda	51-1220	'00-'03	TRX350 Rancher
Honda	51-1220	'00-'03	TRX400 Rancher
Honda	51-1220	'04-'06	TRX350 Rancher
Honda	51-1220	'04-'07	TRX400 Rancher
Honda	51-1225	'07-'13	TRX420 Rancher 2x4, 4x4 (All Models)
Honda	51-1225	'14	TRX420 Rancher 4X4 (IRS only)
Honda	51-1230	'03-'05	TRX650 Rincon
Honda	51-1230	'05-'06	TRX500 Foreman
Honda	51-1230	'05-'06	TRX500 Rubicon (All Models)
Honda	51-1230	'06-'17	TRX680 Rincon
Honda	51-1234-A3	'14-'17	TRX500 Foreman (All Models)
Honda	51-1234-A3	'15-'17	TRX420 Rancher 2x4, 4x4 (All Models)
Honda	51-1234-A3	'15-'18	TRX500 Rubicon (No Deluxe Models)
Honda	51-1234-A3	'18	TRX500 Foreman (All Models)
Honda	51-1234-A3	'18	TRX420 Rancher 2x4, 4x4 (All Models)
Honda	51-1234-A3	'19-'20	TRX420 Rancher 2x4, 4x4 (All Models)
Honda	51-1234-A3	'19	TRX500 Foreman (All Models)
Honda	51-1234-A3	'19	TRX500 Rubicon (No Deluxe Models)
Honda	51-1234-A3	'20	TRX520 Foreman (All Models)
Honda	51-1234-A3	'20	TRX520 Rubicon (No Deluxe Models)
Honda	51-1235	'07-'11	TRX500 Foreman
Honda	51-1235	'07-'14	TRX500 Rubicon (All Models)
Honda	51-1236	'12-'13	TRX500 Foreman S/ES/FPE
Honda	51-1240	'93-'00	TRX 300
HONDA UTV			
Honda	51-1815	'09-'13	700 Big Red MUV
Honda	51-18383	'09-'13	700 Pioneer-4
Honda	51-18383	'14-'19	700 Pioneer
Honda	51-18383	'20	700 Pioneer
Honda	51-18393	'15-'18	500 Pioneer
Honda	51-18444	'16-'20	1000 Pioneer
Honda	51-18444	'16-'20	1000 Pioneer-5
JOHN DEERE UTV			
Honda	51-1831	'93-'14	Gator 6X4
Honda	51-1831	'04-'12	Gator HPX
Honda	51-1832	'11-'15	625i Gator XUV
Honda	51-1832	'11-'15	855D Gator XUV
Honda	51-1832	'11-'15	855D Gator XUV S-4
Honda	51-1832	'11-'19	825i Gator XUV
Honda	51-1832	'13-'17	825i Gator XUV S-4
Honda	51-1832	'19	825E Gator XUV
Honda	51-1832	'19	825M Gator XUV
Honda	51-1834	'12-'15	850i Gator RSX
Honda	51-1834	'12-'17	550 Gator XUV

Make	Part Number	Year	Model
Honda	51-1834	'12-'17	550 Gator XUV S4
Honda	51-1834	'16-'17	560 Gator XUV
Honda	51-1834	'16-'17	560 Gator XUV S4
Honda	51-1834	'16-'17	590 Gator XUV S4
Honda	51-1834	'16-'19	590 Gator XUV
Honda	51-1834	'19	590E Gator XUV
Honda	51-1834	'19	590M Gator XUV
KAWASAKI UTV			
Kawasaki	51-1821	'12-'18	4000 Mule (TRANS)
Kawasaki	51-1821	'12-'20	4010 Mule (SE) (TRANS)
Kawasaki	51-1840	'05-'16	600 Mule
Kawasaki	51-1840	'05-'16	610 Mule
Kawasaki	51-1841	'17-'19	400 Mule SX (XC) (SE) (LE)
Kawasaki	51-1842	'08-'13	750 Teryx (RUV)
Kawasaki	51-1843	'12-'13	750 Teryx 4
Kawasaki	51-1843	'14-'17	800 Teryx (LE)
Kawasaki	51-1843	'14-'18	800 Teryx 4 (LE)
Kawasaki	51-1843	'19-'20	800 Teryx 4 (LE)
Kawasaki	51-1862-A	'15-'20	820 Mule Pro FXT
Kawasaki	51-1862-A	'16-'17	1000 Diesel Mule Pro (DX) (DXT)
Kawasaki	51-1862-A	'16-'20	820 Mule Pro FX (LE)
Kawasaki	51-1862-A	'18-'20	820 Mule Pro FXR
KIOTI UTV			
Kioti	51-1880	'14	2200 Mechron
KUBOTA UTV			
Kubota	51-1812	'04-'09	900 RTV 4X4 (1-1/4" Receiver)
Kubota	51-1812	'08-'10	1100 RTV 4X4 (1-1/4" Receiver)
Kubota	51-1813	'10-'16	900 RTV 4X4 (2" Receiver)
Kubota	51-1813	'10-'16	1140 RTV 4X4 Crew (2" Receiver)
Kubota	51-1814	'09-'16	500 RTV 4X4 (2" Receiver)
Kubota	51-1814	'12-'16	400ci RTV 4X4
Kubota	51-1816	'11-'12	1100 RTV 4X4 (Rect. Tube Bumper)
POLARIS ATV			
Polaris	51-1400	'91-'99	Sportsman 6X6
Polaris	51-1400	'93-'95	Sportsman
Polaris	51-1400	'96-'97	Xplorer 400L (Shaft Drive)
Polaris	51-1400	'96-'98	Xplorer 400 (Chain Drive)
Polaris	51-1400	'97	Xplorer 500 (Shaft Drive)
Polaris	51-1400	'98-'02	Xplorer 400 (Shaft Drive)
Polaris	51-1407	'02-'04	600 Sportsman
Polaris	51-1407	'02-'04	700 Sportsman
Polaris	51-1407	'04	500 Sportsman
Polaris	51-1410	'98-'03	500 Sportsman
Polaris	51-1410	01-'04	400 Sportsman
Polaris	51-1410	'03-'06	330 Magnum 4x4
Polaris	51-1410	'04-'05	330 ATP
Polaris	51-1410	'04-'05	500 ATP

Make	Part Number	Year	Model
Polaris	51-1413	'11	800 Sportsman
Polaris	51-1413	'11-'13	500 Sportsman
Polaris	51-1413	'11-'14	400 Sportsman
Polaris	51-1413	'12	500 Sportsman Touring
Polaris	51-1413	'12-'14	800 Sportsman
Polaris	51-1413	'12	800 Sportsman Big Boss 6X6
Polaris	51-1413	'14	500 Sportsman
Polaris	51-1413	'14	570 Sportsman
Polaris	51-1413	'14	Sportsman Touring
Polaris	51-1413	'15-'19	570 Sportsman
Polaris	51-1413	'15-'19	570 Sportsman SP
Polaris	51-1413	'15-'18	570 Sportsman Touring
Polaris	51-1413	'15	570 Sportsman X2
Polaris	51-1413	'15	Sportsman ETX
Polaris	51-1413	'16-'19	450 Sportsman (H.O.)
Polaris	51-1413	'16-'18	570 Sportsman X2
Polaris	51-1413	'16-'19	850 Sportsman High Lifter
Polaris	51-1413	'18	570 Sportsman 6x6
Polaris	51-1413	'18-'19	850 Scrambler
Polaris	51-1413	'19	850 Sportsman Touring (SP)
Polaris	51-1413	'20	570 Sportsman
Polaris	51-1414	'09-'11	550 Sportsman XP
Polaris	51-1414	'09-'14	850 Sportsman
Polaris	51-1414	'10-'14	550 Sportsman
Polaris	51-1414	'10-'14	550 Sportsman X2
Polaris	51-1414	'10-'14	850 Sportsman Touring
Polaris	51-1414	'10	850 Sportsman X2
Polaris	51-1414	'11	850 Sportsman X2
Polaris	51-1414	'13-'14	850 Scrambler XP
Polaris	51-1414	'13-'17	850 Scrambler
Polaris	51-1414	'14-'17	1000 XP Scrambler
Polaris	51-1414	'15-'18	850 Sportsman
Polaris	51-1414	'15-'18	850 Sportsman Touring (SP)
Polaris	51-1414	'15-'18	1000 XP Sportsman
Polaris	51-1414	'15-'18	1000 XP Sportsman Touring
Polaris	51-1414	'19	850 Sportsman (SP)
Polaris	51-1414	'19	1000 XP Sportsman
Polaris	51-1414	'20	850 Sportsman
Polaris	51-1415	'05-'07	600 Sportsman
Polaris	51-1415	'05-'08	700 Sportsman
Polaris	51-1415	'05-'10	500 Sportsman
Polaris	51-1415	'05-'10	800 Sportsman
Polaris	51-1415	'05	400 Sportsman
Polaris	51-1415	'06-'07	400 Sportsman
Polaris	51-1415	'06	500 Sportsman X2

Make	Part Number	Year	Model
Polaris	51-1415	'07-'08	500 Sportsman X2
Polaris	51-1415	'07	800 Sportsman X2
Polaris	51-1415	'08-'09	500 Sportsman Touring
Polaris	51-1415	'08-'09	800 Sportsman Touring
Polaris	51-1415	'08	700 Sportsman X2
Polaris	51-1415	'09	500 Sportsman X2
Polaris	51-1415	'09	800 Sportsman X2
Polaris	51-1425	'06-'07	300 Hawkeye
Polaris	51-1425	'08-'09	400 Hawkeye
Polaris	51-1425	'08-'09	400 Sportsman
Polaris	51-1425	'08-'10	300 Sportsman
POLARIS UTV			
Polaris	51-1847	'10-'14	400 Ranger 4X4 Midsize
Polaris	51-1847	'11-'13	500 Ranger 4X4 Midsize (Crew)
Polaris	51-1847	'11-'17	Ranger EV 4X4 Midsize
Polaris	51-1847	'13-'14	800 Ranger 4X4 Midsize (2-Seater)
Polaris	51-1847	'15-'16	Ranger ETX Midsize 4x4
Polaris	51-1847	'17-'18	500 Ranger 4X4 Midsize
Polaris	51-1848	'98-'01	Ranger 6X6
Polaris	51-1849	'01-'04	Ranger 4X4
Polaris	51-1850	'05-'08	Ranger (All CC'S)
Polaris	51-1850	'05-'08	Ranger XP (All CC'S)
Polaris	51-1850	'08-'09	700 Ranger Full Size Crew
Polaris	51-1851	'10-'14	800 Ranger Full Size 4x4 [3-Seater] (XP) (HD)
Polaris	51-1852	'08-'14	800 RZR
Polaris	51-1852	'10-'14	800 RZR-4
Polaris	51-1852	'12-'18	570 RZR
Polaris	51-1853	'11-'14	900 RZR
Polaris	51-1853	'11-'14	900 RZR-4
Polaris	51-1853	'15-'18	900 RZR
Polaris	51-1854	'13-'19	900 XP Ranger Full Size
Polaris	51-1854	'14-'18	900 XP Ranger Crew
Polaris	51-1854	'14-'18	900 XP Ranger Crew
Polaris	51-1854	'15-'17	Ranger Diesel
Polaris	51-1854	'15	570 Ranger Full Size (3-Seater)
Polaris	51-1854	'17-'18	1000 XP Ranger Full Size 4x4 Crew
Polaris	51-1854	'17	1001 XP Ranger Full Size 4x4
Polaris	51-1857	'14-'18	570-4 Ranger 4X4 Midsize Crew (4-Seater)
Polaris	51-1857	'14-'19	570 Ranger 4X4 Midsize (2-Seater)
Polaris	51-1857	'16-'18	570-6 Ranger Full Size Crew (6-Seater) 4x4 (Round Tube/800 Body Style)
Polaris	51-1857	'16-'19	570 Ranger Full Size (3-Seater) 4x4 (Round Tube/800 Body Style)

Make	Part Number	Year	Model
Polaris	51-1857	'19	Ranger EV 4X4 Midsize
Polaris	51-1858	'14-'18	1000 RZR XP
Polaris	51-1858	'14-'18	1000 RZR XP-4
Polaris	51-1858	'15-'17	900 RZR-4
Polaris	51-1858	'15-'18	900 RZR S
Polaris	51-1858	'15-'17	900 RZR XC
Polaris	51-1858	'16-'17	900 RZR Trail
Polaris	51-1858	'16-'18	1000 General
Polaris	51-1858	'16-'18	1000 RZR S
Polaris	51-1858	'16-'18	Turbo RZR XP
Polaris	51-1858	'16-'18	Turbo RZR XP-4
Polaris	51-1858	'18	900 RZR S-4
Polaris	51-1885	'18-'20	1000 XP Ranger Full Size 4x4
Polaris	51-1885	'19-'20	1000 XP Ranger Full Size 4x4 Crew
Polaris	51-1885	'20	1000 Ranger

SUZUKI ATV

Suzuki	51-1505	'02-'06	500 Vinson
Suzuki	51-1505	'07	500 Vinson
Suzuki	51-1510	'08-'17	400 King Quad
Suzuki	51-1515	'01-'02	300 King Quad
Suzuki	51-1520	'99-'00	300 King Quad
Suzuki	51-1530	'05-'07	700 King Quad 4x4
Suzuki	51-1530	'06	450 King Quad
Suzuki	51-1530	'07-'10	450 King Quad
Suzuki	51-1530	'08-'16	700 King Quad 4x4
Suzuki	51-1530	'08-'17	750 King Quad 4x4
Suzuki	51-1530	'09-'17	500 King Quad
Suzuki	51-1530	'11-'12	450 King Quad
Suzuki	51-1335	'04-'06	700 Twin Peaks

TEXTRON UTV

Textron	51-1878	'18-'19	Prowler Pro (XT)
Textron	51-1878	'19	Prowler Pro Crew (XT)

YAMAHA ATV

Yamaha	51-1605	'02-'08	660 Grizzly 4x4
Yamaha	51-1610	'98-'01	600 Grizzly 4x4
Yamaha	51-1615	'03-'06	450 Grizzly
Yamaha	51-1615	'03-'07	400 Kodiak
Yamaha	51-1615	'03-'12	450 Kodiak
Yamaha	51-1615	'04-'06	350 Bruin 2x4, 4x4
Yamaha	51-1615	'05-'07	400 Grizzly
Yamaha	51-1615	'07-'09	350 Grizzly 2x4, 4x4
Yamaha	51-1615	'07-'12	450 Grizzly
Yamaha	51-1615	'13-'14	350 Grizzly 2x4, 4x4
Yamaha	51-1618	'16	700 Grizzly 4x4

Make	Part Number	Year	Model
Yamaha	51-1618	'16	700 Kodiak 4x4
Yamaha	51-1618	'17-'20	700 Kodiak 4x4 (SE)
Yamaha	51-1618	'17-'20	Grizzly 4x4 (LE) (SE)
Yamaha	51-1618	'17	700 Grizzly 4x4
Yamaha	51-1618	'19	700 Grizzly 4x4
Yamaha	51-1620	'00-'02	400 Kodiak
Yamaha	51-1625	'07-'08	550 Grizzly 4x4
Yamaha	51-1625	'07-'12	700 Grizzly 4x4
Yamaha	51-1625	'09-'12	550 Grizzly 4x4
Yamaha	51-1625	'13-'14	550 Grizzly 4x4
Yamaha	51-1625	'13-'14	700 Grizzly 4x4
Yamaha	51-1625	'15	700 Grizzly 4x4
Yamaha	51-1640	'07-'09	400i Big Bear
Yamaha	51-1640	'07-'11	400 Big Bear 2x4, 4x4
Yamaha	51-1650	'97-'06	400 Big Bear 2x4, 4x4
Yamaha	51-1655	'95-'05	350 Wolverine
Yamaha	51-1660	'06-'08	450 Wolverine

YAMAHA UTV

Yamaha	51-1635	'04-'08	660 Rhino
Yamaha	51-1635	'06-'11	450 Rhino
Yamaha	51-1635	'06-'13	700 Rhino
Yamaha	51-1637	'16-'17	Wolverine
Yamaha	51-1637	'16-'17	Wolverine R-Spec (SE)
Yamaha	51-1836	'14-'18	Viking
Yamaha	51-1836	'15-'18	Viking VI



TRUCK & SUV MOUNTS

Protect your vehicle and your winch with our custom built Xtreme II grille guards. All incorporate a 1/4 inch thick mounting steel plate and can accommodate up to a 15,000 pound Mile Marker winch. Optional "wraparound" brush guards can be added to finish out the protection. See chart on the next page for vehicle specific application guide.

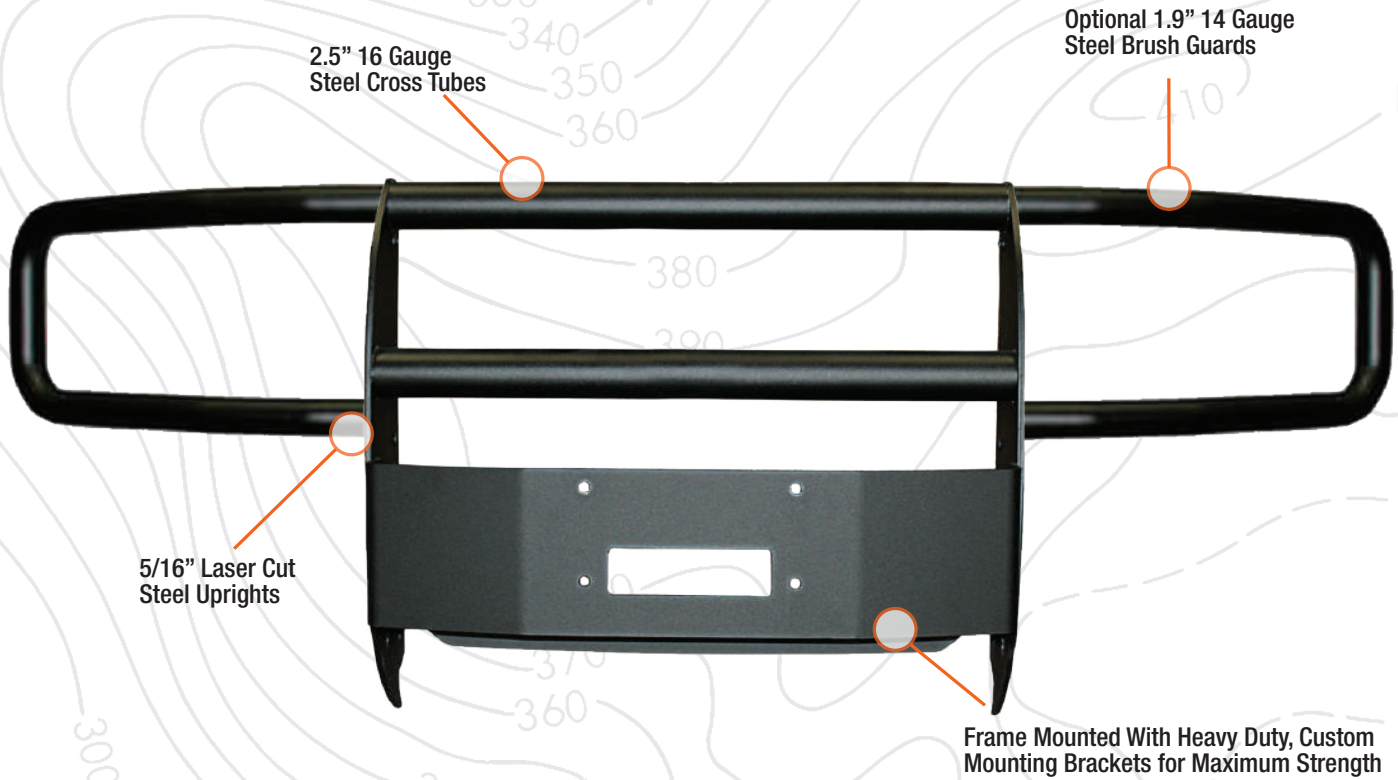

Mount (With Brush Guard)

TRUCK & SUV

MOUNT APPLICATION GUIDE

Year	Make & Model	Part Number & Mount Model			
		Grille Guard (up to 15,000 Lb winches)	Grille Guard (up to 15,000 Lb winches)	Brush Guard	Brush Guard
		CHROME	BLACK	CHROME	BLACK
CHEVROLET					
'15-'19	Silverado 2500HD/3500 (7)	50-35752C	50-35752	50-26736C	50-26736
'11-'14	Silverado 2500HD/3500 (7)	50-35751C	50-35751	50-26751C	50-26751
'16-'18	Silverado 1500 (4) (7)	50-35746C	50-35746	50-26736C	50-26736
'14-'15	Silverado 1500 (4) (7)	50-35736C	50-35736	50-26736C	50-26736
'07-'13	Silverado 1500 (4) (7)	50-35735C	50-35735	50-26735C	50-26735
'07-'10	Silverado/Classic 2500HD/3500 Classic (1)	50-35738C	50-35738	50-26738C	50-26738
DODGE					
'10-'19	Ram 2500/3500 (3) (7) (10)	50-35669C	50-35669	50-26669C	50-26669
'07-'19	Ram 3500-5500 Chassis Cab (7)	50-35665C	50-35665	50-26663C	50-26663
'09-'18	Ram 1500 classic body (3) (7) (10)	50-35671C	50-35671	50-26669C	50-26669
'19- +	Ram new body		50-35673		
FORD					
'10-'13	Expedition (4) (6) (7)		50-35619		
'17-'19	Super Duty F250-550 (7) (8) (10)	50-35647C	50-35647	50-26647C	50-26647
'11-'16	Super Duty F250-550 (7) (10)	50-35644C	50-35644	50-26644C	50-26644
'08-'10	Super Duty F250-F550 (2) (7)	50-35642C	50-35642	50-26642C	50-26642
'09-'13	F150 (2) (4) (5) (6) (7)	50-35639C	50-35639	50-26639C	50-26639
'15-'17	F150 (7) (8) (9) (10)	50-35650C	50-35650	50-26650C	50-26650
'06-'08	F150 (1)	50-35637C	50-35637	50-26637C	
GMC					
'15-'19	Sierra 2500HD/3500 (1) (7)	50-35754C	50-35754		
'11-'14	Sierra 2500HD/3500 (1) (7)	50-35751C	50-35751	50-26751C	50-26751
'14-'18	Sierra 1500 (1) (4) (7)	50-35749C	50-35749		
'07-'13	Sierra 1500 (1) (4) (7)	50-35745C	50-35745		
NISSAN					
'05-'12	Pathfinder		50-35160		

Product Guide

1. Will not fit Denali Models or Denali Style Grilles
2. Will not fit Harley Davidson Models
3. Will not fit Ram Sport or Plastic Bumpers
4. Trimming may be required
5. Will not fit Lariat Limited
6. Will not fit F-150 EcoBoost
7. Interferes with front bumper sensors
8. May interfere with adaptive power steering
9. Will not work with 5.0 V8 Engines
10. Will interfere with OEM front facing cameras

CHANNEL MOUNTS

TRUCK/SUV MOUNTING SYSTEMS

The simple mounting solution for your vehicle, these mounts can be welded or bolted to adapt to almost any application. All are made from 1/4" high quality steel and finished with a black powder coat.

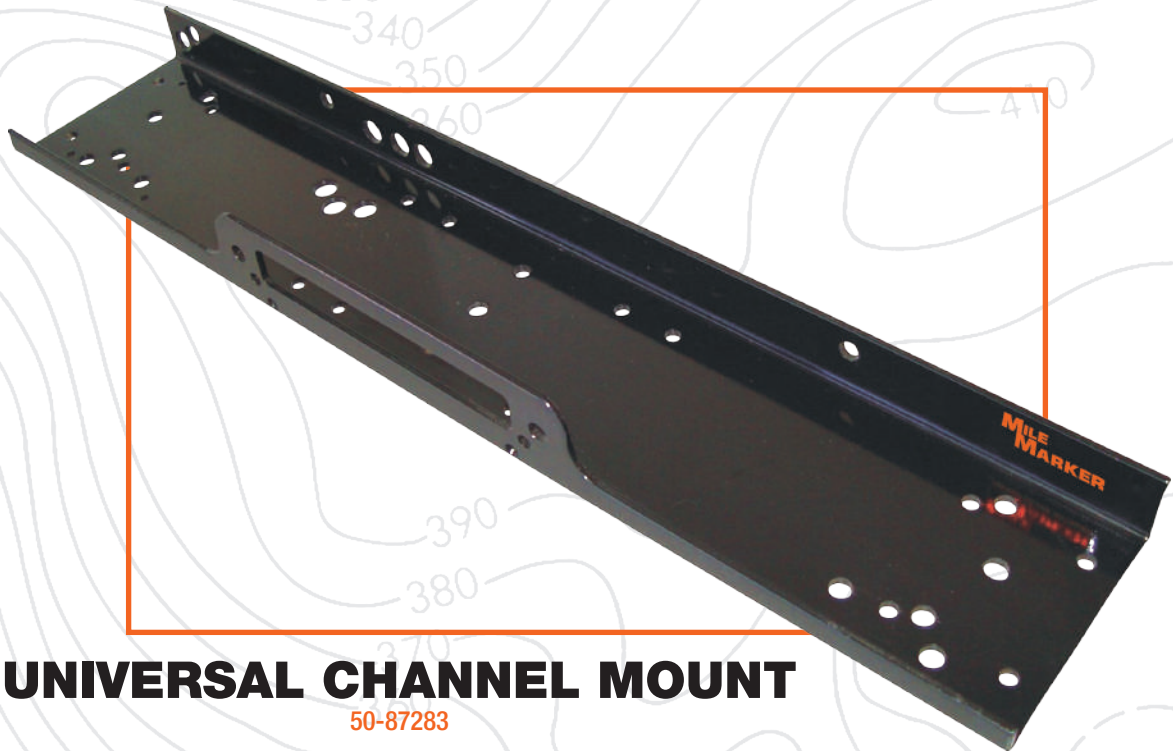

UNIVERSAL CHANNEL MOUNT

50-87283



TRAILER MOUNT

60-50015

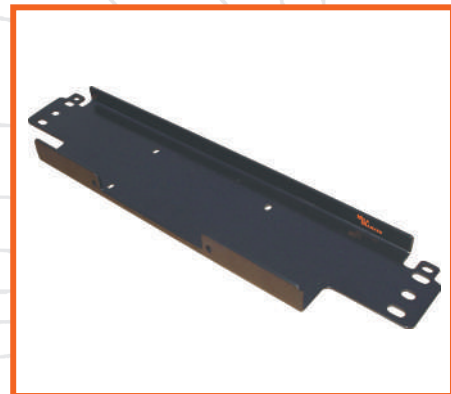

JEEP WRANGLER (TJ/YJ)

60-50059

RECEIVER MOUNTS



DETACHABLE MOUNTING SYSTEMS

Mile Marker's receiver mounts are detachable, providing versatility needed to move winches from back to front or from vehicle to vehicle. Simply add quick disconnect wiring and you're ready to go (see page 32 for quick disconnect kits).



FULL SIZE CRADLE MOUNT

60-06495



RECEIVER MOUNT DESIGNED
TO WORK WITH ATV/UTV WINCHES

51-06496



ATV/UTV RECEIVER MOUNT

51-4677

RECOVERY GEAR

Choose the right kit for you.
You can count on Mile Marker recovery gear to overcome the elements.



Off Road Recovery Kit: 19-00100

Everything you need to get out of a pinch. In the event of a snap, our winch dampener directs the cable to the ground and keeps you safe. Doubling as the bag, it houses a 15' recovery strap, gloves, 20K snatch block with grease fitting, and two powder coated shackles.



ATV/UTV Recovery Kit: 19-00105

Push your ATV or UTV to the limits. Includes: two powder coated shackles, gloves, 8K snatch block, and two 8 ft. recovery straps. Housed in a durable carrying case with strap.





Orange Powder Coated Shackles

3/4" Shackle **60-50134**

5/8" Shackle **60-50158**

Orange powder coated shackles. Working load limit of 4.75 tons for the 3/4" shackles and 3.2 tons for the 5/8" shackles.



Steel Hitch Receiver With D-Ring

60-65000C

Zinc coated, forged cast, solid steel hitch receiver fits standard Class III hitches with 2" receivers. Includes a 4-way hole system and a 3/4" orange shackle to meet any mounting needs.



Recovery Gloves

(XL) **30-19-G2**

Protect your hands from cable burns and rope burns. Gloves feature cowhide palms, with SBR padding and neoprene lines for breathability and functional dexterity.



Recovery Strap 15' & 30'

3" X 15' **19315**

3" X 30' **19330**

15' and 30' Recovery Straps rated to 30,000 pound capacity.



ATV Recovery Strap 8'

1" X 8' **19108**

8' Recovery Strap rated to 7,200 pounds, with reinforced eyelet on each end.



Tree Saver Strap 6'

4" X 6' **19406**

Be conscious of your environment with this 6' Tree Saver strap. This Tree Saver Strap is rated to 50,000 pounds.



Industrial Snatch Block 30K

60-50185

The Industrial Grade Snatch Block is rated up to 30,000 pounds of pull. Reduces the load on the winch by half to enable you to retrieve loads up to double your winch's capacity. Also allows winching from various angles. Features grease fitting and brass bushing.



Heavy Duty Snatch Block 20K

60-50083

The Heavy Duty Snatch Block is rated up to 20,000 pounds. Reduces the load on the winch by half to enable you to retrieve loads up to double your winch's capacity. Also allows winching from various angles. Features grease fitting and brass bushing.



ATV/UTV Snatch Block 8K

60-50105

This snatch block is rated up to 8,000 pounds. Reduces the load on the winch by half to enable you to retrieve loads up to double your winch's capacity. Also allows winching from various angles.

WINCH ACCESSORIES



Wireless Remote
7076

WINCH WITHOUT WIRES

The plug & play wireless remote operates your winch from anywhere up to 50 feet away! Simply plug a receiver into your control box and you're ready to winch. Can adapt to most electric and hydraulic winches.



WIRELESS OPERATION UP TO 50 FT AWAY



ADAPTS TO MOST ELECTRIC WINCHES

QUICK DISCONNECT KITS

Adding a quick disconnect kit allows for easy winch removal. Move your winch from the front to the back of your vehicle, or switch vehicles, whenever you need. Best used in conjunction with a receiver style mount.

JEEP/TRUCK/SUV



Electric Front Quick Disconnect Kit
76-93-54000



Electric Rear Quick Disconnect Kit
76-93-53000

POWERSPORTS



ATV/UTV Front Quick Disconnects
93-53106



ATV/UTV Rear Quick Disconnects
10' 93-53105 / 12' 93-53108

HYDRAULIC



Hydraulic Front Quick Disconnect Kit
70-54000



Hydraulic Rear Quick Disconnect Kit
70-53000



Replacement Solenoid

PE2.5 & PE3.5 77-50105-37
Full size winches 77-50141W-31



Roller Fairlead Cover 8402

This impact resistant cover protects your Mile Marker WH-10 roller fairlead from weather and debris while adding a finished look to the front of your vehicle.



Neoprene Winch Covers
Wraps snugly around your winch for all weather protection

Fits most ATV winches 8505
Fits most full size winches 8506



Roller Fairlead WH-18

Works with 18,000 lb. winches



Roller Fairlead WH-10

Universal roller fairlead works with 8000-15000 pound winches. Also fits winch mount bumpers.



Powersports Winch Rollers

For winches 5000 pounds ONLY WH-5
For winches 4500 pounds ONLY WH-4
For winches 2500-3500 pounds WH-2
For winches 2000 pounds ONLY WH-1



Aluminum Hawse Fairlead

For use with synthetic rope
(ATV/UTV) 19-52000
(PE5000) 19-52005
(Full Size) 19-53000



Handlebar Remote 93-50106E

For use with Mile Marker ATV/UTV winches. Adjustable mount provides accessible control to your trail blazing ATV.



Electric & Hydraulic Remote 77-50141W-50

For use with Mile Marker electric winches with standard solenoids.



Winch Shackle Mount 60-12166

Upgrades the conventional winch hook for a clean and sophisticated look on the front of the vehicle and an easy mount for your shackle. Mounts either a 5/8" or 3/4" shackle. Rubber construction will not rust or rattle in travel.



Replacement Cable

5/16" X 100' 19-50010C
3/8" X 100' 19-50020C
Steel cable with removable hook.



Synthetic Rope

19-52038-100C *
3/8" X 92' Gray Rope Assembly
(16,200 lbs. Min Break Force)
19-52516-100C *
5/16" X 92' Gray Rope Assembly
(11,700 lbs. Min Break Force)
19-52014-50
1/4" X 50' Gray Rope Assembly
(7,740 lbs. Min Break Force)
19-52316-50
3/16" X 50' Orange Rope Assembly
(5,440 lbs. Min Break Force)



2000 lb. Winch Remote

76-50100-20

Fits most utility 12V winches

Attached hook included *

TRANSFER CASE CONVERSION KITS

For owners of full time 4WD vehicles, convert from 4WD to 2WD effortlessly. Conversion kits reduce wear and tear on your drivetrain, saving you money at the gas pump and providing years of trouble free service.

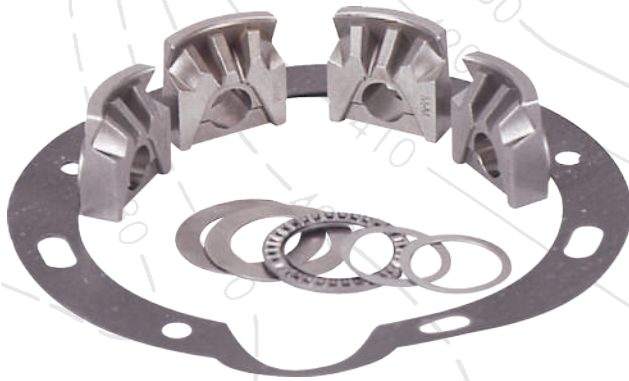

FORD & GM 203 NEW PROCESS

203 Transfer case without hubs **501**

With premium 1/2 Ton hubs **502**
(also fits '78-'79 3/4 Ton)

With premium locking hubs **503**
Fits '73-'77 3/4 Ton

With premium locking hubs **505**
1 Ton GM, Ford

Bearing kit **701**

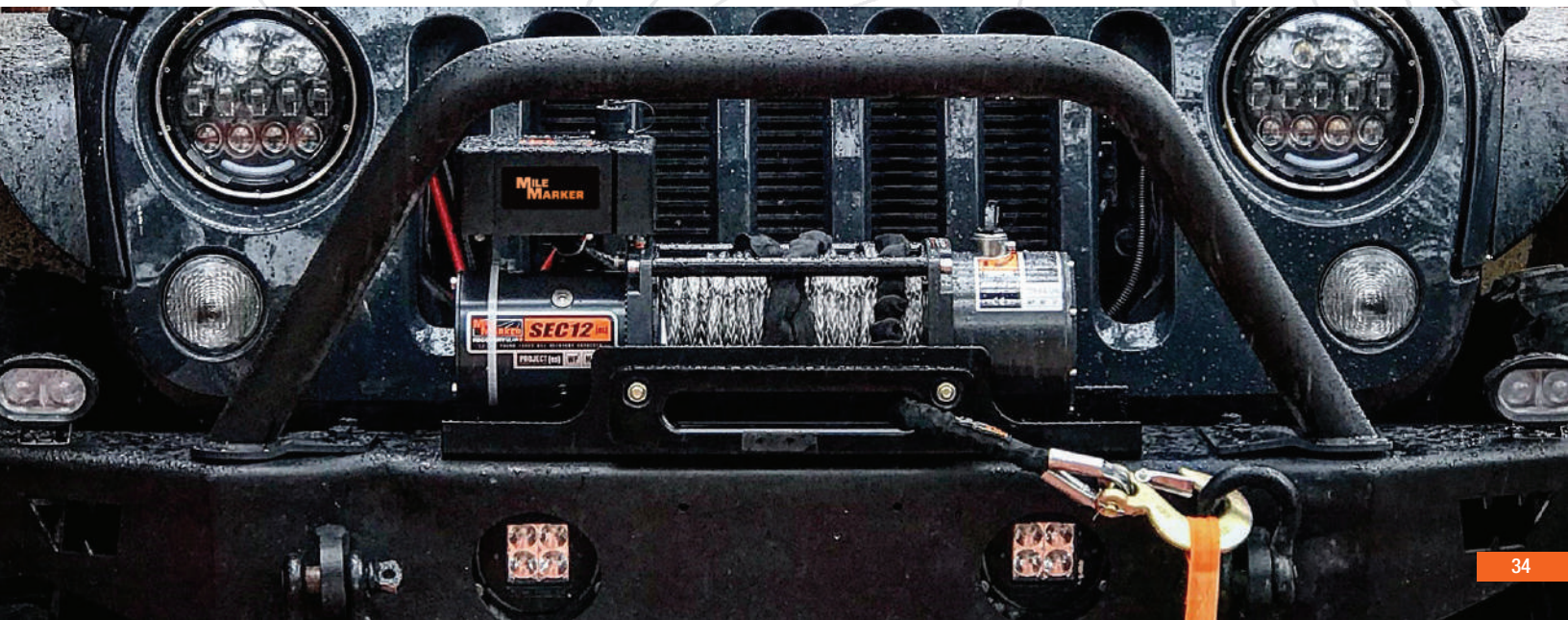

PREMIUM LOCKING HUBS

Mile Marker hubs allow you to manually lock your vehicle into 4 wheel drive and are built to last through all weather and terrain. Use the two guides to choose the right hub for your vehicle and the correct conversion kit if needed (see next page for conversion kits)



104



302



426



428



449SS

HUB SPECIFICATION GUIDE

All specifications must match exactly for hub to fit.

Part Number	Bolt Circle	# of Bolts	# of Splines	Axle O.D.
104		Internal	19	1.250
302		Internal	19	1.250
423	3.750	6	19	1.250
426	Internal	Internal	27	1.210
427	4.500	5	23	1.016
428	4.500	5	27	1.206
430	3.260	6	27	1.094
435	3.260	6	28	1.143
436	3.543	6	26	1.080
449SS		Internal	30	1.312

Part Number	Bolt Circle	# of Bolts	# of Splines	Axle O.D.
457	3.437	6	27	1.187
459SS		Internal	35	1.500
460	76	6	26	91
466	3.543	6	30	1.300
470	3.440	5	27	1.187
481	3.437	6	10	1.125
490	3.543	6	26	1.100
549	4.016	6	35	1.422
11034-01	3.960	8	30	1.312
95-37044	4.500	5	19	1.250



BUILT TO LAST



MADE FOR EXTREME TRACTION

HUB APPLICATION GUIDE

Vehicle Model/Year	Part Number	Vehicle Model/Year	Part Number	Vehicle Model/Year	Part Number
AMC/JEEP		1 Ton Dana 50 & 60 Axle '76 - '04 (A,B) *	449SS	KIA	
Cherokee '74 - '87	104, 302	F-150 '59 - '81(A,B) ***	104, 302	Grand Sportage '97 - '02	460
CJ Universal '42 - '71	481	F-150 '82 - '96 (A,B) *	104, 302	Sportage '97 - '02	460
CJ Universal '72 - '86	457	F-250 '99 - '04	449SS	MAZDA	
CJ Universal '80 - '86	470	F-250 ex. F/T '59 - '98 ***	449SS	B3000 '01 - '08	426
Gladiator '74 - '87	104, 302	F-250 '05 - '20	549	B4000 '01 - '08	426
J10 Pickup '74 - '80	104, 302	F-350 '88 - '98 ***	449SS	Navajo '90 - '94 (A) *	428
J20 Pickup '74 - '77	423	F-350 '99 - '04	449SS	Pickup '94 - '97 (A) *	428
J20 Pickup '78 - '90	104, 302	F-350 Dana 50 & 60 Axle '76 - '04 (A,B) *	449SS	NISSAN	
Wagoneer '71 - '73	457	F-350 '05 - '20	549	1/2 Ton P/U '85 1/2 - '89	430
Wagoneer '74 - '87	104, 302	F-450 '88 - '98 ***	449SS	Frontier '98 - '04	435
CHEVROLET/GMC		F-450 '99 - '04	449SS	Hardbody (6 Bolt 27 Spline) '86 1/2 - '89	430
1/2 Ton Pickup (K10) '69 - '87	104, 302	F-450 Dana 50 & 60 Axle '76 - '04 ***	449SS	Hardbody '90 - '97	435
3/4 Ton Pickup '78 - '87	104, 302	F-450 '05 - '20	549	Pathfinder (6 Bolt 27 Spline) '86 1/2 - '89	430
Blazer '69 - '91	104, 302	F-550 '99 - '04	449SS	Pathfinder '90 - '01	435
Chevy 3/4 Ton (K-20) Pickup '60 - '77	423	F-550 '05 - '20	549	Xterra '00 - '04	435
Chevy IT (K-30) Pickup '77 - '87	449SS	Bronco '66 - '96 (A, B) *	104, 302	All Nissan (6 Bolt 28 Spline) - ALL	435
Chevy IT Dana 50 & 60 Axle '77 - '87	449SS	Bronco II '83 - '90 (A) ***	427	SUZUKI	
Jimmy '69 - '91	104, 302	Excursion '99 - '04	449SS	Samurai '82 - '98	436
Suburban '69 - '91	104, 302	Explorer '90 - '94 (A) ***	428	Sierra '82 - '98	436
CHRYSLER/PLYMOUTH/DODGE		Ranger '83 - '97 (A) ***	428	TOYOTA	
1/2T W-100 P/U '57 - '68	423	Ranger '98 - '00 (A) **	426	4 Runner '76 - '98 ***	490
1/2T W-100 P/U '69 - '93	104, 302	GEO		4 Runner 4x4 Pickup '86 - '94	490
3/4 Ton W-200 Pickup except full-time 4WD - ALL	423	Tracker (all)	436	Hilux '76 - '98 ***	490
1 Ton W-300 Series '76 - '89	11034-01	INTERNATIONAL HARVESTER		Land Cruiser '63 - '98 ***	490
1 Ton Dana 50 & 60 Axle '90 - '93	449SS	1/2 Ton Pickup '64 - '73	104, 302	Land Cruiser '76 - '85	466
RAM Charger '80 - '93	104, 302	1/2 Ton Pickup '74 - '75	457	Pickup '76 - '85	466
Trail Duster '80 - '93	104, 302	3/4 Ton Pickup '56 - '75	423	Pickup '76 - '98 ***	490
FORD		1 Ton HD. 200 with FA-20 Axle - ALL	11034-01	T-100 '93 - '98	490
3/4 Ton P/U w/Spline wheel hub (A,B) - ALL *	104, 302	Scout '61 - '71	481	HEAVY DUTY	
3/4 Ton w/3500 Axle ex. F/T '63 - '77	423	Scout II (ex. F/T) '72 - '80	457	35 spline Dana 70 hub	459SS
1 Ton Pickup '59 - '96 ***	449SS	Travel-all 1/2 Ton '64 - '73	104, 302		
		Travel-all 1/2 Ton '74 - '75	457		
		Travel-all 3/4 Ton '56 - '75	423		

Nut Conversion Kits

104, 302	95-32720
427	95-27988
428	95-27997
449SS	95-32721
490	95-29918

- A. If OEM automatic hubs, a conversion kit is required to convert to manual hubs
- B. '73-'79 vehicles with full-time 4 wheel drive require a transfer case conversion kit
- * Nut Conversion Kit required
- ** Not required on these model years 99-04
- *** Depending on application Nut Conversion Kit may be required





**MILE
MARKER**



Check out the collection of ATV/UTV winches and accessories we offer.