



Specialty Products Company®

2020 - 2021 Total Wheel Alignment Sourcebook™

55
Racing

Import

Off-Road

Muscle

Domestic

Heavy Duty

Performance

Drift

Toe

Caster

Camber

New Alignment Parts and Tools

Look for our "New" logo on over 45 new parts and tools throughout this Sourcebook for the latest in alignment technology including:



Acura RDX Rear Camber Arm & Cam . . .	99	Honda Accord Adj. Rear Camber Arm . .	98
Alignment Spec Book - 2011 - 2020. . .	184	Hyundai/Kia Rear Camber Cam	126
Audi A4 Rear Toe Kit	120	Hyundai/Kia Rear Toe Cam	125
Audi Front Multi Link Arm Set	119	Jeep JL & JK Suspension Arms.	73
Audi Pinch Bolt Kit	152	Jeep JL Caster and Pinion Cams.	123
Chevy Colorado Adj. Control Arm	130	Jeep JL Wrangler Camber Sleeves	76
Chevy Corvette Adj. Control Arm	140	Mazda3 Rear Camber/Toe Kit & Cam . .	93
Dodge/Chrysler LX Cams.	86	Mopar A, B & E Adj. Control Arm	140
Ford Expedition Adj. Camber Arm	90	Nissan Versa Camber/Toe Shims	105
Ford Expedition Rear Camber Kit	131	Porsche 996/997 Performance Kit	113
Ford Mustang II Adj. Control Arm	140	Slot Punch Tools.	170
Ford Mustang Rear Performance Kit . .	112	SPC Replacement Parts Mouse Pad. . .	182
Ford Mustang Rear Toe Link.	150	SPC Tape Measure	175
Ford Ranger Adj. Upper Control Arm . .	82	Temsa Single Slot Tandem Shims. . . .	142
GM Heavy Duty Truck Tool	167	xAxis™ Sealed Flex Joints.	158

High Rate Rubber Bushings

- Maintains OE NVH (Noise, Vibration and Harshness) levels
- Longer life vs rod ends
- Provides performance handling

2 Lock Plates for OE Slot

- No slippage

All hardware included

- Bolts, nuts, plates, cams, inserts, washer for both ends of arm
- Hex chromate free, environment friendly, 700 hr salt spray tested for rust-free long life

Fully Forged Aluminum Arm

- 11% weight saving vs. OE arm
- Maintains factory frame and drive shaft clearance
- Exceeds OE strength

S550 Mustang Rear Camber Arm

-2° to +3° Camber Change

- Improve rear tracking and handling
- Fine-tune change with eccentric insert
- Easy 'live' adjustment with the wheel on

Innovating for the future

For more on our Mustang rear camber/toe kit (p/n 72360) for 2015 & Up Ford Mustangs see page 112.

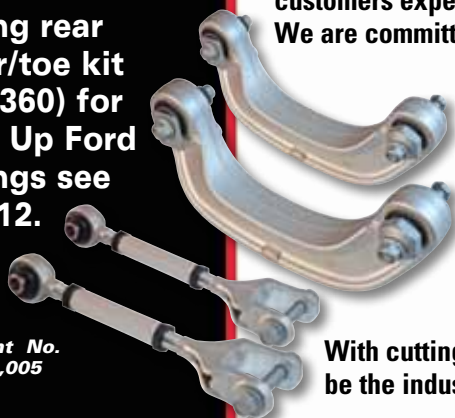

US Patent No. 10,450,005

Specialty Products has lead the alignment industry for over 40 years and our customers expect SPC to have the best parts and tools in the alignment market. We are committed to not only meet but exceed those expectations.

Being the industry leader also means SPC is the first to market with innovative alignment solutions. Our new Rear Camber Arm (p/n 72370) for the popular S550 Mustang platform is quickly becoming the standard. SPC's race proven, forged aluminum link incorporating both fixed and eccentric adjusters, is proven to be reliable for the >1,000 pounds of force that will be loaded as these vehicles are put to the test, while providing weight savings vs the OE arm.

With cutting edge engineering and real-world experience SPC continues to be the industry's first choice in alignment parts and tools.



Entire contents © 2020
 Niwot Corporation,
 dba
 Specialty Products
 Company®.



**TOOL
 ICON**

*When you see our 'Wrench'
 next to a part it means there
 is a special tool available to
 assist you in the installation*

The design, shape,
 format and
 arrangement of
 this catalog constitutes
 a trademark of
 Specialty Products
 Company.
 Printed in U.S.A.

All rights reserved,
 reproduction in whole or in part
 without permission is prohibited.
 Total Wheel Alignment Sourcebook
 is a trademark of
 Niwot Corporation.

Table of Contents

INTRO/APPLICATIONS..... 2-70

Here is where you can find our parts and tools - a quick look-up for everything from a 2003 Honda Accord to a Sterling Bullet.

Includes our Stock Replacement Parts

How to Use the Sourcebook.....	2
How to Sell Alignment.....	2
Training Resources.....	3
Explanation of Alignment.....	4-6
Passenger Car/Mini-Van/Truck & SUV Applications.....	7-70
Footnotes/VIN Information/Toe Conversion Table.....	70

PARTS 71-140

Find out more about the part you need. In this section you will find detailed information about our parts such as degree of change, install times, and helpful tech tips.

Inventory Control Boards.....	77-72
Alignment Parts.....	73-134
Muscle Car Parts.....	135-140

HEAVY DUTY..... 141-149

We carry a complete line of alignment parts, tools and accessories for OTR vehicles. From Freightliners to Tandem Alignment systems, we have you covered.

Heavy Duty Truck Shims and Parts.....	141-149
Wheel Centering Products.....	145-147
Truck Gauges and Heavy Duty Truck Tools.....	148-149

OE REPLACEMENT..... 150-153

Specialty carries OE replacement suspension components. To get your alignment in the green you may just need to replace an OE part that is worn. Check to see if SPC has it and get the quality you expect.

RACING/OFF ROAD 154-161

SPC is the builder's choice for the best in suspension components. From adjustable, rugged upper control arms to our Builders Series featuring xAxis™ Sealed Flex Joints and rebuildable ball joints.

Customize your Arm 154	
Pre-built Arms.....	155
Component Parts - Cross Shafts, Adjustable Sleeves, Plates, and More.....	156-157
xAxis™, Rod Ends and Receivers, Builder Ball Joints, and More.....	158-160
Racing Tools & Equipment.....	161

TOOLS 162-176

Find our innovative FasTrax™ Camber/Caster Gauge to specific camber/caster/toe tools that installers need to correctly install our parts in this section. We also carry an extensive line of wheel service tools, strut and ball joint tools, plus more!

BRAKE & CV 177-180

We have a variety of consumables for the brake repair specialist. An extensive line of lathe inserts, drum tools, rotor silencers along with CV Boots and accessories.

Lathe Inserts/Drum Tools, and Rotor Silencers.....	177-178
Brake Tools, Radial Run-Out Gauges.....	179
CV Boots, Tools and Accessories.....	180

SPC GEAR & INDEXES..... 181-188

Check out our AlignGuide™ app along with our gear - shirts, hats, gloves and more, along with banners and stickers for your shop or vehicle. Quickly find what your need in our numerical index.

SPC Gear.....	181-184
Numerical Index/Retail Pricing.....	185-188

Applications

Alignment Parts

Heavy Duty

OE Replacement

Racing/Builders

Tools

Brake and CV

Gear/Index

HOW TO USE

The Alignment Sourcebook™

This Sourcebook has been designed with you in mind. Each section has tabs that allow you to quickly flip to the section you need without having to look through the entire Sourcebook. But it is a good idea to review the entire Sourcebook to check out new products and solutions for all your alignment needs.

Each new product is marked with our "NEW" logo for instant identification (shown at right). These new products are on the cutting edge of alignment technology.

You can look up the part you need in two ways:

- 1** If you are looking for a specific part for a specific vehicle, check for the vehicle make and model in the Applications Section starting on page 7.
- 2** If you know the part number of the part you need, the numerical index starts on page 185. Look there first.



At Specialty Products Company our goal is to assist you in every way to make car and truck alignment fast, accurate and profitable. We are committed to finding accurate, easily installed solutions to automotive driving and handling problems. Our products include excellent service and industry leading technical support.

THIS TOTAL WHEEL ALIGNMENT SOURCEBOOK™ WILL ASSIST YOU IN MAKING THE CORRECT RECOMMENDATIONS TO YOUR CUSTOMERS. THE SOURCEBOOK CONTAINS EVERYTHING NEEDED TO DETERMINE ESTIMATES AND RECOMMENDATIONS.

HOW TO SELL

Proper Alignment

- 1** When a set of new tires are installed or suspension parts changed, discuss frequency and need for total wheel alignment. Explain unusual tire wear or handling problems.
- 2** To determine the type of alignment required, refer to the Application section (pages 7-70) in this Sourcebook. Also refer to this section for the correct selection of original equipment and aftermarket replacement parts available from Specialty Products.
- 3** Use your Sourcebook and a showroom tire to explain tire wearing and control angles.
- 4** Explain to the customer the benefits of 4 Wheel and Thrust Wheel Alignments:

- Prolong Tire Life
- Improve Handling
- Minimize Premature Wear of Suspension Parts
- Help Eliminate "Pulls"
- Increase Fuel Mileage

- 5** **Ask for the sale.** Your customer will appreciate the benefits.

THE PROPER WHEEL ALIGNMENT SAVES THE CUSTOMER MONEY AND INCREASES CUSTOMER SATISFACTION BY DOING THE JOB RIGHT THE FIRST TIME.



Our "NEW" logo throughout this Sourcebook highlights the latest in alignment technology and applications.

SPC'S "TECH BOX"



Check out a quick overview of the part in our Tech Box. Alignment change, quantity in kit, and all the applications the part fits are in one easy-to-use spot.

AlignGuide™, by Specialty Products Company, provides manufacturers' alignment specifications for makes and models since 1985 as well as information on SPC's alignment parts and tools. See more on page 181.



TOOL ICON

When you see our 'Wrench' next to a part it means there is a special tool available to assist you in the installation of the part



INTERESTED IN ALIGNMENT TRAINING? SPC HAS THE OPTIONS YOU NEED!

If you want to stay competitive in today's high-tech automotive aftermarket Specialty Products Company has the comprehensive Alignment Training Program for you. With Hands-On Alignment Training and Online Training we can help you stay competitive with relevant technical training.

UPDATED - SPC FACTORY TRAINING

Basic Hands On Instructor Led Alignment Training

This 3-day Basic Alignment course is designed for entry level technicians who are new to vehicle alignment concepts and procedures. The course consists of presentations and demonstrations along with extensive hands-on training. Training consists of 40% classroom and 60% shop instruction.

Advanced Hands On Instructor Led Alignment Training

This 2-day Advanced Alignment course is designed for the technician who has been working with vehicle alignments for at least a year. The completion of the Basic Alignment Course is highly recommended. This course consists of presentations and demonstrations that include 60% classroom and 40% hands-on instruction.

SAVE - Combine both training options in one week!

ONLINE TRAINING

Specialty Products is the world leader in alignment products. We are passionate about suspensions and education. Using our online learning program, alignment techs and shop owners can further their knowledge of alignment theory and get the tools to put that knowledge into practical application. These training courses were developed by our ASE Master Certified technician, who also develops our in-house training. Get comprehensive training in the changing alignment field on your schedule. Available in an interactive online class format, this training will take you from basic alignment angle descriptions, to vehicle specific applications that you see weekly in your shop.

FIELD TRAINING

To stay competitive and profitable in the competitive alignment field you must recognize the need for on going training to enable you to diagnose and align vehicles correctly the first time! Technicians now require updated information on lowered and lifted, as well as vehicles equipped with SAS systems. Our field clinics cover it all in a fast-paced, fact-filled environment. Contact your local warehouse or distributor to request field training in your area.

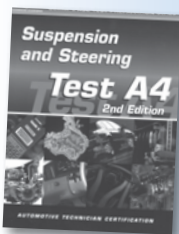

85560

ASE PREP BOOK

Get ready for the ASE A4 Suspension

and Steering Test with this comprehensive prep book.

ALignment TERMS

Applications

Alignment Parts

Heavy Duty

OE Replacement

Racing/Builders

Tools

Brake and CV

Gear/Index

Caster

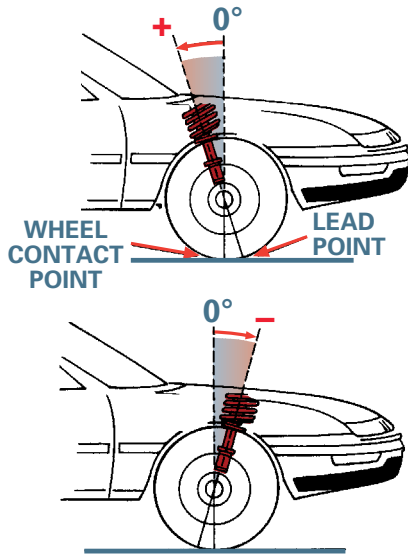

DEFINITION: The forward or backward tilt of the upper ball joint, or top of the strut, relative to the lower ball joint.

PURPOSE: Caster affects steering stability and steering wheel returnability.

METHODS OF CASTER ADJUSTMENT: (1) Shims (2) Cams (3) Slotted Frame (4) Strut Rod (5) Strut Rotation (6) Cradle Movement (7) Offset Ball Joint (8) Sliding Ball Joint

0 CASTER: The upper ball joint or top strut bearing and lower ball joint are in the same plane as viewed from the side of the vehicle.

POSITIVE CASTER: The upper ball joint or top strut bearing is toward the rear of the vehicle in relation to the lower ball joint as viewed from the side of the vehicle.

NEGATIVE CASTER: The upper ball joint or top strut bearing is toward the front of the vehicle in relation to the lower ball joint as viewed from the side of the vehicle.

SYMPTOMS OF NEG. CASTER: (1) Steering wheel shows lack of "returnability" after a turn. (2) Steering is touchy at high speed (wander and weave).

Effect: Vehicle pulls to the side with the Lowest Caster.

Example: Left front set at 1/2° positive Caster, right front set at 1-1/2° positive Caster. This vehicle will pull to the left.

Camber

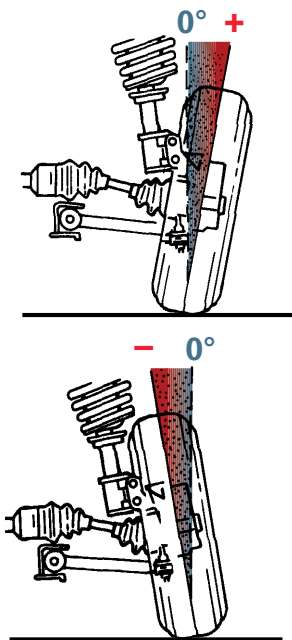

DEFINITION: Inward or outward tilt of the top of the wheel.

PURPOSE: Adjustment centers the vehicle's load on the tire, eliminating pull. Proper adjustment reduces camber tire wear and pulling.

METHODS OF CAMBER ADJUSTMENT: (1) Shim (2) Cams (3) Slotted Frame (4) Strut Rotation (5) Wedges (6) Ball Joint Rotation (7) Offset Bearing Plates (8) Cam Bolts (9) Eccentrics (10) Offset Ball Joints (Offset Bushings)

0 CAMBER: When wheel and tire assembly are in exact vertical position.

POSITIVE CAMBER: When the top of the wheel and tire assembly is tilted out, or away from the engine.

TOO MUCH POS. CAMBER CAUSES: (1) Wear on the outside of the tire. (2) Extra wear on the suspension parts with positive camber. (3) The vehicle will pull to the side with the **most positive** camber.

NEGATIVE CAMBER: The top of the wheel and tire assembly is tilted in, toward the engine.

TOO MUCH NEG. CAMBER CAUSES: (1) Wear on the inside portion of the tire. (2) Extra wear on the suspension parts with negative camber (3) The vehicle will pull to the side with the **most positive** camber.

UNEQUAL CAMBER From side to side causes: (1) Vehicle to pull to the side with the more positive camber.

Example: Left front set at 1° positive. Right front set at 1/2°. This vehicle may pull left.

Setback

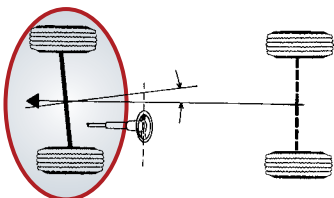

DEFINITION: One wheel set back further than the other.

SETBACK IS CAUSED BY: (1) Manufacturer (sometimes they build them this way). (2) Collision.

Normally up to .5" Setback will cause no problems other than steering wheel misalignment when using some types of alignment equipment.

DEFINITION:	The difference between leading edges and trailing edges of the front of the wheel & tire assembly, measured at spindle height.
PURPOSE:	Minimize tire wear and rolling friction.
FRONT TOE ADJUSTMENTS:	(1) Tie Rod Adjusters
REAR TOE:	(1) Manufacturer's built-in adjuster (2) Cams (3) Cam bolts (4) Slots (5) Eccentrics (Offset Bushings) (6) Shims (7) EZ Arms XR™
0 TOE:	Distances across the front and trailing edges of the wheel and tire assemblies are equal.
TOE IN (+):	Distance across the front edges of the wheel and tire assemblies is less than across the trailing edges.
TOO MUCH TOE IN CAUSES:	(1) Rapid wear on outside edge of tire. (a) On radial tires too much Toe In resembles pos. camber wear. (b) Wear patterns are saw-toothed or scuffed . (c) Feeling sharp edges when rubbing your hand across the tire tread, from inside toward outside , reveals excessive Toe In . (2) Steering instability (extreme). (a) Wander (b) Shimmy
TOE OUT (-):	Distance across the front edges of the wheel and tire assemblies is wider than the trailing edges.
TOO MUCH TOE OUT CAUSES:	(1) Rapid tire wear-inside edge of tire. (a) On radial tires too much Toe Out resembles neg. Camber wear. (b) Wear pattern is saw-toothed or scuffing . (c) Feeling sharp edges when rubbing your hand across the tire tread, from outside to inside, reveals excessive Toe Out . (2) Steering instability (extreme). (a) Wander (b) Shimmy

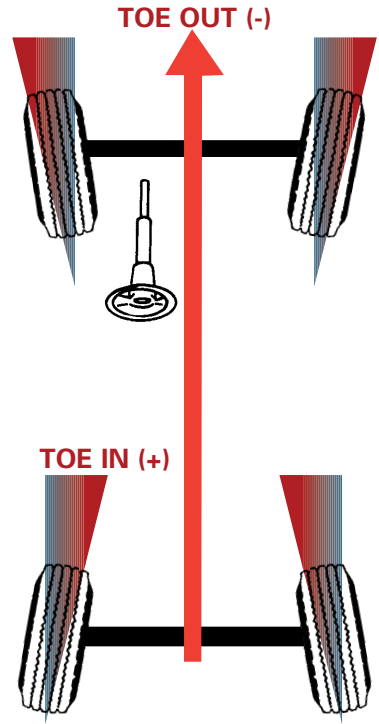

Toe

DEFINITION:	The relative position of the front wheels during a turn.
REFERRED TO AS:	(1) Toe out on turns (2) Turning radius
PURPOSE:	To prevent tire side slip. To prevent excessive tire wear. To prevent tire squeal on turns.
DIAGNOSE FOR BENT PARTS:	If readings differ more than 1-1/2° from specifications on most vehicles, and the tires squeal when cornering, the vehicle may have a bent steering arm. Most Turning Angles are non-adjustable angles but can be corrected by replacing bent parts.

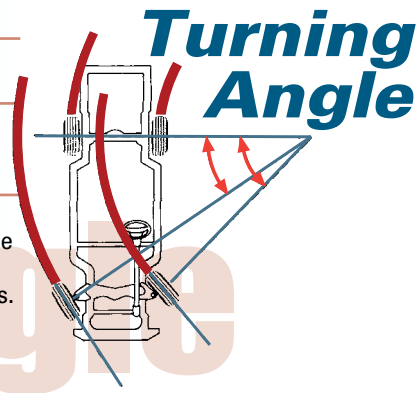

Turning Angle

DEFINITION:	The direction the rear wheels are positioned in reference to the vehicle centerline.
REAR WHEEL THRUST WILL CAUSE:	(1) Tire wear (2) Steering wheel misalignment (3) Car pulls (4) "Dog Tracking" (5) Crooked steering wheel
THRUST CAN BE CORRECTED BY:	(1) Adjustment of built in toe adjuster. (2) Installing tapered shims between spindle and hub. (3) Cams or other aftermarket adjusters. (4) Specialty Products Thrust Plate (#63020, #63030 Kits - page 85).

Thrust Angle

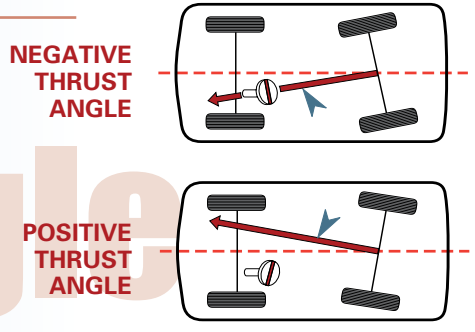

Thrust Angle

S.A.I.

I.A.

Scrub Radius

DEFINITION OF S.A.I. (Steering Axis Inclination):

The angle between a true vertical line starting at the center of the tire at the road contact point and a line drawn through the center of the strut (or upper ball joint) and lower ball joint. S.A.I. is a non-adjustable angle on most vehicles. **OR...**

The angle formed by the intersection of a line drawn through the upper and lower suspension mounting points (as viewed from the front of the vehicle) and true vertical. **NOTE:** A bent lower control arm can also change S.A.I. The strut suspension on a unibody vehicle has many variables and locating the damaged part may be difficult.

DEFINITION OF I.A. (Included Angle):

S.A.I. angle plus actual camber (positive) or minus actual camber (negative) is the included angle. When camber is positive, add it to the S.A.I. angle. If camber is negative, subtract it from the S.A.I. angle. This angle is used as a diagnostic tool to determine if structural misalignment is present or suspension parts are bent.

DEFINITION OF SCRUB RADIUS:

When compared at ground level, the distance between the S.A.I. line (drawn through the steering pivots) and the centerline of the tire tread is called the Scrub Radius. When this line is toward the inside of the tread, the vehicle is said to have Positive Scrub Radius. When the line is toward the outside of the tire tread, the vehicle is said to have Negative Scrub Radius.

NOTE: Negative Scrub Radius can be found on some FWD MacPherson Strut vehicles.

PURPOSE:

Directional Control Stability • Steering Wheel Returnability • Vehicle Load Placement
S.A.I., I.A. and Camber can be used to locate areas of the strut system on unibodies which may have damaged or misaligned parts. I.A. (Included Angle) is used to determine if there is a damaged spindle or strut tube. The S.A.I. (Steering Axis Inclination) is used to determine if the unibody is misaligned.



S.A.I. MAGNET

This informative magnet trouble shooting guide sticks on the installer's tool box. Find out more on page 183.

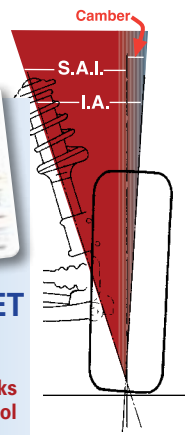

S.A.I. Diagnostic Guide

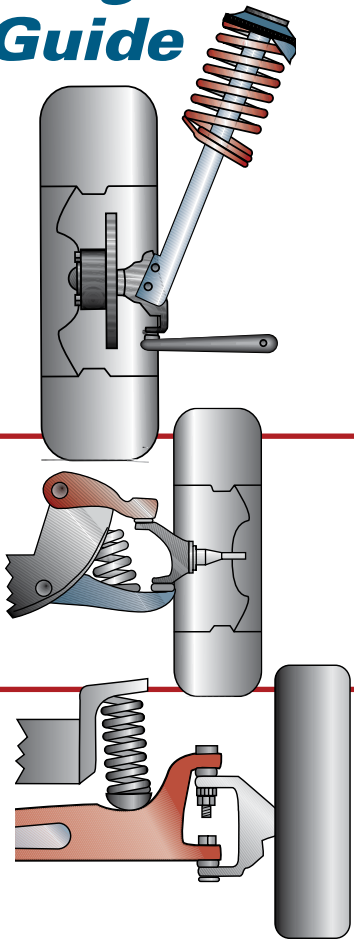

MACPHERSON STRUT SUSPENSIONS

SAI	CAMBER	INC. ANGLE	PROBABLE PROBLEM AREA
Within Spec	Less than Spec	Less than Spec	Bent Spindle Assembly and/or Bent Strut.
Within Spec	Greater than Spec	Greater than Spec	Bent Spindle Assembly and/or Bent Strut.
Less than Spec	Greater than Spec	Within Spec	Bent Control Arm, or Top of Strut Tower Pushed Outward, or Mis-Aligned Engine Cradle.
Greater than Spec	Less than Spec	Within Spec	Top of Strut Tower Pushed In, or Engine Cradle Mis-Aligned.
Less than Spec	Greater than Spec	Greater than Spec	Bent Control Arm, or Top of Strut Tower Pushed Out PLUS Bent Spindle Assembly and/or Bent Strut.
Less than Spec	Greater than Spec	Less than Spec	Bent Control Arm, or Top of Strut Tower Pushed Out PLUS Bent Spindle Assembly and/or Bent Strut.
Less than Spec	Less than Spec	Less than Spec	Bent Control Arm, or Top of Strut Tower Pushed Out PLUS Bent Spindle Assembly

SHORT/LONG ARM SUSPENSIONS

SAI	CAMBER	INC. ANGLE	PROBABLE PROBLEM AREA
Within Spec	Less than Spec	Less than Spec	Bent Spindle Assembly
Less than Spec	Greater than Spec	Within Spec	Bent Lower Control Arm or Bent Frame
Greater than Spec	Less than Spec	Within Spec	Bent Upper Control Arm or Bent Frame
Less than Spec	Greater than Spec	Greater than Spec	Bent Lower Control Arm, or Bent Spindle and/or Bent Strut.

FORD TWIN "I-BEAM" SUSPENSIONS

SAI	CAMBER	INC. ANGLE	PROBABLE PROBLEM AREA
Within Spec	Greater than Spec	Greater than Spec	Bent Spindle Assembly
Greater than Spec	Less than Spec	Within Spec	Bent "I" Beam
Less than Spec	Greater than Spec	Within Spec	Bent "I" Beam
Less than Spec	Greater than Spec	Greater than Spec	Bent "I" Beam & Bent Spindle Assembly

CAR/MINI-VAN/SUV/TRUCK APPLICATIONS

ACURA			REAR			Thrust Plate	FRONT		
Model/Body Style	Year	Drive Type	CAMBER/TOOL	TOE/TOOL	Page		CASTER/TOOL	CAMBER/TOOL	Page
CL	01-04	FWD	67090/37995	OEMA	88/164	N/A	67125/40920 67320(8)/40920	89/165 92/165	
Stock Replacement Part			67075		153		67075	153	
CL	97-99	FWD	67065/37995 67265(8)/37995	OEMA	87/164 90/164	84690, 84695	67145/40920 67340(8)/40920	126,89/165 92/165	
CL	97-99	FWD	67065/37995 67265(8)/37995	OEMA	87/164 90/164	84690, 84695	67125/40920 67320(8)/40920	126,89/165 92/165	
CSX	06-11	FWD	67465/72509,75980 67466 67475	OEMA/ 87560	94/169,171 94/174 97	N/A	81260	117	
EL	03-05	FWD	67230 69300(22)/69330(14)	OEMA	90 102/168	N/A	81280	117	
EL	01-02	FWD	67230 69300(22)/69330(14)	OEMA	90 102/168	N/A	81280	117	
EL	97-00	FWD	67030 69100(22)	OEMA 69250 69450	87 WB/WB 102	62010	62010 67135/40920 67330(8)/40920	WB 89/165 92/165	
Stock Replacement Part			67245		153				
Integra	94-01	FWD	67030 69200(23)	OEMA 69250 69450	87 WB/WB 102	N/A	67135/40920 67330(8)/40920	89/165 92/165	
Integra	90-93	FWD	67030 69200(22)	OEMA 69250 69450	87 WB/WB 102	N/A	67135/40920 67330(8)/40920	89/165 92/165	
Stock Replacement Part							67245	153	
Integra	86-89	FWD	N/A	N/A		N/A	N/A		
ILX	13-20	FWD	67465/72509,75980 67466 67475	OEMA/ 87560	94/169,171 94/174 97	N/A	81280	117	
Legend	91-96	FWD	N/A	OEMA		N/A	67135/40920 67330(8)/40920	89/165 92/165	
Stock Replacement Part							67245	153	
Legend	86-90	FWD	N/A	OEMA		OEMA	N/A		
MDX	14-20	FWD/AWD	23450/37995	OEMA	77/164	N/A	N/A		
MDX	07-13	AWD	67570/37995	OEMA	98/164	N/A	81295	117	
MDX	01-06	AWD	67290/37995	OEMA	91/164	N/A	81280	117	
<i>67289, 67291, 67292 adjust setback</i>									
NSX	17-20	RWD/AWD	OEMA	OEMA		N/A	OEMA		
NSX	91-06	RWD	OEMA	OEMA		OEMA	OEMA		
RDX	19-20	FWD/AWD	N/A	OEMA		N/A	N/A		
RDX	07-18	FWD/AWD	67595	OEMA 67595 67596	99 99 99	N/A	81280	117	
RL	05-13	AWD	N/A	OEMA		N/A	N/A		
RL	96-04	FWD	67090/37995	OEMA	88/164	N/A	67135/40920 67330(8)/40920	89/165 92/165	
Stock Replacement Part							67245	153	
RLX	14-20	FWD/AWD	N/A	OEMA		N/A	N/A		
RSX	02-02	FWD	67230 69400(22)/69330(14)	OEMA	90 102/168	N/A	81260	117	
<i>VIN 2C003183 or earlier</i>									
Stock Replacement Part			69400		102		67245	153	
RSX	02-06	FWD	67230 69400(22)/69330(14)	OEMA	90 102/168	N/A	81280	117	
<i>VIN 2C003184 or later</i>									
Stock Replacement Part			69400		102				
SLX	96-00	RWD/4WD	N/A	N/A		47700(*)	47700(*)	84	

CAR/MINI-VAN/SUV/TRUCK APPLICATIONS

ACURA-cont.

ACURA-cont.			REAR			FRONT			
Model/Body Style	Year	Drive Type	CAMBER/TOOL	TOE/TOOL	Page	Thrust Plate	CASTER/TOOL	CAMBER/TOOL	Page
TL (Inc. SH-AWD) <i>*67550 or 67555 must be used w/67540, 67545, 67550 to adjust setback</i>	09-14	FWD/AWD	67540/ 74920 67545(12)/ 74920 67560/ 74920	OEMA 67540/ 74920 67550/ 74920 67555/ 74920 67560/ 74920 67565/ 74920	97/ 169 97/ 169 97/ 169 97/ 169 97/ 169		N/A	67135/40920 67330(8)/ 40920	89/ 165 92/ 165
TL (Inc. Type S)	04-08	FWD	67095/ 37995	OEMA 67295	88/ 164 91		N/A	67125/40920 67320(8)/ 40920	89/ 165 92/ 165
Stock Replacement Part			67075		153			67075	153
TL (Inc. Type S)	99-03	FWD	67090/ 37995	OEMA 67295	88/ 164 91		84690, 84695	67125/40920 67320(8)/ 40920	89/ 165 92/ 165
Stock Replacement Part			67075		153			67075	153
TL 2.5 (Inc. Type S)	96-98	FWD	67065/37995 67265(8)/ 37995	OEMA	87/ 164 90/ 164		84690, 84695	67125/40920 67320(8)/ 40920	89/ 165 92/ 165
Stock Replacement Part			67075		153				
TL 3.2 (Inc. Type S)	96-98	FWD	67065/37995 67265(8)/ 37995	OEMA	87/ 164 87/ 164		84690, 84695	67135/40920 67330(8)/ 40920	89/ 165 92/ 165
Stock Replacement Part			67075		153			67075	153
TLX <i>*67550 or 67555 must be used w/67540, 67545, 67550 to adjust setback</i>	15-20	AWD	67540/ 74920 67545(12)/ 74920 67560/ 74920	OEMA 67540/ 74920 67550/ 74920 67555/ 74920 67560/ 74920 67565/ 74920	97/ 169 97/ 169 97/ 169 97/ 169 97/ 169		N/A	67135/40920 67330(8)/ 40920	89/ 165 92/ 165
TLX	15-20	FWD	67560/ 74920	OEMA 67560/ 85130,74920 67565/ 85130,74920	98/ 169 98/ 173,169 98/ 173,169		N/A	N/A	
TSX <i>*67550 or 67555 must be used w/67540, 67545, 67550 to adjust setback</i>	09-14	FWD	67540/ 74920 67545(12)/ 74920 67560/ 74920	OEMA 67540/ 74920 67550/ 74920 67555/ 74920 67560/ 74920 67565/ 74920	97/ 169 97/ 169 97/ 169 97/ 169 97/ 169		N/A	67135/40920 67330(8)/ 40920	89/ 165 92/ 165
TSX <i>*67289, 675292, 67293 adjust setback</i>	04-08	FWD	67289/ 37995 67290/ 37995 67291/ 37995	OEMA 67289/ 37995 67292 67293 67295	91/ 164 91/ 164 91/ 164 91 91		N/A	67125/40920 67320(8)/ 40920	89/ 165 92/ 165
Stock Replacement Part			67075		153			67075	153
Vigor	92-94	FWD	67065/37995 67265(8)/ 37995	OEMA	87/ 164 87/ 164		84690, 84695	67165/40920 67360(8)/ 40920	89/ 165 92/ 165
Stock Replacement Part			67075		153			67075	153
ZDX	10-13	AWD	67570/ 37995	OEMA	98/ 164		N/A	81295	117

ALFA ROMEO

4C	14-20	RWD	N/A	OEMA			N/A	N/A	
Giulia	17-20	RWD/AWD	N/A	OEMA			N/A	N/A	
Stelvio	18-20	RWD/AWD	OEMA	OEMA			N/A	N/A	

AUDI

100	87-96	FWD	N/A	N/A			N/A	OEMA	
100 - Quattro	87-96	AWD	OEMA	OEMA			N/A	OEMA	
100	70-77	FWD	75400(1)	75400(1)	116,116		N/A	OEMA	
200	87-96	FWD	N/A	N/A			N/A	OEMA	
200 - Quattro	87-96	AWD	OEMA	OEMA			N/A	OEMA	
4000 <i>75200 must be used w/#10408</i>	80-87	FWD	75200(1)+10408	75200(1)+10408	116,73		N/A	OEMA	
4000 - Quattro	80-87	AWD	OEMA	OEMA			N/A	OEMA	
5000 - Quattro	86-88	AWD	OEMA	OEMA			N/A	OEMA	
5000 <i>75200 must be used w/#10408</i>	80-86	FWD	75400(1)+10408	75400(1)+10408	116,73		N/A	OEMA	

Applications

Alignment Parts

Heavy Duty

OE Replacement

Racing/Builders

Tools

Brake and CV

Gear/Index

CAR/MINI-VAN/SUV/TRUCK APPLICATIONS

AUDI-cont.			REAR			Thrust Plate	FRONT		
Model/Body Style	Year	Drive Type	CAMBER/TOOL	TOE/TOOL	Page		CASTER/TOOL	CAMBER/TOOL	Page
80	88-92	FWD	N/A	N/A		N/A	OEMA		
80 Quattro	88-92	AWD	OEMA	OEMA		N/A	OEMA		
90	88-95	FWD	N/A	N/A		N/A	OEMA		
90 Quattro	88-95	AWD	OEMA	OEMA		N/A	OEMA		
A3	06-20	FWD/AWD	OEMA 81335	OEMA	118	N/A	N/A		
Allroad A4 B9	17-20	AWD	OEMA	OEMA		81383 81381, 81382 81388	81383 81381, 81382 81388	119,119 119,119 119,119	
Stock Replacement Part						21045		152	
Allroad A4 B8	13-16	AWD	OEMA/ 87570	OEMA	174	81363 81361, 81362 81368	81363 81361, 81362 81368	119,119 119,119 119,119	
Stock Replacement Part						21040		152	
A4 (B9)	17-20	FWD/AWD	OEMA	OEMA		81383 81381, 81382 81388	81383 81381, 81382 81388	119,119 119,119 119,119	
Stock Replacement Part						21045		152	
A4 (B8)	09-16	FWD/AWD	OEMA/ 87570	OEMA	174	81363 81361, 81362 81368	81363 81361, 81362 81368	119,119 119,119 119,119	
Stock Replacement Part						21040		152	
A4 (B5/B6/B7)	98-08	FWD/AWD	OEMA	OEMA 81520 (02-08 only)	120	81353 81351, 81352 81358	81353 81351, 81352 81358	119,119 119,119 119,119	
Stock Replacement Part						21040		152	
A4 (B5)	96-97	FWD/AWD	N/A	OEMA		N/A	N/A		
A5 (B9)	18-20	FWD/AWD	OEMA	OEMA		81383 81381, 81382 81388	81383 81381, 81382 81388	119,119 119,119 119,119	
Stock Replacement Part						21045		152	
A5 (B8)	09-17	FWD/AWD	OEMA/ 87570	OEMA	174	81363 81361, 81362 81368	81363 81361, 81362 81368	119,119 119,119 119,119	
Stock Replacement Part						21040		152	
A5 (B7)	07-08	FWD/AWD	OEMA	OEMA		81353 81351, 81352 81358	81353 81351, 81352 81358	119,119 119,119 119,119	
Stock Replacement Part						21040		152	
Allroad A6 (C5)	99-05	AWD	OEMA	OEMA		81353 81351, 81352 81358	81353 81351, 81352 81358	119,119 119,119 119,119	
Stock Replacement Part						21040		152	
A6 (C8)	19-20	FWD/AWD	OEMA	OEMA		N/A	N/A		
A6 (C7)	12-18	FWD/AWD	OEMA/ 87570	OEMA	174	81363 81361, 81362 81368	81363 81361, 81362 81368	119,119 119,119 119,119	
Stock Replacement Part						21040		152	
A6 (C6)	05-11	FWD/AWD	OEMA	OEMA		81373 81371, 81372 81378	81373 81371, 81372 81378	119,119 119,119 119,119	
Stock Replacement Part						21040		152	
A6 (C5)	98-04	FWD/AWD	N/A	N/A		81353 81351, 81352 81358	81353 81351, 81352 81358	119,119 119,119 119,119	
Stock Replacement Part						21040		152	
A6	95-97	FWD	N/A	N/A		N/A	N/A		

CAR/MINI-VAN/SUV/TRUCK APPLICATIONS

AUDI-cont.

Model/Body Style			REAR			FRONT		
Year	Drive Type	CAMBER/TOOL	TOE/TOOL	Page	Thrust Plate	CASTER/TOOL	CAMBER/TOOL	Page
A6Quattro	95-97	AWD	OEMA	OEMA		N/A	N/A	
A7	19-20	FWD/AWD	OEMA	OEMA		N/A	N/A	
A7 (C7)	12-18	FWD/AWD	OEMA/87570	OEMA	174	81363 81361, 81362 81368	81363 81361, 81362 81368	119,119 119,119 119,119
Stock Replacement Part						21040		152
A8 (D5)	19-20	FWD/AWD	OEMA	OEMA		N/A	N/A	
A8 (D4)	11-18	FWD/AWD	OEMA/87570	OEMA	174	N/A	N/A	
A8 (D3)	04-10	FWD/AWD	OEMA	OEMA		81373 81371, 81762 81378	81373 81371, 81372 81378	119,119 119,119 119,119
Stock Replacement Part						21040		152
A8 (D2)	96-03	FWD/AWD	OEMA	OEMA		N/A	N/A	
Cabriolet	94-98	FWD	N/A	N/A		N/A	OEMA 81260	117
e-tron	19-20	AWD	OEMA	OEMA		N/A	N/A	
Fox	75-79	FWD	N/A	N/A		N/A	OEMA	
Quattro	82-86	AWD	OEMA	OEMA		N/A	OEMA	
Q3	15-18	FWD/AWD	OEMA 81335	OEMA	118	N/A	N/A	
Q5 (B9)	18-20	FWD/AWD	OEMA	OEMA		N/A	N/A	
Q5 (B8)	09-17	FWD/AWD	OEMA	OEMA		81363 81361, 81362 81368	81363 81361, 81362 81368	119,119 119,119 119,119
Stock Replacement Part						21040		152
Q7	07-20	AWD	OEMA	OEMA		N/A	N/A	
Q8	19-20	AWD	OEMA	OEMA		N/A	N/A	
RS3	17-20	AWD	OEMA 81335	OEMA	118	N/A	N/A	
RS4 (B7)	07-08	AWD	OEMA	OEMA 81520	120	81353 81351, 81352 81358	81353 81351, 81352 81358	119,119 119,119 119,119
Stock Replacement Part						21040		152
RS5 (B9)	18-20	AWD	OEMA	OEMA		N/A	N/A	
Stock Replacement Part						21040		152
RS5 (B8)	13-17	AWD	OEMA	OEMA		81363 81361, 81362 81368	81363 81361, 81362 81368	119,119 119,119 119,119
Stock Replacement Part						21040		152
RS6 (C5)	03-03	AWD	N/A	N/A		81353 81351, 81352 81358	81353 81351, 81352 81358	119,119 119,119 119,119
Stock Replacement Part						21040		152
RS7 (C7)	14-18	AWD	OEMA	OEMA		81363 81361, 81362 81368	81363 81361, 81362 81368	119,119 119,119 119,119
Stock Replacement Part						21040		152
SQ5 (B9)	18-20	AWD	OEMA	OEMA		N/A	N/A	
SQ5 (B8)	13-17	AWD	OEMA	OEMA		81363 81361, 81362 81368	81363 81361, 81362 81368	119,119 119,119 119,119
Stock Replacement Part						21040		152
S3	15-20	FWD/AWD	OEMA 81335	OEMA	118	N/A	N/A	
S4 (B9)	17-20	AWD	OEMA	OEMA		81383 81381, 81382 81388	81383 81381, 81382 81388	119,119 119,119 119,119
Stock Replacement Part						21045		152
S4 (B8)	09-16	AWD	OEMA/87570	OEMA	174	81363 81361, 81362 81368	81363 81361, 81362 81368	119,119 119,119 119,119
Stock Replacement Part						21040		152

Applications

Alignment Parts

Heavy Duty

OE Replacement

Racing/Builders

Tools

Brake and CV

Gear/Index

CAR/MINI-VAN/SUV/TRUCK APPLICATIONS

AUDI-cont.			REAR			Thrust Plate	FRONT		
Model/Body Style	Year	Drive Type	CAMBER/TOOL	TOE/TOOL	Page		CASTER/TOOL	CAMBER/TOOL	Page
S4 (B5/B6/B7)	98-08	AWD	OEMA	OEMA 81520 (02-08 only)	120	81353 81351, 81352 81358	81353 81351, 81352 81358	119,119 119,119 119,119	
Stock Replacement Part						21040		152	
S5 (B9)	18-20	AWD	OEMA	OEMA		81383 81381, 81382 81388	81383 81381, 81382 81388	119,119 119,119 119,119	
Stock Replacement Part						21045		152	
S5 (B8)	09-17	AWD	OEMA	OEMA		81363 81361, 81362 81368	81363 81361, 81362 81368	119,119 119,119 119,119	
Stock Replacement Part						21040		152	
S5 (B7)	07-08	AWD	OEMA	OEMA		81353 81351, 81352 81358	81353 81351, 81352 81358	119,119 119,119 119,119	
Stock Replacement Part						21040		152	
S6 (C7)	13-18	AWD	OEMA/87570	OEMA	174	81363 81361, 81362 81368	81363 81361, 81362 81368	119,119 119,119 119,119	
Stock Replacement Part						21040		152	
S6 (C6)	07-11	AWD	OEMA	OEMA		81373 81371, 81762 81378	81373 81371, 81372 81378	119,119 119,119 119,119	
Stock Replacement Part						21040		152	
S6 (C5)	01-02	AWD	N/A	N/A		81353 81351, 81352 81358	81353 81351, 81352 81358	119,119 119,119 119,119	
Stock Replacement Part						21040		152	
S7 (C7)	12-18	FWD/AWD	OEMA	OEMA		81363 81361, 81362 81368	81363 81361, 81362 81368	119,119 119,119 119,119	
Stock Replacement Part						21040		152	
S8 (D4)	11-18	AWD	OEMA/87570	OEMA	174	N/A	N/A		
S8 (D3)	04-10	AWD	OEMA	OEMA		81373 81371, 81762 81378	81373 81371 , 81372 81378	119,119 119,119 119,119	
Stock Replacement Part						21040		152	
S8(D2)	96-03	AWD	OEMA	OEMA		N/A	N/A		
TT	08-20	FWD/AWD	OEMA 81335	OEMA	118	N/A	N/A		
TT	00-06	FWD	71500(*) (1)/87530	71500(*) (1)/87530	103/174	81340	81340	119/119	
TT Quattro	00-06	AWD	N/A	OEMA		81340	81340	119/119	
BENTLEY									
Continental	04-12	AWD	OEMA	OEMA		81373 81371, 81762 81378	81373 81371, 81372 81378	119/119 119/119 119/119	
Stock Replacement Part						21040		152	
BMW									
1 Series 1M Coupe	11-12	RWD	OEMA 67105	OEMA	88	72190/ 72095	OEMA 72190/ 72095	108/ 169 108/ 169	
1 Series (E81 E82 E87 E88)	08-13	AWD	OEMA 67105	OEMA	88	72070/ 72095	OEMA 72070/ 72095	107/ 169 107/ 169	
1 Series (E81 E82 E87 E88)	08-13	RWD	OEMA 67105	OEMA	88	72190/ 72095	OEMA 72190/ 72095	108/ 169 108/ 169	
2 Series (F2)2	14-20	RWD/AWD	OEMA	OEMA		N/A	OEMA		

Applications

CAR/MINI-VAN/SUV/TRUCK APPLICATIONS

BMW-cont.			REAR			Thrust Plate	FRONT		
<i>Model/Body Style</i>	<i>Year</i>	<i>Drive Type</i>	<i>CAMBER/TOOL</i>	<i>TOE/TOOL</i>	<i>Page</i>		<i>CASTER/TOOL</i>	<i>CAMBER/TOOL</i>	<i>Page</i>
3 Series Sedan (G20)	19-20	RWD/AWD	OEMA	OEMA			N/A	N/A	
3 Series Sedan and Wagon (F30/F31)	12-18	RWD/AWD	OEMA	OEMA			N/A	N/A	
3 Series Cpe. & Conv. (E92 E93)	07-13	AWD	OEMA 67105	OEMA	88		72070/ 72095	OEMA 72070/ 72095	107/ 169 107/ 169
3 Series Cpe. & Conv. (E92 E93)	07-13	RWD	OEMA 67105	OEMA	88		72190/ 72095	OEMA 72190/ 72095	108/ 169 108/ 169
3 Series M3	07-13	RWD	OEMA 67105	OEMA	88		N/A	OEMA	
3 Series Sedan & Wagon (E90 E91)	06-12	AWD	OEMA 67105	OEMA	88		72070/ 72095	OEMA 72070/ 72095	107/ 169 107/ 169
3 Series Sedan & Wagon (E90 E91)	06-12	RWD	OEMA 67105	OEMA	88		72190/ 72095	OEMA 72190/ 72095	108/ 169 108/ 169
3 Series Cpe. & Conv. (E46)	05-06	RWD/AWD	OEMA 67110 72110	OEMA/ 87565	174 89 107		72090/ 72095	OEMA 72090/ 72095	107/ 169 107/ 169
3 Series Sedan & Wagon (E46)	04-05	RWD/AWD	OEMA 67110 72110	OEMA/ 87565	174 89 107		72090/ 72095	OEMA 72090/ 72095	107/ 169 107/ 169
3 Series Cpe. & Conv. (E46)	00-04	RWD/AWD	OEMA 67110 72110	OEMA/ 87565	174 89 107		72080/ 72095	OEMA 72080/ 72095	107/ 169 107/ 169
3 Series M3 (E46)	00-06	RWD	OEMA 67110 72110	OEMA/ 87565	174 89 107		N/A	OEMA	
3 Series Sedan & Wagon (E46)	99-03	RWD/AWD	OEMA 67110 72110	OEMA/ 87565	174 89 107		72080/ 72095	OEMA 72080/ 72095	107/ 169 107/ 169
3 Series M Cpe./Rdstr. (E36)	96-02	RWD	N/A	N/A/ 87567	174		72070(10)/ 72095	72070(10)/ 72095	107,107 169,169
3 Series 318, 323, 325, 328, M3 (E36)	92-99	RWD	OEMA 67110 72110	OEMA/ 87567	174 89 107		72070(10)/ 72095	72070(10)/ 72095	107,107 169,169
3 Series 318Ti (E30)	92-99	RWD	N/A	N/A			72090/ 72095	72090/ 72095	107/ 169
3 Series (E30)	84-91	AWD	N/A	N/A			N/A	N/A	
3 Series (E30)	84-91	RWD	N/A	N/A			72065/ 72095	72065/ 72095	107/ 169
4 Series (F32)	14-20	RWD/AWD	OEMA	OEMA			N/A	N/A	
5 Series (G30 G31)	17-20	RWD/AWD	OEMA	OEMA			N/A	N/A	
5 Series (F10 F11)	10-16	RWD/AWD	OEMA	OEMA			N/A	N/A	
5 Series (E60 E61)	06-09	AWD	OEMA	OEMA			N/A	OEMA	
5 Series (E60 E61)	04-09	RWD	OEMA	OEMA			N/A	OEMA	
5 Series 525i 528i w/o EDC 528iT 530i (E39)	96-03	RWD	OEMA 72185/ 72509	OEMA 72185/ 72509	108/ 169		72080/ 72095	72080/ 72095	107/ 169
5 Series 528i w/EDC 540i 540iT M5 (E39)	96-04	RWD	OEMA 72185/ 72509	OEMA 72185/ 72509	108/ 169		72180/ 72095	72180/ 72095	108/ 169
5 Series (E23 E34)	87-95	RWD	N/A	N/A			N/A	N/A	
6 Series (F12 F13)	11-19	RWD/AWD	OEMA	OEMA			N/A	N/A	
6 Series (E63 E64)	04-10	RWD	OEMA 72185/ 72509	OEMA 72185/ 72509	108/ 169		N/A	N/A	
6 Series (E24)	80-89	RWD	N/A	N/A			N/A	N/A	
7 Series (G11 G12)	16-20	RWD/AWD	OEMA	OEMA			N/A	N/A	
7 Series (F01 F02 F03 F04)	09-15	RWD/AWD	OEMA	OEMA			N/A	N/A	
7 Series (E65 E66 E67 E68)	02-08	RWD	OEMA 72185/ 72509	OEMA 72185/ 72509	108/ 169		N/A	OEMA	
7 Series (E38)	95-01	RWD	OEMA	OEMA			N/A	N/A	
7 Series (E23 E32)	87-94	RWD	N/A	N/A			N/A	N/A	
8 Series Coupe (G15)	19-20	RWD/AWD	OEMA	OEMA			N/A	N/A	
8 Series Z8 Rdstr. (E52)	00-04	RWD	OEMA	OEMA			N/A	N/A	

Applications

Alignment Parts

Heavy Duty

OE Replacement

Racing/Builders

Tools

Brake and CV

Gear/Index

CAR/MINI-VAN/SUV/TRUCK APPLICATIONS

BMW-cont.			REAR			Thrust Plate	FRONT		
Model/Body Style	Year	Drive Type	CAMBER/TOOL	TOE/TOOL	Page		CASTER/TOOL	CAMBER/TOOL	Page
8 Series (E31)	90-99	RWD	N/A	N/A		N/A	N/A		
i3	14-20	FWD	OEMA	OEMA		N/A	N/A		
i8	14-20	AWD	OEMA	OEMA		N/A	N/A		
X1 (F48)	16-20	FWD/AWD	OEMA 67108	OEMA	88	N/A	OEMA		
X1 (E84)	12-15	RWD/AWD	OEMA	OEMA		N/A	N/A		
X2 (F39)	18-20	FWD/AWD	OEMA 67108	OEMA	88	N/A	OEMA		
X3 (G01)	18-20	AWD	OEMA	OEMA		N/A	N/A		
X3 (F25)	11-17	AWD	OEMA	OEMA		N/A	OEMA		
X3 (E83)	05-10	AWD	OEMA 67110 72110	OEMA	89 107	N/A	OEMA		
X4 (G02)	19-20	AWD	OEMA	OEMA		N/A	OEMA		
X4 (F26)	14-18	AWD	OEMA	OEMA		N/A	N/A		
X5 (G05)	19-20	AWD	OEMA	OEMA		N/A	N/A		
X5 (F15)	14-18	AWD	OEMA 72115/37995 72116, 72117	OEMA	107/ 164 107,107	N/A	OEMA		
Stock Replacement Part			12116, 12117		151,151				
X5 (E70)	07-13	AWD	OEMA 72115/37995 72116, 72117	OEMA	107/ 164 107,107	N/A	N/A		
Stock Replacement Part			12116, 12117		151,151				
X5 (E53)	00-06	AWD	OEMA	OEMA		N/A	81280 82120/ 85130	117 122/ 173	
X6 (F16)	15-19	AWD	OEMA 72115/37995 72116, 72117	OEMA	107/ 164 107,107	N/A	N/A		
Stock Replacement Part			12116, 12117		151,151				
X6 (E71)	08-14	AWD	OEMA 72115/37995 72116, 72117	OEMA	107/ 164 107,107	N/A	N/A		
Stock Replacement Part			12116, 12117		151,151				
X7 G07	19-20		OEMA	OEMA		N/A	N/A		
Z3 (E36)	96-02	RWD	N/A	N/A		72070(10)/ 72095	72070(10)/ 72095	107,107 169,169	
Z4 (E89)	09-16	RWD	OEMA 67110 72110	OEMA/ 87565	174 89 107	N/A	N/A		
Z4, Z4M (E85)	06-08	RWD	OEMA 67110 72110	OEMA/ 87565	174 89 107	N/A	OEMA		
Z4 (E85) Except M	03-08	RWD	OEMA 67110 72110	OEMA/ 87565	174 89 107	72090/ 72095	OEMA 72090/ 72095	107/ 169 107/ 169	
BUICK									
Allure	10-10	AWD	OEMA 82090	OEMA 82090/ 45938	120/ 167	N/A	OEMA 82130	122	
Allure w/ HiPer Strut	10-10	FWD	OEMA 82090	OEMA 82090/ 45938	120/ 167	N/A	OEMA 82130	122	
Allure w/o HiPer Strut	10-10	FWD	OEMA 82080	OEMA 82085	120,120	N/A	81250	117	
Allure	05-09	FWD	81260	OEMA	117	N/A	81260	117	
Apollo 'X' Body 94393, Pro Springs pg. 137 94001, upper ball joint pg. 157	73-74	RWD	N/A	N/A		47700(*) 97120 94374	47700(*) 97120	87 138,138 136	

Applications
Alignment Parts
Heavy Duty
OE Replacement
Racing/Builders
Tools
Brake and CV
Gear/Index

Applications

CAR/MINI-VAN/SUV/TRUCK APPLICATIONS

BUICK-cont.			REAR			FRONT			
Model/Body Style	Year	Drive Type	CAMBER/TOOL	TOE/TOOL	Page	Thrust Plate	CASTER/TOOL	CAMBER/TOOL	Page
Cascada	16-19	FWD	N/A	N/A			N/A	OEMA 82130	122
Century	97-05	FWD	81260	OEMA	117		N/A	81260	117
Century	82-96	FWD	75600(1) 75800(1)	75600(1) 75800(1)	116,116 116,116		N/A	82110/85130	121/173
Century 94006, upper ball joint pg. 157 94017, 1/2" ext upper ball joint pg. 157 94011, lower ball joint pg. 157	73-77	RWD	N/A	N/A			47700(*) 97130 94378	47700(*) 97130	84 138,138 136
Electra	85-90	FWD	81280 82120/85130	OEMA	117 122/173		OEMA	81280 82120/85130	117 122/173
Enclave	18-20	FWD/AWD	OEMA	OEMA			N/A	81250	117
Enclave	08-17	FWD/AWD	OEMA 82105, 82106	OEMA 82105, 82106	121,121		N/A	81280	117
Stock Replacement Part			15647		158				
Encore	13-20	AWD	N/A	N/A			N/A	81260	117
Encore	13-20	FWD	71050(*)	71050(*)	103,103		N/A	81260	117
Envision w/ HiPer Strut	16-20	FWD/AWD	OEMA	OEMA			N/A	OEMA 82130	122
Envision w/o HiPer Strut	16-20	FWD/AWD	OEMA	OEMA			N/A	81250	117
Estate Wagon	80-90	RWD	N/A	N/A			47700(*)	47700(*)	84
Grand National 94006, upper ball joint pg. 157 94017, 1/2" ext upper ball joint pg. 157 94011, lower ball joint pg. 157	82-87	RWD	N/A	N/A			47700(*) 97140 95336(22)	47700(*) 97140	84 138,138 136
GS 94391, Pro Springs (64-67) pg. 137 94392, Pro Springs (68-72) pg. 137 94001, upper ball joint pg. 157	64-72	RWD	N/A	N/A			47700(*) 97110 94344(22)	47700(*) 97110	84 138,138 136
LaCrosse	10-19	AWD	OEMA 82090	OEMA 82090/45938	120/167		N/A	OEMA 82130	122
LaCrosse w/ HiPer Strut	10-19	FWD	OEMA 82090	OEMA 82090/45938	120/167		N/A	OEMA 82130	122
LaCrosse w/o HiPer Strut	10-19	FWD	OEMA 82080	OEMA 82085	120		N/A	81250	117
LaCrosse	05-09	FWD	81260	OEMA	117		N/A	81260	117
LeSabre	00-06	FWD	75600(1) 75800(1)	OEMA 75600(1) 75800(1)	116 116,116 116		OEMA	81280 82120/85130	117 122/173
LeSabre	86-99	FWD	81280 82120/85130	OEMA	117 122/173		OEMA	81280 82120/85130	117 122/173
LeSabre 94006, upper ball joint pg. 157 94017, 1/2" ext upper ball joint pg. 157 94011, lower ball joint pg. 157	71-85	RWD	N/A	N/A			47700(*) 97130 94378(22)	47700(*) 97130	84 138,138 136
Lucerne	06-11	FWD	75600(1) 75800(1)	OEMA 75600(1) 75800(1)	116 116,116 116		N/A	81280 82120/85130	117 122/173
Park Avenue	97-05	FWD	75600(1) 75800(1)	OEMA 75600(1) 75800(1)	116 116,116 116		OEMA	81280 82120/85130	117 122/173
Park Avenue	90-96	FWD	81280 82120/85130	OEMA	117 122/173		OEMA	81280 82120/85130	117 122/173
Rainier	04-07	RWD/4WD	N/A	N/A			OEMA/83785	OEMA/83785	172,172
Reatta	89-91	FWD	75600(1) 75800(1)	OEMA 75600(1) 75800(1)	116 116,116 116		OEMA	81280 82120/85130	117 122/173
Regal Sportback/TourX	18-20	AWD	OEMA 82090/45938	OEMA 82090/45938	120/167		N/A	81250	117
Regal Sportback/TourX	18-20	FWD	OEMA	OEMA			N/A	81250	117

Applications

Alignment Parts

Heavy Duty

OE Replacement

Racing/Builders

Tools

Brake and CV

Gear/Index

CAR/MINI-VAN/SUV/TRUCK APPLICATIONS

BUICK-cont.			REAR			Thrust Plate	FRONT		
Model/Body Style	Year	Drive Type	CAMBER/TOOL	TOE/TOOL	Page		CASTER/TOOL	CAMBER/TOOL	Page
Regal	11-17	AWD	OEMA 82090/45938	OEMA 82090/45938	120/167		N/A	OEMA 82130	122
Regal w/ HiPer Strut	11-17	FWD	OEMA 82090/45938	OEMA 82090/45938	120/167		N/A	OEMA 82130	122
Regal w/o HiPer Strut	11-17	FWD	OEMA 82080	OEMA 82085	120,120		N/A	81250	117
Regal	97-04	FWD	81260	OEMA/83850	117/173		N/A	81260	117
Regal	88-96	FWD	81280 82120/85130	OEMA/83850	117/173 122/173		N/A	N/A/85130	173
Regal 94390, Pro Springs pg. 137 94006, upper ball joint pg. 157 94011, lower ball joint pg. 157	78-87	RWD	N/A	N/A			47700(*) 97140 95336(22)	47700(*) 97140	84,84 138,138 136
Regal 94006, upper ball joint pg. 157 94017, 1/2" ext upper ball joint pg. 157 94011, lower ball joint pg. 157	73-77	RWD	N/A	N/A			47700(*) 97130 94378	47700(*) 97130	84,84 138,138 136
Rendezvous	02-07	AWD	OEMA	OEMA			N/A	81260	117
Rendezvous	02-07	FWD	75600(1) 75800(1)	75600(1) 75800(1)	116,116 116/116		N/A	81260	117
Riviera	95-99	FWD	75600(1) 75800(1)	OEMA 75600(1) 75800(1)	116 116,116 116		OEMA	81280 82120/85130	117 122/173
Riviera	86-93	FWD	75600(1) 75800(1)	OEMA/83775 75600(1) 75800(1)	116/172 116,116 116		OEMA	OEMA 81280 82120/85130	117 122/173
Riviera	79-85	FWD	75600(1) 75800(1)	OEMA/83775 75600(1) 75800(1)	116/172 116,116 116		OEMA	OEMA	
Roadmaster Inc. Estate	91-96	RWD	N/A	N/A			47700(*) 97130 94378(22)	47700(*) 97130	84,84 138,138 136
Skyhawk	82-89	FWD	75400(1)	75400(1)	116,116		N/A	81280 82120/85130	117 122/173
Skylark	96-98	FWD	75400(1)	75400(1)	116,116		N/A	81260	117
Skylark	86-95	FWD	75400(1)	75400(1)	116,116		N/A	81280 82120/85130	117 122/173
Skylark	80-85	FWD	75400(1)	75400(1)	116,116		N/A	82110/85130	121/173
Skylark'X' Body 94006, upper ball joint pg. 157 94017, 1/2" ext upper ball joint pg. 157 94011, lower ball joint pg. 157	75-79	RWD	N/A	N/A			47700(*) 97130 94378(22)	47700(*) 97130	84,84 138,138 136
Skylark 94391, Pro Springs (64-67) pg. 137 94392, Pro Springs (68-72) pg. 137 94001, upper ball joint pg. 157	64-72	RWD	N/A	N/A			47700(*) 97110 94344(22)	47700(*) 97110	84,84 138,138 136
Somerset	85-89	FWD	75400(1)	75400(1)	116,116		N/A	81280 82120/85130	117 122/173
Special 94391, Pro Springs (64-67) pg. 137 94392, Pro Springs (68-72) pg. 137 94001, upper ball joint pg. 157	64-72	RWD	N/A	N/A			47700(*) 97110 94344(22)	47700(*) 97110	84,84 138,138 136
Terraza	05-07	AWD	OEMA	OEMA			N/A	81260	117
Terraza	05-07	FWD	75600(1) 75800(1)	75600(1) 75800(1)	116,116 116,116		N/A	81260	117
Verano	12-17	FWD	71030(*)	71030(*)	103,103		N/A	81250	117

CAR/MINI-VAN/SUV/TRUCK APPLICATIONS

CADILLAC

Model/Body Style	Year	Drive Type	REAR			Thrust Plate	FRONT		
			CAMBER/TOOL	TOE/TOOL	Page		CASTER/TOOL	CAMBER/TOOL	Page
Allante	93-93	FWD	OEMA	OEMA			OEMA/ 85130	81280 82120/ 85130	173 /117 121/ 173
Allante	87-92	FWD	N/A	OEMA			OEMA/ 85130	81280 82120/ 85130	173 /117 121/ 173
ATS	13-19	RWD/AWD	OEMA	OEMA			N/A	81280	117
Brougham	85-92	RWD	N/A	N/A			47700(*)	47700(*)	84,84
Catera	97-01	RWD	N/A	OEMA			N/A	81250	117
Cimarron	82-88	FWD	75400 (1)	75400 (1)	116,116		N/A	81280 82120/ 85130	117 121/ 173
CTS Inc. CTS-V	16-19	RWD/AWD	OEMA	OEMA			N/A	81280	117
CTS Coupe/Wagon/ CTS-V Sedan	14-15	RWD/AWD	OEMA	OEMA			OEMA/ 83785	OEMA/ 83785	172,172
CTS Sedan (except CTS-V)	14-15	RWD/AWD	OEMA	OEMA			N/A	81280	117
CTS Inc. CTS-V	08-13	RWD/AWD	OEMA	OEMA			OEMA/ 83785	OEMA/ 83785	172,172
CTS Inc. CTS-V	03-07	RWD/AWD	OEMA	OEMA			OEMA/ 83775, 83785, 83850	OEMA/ 83850	172,173 172,173
CT6	16-20	RWD/AWD	N/A	OEMA			N/A	N/A	
DeVille	00-05	FWD	75600 (1) 75800 (1)	OEMA 75600 (1) 75800 (1)	116 116,116 116		OEMA	81280 82120/ 85130	117 121/ 173
DeVille Inc. Concours	94-99	FWD	OEMA	OEMA			OEMA	81280 82120/ 85130	117 121/ 173
DeVille	85-93	FWD	OEMA 82120/ 85130	OEMA	121/ 173		OEMA/ 85130	OEMA 82120/ 85130	173 121/ 173
DTS	06-11	FWD	75600 (1) 75800 (1)	OEMA 75600 (1) 75800 (1)	116 116,116 116		OEMA	81280 82120/ 85130	117 121/ 173
Eldorado	93-03	FWD	OEMA	OEMA			OEMA/ 85130	81280 82120/ 85130	173 /117 121/173
Eldorado	86-92	FWD	75600 (1) 75800 (1)	OEMA/ 83775 75600 (1) 75800 (1)	116/ 172 116,116 116		OEMA	OEMA 81280 82120/ 85130	117 121/ 173
Eldorado	80-85	FWD	75600 (1) 75800 (1)	OEMA/ 83775 75600 (1) 75800 (1)	116/ 172 116,116 116		OEMA	OEMA	
Escalade ESV/EXT <i>45940 for use on OEM style cams only.</i>	02-20	RWD/4WD	N/A	N/A			OEMA/ 45940 86320, 86325 86375 86470 (thru '06)	OEMA/ 45940 86320, 86325 86350/ 72509 86375 86470 (thru '06)	167/167 128,128 129,129/ 169 130,129 130
Escalade	99-00	RWD/4WD	N/A	N/A			OEMA 83790/ 74910 87400/ 74910	OEMA 83790/ 74910 87400/ 74910	125/ 170 132/ 170
ELR	14-16	FWD	71030(*)	71030(*)	103,103		N/A	OEMA 82130	122
Fleetwood	85-93	FWD	OEMA	OEMA			OEMA/ 85130	OEMA 82120/ 85130	173 121/ 173
Seville STS/SLS	98-04	FWD	75600 (1) 75800 (1)	OEMA 75600 (1) 75800 (1)	116 116,116 116		OEMA	81280 82120/ 85130	117 121/ 173
Seville STS/SLS	93-97	FWD	OEMA	OEMA			N/A	81280 82120/ 85130	117 121/ 173
Seville	86-92	FWD	75600 (1) 75800 (1)	OEMA/ 83775 75600 (1) 75800 (1)	116/ 172 116,116 116		OEMA	OEMA 81280 82120/ 85130	117 121/ 173
Seville	80-85	FWD	75600 (1) 75800 (1)	OEMA/ 83775 75600 (1) 75800 (1)	116/ 172 116,116 116		OEMA	OEMA	
SRX	10-16	FWD/AWD	OEMA	OEMA			N/A	81280	117
SRX	04-09	RWD/AWD	OEMA	OEMA/ 83850	173		OEMA/ 83785, 83775	OEMA/ 83775	172 172,172
STS	05-11	RWD/AWD	OEMA	OEMA			OEMA/ 83785	OEMA/ 83785	172

Applications

Alignment Parts

Heavy Duty

OE Replacement

Racing/Builders

Tools

Brake and CV

Gear/Index

CAR/MINI-VAN/SUV/TRUCK APPLICATIONS

CADILLAC-cont.			REAR			Thrust Plate	FRONT		
Model/Body Style	Year	Drive Type	CAMBER/TOOL	TOE/TOOL	Page		CASTER/TOOL	CAMBER/TOOL	Page
XLR XLR-V	04-09	RWD	OEMA	OEMA		OEMA	OEMA		
XTS w/ HiPer strut	13-19	FWD/AWD	OEMA 82090	OEMA/45938 82090	167 120,120		N/A	OEMA 82130	122
XTS w/o HiPer strut	13-19	FWD/AWD	OEMA 82090	OEMA/45938 82090	167 120,120		N/A	81250	117
XT4	19-20	FWD/AWD	OEMA	OEMA			N/A	81250	117
XT5	17-20	FWD/AWD	OEMA	OEMA			N/A	81250	117
XT5	20-20	FWD/AWD	OEMA	OEMA			N/A	81250	117
CHEVROLET									
1500, 2500, 3500 (1999/2000 'Classic' only)	88-00	RWD/4WD	N/A	N/A		■	OEMA 83790/74910 87400/74910	OEMA 83790/74910 87400/74910 86350(2)/72509	125/170 132/170 129/169
Astro (1999/2000 'Classic' only)	90-05	AWD	N/A	N/A			OEMA 83790/74910 87400/74910	OEMA 83790/74910 87400/74910	125/170 132/170
Astro	85-05	RWD	N/A	N/A		■	47700(*)	47700(*)	84,84
Avalanche1500 45940 for use on OEM style cams only.	02-13	RWD/4WD	N/A	N/A			OEMA/45940 86320, 86325 86375 86470 (thru '06)	OEMA/45940 86320, 86325 86350/72509 86375 86470 (thru '06)	167,167 128,128 129,129/169 130,129 130
Avalanche 2500 45940 for use on OEM style cams only.	02-06	4WD	N/A	N/A		■	OEMA/45940 23960/72509 86320, 86325 86375	OEMA/45940 23960/72509 86320, 86325 86375 86330/72509	167,167 80/169 128,128 129,129 129/169
Aveo	04-11	FWD	75200(15)	75200(15)	116,116		N/A	81250	117
Bel Air' B' Body	71-81	RWD	N/A	N/A			47700(*) 97130 94378(22)	47700(*) 97130	84,84 138,138 136
Bel Air	65-70	RWD	N/A	N/A			47700(*) 94356	47700(*) 94356	84,84 136
Bel Air	58-64	RWD	N/A	N/A			47700(*) 97150	47700(*) 97150	84,84 138,138
Bel Air 94003, upper ball joint pg. 157	55-57	RWD	N/A	N/A			47700(*) 97170	47700(*) 97170	84,84 138,138
Beretta	96-97	FWD	75400(1)	75400(1)	116,116		N/A	81260	117
Beretta	87-95	FWD	75400(1)	75400(1)	116,116		N/A	81280 82120/85130	117 122/173
Biscayne' B' Body	71-75	RWD	N/A	N/A			47700(*) 97130 94378	47700(*) 97130	84,84 138,138 136
Biscayne	65-70	RWD	N/A	N/A			47700(*) 94356	47700(*)	84,84 136
Biscayne	58-64	RWD	N/A	N/A			47700(*) 97150	47700(*) 97150	84,84 138,138
Blazer	19-20	FWD/AWD	OEMA	OEMA		■	N/A	81250	117
Blazer Full Size (1999/2000 'Classic' only)	92-94	RWD/4WD	N/A	N/A		■	OEMA 83790/74910 87400/74910	OEMA 83790/74910 87400/74910 86350(2)/72509	125/170 132/170 129/169
Blazer S-10	82-04	RWD	N/A	N/A		■	47700(*) 97140 95336(22)	47700(*) 97140	84,84 138,138 136
Blazer S-10	82-04	4WD	N/A	N/A		■	OEMA 83710	OEMA 83710	125,125

Applications

CAR/MINI-VAN/SUV/TRUCK APPLICATIONS

CHEVROLET-cont.

REAR

FRONT

Model/Body Style	Year	Drive Type	CAMBER/TOOL	TOE/TOOL	Page	Thrust Plate	CASTER/TOOL	CAMBER/TOOL	Page
Blazer C5	69-91	RWD	N/A	N/A		■	47700(*)	47700(*)	84,84
Blazer C10	73-86	RWD	N/A	N/A			47700(*) 97180	47700(*) 97180	84,84 138,138
Blazer K5	69-91	4WD	N/A	N/A		■	23000(*)/4169	23000(*)/4169	74/163
Bolt EV	17-20	FWD	N/A	N/A			N/A	81260	117
Camaro	16-20	RWD	OEMA	OEMA			N/A	81280	117
Camaro	10-15	RWD	OEMA 87430	OEMA 87430	133,133		N/A	81280	117
Camaro	93-02	RWD	N/A	N/A			OEMA/83775	OEMA/83775	172,172
Camaro 'F'-Body	82-92	RWD	N/A	N/A			OEMA	OEMA 81280	117
Camaro 'F'-Body 94394, Pro Springs pg. 137 94006, upper ball joint pg. 157 94011, lower ball joint pg. 157	70-81	RWD	N/A	N/A			47700(*) 97130 94378(22)	47700(*) 97130	84,84 138,138 136
Camaro 'F'-Body 94393, Pro Springs pg. 137 94001, upper ball joint pg. 157	67-69	RWD	N/A	N/A			47700(*) 97120 94374(22)	47700(*) 97120	84,84 138,138 136
Caprice PPV	11-17	RWD	OEMA 87430	OEMA 87430	133,133		OEMA	81260	117
Caprice 'B' Body 94006, upper ball joint pg. 157 94017, 1/2" ext upper ball joint pg. 157 94011, lower ball joint pg. 157	71-96	RWD	N/A	N/A			47700(*) 97130 94378(22)	47700(*) 97130	84,84 138,138 136
Caprice	65-70	RWD	N/A	N/A			47700(*) 94356	47700(*) 94356	84,84 136,136
Caprice	58-64	RWD	N/A	N/A			47700(*) 97150	47700(*) 97150	84,84 138,138
Captiva Sport	12-15	FWD/AWD	OEMA 87420	OEMA 87420	133,133		N/A	81260	117
Cavalier	95-05	FWD	75400(1)	75400(1)	116,116		N/A	81260	117
Cavalier	82-94	FWD	75400(1)	75400(1)	116,116		N/A	81280	117
Celebrity	82-90	FWD	75600(1) 75800(1)	75600(1) 75800(1)	116,116 116,116		N/A	82110/85130	121/173
Chevelle 94006, upper ball joint pg. 157 94017, 1/2" ext upper ball joint pg. 157 94011, lower ball joint pg. 157	73-77	RWD	N/A	N/A			47700(*) 97130 94378(22)	47700(*) 97130	84,84 138,138 136
Chevelle 94391, Pro Springs (64-67) pg. 137 94392, Pro Springs (68-72) pg. 137 94001, upper ball joint pg. 157	64-72	RWD	N/A	N/A			47700(*) 97110 94344(22)	47700(*) 97110	84,84 138,138 136
Chevette	76-87	RWD	N/A	N/A			OEMA	OEMA	
Citation	80-85	FWD	75400(1)	75400(1)	116,116		N/A	82110/85130	121/173
City Express	15-18	FWD	N/A	N/A			N/A	81260	117
Classic	04-05	FWD	81250	OEMA	117		N/A	81260	117
Cobalt	05-10	FWD	75400(1)	75400(1)	116,116		N/A	81250	117
Colorado 45945 for use on OE cams only	15-20	RWD/4WD	N/A	N/A			OEMA/45945 86321, 86326 86376	OEMA/45945 86321, 86326 86376	167,167 128,128 129,129
Colorado 45940 for use on OE cams only	04-12	RWD/4WD	N/A	N/A		■	OEMA/45940 45938 86320, 86325 86360 86375	OEMA/45940 45938 86320, 86325 86360 86375	167,167 167,167 128,28 129,129 129,129
Corsica	96-96	FWD	75400(1)	75400(1)	116,116		N/A	81260	117
Corsica	87-95	FWD	75400(1)	75400(1)	116,116		N/A	81280	117
Corvette C8	20-20	RWD	OEMA	OEMA			OEMA	OEMA	
Corvette C5/C6/C7	97-19	RWD	OEMA	OEMA			OEMA	OEMA	
Corvette C4 94007, upper ball joint pg. 157	88-96	RWD	OEMA	OEMA			47700(*) 97190	47700(*) 97190	84,84 140,140
CorvetteC2/C3 94003, upper ball joint pg. 157	63-82	RWD	OEMA 83160	OEMA 47170(*)	124,85		47700(*) 97160	47700(*) 97160	84,84 140,140

Applications

Alignment Parts

Heavy Duty

OE Replacement

Racing/Builders

Tools

Brake and CV

Gear/Index

CAR/MINI-VAN/SUV/TRUCK APPLICATIONS

CHEVROLET-cont.			REAR			Thrust Plate	FRONT		
Model/Body Style	Year	Drive Type	CAMBER/TOOL	TOE/TOOL	Page		CASTER/TOOL	CAMBER/TOOL	Page
Cruze	11-19	FWD	71030(*)	71030(*)	103,103	N/A	81250	117	
C10	73-86	RWD	N/A	N/A		47700(*) 97180	47700(*) 97180	84,84 140,140	
C10,C20,C30,C1500 C2500,C3500,Pickup/Suburban <i>Thrust Plate not for C10/15</i>	65-72	RWD	N/A	N/A		47700(*)	47700(*)	84,84	
C4500 Kodiak	03-09	RWD	N/A	N/A		Axle Wedges	N/A	144	
C4500 Kodiak	03-09	4WD	N/A	N/A		Axle Wedges 23230(*)	23230(*) 24230/74600 24230/74600	144,76 76,79/170 79/170	
C5500 Kodiak	03-09	RWD	N/A	N/A		Axle Wedges	N/A	144	
C5500 Kodiak	03-09	4WD	N/A	N/A		Axle Wedges 23230(*)	23230(*) 24230/74600 24230/74600	76 76,79/170 79/170	
El Camino <i>94390, Pro Springs pg. 137</i> <i>94006, upper ball joint pg. 157</i> <i>94011, lower ball joint pg. 157</i>	78-88	RWD	N/A	N/A		47700(*) 97140 95336(22)	47700(*) 97140	84,84 138,138 136	
El Camino <i>94006, upper ball joint pg. 157</i> <i>94017, 1/2" ext upper ball joint pg. 157</i> <i>94011, lower ball joint pg. 157</i>	73-77	RWD	N/A	N/A		47700(*) 97130 94378(22)	47700(*) 97130	84,84 138,138 136	
El Camino <i>94001, upper ball joint pg. 157</i>	64-72	RWD	N/A	N/A		47700(*) 97110 94344(22),	47700(*) 97110	84,84 138,138 136	
El Camino	58-63	RWD	N/A	N/A		47700(*) 97150	47700(*) 97150	84,84 138,138	
Equinox	18-20	FWD/AWD	OEMA	OEMA		N/A	81250	117	
Equinox	05-17	FWD/AWD	OEMA 87420	OEMA 87420	133,133	N/A	81260	117	
Express <i>45940 for use on OEM style cams only.</i>	03-20	RWD/4WD	N/A	N/A		OEMA/45940 86320, 86325 86370, 86375	OEMA/45940 86320, 86325 86370, 86375 86350 (33)/72509	167,167 128,128 129,129 129/169	
Express	96-02	RWD	N/A	N/A		OEMA 83790/74910 87400/74910	OEMA 83790/74910 87400/74910	125/170 132/170	
G10 Van	71-72	RWD	N/A	N/A		47700(*)	47700(*)	84,84	
G10 Van	73-95	RWD	N/A	N/A		47700(*) 97180	47700(*) 97180	84,84 140,140	
G20 Van	71-77	RWD	N/A	N/A		47700(*)	47700(*)	84,84	
G20 Van	78-98	RWD	N/A	N/A		47700(*) 97180	47700(*) 97180	84,84 140,140	
HHR	06-11	FWD	75400(1)	75400(1)	116,116	N/A	81250	117	
Impala Limited	14-16	FWD	81260	OEMA	117	N/A	81260	117	
Impala	14-20	FWD	OEMA	OEMA		N/A	81250	117	
Impala	99-13	FWD	81260	OEMA	117	N/A	81260	117	
Impala 'B' Body <i>94006, upper ball joint pg. 157</i> <i>94017, 1/2" ext upper ball joint pg. 157</i> <i>94011, lower ball joint pg. 157</i>	71-96	RWD	N/A	N/A		47700(*) 97130 94378(22)	47700(*) 97130	84,84 138,138 136	
Impala	65-70	RWD	N/A	N/A		47700(*) 94356	47700(*) 94356	84,84 136,136	
Impala	58-64	RWD	N/A	N/A		47700(*) 97150	47700(*) 97150	84,84 138,138	
K10,K15,K20,K25 Pickup/Suburban	70-87	4WD	N/A	N/A		23000(*)/4169	23000(*)/4169	74/163	
K30 K35	58-87	4WD	N/A	N/A		Axle Wedges	23000(*)/4169	144,74/163	

Applications

CAR/MINI-VAN/SUV/TRUCK APPLICATIONS

CHEVROLET-cont.

REAR

FRONT

Model/Body Style	Year	Drive Type	CAMBER/TOOL	TOE/TOOL	Page	Thrust Plate	CASTER/TOOL	CAMBER/TOOL	Page
K30,V30 Dana 60	88-93	4WD	N/A	N/A		■	Axle Wedges 88940	88940	144,134 134
Lumina Sedan	95-01	FWD	81260	OEMA/83850	117/173		N/A	N/A/85130	173
Lumina Sedan	90-94	FWD	81280 82120/85130	OEMA/83850	117/173 121/173		N/A	N/A/85130	173
Lumina APV Van	90-96	FWD	75600(1) 75800(1)	75600(1) 75800(1)	116/116 116/116		N/A	82110/85130	121/173
Luv Pickup	80-82	RWD/4WD	N/A	N/A		■	47700(*)	47700(*)	84,84
Malibu Inc. Limited	13-20	FWD	OEMA	OEMA			N/A	81250	117
Malibu Classic	08-08	FWD	OEMA 75400(17)	OEMA 75400(17)	116/116		N/A	81250	117
Malibu Classic	04-05	FWD	81250	OEMA	117		N/A	81260	117
Malibu	04-12	FWD	OEMA 75400(17) 82100	OEMA 75400(17) 82100	116,116 121,121		N/A	81250	117
Malibu	97-03	FWD	81250	OEMA	117		N/A	81260	117
Malibu 94390, Pro Springs pg. 137 94006, upper ball joint pg. 157 94011, lower ball joint pg. 157	78-83	RWD	N/A	N/A			47700(*) 97140 95336(22)	47700(*) 97140	84,84 138,138 136
Malibu 94006, upper ball joint pg. 157 94017, 1/2" ext upper ball joint pg. 157 94011, lower ball joint pg. 157	73-77	RWD	N/A	N/A			47700(*) 97130 94378(22)	47700(*) 97130	84,84 138,138 136
Malibu 94391, Pro Springs (64-67) pg. 137 94392, Pro Springs (68-72) pg. 137 94001, upper ball joint pg. 157	64-72	RWD	N/A	N/A			47700(*) 97110 94344(22)	47700(*) 97110	84,84 138,138 136
Metro	98-01	FWD	N/A	OEMA			N/A	81250	117
Monte Carlo	00-07	FWD	81260	OEMA	117		N/A	81260	117
Monte Carlo	95-99	FWD	81280 82120/85130	OEMA/83850	117/173 122/173		N/A	N/A/85130	173
Monte Carlo 94390, Pro Springs pg. 137 94006, upper ball joint pg. 157 94011, lower ball joint pg. 157	78-88	RWD	N/A	N/A			47700(*) 97140 95336(22)	47700(*) 97140	84,84 138,138 136
Monte Carlo 94390, Pro Springs pg. 137 94006, upper ball joint pg. 157 94011, lower ball joint pg. 157	73-77	RWD	N/A	N/A			47700(*) 97140 95336(22)	47700(*) 97140	84,84 138,138 136
Monte Carlo 94392, Pro Springs pg. 137 94001, upper ball joint pg. 157	70-72	RWD	N/A	N/A			47700(*) 97110 94344(22)	47700(*) 97110	84,84 138,138 136
Nova	85-88	FWD	81250	OEMA	117		N/A	OEMA 81250	117
Nova 'X' Body 94391, Pro Springs (64-67) pg. 137 94392, Pro Springs (68-72) pg. 137 94001, upper ball joint pg. 157	75-79	RWD	N/A	N/A			47700(*) 97110 94344(22)	47700(*) 97110	84,84 138,138 136
Nova 'X' Body 94393, Pro Springs pg. 137 94001, upper ball joint pg. 157	68-74	RWD	N/A	N/A			47700(*) 97120 94374(22)	47700(*) 97120	84,84 138,138 136
Optra	03-07	FWD	81250	OEMA	117		N/A	81250	117
Prizm	98-02	FWD	75600(1) 75800(1) 81250	OEMA 75600(1) 75800(1)	116 116,116 117,116		N/A	OEMA 81260	117
R10	87-87	RWD	N/A	N/A			47700(*) 97180	47700(*) 97180	84,84 140,140
R10,R20,R30,R1500 R2500,R3500 Pickup/Suburban	88-91	RWD	N/A	N/A		■	47700(*)	47700(*)	84,84

Applications

Alignment Parts

Heavy Duty

OE Replacement

Racing/Builders

Tools

Brake and CV

Gear/Index

CAR/MINI-VAN/SUV/TRUCK APPLICATIONS

CHEVROLET-cont.			REAR			Thrust Plate	FRONT		
Model/Body Style	Year	Drive Type	CAMBER/TOOL	TOE/TOOL	Page		CASTER/TOOL	CAMBER/TOOL	Page
Silverado 1500	19-20	RWD/4WD	N/A	N/A		■ OEMA	OEMA		
Silverado 1500 <i>45940 for use on OEM style cams only.</i>	99-18	RWD/4WD	N/A	N/A		■ OEMA/ 45940 86320, 86325 86375 86470 (thru '06)	OEMA/ 45940 86320, 86325 86375 86350/ 72509 86470 (thru '06)	167,167 128,128 129,129 130,129/ 169 130	
Silverado 1500 HD Crew Cab <i>45940 for use on OEM style cams only.</i>	01-06	RWD/4WD	N/A	N/A		■ OEMA/ 45940 23960/ 72509 86320, 86325 86375	OEMA/ 45940 23960/ 72509 86320, 86325 86375 86330/ 72509	167,167 90,90/ 169 128,128 129,129 129, 169	
Silverado 2500 <i>45945 for use on OEM style cams only.</i>	11-20	RWD/4WD	N/A	N/A		■ OEMA/ 45945 86321, 86326 86376	OEMA/ 45945 86321, 86326 86376	167,167 128,128 129,129	
Silverado 2500 <i>45940 for use on OEM style cams only.</i>	99-10	RWD/4WD	N/A	N/A		■ OEMA/ 45940 23960/ 72509 86320, 86325 86375	OEMA/ 45940 23960/ 72509 86320, 86325 86375 86330/ 72509	167,167 90,90/ 169 128,128 129,129 129, 169	
Silverado 2500HD RWD Cab/Chassis	91-02	RWD	N/A	N/A		■ Axle Wedges	N/A	144	
Silverado 3500 <i>45945 for use on OEM style cams only.</i>	11-20	RWD/4WD	N/A	N/A		■ OEMA/ 45945 86321, 86326 86376	OEMA/ 45945 86321, 86326 86376	167,167 128,128 129,129	
Silverado 3500 <i>45940 for use on OEM style cams only.</i>	99-10	RWD/4WD	N/A	N/A		■ OEMA/ 45940 23960/ 72509 86320, 86325 86375	OEMA/ 45940 23960/ 72509 86320, 86325 86375 86330/ 72509	167,167 90,90/ 169 128,128 129,129 129, 169	
Silverado 3500HD RWD Cab/Chassis	91-02	RWD	N/A	N/A		■ Axle Wedges	N/A	144	
Sonic	12-20	FWD	71050(*)	71050(*)	103,103	■ N/A	81260	117	
Spark	13-20	FWD	N/A	N/A		■ N/A	81250	117	
Spectrum	85-88	FWD	75200(1)	75200(1)	116,116	■ N/A	81250	117	
Sprint Metro	87-88	FWD	N/A	N/A		■ N/A	OEMA 81250	117	
Sprint	85-86	FWD	N/A	N/A		■ N/A	81250	117	
Suburban 1500 <i>45940 for use on OEM style cams only.</i>	00-20	RWD/4WD	N/A	N/A		■ OEMA/ 45940 86320, 86325 86375 86470 (thru '06)	OEMA/ 45940 86320, 86325 86375 86350/ 72509 86470 (thru '06)	167,167 128,128 129,129 130,129/ 169 130	
Suburban 2500 <i>45940 for use on OEM style cams only.</i>	00-14	RWD/4WD	N/A	N/A		■ OEMA/ 45940 23960/ 72509 86320, 86325 86375	OEMA/ 45940 23960/ 72509 86320, 86325 86375 86330/ 72509	167,167 90,90/ 169 128,128 129,129 129, 169	
Suburban	92-99	RWD/4WD	N/A	N/A		■ OEMA 83790/ 74910 87400/ 74910	OEMA 83790/ 74910 87400/ 74910 86350(2)/ 72509	125/ 170 132/ 170 129, 169	
Suburban C10/R10	73-97	RWD	N/A	N/A		■ 47700(*) 97180	47700(*) 97180	84,84 140,140	
Suburban	69-91	4WD	N/A	N/A		■ 23000(*)/ 4169	23000(*)/ 4169	74/ 163	
Suburban	65-72	RWD	N/A	N/A		■ 47700(*)	47700(*)	84,84	
SS	14-17	RWD	OEMA 87430	OEMA 87430	113,113	■ N/A	81260	117	
SSR	04-06	RWD	N/A	N/A		■ OEMA/ 83785	OEMA/ 83785	172,172	

CAR/MINI-VAN/SUV/TRUCK APPLICATIONS

CHEVROLET-cont.

Model/Body Style	Year	Drive Type	REAR			Thrust Plate	FRONT		
			CAMBER/TOOL	TOE/TOOL	Page		CASTER/TOOL	CAMBER/TOOL	Page
S10 <i>94006, upper ball joint pg 157</i>	82-04	RWD	N/A	N/A		■	47700(*) 97140 95336(22)	47700(*) 97140	84,84 138,138 136
S10	82-04	4WD	N/A	N/A		■	OEMA 83710	OEMA 83710	125,125
Tahoe <i>45940 for use on OEM style cams only.</i>	07-20	RWD/4WD	N/A	N/A			OEMA/45940 86320, 86325 86375 86470 (thru '06)	OEMA/45940 86320, 86325 86375 86350/72509 86470 (thru '06)	167,167 128,128 129,129 130,129/169 130
Tahoe	95-99	RWD/4WD	N/A	N/A		■	OEMA 83790/74910 87400/74910	OEMA 83790/74910 87400/74910 86350(2)/72509	125/170 132/170 132/169
Tracker	98-04	4WD	N/A	N/A		■	N/A	81250	117
Trailblazer	02-09	RWD/4WD	N/A	N/A			OEMA/83785	OEMA/83785	172,172
Traverse	18-20	FWD/AWD	OEMA	OEMA			N/A	81250	117
Traverse	09-17	FWD/AWD	OEMA 82105, 82106	OEMA	121,121		N/A	81280	117
Stock Replacement Part			15647		158				
Trax	15-20	AWD	N/A	N/A			N/A	81260	117
Trax	15-20	FWD	71050(*)	71050(*)	103,103		N/A	81260	117
Tri-5 Body <i>94003, upper ball joint pg. 157</i>	55-57	RWD	N/A	N/A			47700(*) 97170	47700(*) 97170	84,84 140,140
Uplander	05-08	AWD	OEMA	OEMA			N/A	81260	117
Uplander	05-08	FWD	75600(1) 75800(1)	75600(1) 75800(1)	116,116 116,116		N/A	81260	117
Venture	02-05	AWD	OEMA	OEMA			N/A	81260	117
Venture	97-05	FWD	75600(1) 75800(1)	75600(1) 75800(1)	116,116 116,116		N/A	81260	117
Volt	11-19	FWD	71030(*)	71030(*)	103,103		N/A	81250	117
V30 Dana 60	87-88	4WD	N/A	N/A		■	Axle Wedges 88940	88940	144,134 134
V3500 Dana 60	89-91	4WD	N/A	N/A			Axle Wedges 88940	88940	144,134 134

CHRYSLER

All Passenger Car Models	60-73	RWD	N/A	N/A			OEMA 83160	OEMA 83160	124,124
200	15-17	FWD/AWD	OEMA	OEMA			N/A	N/A	
200	11-14	FWD	67018 75600(1)	75600(1)	87,116 116		N/A	81260	117
300	11-20	RWD	66050/ 40920, 66025	OEMA 66055/ 40920, 66025	86 165,168/87 165,168		66038/74920 66045	66038/74920 66045	86/170 86
300	09-10	RWD	66050/ 40920, 66025	OEMA 66055/ 40920, 66025	86 165,168/87 165,168		66037/74920 66045	66037/74920 66045	86/170 86
300	05-08	RWD	66050/ 40920, 66025	OEMA 66055/ 40920, 66025	86 165,168/87 165,168		66037/74920 66040	66037/74920 66040	86/170 86
300	05-20	AWD	66050/ 40920, 66025	OEMA 66055/ 40920, 66025	86 165,168/87 165,168		66047	66047	86,86
300M <i>55700, toe tool pg. 167</i>	99-04	FWD	67080	OEMA	88		N/A	81280 82120/85130	117 122/173
Stock Replacement Part							23600		77
Aspen	07-09	RWD/AWD	N/A	N/A			OEMA	OEMA	
Cirrus	95-00	FWD	OEMA	OEMA			N/A	67180/40920	89/165
Concorde <i>55700, toe tool pg. 167</i>	98-04	FWD	67080	OEMA	88		N/A	81280 82120/85130	117 122/173
Stock Replacement Part							23600		77

Applications

Alignment Parts

Heavy Duty

OE Replacement

Racing/Builders

Tools

Brake and CV

Gear/Index

CAR/MINI-VAN/SUV/TRUCK APPLICATIONS

CHRYSLER-cont.			REAR			Thrust Plate	FRONT		
Model/Body Style	Year	Drive Type	CAMBER/TOOL	TOE/TOOL	Page		CASTER/TOOL	CAMBER/TOOL	Page
Concorde <i>55600, toe tool pg. 167</i>	93-97	FWD	67020	OEMA	WB	N/A	81280 82120/ 85130	117 122/ 173	
Crossfire Inc. SRT6	04-08	RWD	28840/ 75990, 72509	OEMA	83 171,169	28815	28815	83,83	
E Class	83-86	FWD	75200 (1)	75200 (1)	116,116	N/A	OEMA 83170/ 85130	125/ 173	
Executive Sedan	83-86	FWD	75200 (1)	75200 (1)	116,116	N/A	OEMA 83170/ 85130	125/ 173	
Fifth Avenue	90-93	FWD	75200 (1)	75200 (1)	116,116	N/A	OEMA 83170/ 85130	125/ 173	
Imperial	90-93	FWD	75200 (1)	75200 (1)	116,116	N/A	OEMA 83170/ 85130	125/ 173	
Imperial	81-83	RWD	N/A	N/A		OEMA/ 8286	OEMA/ 8286	163,163	
Laser	84-86	FWD	75200 (1)	75200 (1)	116,116	N/A	OEMA 83170/ 85130	125/ 173	
LeBaron	82-95	FWD	75200 (1)	75200 (1)	116,116	N/A	OEMA 83170/ 85130	125/ 173	
LHS <i>55700, toe tool pg. 167</i>	98-01	FWD	67080	OEMA	88	N/A	81280 82120/ 85130	117 122/ 173	
Stock Replacement Part							23600	77	
LHS <i>55600, toe tool pg. 167</i>	94-97	FWD	67020	OEMA	WB	N/A	81280 82120/ 85130	117 122/ 173	
New Yorker <i>55600, toe tool pg. 167</i>	94-97	FWD	67020	OEMA	WB	N/A	81280 82120/ 85130	117 122/ 173	
New Yorker 5th Ave.	83-89	RWD	N/A	N/A		OEMA	OEMA		
New Yorker	83-93	FWD	75200 (1)	75200 (1)	116,116	N/A	OEMA 83170/ 85130	125/ 173	
Pacifica	17-20	FWD	OEMA	OEMA		N/A	81260	117	
Pacifica	04-08	AWD/FWD	66050/ 40920, 66025	OEMA 66055/ 66025, 40920	86 165,168/87 165,168	N/A	81260	117	
PT Cruiser	01-10	FWD	71740(*)	71740(*)	104,104	N/A	81260	117	
Sebring	07-10	FWD	67015	OEMA	87	N/A	81260	117	
Sebring Sedan & Conv.	04-06	FWD	67025	OEMA	87	N/A	67180/ 40920	89/ 165	
Sebring Sedan & Conv.	01-03	FWD	OEMA	OEMA		N/A	67180/ 40920	89/ 165	
Sebring 2Dr. Coupe <i>73400 must be used with 73415</i>	01-06	FWD	73400+73415 (7) 73600, 73620(8)	OEMA	115,115 115,115	N/A	81280 82120/ 85130	117 122/ 173	
Sebring Conv.	96-00	FWD	OEMA	OEMA		N/A	67180/ 40920	89/ 165	
Sebring 2Dr. Coupe <i>73400 must be used with 73415</i>	95-00	FWD	73400+73415 (7) 73600, 73620(8)	OEMA	115,115 115,115	N/A	67170/40920 67370 (8)/40920	89/ 165 92/ 165	
Town & Country	01-16	AWD	N/A	N/A		N/A	81260 83170/ 85130	117 125/ 173	
Town & Country	01-16	FWD	71700 (*) (1)	71700 (*) (1)	104,104	N/A	OEMA 81260 83170/ 85130	117 125/ 173	
Town & Country	96-00	AWD	N/A	N/A		N/A	OEMA 83170/ 85130	125/ 173	
Town & Country	96-00	FWD	71700(*)	71700(*)	104,104	N/A	OEMA 83170/ 85130	125/ 173	
Town & Country	90-95	AWD	N/A	N/A		N/A	OEMA 83170/ 85130	125/ 173	
Town & Country	90-95	FWD	75400 (1)	75400 (1)	116,116	N/A	OEMA 83170/ 85130	125/ 173	
Town & Country	82-88	FWD	75200 (1)	75200 (1)	116,116	N/A	OEMA 83170/ 85130	125/ 173	

CAR/MINI-VAN/SUV/TRUCK APPLICATIONS

CHRYSLER-cont.

REAR

FRONT

Model/Body Style	Year	Drive Type	CAMBER/TOOL	TOE/TOOL	Page	Thrust Plate	CASTER/TOOL	CAMBER/TOOL	Page
Voyager	00-03	AWD	N/A	N/A			N/A	81260 83170/ 85130	117 125/ 173
Voyager	00-03	FWD	71700(*)	71700(*)	104,104		N/A	OEMA 81260 83170/ 85130	117 125/ 173

DODGE/RAM

All Passenger B&E (Except 880) <i>94009, upper ball joint pg. 157</i>	62-65	RWD	N/A	N/A			OEMA 97300	OEMA 97300	140,140
All Passenger Car (Except B&E)	60-73	RWD	N/A	N/A			OEMA 83160	OEMA 83160	124,124
400	82-83	FWD	75200(1)	75200(1)	116,116		N/A	OEMA 83170/ 85130	125/ 173
600	83-88	FWD	75200(1)	75200(1)	116,116		N/A	OEMA 83170/ 85130	125/ 173
Aries	81-89	FWD	75200(1)	75200(1)	116,116		N/A	OEMA 83170/ 85130	125/ 173
Avenger	11-14	FWD/AWD	67018	OEMA	87		N/A	81260	117
Avenger	08-10	FWD/AWD	67015	OEMA	87		N/A	81260	117
Avenger <i>73400 must be used with 73415</i>	95-00	FWD	73400+73415(7) 73600, 73620(8)	OEMA	115,115 115,115		N/A	67170/40920 67370(8)/ 40920	89/ 165 92/ 165
B100 B200 B300 Ram Van	70-80	RWD	N/A	N/A		■	OEMA 83160	OEMA 83160	124,124
B150 B250 B350 Ram Van	81-01	RWD	N/A	N/A		■	OEMA/ 8286	OEMA/ 8286	163,163
Caliber	07-12	FWD/AWD	67455	OEMA	94		N/A	81260	117
Caravan	01-07	AWD	N/A	N/A			N/A	OEMA 81260 83170/ 85130	117 125/ 173
Caravan	01-07	FWD	71700(*1)	71700(*1)	104,104		N/A	OEMA 81260 83170/ 85130	117 125/ 173
Caravan	96-00	AWD	N/A	N/A			N/A	OEMA 83170/ 85130	125/ 173
Caravan	96-00	FWD	71700(*)	71700(*)	104,104		N/A	OEMA 83170/ 85130	125/ 173
Caravan	90-95	AWD	N/A	N/A			N/A	OEMA 83170/ 85130	125/ 173
Caravan	84-95	FWD	75400(1)	75400(1)	116,116		N/A	OEMA 83170/ 85130	125/ 173
Challenger	17-20	AWD	66050/ 40920, 66025	OEMA 66055/ 40920, 66025	86 165,168/87 165,168		66047	66047	86,86
Challenger	11-20	RWD	66050/ 40920, 66025	OEMA 66055/ 40920, 66025	86 165,168/87 165,168		66038/ 74920 66045	66038/ 74920 66045	86/ 170 86,86
Challenger	09-10	RWD	66050/ 40920, 66025	OEMA 66055/ 40920, 66025	86 165,168/87 165,168		66037/ 74920 66045	66037/ 74920 66045	86/ 170 86,86
Challenger	08-08	RWD	66050/ 40920, 66025	OEMA 66055/ 40920, 66025	86 165,168/87 165,168		66037/ 74920 66040	66037/ 74920 66040	86/ 170 86,86
Challenger	80-83	RWD	N/A	N/A			OEMA	N/A	
Challenger <i>94009, upper ball joint pg. 157</i>	70-74	RWD	N/A	N/A			OEMA 97300	OEMA 97300	140,140
Charger	11-20	RWD	66050/ 40920, 66025	OEMA 66055/ 40920, 66025	86 165,168/87 165,168		66038/ 74920 66045	66038/ 74920 66045	86/ 170 86,86
Charger	09-10	RWD	66050/ 40920, 66025	OEMA 66055/ 40920, 66025	86 165,168/87 165,168		66037/ 74920 66045	66037/ 74920 66045	86/ 170 86,86

Applications

Alignment Parts

Heavy Duty

OE Replacement

Racing/Builders

Tools

Brake and CV

Gear/Index

CAR/MINI-VAN/SUV/TRUCK APPLICATIONS

DODGE/RAM-cont.			REAR			Thrust Plate	FRONT		
Model/Body Style	Year	Drive Type	CAMBER/TOOL	TOE/TOOL	Page		CASTER/TOOL	CAMBER/TOOL	Page
Charger	06-08	RWD	66050/ 40920, 66025	OEMA 66055/ 40920, 66025	86 165,168/87 165,168	66037/74920 66040	66037/74920 66040	86/170 86,86	
Charger	06-20	AWD	66050/ 40920, 66025	OEMA 66055/ 40920, 66025	86 165,168/87 165,168	66047	66047	86,86	
Charger	82-87	FWD	75200(1)	75200(1)		N/A	OEMA 83170/85130	125/173	
Charger <i>94009, upper ball joint pg. 157</i>	66-72	RWD	N/A	N/A		OEMA 97300	OEMA 97300	140,140	
Colt	93-94	FWD	OEMA	OEMA		N/A	81250	117	
Colt Vista	92-94	FWD/AWD	N/A	OEMA		N/A	OEMA		
Colt Vista	84-91	FWD/AWD	N/A	OEMA		OEMA	81250	117	
Colt Vista	84-94	4WD	N/A	OEMA		N/A	81250	117	
Colt	80-87	RWD	N/A	N/A		OEMA	81250	117	
Colt	80-93	FWD	N/A	N/A		N/A	81250	117	
Conquest	84-86	RWD	N/A	OEMA		OEMA	N/A		
Coronet Inc. Super Bee <i>94009, upper ball joint pg. 157</i>	65-72	RWD	N/A	N/A		OEMA 97300	OEMA 97300	140,140	
D100, D150, D200 D250 Truck	72-87	RWD	N/A	N/A		■ OEMA 83160	OEMA 83160	124,124	
D150, D250 D350 Truck	88-93	RWD	N/A	N/A		■ OEMA	OEMA		
D300, D350, D400 D450 Truck	72-87	RWD	N/A	N/A		■ OEMA 83160	OEMA 83160	124,124	
Dakota	05-11	RWD/4WD	N/A	N/A		OEMA 82400	OEMA 82400	124,124	
Dakota	87-04	RWD/4WD	N/A	N/A		■ OEMA/ 6140, 8286	OEMA/ 6140, 8286	163,163	
Dart	13-16	FWD	N/A	OEMA		N/A	N/A		
Dart <i>94009, upper ball joint pg. 157</i>	73-76	RWD	N/A	N/A		OEMA 97300	OEMA 97300	140,140	
Daytona	84-94	FWD	75200(1)	75200(1)	116,116	N/A	OEMA 83170/85130	125/173	
Durango	11-20	RWD/AWD	OEMA	OEMA		OEMA	OEMA 82360	122	
Durango	04-10	RWD/AWD	N/A	N/A		OEMA	OEMA		
Durango	98-03	RWD/AWD	N/A	N/A		■ OEMA/ 6140, 8286	OEMA/ 6140, 8286	163,163	
Dynasty	88-93	FWD	75200(1)	75200(1)	116,116	N/A	OEMA 83170/85130	125/173	
Grand Caravan	01-20	AWD	N/A	N/A		N/A	81260 83170/85130	117 125/173	
Grand Caravan	01-20	FWD	71700(*) (1)	71700(*) (1)	104,104	N/A	OEMA 81260 83170/85130	117 125/173	
Grand Caravan	96-00	AWD	N/A	N/A		N/A	OEMA 83170/85130	125/173	
Grand Caravan	96-00	FWD	71700(*)	71700(*)	104,104	N/A	OEMA 83170/85130	125/173	
Grand Caravan	90-95	AWD	N/A	N/A		N/A	OEMA 83170/85130	125/173	
Grand Caravan	84-95	FWD	75400(1)	75400(1)	116,116	N/A	OEMA 83170/85130	125/173	

CAR/MINI-VAN/SUV/TRUCK APPLICATIONS

DODGE/RAM-cont.

REAR

FRONT

Model/Body Style	Year	Drive Type	CAMBER/TOOL	TOE/TOOL	Page	Thrust Plate	CASTER/TOOL	CAMBER/TOOL	Page
Intrepid 55700, toe tool pg. 167 Stock Replacement Part	98-04	FWD	67080	OEMA	88		N/A	81280 82120/ 85130	117 122/ 173
							23600		77
Intrepid 55600, toe tool pg. 167	93-97	FWD	67020	OEMA	WB		N/A	81280	117
Journey	11-20	AWD	67018	OEMA			N/A	81260	117
Journey	11-20	FWD	67018	OEMA			N/A	81260	117
Journey	09-10	FWD/AWD	67015	OEMA			N/A	81260	117
Lancer	85-89	FWD	75200(1)	75200(1)	116,116		N/A	OEMA 83170/ 85130	125/ 173
Magnum	05-08	AWD	66050/ 40920, 66025	OEMA 66055/ 40920, 66025	86 165,168/87 165,168		66047	66047	86,86
Magnum	05-08	RWD	66050/ 40920, 66025	OEMA 66055/ 40920, 66025	86 165,168/87 165,168		66037/ 74920 66040	66037/ 74920 66040	86/ 170 86,86
Monaco	90-92	FWD	75200(1)	75200(1)	116,116		N/A	81280 82120/ 85130	117 122/ 173
Neon Inc. SRT4	94-06	FWD	67210 81250	OEMA 67210	90 117,90		N/A	81260	117
Nitro	07-12	RWD/AWD	N/A	N/A			OEMA 82365	OEMA 82365	122,122
Omni Inc. O24	78-90	FWD	75200(1)	75200(1)	116,116		N/A	OEMA 83170/ 85130	125/ 173
Promaster	14-19	FWD	N/A	N/A			N/A	N/A	
Promaster City	15-19	FWD	N/A	N/A			N/A	81250	117
Raider	87-89	RWD/AWD	N/A	N/A		■	OEMA	OEMA	
Ram C/V - Tradesman	12-15	AWD	N/A	N/A			N/A	OEMA 81260 83170/ 85130	117 125/ 173
Ram C/V - Tradesman	12-15	FWD	71700(*) (1)	71700(*) (1)	104,104		N/A	OEMA 81260 83170/ 85130	117 125/ 173
Ram 1500 (DT)	19-20	RWD/4WD	N/A	N/A			OEMA 82420	OEMA 82420	124,124
Ram 1500 Mega Cab	06-08	RWD	N/A	N/A			OEMA	OEMA	
Ram 1500 Mega Cab	06-08	4WD	N/A	N/A			23800(*)/ 72509, 23780 82385(16)	23800(*)/ 72509, 23780	78,78 169,163 123
Ram 1500 Exc. Mega Cab	06-18	RWD/4WD	N/A	N/A			OEMA 23940/ 72509 82420/ 37995	OEMA 23940/ 72509 82420/ 37995	78/ 163 124/ 164
Ram 1500	02-05	RWD	N/A	N/A		■	OEMA 23765	OEMA 23765	77,77
Ram 1500	02-05	4WD	N/A	N/A		■	OEMA 23755	OEMA 23755	77,77
Ram 1500	00-01	4WD	N/A	N/A		■	23510(*)/ 72509, 23580 82385(16)	23510(*)/ 72509, 23580	78,78 169,163 123
Ram 1500 82380 with 36mm OE cams. 82395 with 46mm OE cams.	94-99	4WD	N/A	N/A		■	23510(*)/ 72509, 23580 82380(16) 82395(16)	23510(*)/ 72509, 23580	78,78 169,163 123 124
Ram 1500	94-01	RWD	N/A	N/A		■	OEMA/ 8286	OEMA/ 8286	163,163
Ram 1500 Classic	19-19	RWD/4WD	N/A	N/A			OEMA 23940/ 72509, 37995 82420	OEMA 23940/ 72509, 37995 82420	78,78 169,163 124
Ram 2500 Exc. Mega Cab Stock Replacement Part	14-20	RWD	N/A	N/A			OEMA	OEMA	77,77

Applications

Alignment Parts

Heavy Duty

OE Replacement

Racing/Builders

Tools

Brake and CV

Gear/Index

CAR/MINI-VAN/SUV/TRUCK APPLICATIONS

DODGE/RAM-cont.			REAR			Thrust Plate	FRONT		Page
Model/Body Style	Year	Drive Type	CAMBER/TOOL	TOE/TOOL	Page		CASTER/TOOL	CAMBER/TOOL	
Ram 2500	14-20	4WD	N/A	N/A			23800(*)/ 23780, 72509 82387(16)	23800(*) 23780, 72509	78,78 163,169 123
Stock Replacement Part							23610, 23615		77
Ram 2500	10-13	4WD	N/A	N/A		■	23800(*)/ 23780, 72509 82386(16)	23800(*)/ 23780, 72509	78,78 163,169 123
Ram 2500	03-09	4WD	N/A	N/A		■	23800(*)/ 23780, 72509 82385(16)	23800(*)/ 23780, 72509	78,78 163,169 123
Ram 2500	00-02	4WD	N/A	N/A		■	23710(*)/ 23780, 72509 82385(16)	23710(*)/ 23780, 72509	78,78 163,169 123
Ram 2500	00-13	RWD	N/A	N/A		■	OEMA	OEMA	
Ram 2500	94-99	RWD	N/A	N/A		■	OEMA/8286	OEMA/8286	163,163
Ram 2500 w/HD Dana 60 Fr Axle	94-99	4WD	N/A	N/A		■	23130(*)/ 88830, 77880 24130/74500 82395(16)	23130(*)/ 88830, 77880 24130/74500	75,75 175,171 79/170 124
Ram 2500 w/LD Dana 44 Fr Axle.	94-99	4WD	N/A	N/A		■	23510(*)/ 23580, 72509	23510(*)/ 23580, 72509	78,78 163,169
Ram 3500	14-19	4WD	N/A	N/A		■	23800(*)/ 23780, 72509 82387(16)	23800(*)/ 23780, 72509	78,78 163,169 123
Stock Replacement Part							23610, 23615		77
Ram 3500 w/mono beam	14-20	RWD	N/A	N/A		■	23800(*)/ 23780, 72509 82387(16)	23800(*)/ 23780, 72509	78,78 163,169 123
Stock Replacement Part							23610, 23615		77
Ram 3500 w/o mono beam	13-20	RWD	N/A	N/A		■	OEMA	OEMA	
Stock Replacement Part							23610, 23615		77
Ram 3500	10-20	4WD	N/A	N/A		■	23800(*)/ 23780, 72509 82386(16)	23800(*)/ 23780, 72509	78,78 163,169 123
Ram 3500 w/mono beam	10-13	RWD	N/A	N/A		■	23800(*)/ 23780, 72509 82386(16)	23800(*)/ 23780, 72509	78,78 163,169 123
Ram 3500	03-09	4WD	N/A	N/A		■	23800(*)/ 23780, 72509 82385(16)	23800(*)/ 23780, 72509	78,78 163,169 123
Ram 3500 w/mono beam	03-09	RWD	N/A	N/A		■	23800(*)/ 23780, 72509 82385(16)	23800(*)/ 23780, 72509	78,78 163,169 123
Ram 3500 w/o mono beam	03-12	RWD	N/A	N/A		■	OEMA	OEMA	
Ram 3500	00-02	4WD	N/A	N/A		■	23710(*)/ 23780, 72509 82385(16)	23710(*)/ 23780, 72509	78,78 163,169 123
Ram 3500 w/mono beam	00-02	RWD	N/A	N/A		■	23710(*)/ 23780, 72509 82385(16)	23710(*)/ 23780, 72509	78,78 163,169 123
Ram 3500	94-99	4WD	N/A	N/A		■	23130(*)/ 88830, 77880 24130/74500 82395(16)	23130(*)/ 88830, 77880 24130/74500	75,75 175,171 79/170 124

Applications

CAR/MINI-VAN/SUV/TRUCK APPLICATIONS

DODGE/RAM-cont.

REAR

FRONT

Model/Body Style	Year	Drive Type	CAMBER/TOOL	TOE/TOOL	Page	Thrust Plate	CASTER/TOOL	CAMBER/TOOL	Page
Ram 3500 w/mono beam	94-99	RWD	N/A	N/A		■	23130(*)/ 88830, 77880 24130/74500 82395(16)	23130(*)/ 88830, 77880 24130/74500	75,75 175,171 79/170 124
Ram 3500 w/o mono beam	94-02	RWD	N/A	N/A		■	OEMA/8286	OEMA/8286	163,163
Ram 4500 / 5500	08-18	RWD/4WD	N/A	N/A		■	N/A	23850(*)/88360	78/175
Ramcharger AD150	90-96	RWD	N/A	N/A		■	OEMA/8286	OEMA/8286	163,163
Ramcharger	74-87	RWD	N/A	N/A			OEMA 83160	OEMA 83160	124,124
Ramcharger	74-87	4WD	N/A	N/A			23000(*)/4169	23000(*)/4169	74/163
Ramcharger AD150	72-89	RWD	N/A	N/A		■	OEMA 83160	OEMA 83160	124,124
Rampage	82-84	FWD	75200(1)	75200(1)	116,116		N/A	OEMA 83170/85130	125/173
Shadow	87-94	FWD	75200(1)	75200(1)	116,116		N/A	OEMA 83170/85130	125/173
Spirit	89-96	FWD	75200(1)	75200(1)	116,116		N/A	OEMA 83170/85130	125/173
Sprinter 2500	07-09	RWD	N/A	N/A		■	N/A	35077	84
Sprinter 2500	03-06	RWD	N/A	N/A		■	N/A	35075, 35076	84,84
Sprinter 3500	07-09	RWD	N/A	N/A			N/A	35077	84
Sprinter 3500	03-06	RWD	N/A	N/A			N/A	35075, 35076	84,84
Stealth	91-96	FWD/AWD	OEMA	OEMA			N/A	81250	117
Stratus4Dr.	04-06	FWD	67025	OEMA	87		N/A	67180/40920	89/165
Stratus 2Dr. 73400 must be used with 73415	01-05	FWD	73400+73415(7) 73600, 73620(8)	OEMA	115,115 115,115		N/A	81280 82120/85130	117 122/173
Stratus 4Dr.	95-03	FWD	OEMA	OEMA			N/A	67180/40920	89/165
Viper	13-17	RWD	OEMA	OEMA			OEMA	OEMA	
Viper	94-10	RWD	OEMA	OEMA			OEMA	OEMA	
W100 W150 AW150 Truck	72-93	4WD	N/A	N/A		■	23000(*)/4169	23000(*)/4169	74/163
W200 W250 Truck w/ Dana 44	72-93	4WD	N/A	N/A			23000(*)/4169	23000(*)/4169	74/163
W200 W250 Truck w/ Dana 60	72-93	4WD	N/A	N/A		■	88940	88940	134,134
W300 W350 Truck w/ Dana 60	75-93	4WD	N/A	N/A		■	Axle Wedges 88940	88940	144,134 134
W300 W350 Truck	60-93	4WD	N/A	N/A		■	Axle Wedges	N/A	144
EAGLE									
Medallion	88-89	FWD	75200(1)	75200(1)	116,116		N/A	81280 82120/85130	117 122/173
Premier	88-92	FWD	75200(1)	75200(1)	116,116		N/A	81280 82120/85130	117 122/173
Summit SW	92-96	FWD/AWD	N/A	OEMA			N/A	81250	117
Summit	89-96	FWD	N/A	N/A			N/A	81250	117
Talon 73400 must be used with 73415	95-98	FWD/AWD	73400+73415(7) 73600, 73620(8)	OEMA	115,115 115,115		N/A	67170/40920 67370(8)	89/165 92/165
Talon	90-94	AWD	OEMA	OEMA			N/A	81250	117
Talon	90-94	FWD	N/A	N/A			N/A	81250	117
Vision	93-97	FWD	67020	OEMA	WB		N/A	81280 82120/85130	117 122/173
FIAT									
124 Spider	17-20	RWD	OEMA	OEMA			OEMA	OEMA	
500	12-19	FWD	71770(*)	71770(*)	104,104		N/A	81240	117
500x	16-20	FWD/AWD	81250	N/A	117		N/A	81250	117
500L	14-20	FWD	N/A	N/A			N/A	81250	117

Applications

Alignment Parts

Heavy Duty

OE Replacement

Racing/Builders

Tools

Brake and CV

Gear/Index

CAR/MINI-VAN/SUV/TRUCK APPLICATIONS

FORD			REAR			Thrust Plate	FRONT		Page
Model/Body Style	Year	Drive Type	CAMBER/TOOL	TOE/TOOL	Page		CASTER/TOOL	CAMBER/TOOL	
Aerostar	86-97	RWD/4WD	N/A	N/A			47700(*)	47700(*)	84,84
Aspire	95-97	FWD	75200(1)	75200(1)	116,116		N/A	OEMA 81250	117
Bronco	80-96	4WD	N/A	N/A		■	23100(*)/ 77880, 88830 24130/74500	23100(*)/ 77880, 88830 24130/74500	75,75 171,175 79,170
Bronco	71-79	4WD	N/A	N/A		■	23000(*)/4169	23000(*)/4169	74/163
Bronco II Dana 35 (Late 1990)	90-90	4WD	N/A	N/A		■	23180(*)/87175 77880, 88830 24180/ 74400, 74500	23180(*)/87175 77880, 88830 24180/ 74400, 74500	75/173 171,175 79,79 170,170
Bronco II Dana 35 (Late 1990)	89-90	RWD	N/A	N/A		■	23180(*)/87175 77880, 88830 24180/ 74400, 74500	23180(*)/87175 77880, 88830 24180/ 74400, 74500	75/173 171,175 79,79 170,170
Bronco II	84-88	RWD	N/A	N/A		■	N/A	24160/74400	79/170
Bronco II Dana 28 (Early 1990)	83-90	4WD	N/A	N/A		■	24120/74500	24120/74500	79/170
C-Max	13-18	FWD	67420	OEMA	93		N/A	OEMA	
Contour	95-00	FWD	N/A	OEMA			89675	89675	WB
Crown Victoria	03-12	RWD	N/A	N/A			OEMA	OEMA 87365/ 85130,02099	132 173,180
Crown Victoria	92-02	RWD	N/A	N/A			OEMA	OEMA/88325	174
Crown Victoria	80-91	RWD	N/A	N/A			OEMA	OEMA	
E-150	92-14	RWD	N/A	N/A		■	23180(*)/87175 77880, 88830 24180/ 74400,74500 87280(26)	23180(*)/87175 77880, 88830 24180/ 74400,74500	75/173 171,175 79,79 170,170 131
E-150 w/king pins	65-90	RWD	N/A	N/A		■	N/A	N/A	
E-250,E-350,E-450	92-20	RWD	N/A	N/A		■	23180(*)/87175 77880, 88830 24180/ 74400,74500 87280(26)	23180(*)/87175 77880, 88830 24180/ 74400,74500	75/173 171,175 79,79 170,170 131
E-250,E-350,E-450 w/king pins	65-90	RWD	N/A	N/A		■	N/A	N/A	
EcoSport	18-20	FWD/AWD	N/A	OEMA			N/A	81250	117
Edge	15-20	FWD/AWD	N/A	OEMA			N/A	81280	117
Edge	07-14	FWD/AWD	OEMA	OEMA			N/A	81280	117
Escape Inc. Hybrid	13-19	FWD/AWD	67420	OEMA	93		N/A	OEMA	
Escape Inc. Hybrid	01-12	FWD/AWD	67285/37995	OEMA	97/164		OEMA	OEMA 81250	117
Escort	97-04	FWD	81250	OEMA	117		OEMA	OEMA 81250	117
Escort	91-96	FWD	81250	OEMA 67070	117 WB		OEMA	OEMA 81250	117
Escort	81-90	FWD	81250	OEMA	117		N/A	N/A	
Excursion	00-05	RWD	N/A	N/A		■	23180(*)/87175 77880, 88830 24180/ 74400,74500	23180(*)/87175 77880, 88830 24180/ 74400,74500	75/173 171,175 79,79 170,170
Excursion	00-05	4WD	N/A	N/A		■	23130(*)/87175 77880, 88830 24130/74500	23130(*)/87175 77880, 88830 24130/74500	75/173 171,175 170,170
Expedition	18-20	RWD/4WD	OEMA	OEMA			N/A	N/A	

Applications

CAR/MINI-VAN/SUV/TRUCK APPLICATIONS

FORD-cont.			REAR			Thrust Plate	FRONT		
Model/Body Style	Year	Drive Type	CAMBER/TOOL	TOE/TOOL	Page		CASTER/TOOL	CAMBER/TOOL	Page
Expedition	07-17	RWD/4WD	OEMA 67275 86690	OEMA	90 131	OEMA 25680 86250, 86252	OEMA 25680 86250, 86252	82,82 127,127	
Expedition	03-06	RWD/4WD	86680	OEMA	131	86640/ 83820	86640/ 83820	131/ 172	
Expedition	97-02	RWD/4WD	N/A	N/A		■ 87385	87385	132,132	
Explorer	11-19	RWD/4WD	OEMA 84130	OEMA	126	N/A	81280	117	
Explorer Sport Trac	07-10	RWD/4WD	OEMA	OEMA		OEMA	OEMA		
Explorer	06-10	RWD/4WD	OEMA	OEMA		OEMA	OEMA		
Explorer	04-05	4WD	86180	OEMA	127	86140	86140	127,127	
Explorer	02-03	4WD	86180	OEMA	127	86140	26012, 26014 86140	127,83,83 127	
Explorer 2 door 'Sport'	02-03	RWD/4WD	N/A	N/A		■ 87310 87500	87310 87500	131,131 133,133	
Explorer	02-05	RWD	86180	OEMA	127	86140	86140	127,127	
Explorer	01-01	RWD	N/A	N/A		■ 87310 87500	87310 87500	131,131 133,133	
Explorer	01-01	4WD	N/A	N/A		■ 87310 87500	26012, 26014 87310 87500	131,83,83 133,131 133	
Explorer Sport Trac	01-05	RWD	N/A	N/A		■ 87310 87500	87310 87500	131,131 133,133	
Explorer Sport Trac	01-05	4WD	N/A	N/A		■ 87310 87500	26012, 26014 87310 87500	131,83,83 133,13 133	
Explorer	95-00	RWD/4WD	N/A	N/A		■ 87310 87500	87310 87500	131,131 133,133	
Explorer	91-94	RWD/4WD	N/A	N/A		■ 23180(*)/ 87175 77880, 88830 24180/ 74400,74500	23180(*)/ 87175 77880, 88830 24180/ 74400,74500	75/ 173 171,175 79,79 170,170	
EXP	82-88	FWD	81250	OEMA	117	N/A	N/A		
F-100 w/ ball joint suspension	80-83	RWD/4WD	N/A	N/A		■ N/A	24160/ 74400	79/ 170	
F-100	66-79	4WD	N/A	N/A		■ 23000(*)/ 4169	23000(*)/ 4169	74/ 163	
F-100 w/ king pin suspension	65-83	RWD	N/A	N/A		■ N/A	N/A		
F-150 Except Raptor	04-20	RWD/4WD	86255(19)	N/A	128	OEMA 25680 86250, 86252	OEMA 25680 86250, 86252	82,82 127,127	
F-150 Raptor	17-20	4WD	N/A	N/A		■ OEMA 86250 , 86252	OEMA 86250 , 86252	127,127	
F-150 Raptor	10-14	4WD	86255(19)	N/A	128	■ OEMA 86250 , 86252	OEMA 86250 , 86252	127,127	
F-150 Heritage	04-05	RWD/4WD	N/A	N/A		■ 87385	87385	132,132	
F-150	97-03	RWD/4WD	N/A	N/A		■ 87385	87385	132,132	
F-150	87-96	RWD	N/A	N/A		■ 23180(*)/ 87175 77880, 88830 24180/ 74400, 74500 87280	23180(*)/ 87175 77880, 88830 24180/ 74400, 74500	75/ 173 171,175 79,79 170,170 131	
F-150	82-86	RWD	N/A	N/A		■ N/A	24160/ 74400	79/ 170	
F-150	80-96	4WD	N/A	N/A		■ 23100(*)/ 77880, 88830 24130/ 74500	23100(*)/ 77880, 88830 24130/ 74500	74,74 171,175 79/ 170	
F-150	66-79	4WD	N/A	N/A		■ 23000(*)/ 4169	23000(*)/ 4169	74/ 163	
F-150 King Pin	65-90	RWD	N/A	N/A		■ N/A	N/A		
F-250 Solid Axle - Coil Spring	05-20	RWD/4WD	N/A	N/A		■ 23220(*) 23268, 23269 24220/ 74600	23220(*) 23268, 23269 24220/ 74600	76,76 76,76 79/ 170	
F-250 Solid Axle - Leaf Spring	99-04	RWD/4WD	N/A	N/A		■ 23130(*)/ 77880, 88830 24130/ 74500	23130(*)/ 77880, 88830 24130/ 74500	75,75 171,175 79/ 170	

Applications

Alignment Parts

Heavy Duty

OE Replacement

Racing/Builders

Tools

Brake and CV

Gear/Index

CAR/MINI-VAN/SUV/TRUCK APPLICATIONS

FORD-cont.			REAR			Thrust Plate	FRONT		
Model/Body Style	Year	Drive Type	CAMBER/TOOL	TOE/TOOL	Page		CASTER/TOOL	CAMBER/TOOL	Page
F-250 Twin I-Beam	98-20	RWD	N/A	N/A		■ 23180(*)/87175 77880, 88830 24180/ 74400, 74500	23180(*)/87175 77880, 88830 24180/ 74400, 74500	75/173 171,175 79,79 170,170	
F-250L/D	97-99	RWD/4WD	N/A	N/A		■ 87385	87385	132,132	
F-250	87-98	RWD	N/A	N/A		■ 23180(*)/87175 77880, 88830 24180/ 74400, 74500	23180(*)/87175 77880, 88830 24180/ 74400, 74500	75/173 171,175 79,79 170,170	
F-250	82-86	RWD	N/A	N/A		■ N/A	N/A		
F-250	80-98	4WD	N/A	N/A		■ 23100(*)/ 77880, 88830 24130/74500	23100(*)/ 77880, 88830 24130/74500	74,74 171,175 79/170	
F-250 Dana 60	74-79	4WD	N/A	N/A		■ 88940	88940	134,134	
F-250	73-79	4WD	N/A	N/A		■ Axle Wedges 23000(*)/4169	23000(*)/4169	144,74/163 74/163	
F-250 King Pin	65-90	RWD	N/A	N/A		■ N/A	N/A		
F-350 Solid Axle - Coil Spring	05-20	RWD/4WD	N/A	N/A		■ 23220(*) 23268, 23269 24220/74600	23220(*) 23268, 23269 24220/74600	76,76 76,76 79/170	
F-350 Solid Axle - Leaf Spring	99-04	RWD/4WD	N/A	N/A		■ 23130(*)/ 77880, 88830 24130/74500	23130(*)/ 77880, 88830 24130/74500	75,75 171,175 79/170	
F-350 Twin I-Beam	98-20	RWD	N/A	N/A		■ 23180(*)/87175 77880, 88830, 24180/ 74400, 74500	23180(*)/87175 77880, 88830, 24180/ 74400, 74500	75/173 171,175 79,79 170,170	
F-350 Crew Cab	92-98	4WD	N/A	N/A		■ 23130(*)/ 77880, 88830 24130/74500 87275	23130(*)/ 77880, 88830 24130/74500	75,75 171,175 79/170 WB	
F-350	87-98	RWD	N/A	N/A		■ 23180(*)/87175 77880, 88830, 24180/ 74400, 74500	23180(*)/87175 77880, 88830, 24180/ 74400, 74500	75/173 171,175 79,79 170,170	
F-350	82-86	RWD	N/A	N/A		■ N/A	N/A		
F-350	80-98	4WD	N/A	N/A		■ 23100(*)/ 77880, 88830 24130/74500	23100(*)/ 77880, 88830 24130/74500	75,75 171,175 79/170	
F-350 Dana 60	74-91	4WD	N/A	N/A		■ 88940	88940	134,134	
F-350	73-79	4WD	N/A	N/A		■ Axle Wedges	N/A	144	
F-350 King Pin	65-90	RWD	N/A	N/A		■ N/A	N/A		
F-450 w/ 10 lug axles	05-20	RWD/4WD	N/A	N/A		■ 23230(*) 24230/74600	23230(*) 24230/74600	76,76 79/170	
F-450 w/ 8 lug axles	05-20	RWD/4WD	N/A	N/A		■ 23220(*) 23268, 23269 24220/74600	23220(*) 23268, 23269 24220/74600	76,76 76,76 79,170	
F-450	99-04	RWD/4WD	N/A	N/A		■ 23130(*)/ 77880, 88830 24130/74500	23130(*)/ 77880, 88830 24130/74500	75,75 171,175 79/170	
F-550	05-20	RWD/4WD	N/A	N/A		■ 23230(*) 24230/74600	23230(*) 24230/74600	76,76 79/170	
F-550	99-04	RWD/4WD	N/A	N/A		■ 23130(*)/ 77880, 88830 24130/74500	23130(*)/ 77880, 88830 24130/74500	75,75 171,175 79/170	
Fairlane 94009, upper ball joint pg. 157	66-69	RWD	N/A	N/A		OEMA 94210	OEMA 94210 83160	135,135 124	

CAR/MINI-VAN/SUV/TRUCK APPLICATIONS

FORD-cont.			REAR			Thrust Plate	FRONT		
Model/Body Style	Year	Drive Type	CAMBER/TOOL	TOE/TOOL	Page		CASTER/TOOL	CAMBER/TOOL	Page
Fairmont	78-83	RWD	N/A	N/A		N/A	OEMA 81280 82120/ 85130	117 122/ 173	
Falcon 94009, upper ball joint pg. 157	66-69	RWD	N/A	N/A		OEMA 94210	OEMA 94210 83160	135,135 124	
Falcon 94009, upper ball joint pg. 157	64-65	RWD	N/A	N/A		47700(*) 94215 94220	47700(*) 94215	84,84 135,135 135	
Falcon	60-63	RWD	N/A	N/A		47700(*)	47700(*)	84,84	
Festiva	88-94	FWD	75200(1)	75200(1)	116,116	N/A	OEMA 81250	117	
Fiesta	11-19	FWD	N/A	N/A		N/A	81250	117	
Fiesta	78-80	FWD	N/A	N/A		N/A	N/A		
Five Hundred	05-07	AWD	67690	OEMA	101	N/A	OEMA		
Stock Replacement Part			12710		151				
Five Hundred	05-07	FWD	71760(*)	OEMA	104	N/A	OEMA		
Flex	13-19	FWD/AWD	OEMA 84130	OEMA	126	N/A	N/A		
Flex	09-12	FWD/AWD	OEMA 84130	OEMA	126	N/A	OEMA		
Focus Inc. ST/RS	12-18	FWD/AWD	67420	OEMA	93	N/A	N/A		
Focus Inc. SVT	00-11	FWD	67420 81310	OEMA	93 118	81320	81320	118,118	
Freestar	04-07	FWD	N/A	N/A		OEMA/ 68670	OEMA 89685/ 68670	168 134/ 168	
Freestyle	05-07	AWD	67690	OEMA	101	N/A	OEMA		
Stock Replacement Part			12710		151				
Freestyle	05-07	FWD	71760(*)	OEMA	104	N/A	OEMA		
Fusion Inc. Hybrid	13-20	AWD	N/A	OEMA		N/A	81280	117	
Fusion Inc. Hybrid	13-20	FWD	67680	OEMA	101	N/A	81280	117	
Fusion Inc. Hybrid	06-12	FWD/AWD	OEMA 67425	OEMA	96	N/A	67115/ 40920	89/ 165	
Granada	81-82	RWD	N/A	N/A		N/A	OEMA 81280 82120/ 85130	117 122/ 173	
Granada	75-80	RWD	N/A	N/A		OEMA	OEMA 83160	124	
LTD	83-86	RWD	N/A	N/A		N/A	OEMA 81280 82120/ 85130	117 122/ 173	
Maverick 94009, upper ball joint pg. 157	70-77	RWD	N/A	N/A		OEMA 94210	OEMA 94210 83160	135,135 124	
Mustang	15-20	RWD	OEMA 72360/ 74400 72370/ 74400	OEMA 72360/ 74400 72380	112/ 170 112/ 170	N/A	81280	117	
Stock Replacement Part			12050		150				
Mustang	11-14	RWD	N/A	72045 72345	106 111	72350 72355	72350 81260	111 111,117	
Mustang	05-10	RWD	N/A	72045 72345	106 111	72040 72350 72355	72040 72350 81260	105,105 111,111 111,117	
Mustang Cobra	99-04	RWD	OEMA	OEMA		OEMA/ 85130 72060	OEMA 72060 81280 82120/ 85130	173 107,107 117 122/ 173	
Stock Replacement Part			72062		153				
Mustang	94-04	RWD	N/A	N/A		72060	OEMA 72060 81280 82120/ 85130	107 107 117 122/ 173	

Applications

Alignment Parts

Heavy Duty

OE Replacement

Racing/Builders

Tools

Brake and CV

Gear/Index

CAR/MINI-VAN/SUV/TRUCK APPLICATIONS

FORD-cont.			REAR			Thrust Plate	FRONT		
Model/Body Style	Year	Drive Type	CAMBER/TOOL	TOE/TOOL	Page		CASTER/TOOL	CAMBER/TOOL	Page
Mustang	79-93	RWD	N/A	N/A		N/A	OEMA 81280 82120/85130	117 122/173	
Mustang II	74-78	RWD	N/A	N/A		OEMA 97260	OEMA 97260	140,140	
Mustang <i>94009, upper ball joint pg. 157</i>	67-73	RWD	N/A	N/A		OEMA 94210	OEMA 94210 83160	135,135 124	
Mustang <i>94009, upper ball joint pg. 157</i>	64-66	RWD	N/A	N/A		47700(*) 94215 94220	47700(*) 94215	84,84 135,135 135	
Police Interceptor Sedan	13-18	FWD/AWD	OEMA 84130	OEMA	126	N/A	N/A		
Police Interceptor Utility	13-18	RWD/4WD	OEMA 84130	OEMA	126	N/A	81280	117	
Probe	89-97	FWD	81250	OEMA	117	OEMA	OEMA 81250	117	
Ranchero <i>94009, upper ball joint pg. 157</i>	66-71	RWD	N/A	N/A		OEMA 94210	OEMA 94210 83160	135,135 124	
Ranchero <i>94009, upper ball joint pg. 157</i>	64-65	RWD	N/A	N/A		47700(*) 94215 94220	47700(*) 94215	84,84 135,135 135	
Ranger	19-20	RWD/4WD	N/A	N/A		OEMA 25670	OEMA 25670	82,82	
Ranger	03-11	RWD	N/A	N/A		■ 87500	87500	133,133	
Ranger	03-11	4WD	N/A	N/A		■ 87500	26012, 26014 87500	133,83,83 133	
Ranger	01-02	RWD/4WD	N/A	N/A		■ 87500	87500	133,133	
Ranger	98-00	RWD/4WD	N/A	N/A		■ 87310 87500	87310 87500	131,131 133,133	
Ranger Dana 35 Twin I-Beam	90-97	4WD	N/A	N/A		■ 23180(*)/87175 77880, 88830 24180/ 74400, 74500	23180(*)/87175 77880, 88830 24180/ 74400, 74500	75/173 171,175 79,79 170,170	
Ranger	89-97	RWD	N/A	N/A		■ 23180(*)/87175 77880, 88830 24180/ 74400, 74500 87280	23180(*)/87175 77880, 88830 24180/ 74400, 74500	75/173 171,175 79,79 170,170 131	
Ranger	83-88	RWD	N/A	N/A		■ 87275	24160/74400	WB,79/170	
Ranger Dana 28	83-89	4WD	N/A	N/A		■ 24120/74500	24120/74500	79/170	
Taurus	13-19	FWD/AWD	OEMA 84130	OEMA	126	N/A	N/A		
Taurus	10-12	FWD/AWD	OEMA 84130	OEMA	126	N/A	OEMA		
Taurus	08-09	AWD	67690	OEMA	101	N/A	OEMA		
Stock Replacement Part			12710		151				
Taurus	08-09	FWD	71760(*)	OEMA	104	N/A	OEMA		
Taurus X	08-09	AWD	67690	OEMA	101	N/A	OEMA		
Stock Replacement Part			12710		151				
Taurus X	08-09	FWD	71760(*)	OEMA	104	N/A	OEMA		
Taurus Wagon	96-05	FWD	87350/85130	OEMA/ 97650	132/173 175	OEMA/68670	OEMA 89635/68670	168 134/168	
Taurus Sedan <i>87325 Intended for use on OE adjusters - NOT intended for aftermarket parts</i>	86-07	FWD	87330/ 8370, 87320	OEMA/87325 87330/ 8370, 87320	132/174 163/132 163,173	OEMA/68670	OEMA 89635/68670	168 134/168	

CAR/MINI-VAN/SUV/TRUCK APPLICATIONS

FORD-cont.

FORD-cont.			REAR			Thrust Plate	FRONT		
Model/Body Style	Year	Drive Type	CAMBER/TOOL	TOE/TOOL	Page		CASTER/TOOL	CAMBER/TOOL	Page
Taurus Wagon	86-95	FWD	87350/85130	OEMA/ 97650	132/173 175		OEMA/68670	OEMA/68670	138,168
Tempo	86-94	FWD/AWD	81250	OEMA/87325	117/174		N/A	N/A	
Tempo	84-85	FWD	81250	N/A	117		N/A	N/A	
Thunderbird	02-06	RWD	N/A	OEMA			OEMA 87540	OEMA 87540	134
Stock Replacement Part			87550		153				
Thunderbird	89-97	RWD	OEMA	OEMA			OEMA 87535	OEMA 87535	133
Thunderbird	80-88	RWD	N/A	N/A			N/A	OEMA 81280 82120/85130	117 122/173
Thunderbird	64-66	RWD	N/A	N/A			47700(*)	47700(*)	84,84
Torino	66-71	RWD	N/A	N/A			OEMA 94210	OEMA 94210 83160	135,135 124
94009, upper ball joint pg. 157									
Transit	15-20	RWD	N/A	N/A			OEMA	OEMA	
Transit Connect	14-20	FWD	N/A	N/A			N/A	N/A	
Transit Connect	10-13	FWD	75600	75600	116,116		81320	81320	118,118
Windstar	94-03	FWD	75400(1)	75400(1)	116,116		OEMA	OEMA 89685	134

FREIGHTLINER

<i>See our Heavy Duty Section</i>		<i>pages 141-149</i>							
Sprinter 2500	07-18	RWD	N/A	N/A		■	N/A	35077	84
Sprinter 2500	02-05	RWD	N/A	N/A		■	N/A	35075, 35076	84,84
Sprinter 3500	07-18	RWD	N/A	N/A			N/A	35077	84
Sprinter 3500	02-05	RWD	N/A	N/A			N/A	35075, 35076	84,84

GENESIS

G70	19-20	RWD/AWD	OEMA	OEMA 84085	125		N/A	N/A	
G80	17-20	RWD/AWD	OEMA	OEMA 84085	125		N/A	N/A	
G90	17-19	RWD/AWD	OEMA	OEMA 84085	125		N/A	N/A	

GEO

Metro	89-97	FWD	N/A	OEMA			N/A	81250	117
Prizm	89-97	FWD	75600(1) 75800(1)	75600(1) 75800(1)	116,116 116,116		N/A	OEMA 81260	117
Spectrum	89-90	FWD	75200(1)	75200(1)	116,116		N/A	81250	117
Storm	90-93	FWD	81250	OEMA	117		N/A	81250	117
Tracker	89-97	RWD/4WD	N/A	N/A			N/A	81250	117

GMC

1500,2500,3500 1999/2000 'Classic' only)	88-00	RWD/4WD	N/A	N/A		■	OEMA 83790/74910 87400/74910	OEMA 83790/74910 87400/74910 86350(2)/72509	125/170 132/170 129/169
4500,5500 Topkick	03-09	RWD	N/A	N/A			Axle Wedges	N/A	144
4500,5500 Topkick	03-09	4WD	N/A	N/A			Axle Wedges 23230(*), 24230/74600	23230(*), 24230/74600	144,76 76,79/170
Acadia Limited	17-17	FWD/AWD	OEMA 82105, 82106	OEMA 82105	121,121		N/A	81280	117
Stock Replacement Part			15647		158				
Acadia	17-20	FWD/AWD	OEMA	OEMA			N/A	81250	117
Acadia	07-16	FWD/AWD	OEMA 82105, 82106	OEMA 82105	121,121		N/A	81280	117
Stock Replacement Part			15647		158				
Canyon 45945 for use on OE cams only	15-20	RWD/4WD	N/A	N/A			OEMA/45945 86321, 86326 86376	OEMA/45945 86321, 86326 86376	167,167 128,128 129,129

CAR/MINI-VAN/SUV/TRUCK APPLICATIONS

GMC-cont.			REAR			Thrust Plate	FRONT		
Model/Body Style	Year	Drive Type	CAMBER/TOOL	TOE/TOOL	Page		CASTER/TOOL	CAMBER/TOOL	Page
Colorado 45940 for use on OE cams only	04-12	RWD/4WD	N/A	N/A		■ OEMA/ 45940 45938 86320, 86325 86360 86375	OEMA/ 45940 45938 86320, 86325 86360 86375	167,167 167,167 128,128 129,129 129,129	
C15, C1500 Pickup/Suburban	73-87	RWD	N/A	N/A		47700(*) 97180	47700(*) 97180	84,84 140,140	
C15, C1500 Pickup/Suburban	65-82	RWD	N/A	N/A		47700(*)	47700(*)	84,84	
C25, C35, C2500, C3500 Pickup/Suburban	65-87	RWD	N/A	N/A		47700(*)	47700(*)	84,84	
Envoy	02-09	RWD/4WD	N/A	N/A		OEMA/ 83785	OEMA/ 83785	172,172	
G15, G1500 Van	75-95	RWD	N/A	N/A		47700(*) 97180	47700(*) 97180	84,84 140,140	
G15, G1500 Van	71-74	RWD	N/A	N/A		47700(*)	47700(*)	84,84	
G25 G35 Van	71-96	RWD	N/A	N/A		47700(*)	47700(*)	84,84	
Jimmy Full Size	88-91	RWD/4WD	N/A	N/A		■ OEMA 83790/ 74910 87400/ 74910	OEMA 83790/ 74910 87400/ 74910 86350(2)/ 72509	125/ 170 132/ 170 127/ 169	
Jimmy S-15 <i>94006, upper ball joint pg. 157</i> <i>94017, 1/2" ext upper ball joint pg.157</i>	82-04	RWD	N/A	N/A		47700(*) 97140 95336(22)	47700(*) 97140	84,84 138,138 136	
Jimmy S-15	82-04	4WD	N/A	N/A		OEMA 83710	OEMA 83710	125,125	
Jimmy C5	69-91	RWD	N/A	N/A		■ 47700(*)	47700(*)	84,84	
Jimmy K5	69-91	4WD	N/A	N/A		■ 23000(*)/ 4169	23000(*)/ 4169	74/136	
K10, K15, K20, K25 Pickup/Suburban	70-87	4WD	N/A	N/A		■ 23000(*)/ 4169	23000(*)/ 4169	74/136	
K30, K35	58-87	4WD	N/A	N/A		■ Axle Wedges	23000(*)/ 4169	74/136	
K30, V30 Dana 60	88-93	4WD	N/A	N/A		■ Axle Wedges 88940	88940	144, 134 134	
Safari Full Size	90-05	AWD	N/A	N/A		■ OEMA 83790/ 74910 87400/ 74910	OEMA 83790/ 74910 87400/ 74910	125/ 170 132/ 170	
Safari	85-05	RWD	N/A	N/A		47700(*)	47700(*)	84,84	
Savana Van 45940 for use on OEM style cams only.	03-20	RWD/4WD	N/A	N/A		■ OEMA/ 45940 86320, 86325 86370, 86375	OEMA/ 45940 86320, 86325 86370, 86375 86350 (33)/ 72509	167,167 128,128 129,129 129/ 169	
Savana Van	96-02	RWD	N/A	N/A		■ OEMA 83790/ 74910 87400/ 74910	OEMA 83790/ 74910 87400/ 74910	125/ 170 132/ 170	
Sierra 1500	19-20	RWD/4WD	N/A	N/A		OEMA	OEMA		
Sierra 1500 45940 for use on OEM style cams only.	99-18	RWD/4WD	N/A	N/A		■ OEMA/ 45940 86320, 86325 86375 86470 (thru '06)	OEMA/ 45940 86320, 86325 86375 86350/ 72509 86470 (thru '06)	167,167 128,128 129,129 130,129/ 169 130	
Sierra 1500 HD Crew Cab 45940 for use on OEM style cams only.	01-06	RWD/4WD	N/A	N/A		■ OEMA/ 45940 23960/ 72509 86320, 86325 86375	OEMA/ 45940 23960/ 72509 86320, 86325 86375 86330/ 72509	167,167 80/ 169 128,128 129,129 129/ 169	
Sierra 2500 45945 for use on OE cams only.	11-20	RWD/4WD	N/A	N/A		OEMA/ 45945 86321, 86326 86376	OEMA/ 45945 86321, 86326, 86376	167,167 128,128 129,129	

CAR/MINI-VAN/SUV/TRUCK APPLICATIONS

GMC-cont.

REAR

FRONT

Model/Body Style	Year	Drive Type	CAMBER/TOOL	TOE/TOOL	Page	Thrust Plate	CASTER/TOOL	CAMBER/TOOL	Page
Sierra 2500 <i>45940 for use on OEM style cams only.</i>	99-10	RWD/4WD	N/A	N/A		■	OEMA/ 45940 23960/ 72509 86320, 86325 86375	OEMA/ 45940 23960/ 72509 86320, 86325 86375 86330/ 72509	167,167 80/ 169 128,128 129,129 129/ 169
Sierra 2500 HD Cab/Chassis	91-02	RWD	N/A	N/A		■	Axle Wedges	N/A	144
Sierra 3500 <i>45940 for use on OEM style cams only.</i>	11-20	RWD/4WD	N/A	N/A			OEMA/ 45945 86321, 86326 86376	OEMA/ 45945 86321, 86326 86376	167,167 128,128 129,129
Sierra 3500 <i>45940 for use on OEM style cams only.</i>	99-10	RWD/4WD	N/A	N/A			OEMA/ 45940 23960/ 72509 86320, 86325 86375	OEMA/ 45940 23960/ 72509 86320, 86325 86375 86330/ 72509	167,167 80/ 169 128,128 129,129 129/ 169
Sierra 3500 HD Cab/Chassis	91-02	RWD	N/A	N/A			Axle Wedges	N/A	144
Sonoma <i>94006, upper ball joint pg. 157</i> <i>94017, 1/2" ext upper ball joint pg. 57</i>	82-04	RWD	N/A	N/A			47700(*) 97140 95336(22)	47700(*) 97140	84,84 138,138 136
Sonoma	82-04	4WD	N/A	N/A			OEMA 83710	OEMA 83710	125,125
Suburban 1500 <i>45940 for use on OEM style cams only.</i>	00-13	RWD/4WD	N/A	N/A			OEMA/ 45940 86320, 86325 86370, 86375	OEMA/ 45940 86320, 86325 86370, 86375 86350 (33)/ 72509	167,167 128,128 129,129 129/ 169
Suburban 2500 <i>45940 for use on OEM style cams only.</i>	00-13	RWD/4WD	N/A	N/A		■	OEMA/ 45940 23960/ 72509 86320, 86325 86375	OEMA/ 45940 23960/ 72509 86320, 86325 86375 86330/ 72509	167,167 80/ 169 128,128 129,129 129/ 169
Suburban Full Size	92-99	RWD/4WD	N/A	N/A		■	OEMA 83790/ 74910 87400/ 74910	OEMA 83790/ 74910 87400/ 74910 86350(2)/ 72509	125/ 170 132/ 170 129/ 169
Suburban	69-91	4WD	N/A	N/A			23000(*)/ 4169	23000(*)/ 4169	74/ 163
Suburban	65-72	RWD	N/A	N/A		■	47700(*)	47700(*)	84,84
Terrain	18-19	FWD/AWD	OEMA	OEMA			N/A	81250	117
Terrain	05-17	FWD/AWD	OEMA 87420	OEMA 87420	133,133		N/A	81260	117
Tracker	98-04	4WD	N/A	N/A			N/A	81250	117
V30 V35 Dana 60	88-93	4WD	N/A	N/A			Axle Wedges 88940	88940	144,134 134
Yukon 1500 Inc. XL <i>45940 for use on OEM style cams only.</i>	00-20	RWD/4WD	N/A	N/A		■	OEMA/ 45940 86320, 86325 86375 86470 (thru '06)	OEMA/ 45940 86320, 86325 86375 86350/ 72509 86470 (thru '06)	167,167 128,128 129,129 130,129/ 169 130
Yukon 2500 Inc. XL <i>45940 for use on OEM style cams only.</i>	00-14	RWD/4WD	N/A	N/A			OEMA/ 45940 23960/ 72509 86320, 86325 86375	OEMA/ 45940 23960/ 72509 86320, 86325 86375 86330/ 72509	167,167 80/ 169 128,128 129,129 129/ 169
Yukon Full Size	92-99	RWD/4WD	N/A	N/A			OEMA 83790/ 74910 87400/ 74910	OEMA 83790/ 74910 87400/ 74910 86350(2)/ 72509	125/ 170 132/ 170 129/ 169

HONDA

Accord	18-20	FWD	67476	OEMA	95		N/A	67381, 67382	92,92
Stock Replacement Part								12715	151
Accord <i>*67550 or 67555 must be used w/67540, 67545, 67550 to adjust setback</i>	13-17	FWD	67540/ 74920 67545(12)/ 74920 67560/ 74920	OEMA 67540/ 74920 67550/ 74920 67555/ 74920 67560/ 74920 67565/ 74920	97/ 170 97/ 170 97/ 170 97/ 170 97/ 170		N/A	OEMA	

Applications

Alignment Parts

Heavy Duty

OE Replacement

Racing/Builders

Tools

Brake and CV

Gear/Index

CAR/MINI-VAN/SUV/TRUCK APPLICATIONS

HONDA-cont.			REAR			Thrust Plate	FRONT		
Model/Body Style	Year	Drive Type	CAMBER/TOOL	TOE/TOOL	Page		CASTER/TOOL	CAMBER/TOOL	Page
Accord Crosstour <i>*67550 or 67555 must be used w/67540, 67545, 67550 to adjust setback</i>	10-15	FWD/AWD	67540/ 74920	OEMA	97/ 170	N/A	67135/40920 67330(8)/ 40920	89/ 165 92/ 165	
			67545(12)/ 74920	67540/ 74920	97/ 170				
			67560/ 74920	67550/ 74920	97/ 170				
				67555/ 74920	97/ 170				
				67560/ 74920	97/ 170				
			67565/ 74920	97/ 170					
Accord	08-12	FWD	67540/ 74920	OEMA	97/ 170	N/A	67135/40920 67330(8)/ 40920	89/ 165 92/ 165	
			67545(12)/ 74920	67540/ 74920	97/ 170				
			67560/ 74920	67550/ 74920	97/ 170				
				67555/ 74920	97/ 170				
				67560/ 74920	97/ 170				
			67565/ 74920	97/ 170					
Accord	03-07	FWD	67289/ 37995	OEMA	91/ 164	N/A	67125/40920 67320(*)/ 40920	89/ 165 92/ 165	
			67290/ 37995	67289	91/ 164 /91				
			67291/ 37995	67292	91/ 164 /91				
				67293	91				
				67295	91				
Stock Replacement Part						67075	153		
Accord	98-02	FWD	67090/ 37995	OEMA	88/ 164	84690, 84695	67125/40920 67320(8)/ 40920	89/ 165 92/ 165	
				67295	91				
			Stock Replacement Part		67075				153
Accord	90-97	FWD	67065/37995	OEMA	87/ 164	84690, 84695	67145/40920 67340(8)/ 40920	89/ 165 92/ 165	
			67265(8)/ 37995		90/ 164				
			Stock Replacement Part		67075				153
Accord	86-89	FWD	N/A	OEMA		OEMA	N/A		
Accord	80-85	FWD	N/A	OEMA		N/A	N/A		
Civic Except Type R	18-20	FWD	67467	OEMA	95	N/A	67381, 67382	92,92	
			67476		95				
			Stock Replacement Part						
Civic Type R	17-20	FWD	67476	OEMA	95	N/A	N/A		
Civic Except 5-door LX/EX	17-17	FWD	67467	OEMA	95	N/A	67381, 67382	92,92	
			67476		95				
			Stock Replacement Part						
Civic 5-door LX/EX	17-17	FWD	67467	OEMA	95	N/A	N/A		
			67476		95				
			Stock Replacement Part						
Civic	16-16	FWD	67467	OEMA	95	N/A	67381, 67382	92,92	
			67476		95				
			Stock Replacement Part						
Civic Except Si	12-15	FWD	67465/ 75980, 72509	OEMA/ 87560	94/ 171,169	N/A	81260	117	
			67466		94				
			67475		95				
			Stock Replacement Part						
Civic Si	12-15	FWD	67465/ 75980, 72509	OEMA/ 87560	94/ 171,169	N/A	81280	117	
			67466		94				
			67475		95				
			Stock Replacement Part						
Civic	06-11	FWD	67465/ 75980, 72509	OEMA/ 87560	94/ 171,169	N/A	81260	117	
			67466		94				
			67475		95				
			Stock Replacement Part						
Civic	03-05	FWD	67230	OEMA	90	N/A	81280	117	
			69300(22)/ 69330(14)		102/ 168				
			Stock Replacement Part						
Civic	01-02	FWD	67230	OEMA	90	N/A	81260	117	
			69300(22)/ 69330(14)		102/ 168				
			Stock Replacement Part						
Civic 65100, rear trailing arm bushing tool pg. 168	96-00	FWD	67030	OEMA	87	62010	62010 67135/40920 67330(8)/ 40920	WB,WB 89/ 165 92/ 165	
			69100(22)	69250	WB,WB				
			Stock Replacement Part		102				
						67245	153		

Applications
Alignment Parts
Heavy Duty
OE Replacement
Racing/Builders
Tools
Brake and CV
Gear/Index

CAR/MINI-VAN/SUV/TRUCK APPLICATIONS

HONDA-cont.

REAR			FRONT						
Model/Body Style	Year	Drive Type	CAMBER/TOOL	TOE/TOOL	Page	Thrust Plate	CASTER/TOOL	CAMBER/TOOL	Page
Civic	92-95	FWD	67030	OEMA	87		N/A	67135/40920	89/165
65100, rear trailing arm bushing tool pg. 168			69100(22)	69250	WB, WB			67330(8)/40920	92/165
Stock Replacement Part				69450	102			67245	153
Civic	88-91	FWD	67030	OEMA	87		N/A	67125/40920	89/165
65100, rear trailing arm bushing tool pg. 168			69100(22)	69250	WB, WB			67320(8)/40920	92/165
Stock Replacement Part				69450	102			67075	153
Civic SW & 4WD	88-91	FWD/4WD	67030	OEMA	87		N/A	67125/40920	89/165
65100, rear trailing arm bushing tool pg. 168			69100(22)		WB			67320(8)/40920	92/165
Stock Replacement Part								67075	153
Civic	80-87	FWD	N/A	N/A			N/A	N/A	
Civic del Sol	92-97	FWD	67030	OEMA	87		N/A	67135/40920	89/165
65100, rear trailing arm bushing tool pg. 168			69100(22)	69250	WB, WB			67330(8)/40920	92/165
Stock Replacement Part				69450	102			67245	153
Clarity	17-19	FWD	N/A	OEMA			N/A	OEMA	
Crosstour	10-15	FWD/AWD	67540/74920	OEMA	97/170		N/A	67135/40920	89/165
*67550 or 67555 must be used w/67540, 67545, 67550 to adjust setback			67545(12)/74920	67540/74920	97/170			67330(8)/40920	92/165
			67560/74920	67550/74920	97/170				
				67555/74920	97/170				
				67560/74920	97/170				
				67565/74920	97/170				
CR-V	17-20	FWD/AWD	67476	OEMA	95		N/A	67381, 67382	92,92
Stock Replacement Part								12715	151
CR-V	07-16	FWD/AWD	67580	OEMA/87560	174		N/A	81280	117
CR-V	02-06	FWD/AWD	67430	OEMA	94		N/A	81280	117
			69400(22)/69330(14)		102/168				
CR-V	97-01	FWD/AWD	67030	OEMA	87		N/A	67135/40920	89/165
				69250	WB			67330(8)/40920	92/165
Stock Replacement Part				69450	102			67245	153
CR-Z	11-16	FWD	N/A	N/A			N/A	81260	117
CRX	88-92	FWD	67030	OEMA	87		N/A	67125/40920	89/165
65100, rear trailing arm bushing tool pg. 168			69100(22)	69250	WB, WB			67320(8)/40920	92/165
Stock Replacement Part				69450	102			67075	153
CRX	84-87	FWD	N/A	N/A			N/A	N/A	
Element	03-11	FWD/AWD	67430	OEMA/87560	94/174		N/A	81280	117
			69400(22)/69330(14)		102/168				
Fit	15-19	FWD	71790(*)	71790(*)	105,105		N/A	81260	117
Fit	09-14	FWD	N/A	N/A			N/A	81260	117
Fit	06-08	FWD	75600	75600	116,116		N/A	81260	117
			75800	75800	116,116				
HR-V	16-20	FWD/AWD	N/A	N/A			N/A	81280	117
Insight	19-20	FWD	67467	OEMA	95		N/A	N/A	
			67476		95				
Insight	10-14	FWD	N/A	N/A			N/A	81260	117
Insight	01-06	FWD	N/A	N/A			N/A	81260	117
Odyssey	18-20	FWD	N/A	OEMA			N/A	N/A	
Odyssey	05-17	FWD	67590/37995	OEMA	98/164		N/A	81280	117
Odyssey	99-04	FWD	67290/37995	OEMA	91/164		N/A	81280	117
Odyssey	95-98	FWD	67155/40920	OEMA	89/165		OEMA	67125/40920	89/165
Stock Replacement Part							84690, 84695	67320(8)/40920	92/165
								67075	153
Passport	19-20	FWD/AWD	N/A	OEMA			N/A	N/A	
Passport	94-02	FWD/AWD	N/A	N/A			47700(*)	47700(*)	84,84
Pilot	16-20	FWD/AWD	23450/37995	OEMA	77/164		N/A	N/A	
Pilot	09-15	FWD/AWD	67570/37995	OEMA	98/164		N/A	81295	117
Pilot	03-08	FWD/AWD	67290/37995	OEMA	91/164		N/A	81280	117

Applications

Alignment Parts

Heavy Duty

OE Replacement

Racing/Builders

Tools

Brake and CV

Gear/Index

CAR/MINI-VAN/SUV/TRUCK APPLICATIONS

HONDA-cont.			REAR			Thrust Plate	FRONT		
Model/Body Style	Year	Drive Type	CAMBER/TOOL	TOE/TOOL	Page		CASTER/TOOL	CAMBER/TOOL	Page
Prelude	97-02	FWD	67165/40920 67360(8)/40920	OEMA	89/165 92/165	N/A	67135/40920 67330(8)/40920	89/165 92/165	
Stock Replacement Part							67245	153	
Prelude SH	97-02	FWD	67165/40920 67360(8)/40920	OEMA	89/165 92/165	N/A	67155/40920 67350(8)/40920	89/165 92/165	
Stock Replacement Part							67245	153	
Prelude 4WS	92-94	FWD	OEMA	OEMA		OEMA	67165/40920 67360(8)/40920	89/165 92/165	
Prelude	92-96	FWD	67165/40920 67360(8)/40920	OEMA	89/165 92/165	N/A	67165/40920 67360(8)/40920	89/165 92/165	
Prelude 4WS	88-91	FWD	OEMA	OEMA		OEMA	OEMA		
Prelude	83-91	FWD	N/A	OEMA		OEMA	OEMA		
Prelude	79-82	FWD	N/A	N/A		OEMA	N/A		
Ridgeline	17-20	FWD/AWD	23450/37995	OEMA	77/164	N/A	N/A		
Ridgeline	06-14	AWD	67490/37995	OEMA	96/164	N/A	81295	117	
S2000	00-09	RWD	OEMA 67220(3)/40920	OEMA	90/165	OEMA	OEMA 67220(3)/40929	90/165	
HUMMER									
H1	92-06	4WD	OEMA	OEMA		OEMA	OEMA		
H2	02-09	4WD	N/A	N/A		OEMA/45940 23960/72509	OEMA/45940 23960/72509	167,167 80/169	
<i>45940 for use on OEM style cams only.</i>						86320, 86325 86375	86320, 86325 86375	128,128 129,129	
H3/H3T	06-10	4WD	N/A	N/A		■ OEMA/45940 45938	OEMA/45940 45938	167,167 167,167	
<i>45940 for use on OEM style cams only.</i>						86320, 86325 86370, 86375	86320, 86325 86370, 86375	128,128 129,129	
							86350 (33)/72509	129,169	
HYUNDAI									
Accent	18-20	FWD	N/A	N/A		N/A	81250	117	
Accent	12-17	FWD	N/A	71070(*)	103	N/A	81260	117	
Accent	06-11	FWD	75600(1) 75800(1)	75600(1) 75800(1)	116,116 116,116	N/A	81250	117	
Accent	95-05	FWD	81250	OEMA	117	N/A	81250	117	
Azera	12-17	FWD	OEMA 84090	OEMA 84080	126,125	N/A	81280	117	
Azera from 10/31/2006	07-11	FWD	OEMA 84090	OEMA 84090	126,126	N/A	67195/40920	89/165	
Azera to 10/31/2006	06-06	FWD	OEMA 84090	OEMA 84090	126,126	N/A	67190/40920	89/165	
Elantra Except GT Sport	18-20	FWD	N/A	N/A		N/A	81260	117	
Elantra GT Sport	18-20	FWD	OEMA	OEMA		N/A	81260	117	
Elantra Touring	11-12	FWD	67410	OEMA 67410/85130	92 92/173	N/A	81260	117	
Elantra	11-17	FWD	N/A	N/A		N/A	81260	117	
Elantra	07-10	FWD	67410	OEMA 67410/85130	92 92/173	N/A	81260	117	
Elantra	97-06	FWD	81250	OEMA	117	N/A	81250	117	
Elantra	92-96	FWD	N/A	N/A		N/A	81250	117	
Entourage	07-09	FWD	84120	OEMA	126	N/A	81250	117	
Equus	14-16	RWD	OEMA	OEMA		N/A	N/A		
Equus	11-13	RWD	OEMA	OEMA		N/A	71930	105	

Applications

CAR/MINI-VAN/SUV/TRUCK APPLICATIONS

HYUNDAI-cont.

REAR

FRONT

Model/Body Style	Year	Drive Type	CAMBER/TOOL	TOE/TOOL	Page	Thrust Plate	CASTER/TOOL	CAMBER/TOOL	Page
Excel	90-94	FWD	N/A	N/A			N/A	81250	117
Excel	86-89	FWD	N/A	N/A			OEMA	81250	117
Genesis Sedan	15-16	RWD/AWD	OEMA	OEMA			N/A	N/A	
Genesis Coupe	10-16	RWD	OEMA	OEMA			N/A	81260	117
Genesis Sedan	09-14	RWD	OEMA	OEMA			N/A	71930	105
Ioniq	17-20	FWD	N/A	N/A			N/A	81260	117
Kona	18-20	AWD	N/A	OEMA			N/A	81260	117
Kona	18-20	FWD	N/A	N/A			N/A	81260	117
Nexo	19-20	FWD	OEMA 84090	OEMA 84080	126,125		N/A	81260	117
Palisade	20-20	FWD/AWD	OEMA 84090	OEMA 84085	126,125		N/A	81280	117
Pony	83-87	RWD	N/A	N/A			OEMA	N/A	
Santa Fe	19-20	FWD/AWD	OEMA 84090	OEMA 84085	126,125		N/A	81260	117
Santa Fe	13-18	FWD/AWD	OEMA 84090	OEMA 84085	126,125		N/A	81260	117
Santa Fe	07-12	FWD/AWD	OEMA 84100	OEMA 84100	126,126		N/A	81260	117
Santa Fe	03-06	FWD/AWD	OEMA 67493/ 85130 67495/ 37995, 85130	OEMA 67493/ 85130 67495/ 37995, 85130	96/ 173 96,96 164,173		N/A	81250	117
Santa Fe	01-02	FWD/AWD	OEMA 67493/ 85130	OEMA 67493/ 85130	96/ 173		N/A	81250	117
Scoupe	90-95	FWD	N/A	N/A			N/A	81250	117
Sonata	15-19	FWD	OEMA 84090	OEMA 84085	126,125		N/A	81260	117
Sonata	12-14	FWD	OEMA 84090	OEMA 84080	126,125		N/A	81280	117
Sonata after 5-2011	11-11	FWD	OEMA 84090	OEMA 84080	126,125		N/A	81280	117
Sonata before 5-2011	11-11	FWD	OEMA 84090	OEMA	126		N/A	81260	117
Sonata after 9-21-2006	07-10	FWD	OEMA 84090	OEMA 84090	126,126		N/A	67195/ 40920	89/ 165
Sonata before 9-21-2006	99-06	FWD	N/A	OEMA			N/A	67190/ 40920	89/ 165
Sonata	95-98	FWD	OEMA	OEMA			N/A	81260	117
Sonata	89-94	FWD	N/A	N/A			N/A	81260	117
Stellar	84-88	FWD	N/A	N/A			OEMA	N/A	
Tiburon	03-09	FWD	81250	OEMA	117		N/A	81260	117
Tiburon	97-02	FWD	81250	OEMA	117		OEMA	81250	117
Tucson	16-20	FWD	OEMA 84090	OEMA 84085	126,125		N/A	81260	117
Tucson	10-15	FWD	OEMA 84090	OEMA 84080	126,125		N/A	81260	117
Tucson	10-18	AWD	OEMA 84090	OEMA 84085	126,125		N/A	81260	117
Tucson	05-09	FWD/AWD	81260	OEMA	117		N/A	81260	117
Veloster	19-20	FWD	N/A	N/A			N/A	81260	117
Veloster	12-17	FWD	75600 (1)	75600 (1)	116,116		N/A	81260	117
Veracruz	07-12	FWD/AWD	OEMA 84100	OEMA 84100	126,126		N/A	81260	117
XG300	01-01	FWD	N/A	OEMA			N/A	67190/ 40920	89/ 165
XG350	02-05	FWD	N/A	OEMA			N/A	67190/ 40920	89/ 165

INFINITI

EX35	08-12	RWD/AWD	OEMA	OEMA			73005 72130	73005 72130	114,114 108,108
EX37	13-13	RWD/AWD	OEMA	OEMA			N/A	N/A	

Applications

Alignment Parts

Heavy Duty

OE Replacement

Racing/Builders

Tools

Brake and CV

Gear/Index

CAR/MINI-VAN/SUV/TRUCK APPLICATIONS

INFINITI-cont.			REAR			Thrust Plate	FRONT		
Model/Body Style	Year	Drive Type	CAMBER/TOOL	TOE/TOOL	Page		CASTER/TOOL	CAMBER/TOOL	Page
FX35	09-13	RWD/AWD	OEMA 72265/85130	OEMA 72265/85130	110/173		N/A	N/A	
FX35	03-08	RWD/AWD	OEMA 72265/85130	OEMA 72265/85130	110/173		N/A	81260	117
FX37	13-13	FWD/AWD	OEMA	OEMA			N/A	N/A	
FX45	03-08	RWD/AWD	OEMA 72265/85130	OEMA 72265/85130	110/173		N/A	81260	117
FX50	09-13	RWD/AWD	OEMA	OEMA			N/A	N/A	
G20	97-02	FWD	N/A	N/A			N/A	N/A	
G20	91-96	FWD	81250	OEMA	117		N/A	N/A	
G25	11-12	RWD/AWD	OEMA	OEMA			73005	73005	114,114
			72260/85130	72260/85130	110/173		72130	72130	108,108
			72262/85130	72262/85130	110/173				
G35 Sedan	07-08	RWD/AWD	OEMA	OEMA			73005	73005	114,114
			72260/85130	72260/85130	110/173		72130	72130	108,108
			72262/85130	72262/85130	110/173				
G35 Coupe w/ rear active steer	06-07	RWD/AWD	OEMA	OEMA			73000/8370	73000/8370	114/163
			72260/85130	72260/85130	110/173		72123/8370	72123/8370	108/163
			72262/85130	72262/85130	110/173				
G35 Sedan	03-06	RWD/AWD	OEMA	OEMA			73000/8370	73000/8370	114/163
			72050/85130	72050/85130	106/173		72123/8370	72123/8370	108/163
			72052/85130	72052/85130	106/173				
G35 Coupe w/o rear active steer	03-07	RWD/AWD	OEMA	OEMA			73000/8370	73000/8370	114/163
			72050/85130	72050/85130	106/173		72123/8370	72123/8370	108/163
			72052/85130	72052/85130	106/173				
G37 Convertible	09-13	RWD/AWD	OEMA	OEMA			73005	73005	114,114
			72260/85130	72260/85130	110/173		72130	72130	108,108
			72262/85130	72262/85130	110/173				
G37 Sedan	09-13	RWD/AWD	OEMA	OEMA			73005	73005	114,114
			72260/85130	72260/85130	110/173		72130	72130	108,108
			72262/85130	72262/85130	110/173				
G37 Coupe	08-13	RWD/AWD	OEMA	OEMA			73005	73005	114,114
			72260/85130	72260/85130	110/173		72130	72130	108,108
			72262/85130	72262/85130	110/173				
I30	95-01	FWD	N/A	N/A			N/A	81260	117
I35	02-05	FWD	N/A	N/A			N/A	81260	117
JX35	13-13	FWD/AWD	OEMA	OEMA			N/A	81260	117
J30	92-97	RWD	N/A	OEMA			N/A	N/A	
M30	90-92	RWD	N/A	OEMA			N/A	N/A	
M35	06-10	RWD/AWD	OEMA	OEMA			73005	73005	114,114
			72260/85130	72260/85130	110/173		72130	72130	108,108
			72262/85130	72262/85130	110/173				
M35h 72240, 72250 adjust setback	12-13	RWD/AWD	OEMA	OEMA			N/A	N/A	
			72240	72240	109,109				
			72245(12)	72250	109,109				
			72255		109				
Stock Replacement Part			12020, 12021, 12022		150				
M37 72240, 72250 adjust setback	11-13	RWD/AWD	OEMA	OEMA			N/A	N/A	
			72240	72240	109,109				
			72245(12)	72250	109,109				
			72255		109				
Stock Replacement Part			12020, 12021, 12022		150				

CAR/MINI-VAN/SUV/TRUCK APPLICATIONS

INFINITI-cont.

REAR

FRONT

Model/Body Style	Year	Drive Type	CAMBER/TOOL	TOE/TOOL	Page	Thrust Plate	CASTER/TOOL	CAMBER/TOOL	Page
M45 Sedan w/rear active steer	06-10	RWD/AWD	OEMA 72260/85130 72262/85130 72265/85130	OEMA 72260/85130 72262/85130	110/173 110/173 110/173		73005 72130	73005 72130	114,114 108,108
M45	03-05	RWD/AWD	OEMA	OEMA			N/A	N/A	
M56 72240, 72250 adjust setback	11-13	RWD/AWD	OEMA 72240 72245(12)	OEMA 72240 72250 72255	109,109 109,109 109		N/A	N/A	
Stock Replacement Part			12020, 12021, 12022		150				
Q40	15-15	RWD/AWD	OEMA 72260/85130 72262/85130 72265/85130	OEMA 72260/85130 72262/85130 72265/85130	110/173 110/173 110/173		73005 72130	73005 72130	114,114 108,108
Q45	90-07	RWD	OEMA	OEMA			N/A	N/A	
Q50 Sedan 72240, 72250 adjust setback	14-20	RWD/AWD	OEMA 72240 72245(12)	OEMA 72240 72250 72255	109,109 109,109 109		N/A	N/A	
Stock Replacement Part			12020, 12021, 12022		150				
Q60 72240, 72250 adjust setback	17-20	RWD/AWD	OEMA 72240 72245(12)	OEMA 72240 72250 72255	109,109 109,109 109		N/A	N/A	
Stock Replacement Part			12020, 12021, 12022		150				
Q60 Convertible	14-15	RWD/AWD	OEMA	OEMA			73005 72130	73005 72130	114,114 108,108
Q60 Coupe	14-15	RWD/AWD	OEMA 72265/85130	OEMA 72265/85130	110/173		73005 72130	73005 72130	114,114 108,108
Q70 72240, 72250 adjust setback	14-19	RWD/AWD	OEMA 72240 72245(12)	OEMA 72240 72250 72255	109,109 109,109 109		N/A	N/A	
Stock Replacement Part			12020, 12021, 12022		150				
QX4	97-03	RWD/4WD	N/A	N/A			N/A	81260	117
QX30	17-20	FWD/AWD	N/A	OEMA			N/A	81260	117
QX50	19-20	FWD/AWD	OEMA	OEMA			N/A	N/A	
QX50	14-17	RWD/AWD	OEMA 72265	OEMA 72265	110, 110		73005 72130	73005 72130	114,114 108,108
QX56	04-13	RWD/4WD	OEMA	OEMA			87520	87520	133,133
QX60	14-20	FWD/AWD	OEMA	OEMA			N/A	81260	117
QX70	14-17	RWD/AWD	OEMA 72265	OEMA 72265	110,110		N/A	N/A	
QX80	14-20	RWD/4WD	OEMA	OEMA			87520	87520	133,133

INTERNATIONAL

Pickup	72-75	4WD	N/A	N/A		■	23000(*)/4169	23000(*)/4169	74/163
Pickup (1300)	60-71	4WD	N/A	N/A		■	88940	88940	134,134
Scout	61-71	4WD	N/A	N/A			Axle Wedges	N/A	144
Scout II	73-80	4WD	N/A	N/A		■	23000(*)/4169	23000(*)/4169	74/163

ISUZU

Amigo	90-00	RWD/4WD	N/A	N/A			47700(*)	47700(*)	84,84
Ascender	03-07	AWD	N/A	N/A			OEMA/83785	OEMA/83785	172,172
Axiom	02-04	AWD	N/A	N/A			47700(*)	47700(*)	84,84
Hombre	96-00	RWD	N/A	N/A			47700(*) 97140 95336(22)	47700(*) 97140	84,84 138,138 136
Hombre	96-00	4WD	N/A	N/A			OEMA 83710	OEMA 83710	125

Applications

Alignment Parts

Heavy Duty

OE Replacement

Racing/Builders

Tools

Brake and CV

Gear/Index

CAR/MINI-VAN/SUV/TRUCK APPLICATIONS

ISUZU-cont.			REAR			Thrust Plate	FRONT		
Model/Body Style	Year	Drive Type	CAMBER/TOOL	TOE/TOOL	Page		CASTER/TOOL	CAMBER/TOOL	Page
i-280 45940 for use on OE cams only	06-06	RWD	N/A	N/A		■ OEMA/45940 45938 86320, 86325 86360 86375	OEMA/45940 45938 86320, 86325 86360 86375	167,167 167,167 128,128 129,129 129,129	
i-290 45940 for use on OE cams only	07-08	RWD	N/A	N/A		■ OEMA/45940 45938 86320, 86325 86360 86375	OEMA/45940 45938 86320, 86325 86360 86375	167,167 167,167 128,128 129,129 129,129	
i-350 45940 for use on OE cams only	06-06	4WD	N/A	N/A		■ OEMA/45940 45938 86320, 86325 86360 86375	OEMA/45940 45938 86320, 86325 86360 86375	167,167 167,167 128,128 129,129 129,129	
i-370 45940 for use on OE cams only	07-08	4WD	N/A	N/A		■ OEMA/45940 45938 86320, 86325 86360 86375	OEMA/45940 45938 86320, 86325 86360 86375	167,167 167,167 128,128 129,129 129,129	
I-Mark	85-89	FWD	75200(1)	75200(1)	116,116	N/A	81250	117	
Impulse	90-93	FWD/AWD	81250	OEMA	117	N/A	81250	117	
Impulse	83-89	RWD	N/A	N/A		OEMA	OEMA		
Oasis	96-99	FWD	67155/40920	OEMA	89/165	OEMA	67125/40920 67320(8)/40920	89/165 92/165	
Stock Replacement Part								67075	153
Pickup	81-99	RWD/4WD	N/A	N/A		47700(*)	47700(*)	84,84	
Rodeo Sport	01-03	RWD/4WD	N/A	N/A		47700(*)	47700(*)	84,84	
Rodeo	91-03	RWD/4WD	N/A	N/A		47700(*)	47700(*)	84,84	
Stylus	91-94	FWD	81250	OEMA	117	OEMA	81250	117	
Trooper	81-02	RWD/4WD	N/A	N/A		47700(*)	47700(*)	84,84	
VehiCROSS	00-01	4WD	N/A	N/A		47700(*)	47700(*)	84,84	
JAGUAR									
E-Pace	18-20	AWD	N/A	OEMA		N/A	N/A		
F-Pace	17-20	AWD	N/A	OEMA		OEMA	OEMA		
F-Type	14-20	RWD	N/A	OEMA		OEMA	OEMA		
I-Pace	19-20		N/A	OEMA		N/A	N/A		
S-Type	03-08	RWD	N/A	OEMA		OEMA	OEMA		
Stock Replacement Part			87555		153				
S-Type	00-02	RWD	N/A	OEMA		OEMA 87545	OEMA 87545	134,134	
Stock Replacement Part			87550		153				
X-Type	02-11	FWD/AWD	N/A	OEMA		N/A	N/A		
XE	17-20	RWD/AWD	N/A	OEMA		OEMA	OEMA		
XF	09-20	RWD/AWD	N/A	OEMA		OEMA	OEMA		
XJ	10-20	RWD/AWD	N/A	OEMA		OEMA	OEMA		
XJ	98-09	RWD	N/A	OEMA		N/A	N/A		
XK	07-15	RWD	N/A	OEMA		OEMA	OEMA		
XK8	97-06	RWD	OEMA	OEMA		OEMA	OEMA		
JEEP									
Cherokee (KL)	14-20	RWD/4WD	OEMA	OEMA		N/A	N/A		
Cherokee (XJ)	94-01	RWD	N/A	N/A		■ 23510(*)/ 72509, 23580 47240(*)	23510(*)/ 72509, 23580 26012, 26014	78 169,163 85,83,83	

Applications

Alignment Parts

Heavy Duty

OE Replacement

Racing/Builders

Tools

Brake and CV

Gear/Index

CAR/MINI-VAN/SUV/TRUCK APPLICATIONS

JEEP-cont.			REAR			Thrust Plate	FRONT		
Model/Body Style	Year	Drive Type	CAMBER/TOOL	TOE/TOOL	Page		CASTER/TOOL	CAMBER/TOOL	Page
Cherokee (XJ)	84-93	RWD	N/A	N/A		■ 23510(*) 72509, 23580 47240(*)	23510(*) 72509, 23580	78,78 169,163 85	
Cherokee (XJ)	84-01	4WD	N/A	N/A		■ 23510(*)/ 72509, 23580 47240(*)	23510(*)/ 72509, 23580 26012, 26014	78,78 169,163 85,83,83	
Cherokee (SJ)	74-83	4WD	N/A	N/A		■ 23000(*)/4169	23000(*)/4169	78/163	
Comanche (MJ)	86-92	RWD/4WD	N/A	N/A		■ 23510(*)/ 72509, 23580 47240(*)	23510(*)/ 72509, 23580 26012, 26014	78,78 169,163 85,83,83	
Commander (XK)	06-10	RWD/4WD	N/A	N/A		OEMA	OEMA 23420/37995, 72509 26012, 26014	77/164.169 83,83	
Commando	66-73	4WD	N/A	N/A		23000(*)/4169	23000(*)/4169	74/163	
Compass (MP)	17-20	FWD/AWD	81250	OEMA	117	N/A	81250	117	
Compass (MK)	07-17	FWD/AWD	67455	OEMA	94	N/A	81260	117	
CJ	72-86	4WD	N/A	N/A		■ 23000(*)/4169 80199(*)	23000(*)/4169	74/163 118	
CJ	45-71	4WD	N/A	N/A		■ 23000(*)/ 4169	23000(*)/4169	74/163	
Gladiator (JT)	20-20		N/A	N/A		82375/85130	23400(*)	123/173/76	
Grand Cherokee (WK2)	11-20	RWD/AWD	OEMA	OEMA		OEMA	OEMA 82360	122	
Grand Cherokee (WK)	05-10	RWD/4WD	N/A	N/A		OEMA	OEMA 23420/37995, 72509 26012, 26014	77/164.169 83,83	
Grand Cherokee (WJ)	99-04	RWD/4WD	N/A	N/A		23510(*)/ 72509, 23580 47240(*)	23510(*)/ 72509, 23580 26012, 26014	78,78 169,163 85,83,83	
Grand Cherokee (ZJ)	93-98	RWD/4WD	82370(19)/74910	N/A	122/170	23510(*)/ 72509, 23580 47240(*)	23510(*)/ 72509, 23580 26012, 26014	78,78 169,163 85,83,83	
Grand Wagoneer (SJ)	74-91	4WD	N/A	N/A		23000(*)/4169	23000(*)/4169	74/163	
Jeepster	66-73	4WD	N/A	N/A		■ 23000(*)/ 4169	23000(*)/4169	74/163	
Liberty (KK)	08-13	FWD/AWD	N/A	N/A		OEMA 82365	OEMA 82365	122,122	
Liberty (KJ)	02-07	FWD/AWD	N/A	N/A		OEMA 82365	OEMA 82365 26012, 26014	122,122 83,83	
Patriot (MK)	07-17	FWD/AWD	67455	OEMA	94	N/A	81260	117	
Pickup J10/J20 (SJ)	74-84	4WD	N/A	N/A		■ 23000(*)/4169	23000(*)/4169	74/163	
Renegade (BU)	15-20	FWD/AWD	81250	N/A	177	N/A	81250	117	
Scrambler	82-86	4WD	N/A	N/A		■ 23000(*)/4169	23000(*)/4169	74/163	
Wagoneer (XJ)	84-90	RWD	N/A	N/A		■ 23510(*)/ 72509, 23580 47240(*)	23510(*)/ 72509, 23580	78,78 169,163 85	
Wagoneer (XJ)	84-90	4WD	N/A	N/A		■ 23510(*)/ 72509, 23580 47240(*)	23510(*)/ 72509, 23580 26012, 26014	78,78 169,163 85,83,83	
Wrangler (JL)	18-20	4WD	82376(19)/85130	N/A	123/173	82375/85130	23400(*)	123/173/76	
Replacement Part			13421, 13426		73,73	13411, 13416		73,73	
Wrangler (JK)	07-18	RWD/4WD	82390(19)/74920	N/A	123/170	23510(*)/ 72509, 23580 82390(16) 74910	23510(*)/ 72509, 23580 26012, 26014	78,78 169,163 123/83,83 170	
Replacement Part			13421, 13426		73,73	13410, 13415		73,73	
Wrangler (TJ)	97-06	4WD	82370(19)	N/A	122	23510(*)/ 72509, 23580 82380(16)/	23510(*)/ 72509, 23580 26012, 26014 74910	78,78 169,163 123,83,83 170	
Wrangler (YJ)	87-95	4WD	N/A	N/A		■ Axle Wedges 23510(*)/ 72509, 23580	23510(*)/ 72509, 23580 26012, 26014	144,78 78/169,163 169,163/83	

Applications

Alignment Parts

Heavy Duty

OE Replacement

Racing/Builders

Tools

Brake and CV

Gear/Index

CAR/MINI-VAN/SUV/TRUCK APPLICATIONS

KIA			REAR			Thrust Plate	FRONT		
Model/Body Style	Year	Drive Type	CAMBER/TOOL	TOE/TOOL	Page		CASTER/TOOL	CAMBER/TOOL	Page
Amanti	07-11	FWD	OEMA	OEMA			N/A	67195/40920	89/165
Amanti	04-06	FWD	N/A	OEMA			N/A	67190/40920	89/165
Borrego	08-11	FWD/AWD	OEMA 84100	OEMA 84100	126,126		OEMA	OEMA	
Cadenza	17-20	FWD	OEMA 84090	OEMA 84085	126,126		N/A	81280	117
Cadenza	14-16	FWD	OEMA 84090	OEMA 84085	126,126		N/A	81280	117
Forte	14-20	FWD	N/A	N/A			N/A	81260	117
Forte	09-13	FWD	75600(1)	75600(1)	116,116		N/A	81260	117
K900	16-20	RWD	OEMA 84090	OEMA 84085	126,125		N/A	N/A	
K900	15-15	RWD	OEMA 84090	OEMA 84085	126,125		N/A	71930	105
Niro	17-20	FWD	N/A	OEMA			N/A	81260	117
Optima	16-20	FWD	OEMA 84090	OEMA 84085	126,125		N/A	81280	117
Optima built after 7-1-2011	12-15	FWD	OEMA 84090	OEMA 84080	126,125		N/A	81280	117
Optima built before 7-1-2011	11-12	FWD	OEMA	OEMA 84080	125		N/A	81260	117
Optima	07-10	FWD	67410/85130	OEMA 67410/85130	92/173 92/173		N/A	81260	117
Optima	01-06	FWD	N/A	OEMA			N/A	67190/40920	89/165
Optima Hybrid	17-19	FWD	OEMA 84090	OEMA 84085	126,125		N/A	81280	117
Optima Hybrid	12-16	FWD	OEMA 84090	OEMA 84080	126,125		N/A	81280	117
Rio	18-20	FWD	N/A	N/A			N/A	81250	117
Rio	12-17	FWD	N/A	71070(*)	103		N/A	81260	117
Rio	01-11	FWD	75800(1)	75800(1)	116,116		N/A	81250	117
Rio5	06-11	FWD	75800(1)	75800(1)	116,116		N/A	81250	117
Rondo	07-12	FWD	67410	OEMA 67410/85130	92 92/173		N/A	81260	117
Sedona	15-20	FWD	OEMA 84090	OEMA 84085	126,125		N/A	81280	117
Sedona	06-14	FWD	84120	OEMA	126		N/A	81250	117
Sedona	02-05	FWD	N/A	N/A			N/A	81260	117
Sephia	94-02	FWD	81250	OEMA	117		N/A	OEMA 81250	117
Sorento	16-20	FWD/AWD	OEMA 84090	OEMA 84085	126,126		N/A	81280	117
Sorento	14-15	FWD/AWD	OEMA 84090	OEMA 84085	126,125		N/A	81260	117
Sorento	11-13	FWD/AWD	OEMA 84100	OEMA 84100	126,126		N/A	81260	117
Sorento	03-09	FWD/AWD	N/A	N/A			N/A	OEMA	
Soul	09-19	FWD	75600(1)	75600(1)	116,116		N/A	81260	117
Spectra	01-09	FWD	81250	OEMA	117		N/A	81250	117
Sportage	17-20	FWD	OEMA 84090	OEMA 84085	126,125		N/A	81260	117
Sportage	11-16	FWD	OEMA 84090	OEMA 84080	126,125		N/A	81260	117
Sportage	11-20	AWD	84090	OEMA 84085	126 125		N/A	81260	117

Applications

CAR/MINI-VAN/SUV/TRUCK APPLICATIONS

KIA-cont.

Model/Body Style	Year	Drive Type	REAR			Thrust Plate	FRONT		
			CAMBER/TOOL	TOE/TOOL	Page		CASTER/TOOL	CAMBER/TOOL	Page
Sportage	05-10	FWD/AWD	81260	OEMA	117		N/A	81260	117
Sportage	95-02	FWD/AWD	N/A	N/A			OEMA	OEMA	
Stinger	18-20	RWD/AWD	OEMA 84085	OEMA 84085	125,125		N/A	N/A	
Telluride	20-20	FWD/AWD	OEMA 84090	OEMA 84085	126.125		N/A	81280	117

LAND ROVER

Discovery	17-20	4WD	N/A	OEMA			N/A	N/A	
Discovery	99-04	4WD	N/A	N/A			N/A	N/A	
Discovery Sport	15-20	4WD	N/A	OEMA			N/A	N/A	
Freelander	02-06	4WD	81260	OEMA	117		N/A	81260	117
LR2	05-15	4WD	N/A	OEMA			N/A	N/A	
LR3	05-09	4WD	N/A	OEMA			OEMA	OEMA	
LR4	10-17	4WD	N/A	OEMA			OEMA	OEMA	
Range Rover	13-20	4WD	N/A	OEMA			N/A	N/A	
Range Rover	03-12	4WD	N/A	OEMA			N/A	81280	117
Range Rover	95-02	4WD	N/A	N/A			N/A	N/A	
Range Rover Evoque	12-20	4WD	N/A	OEMA			N/A	N/A	
Range Rover Sport	14-20	4WD	N/A	OEMA			N/A	N/A	
Range Rover Sport	06-13	4WD	OEMA	OEMA			OEMA	OEMA	
Range Rover Velar	18-19	4WD	N/A	OEMA			OEMA	OEMA	

LEXUS

CT	11-17	FWD	67487	OEMA	96		N/A	81290	117
Stock Replacement Part			12030		150				
ES	19-20	FWD	N/A	OEMA			N/A	81290	117
ES	13-18	FWD	81290	N/A	117		N/A	81290	117
ES	92-12	FWD	81270	OEMA	117		N/A	81290 82120/ 85130	117 122/ 173
ES	90-91	FWD	81270	OEMA	117		85690, 85695	81290 82120/ 85130	WB,WB,117 122/ 173
GS	13-19	RWD/AWD	72450	OEMA	112		N/A	N/A	
GS	06-11	RWD/AWD	67520/ 37995	OEMA	97/ 164		N/A	67530/ 40920	97/ 165
GS	98-05	RWD	OEMA 67510/ 85130	OEMA	96/ 173		72270	OEMA 72270	110 110
GS	93-97	RWD	OEMA	OEMA			OEMA 72270	OEMA 72270	110,110
GX	10-20	4WD	N/A	N/A			OEMA 25440/ 40915 25480	OEMA 25440/ 40915 25480	80/ 165 81
Stock Replacement Part			25950		152				
GX	03-09	4WD	N/A	N/A			OEMA, 25435/ 40915 25480	OEMA 25435/ 40915 25480	80/ 165 81
Stock Replacement Part			25950		152				
HS	10-12	FWD	67487	OEMA 67800/ 37995	96 101/ 164		N/A	81290	117
Stock Replacement Part			12030		150				
IS	16-19	RWD/AWD	72450	OEMA	112		N/A	67530/ 40920	97/ 165
IS IS-F	14-14	RWD	67520/ 37995	OEMA	97/ 164		N/A	67530/ 40920	97/ 165
IS Convertible	14-15	RWD/AWD	67520/ 37995	OEMA	97/ 164		N/A	67530/ 40920	97/ 165
IS Except Convertible or IS-F	14-15	RWD/AWD	72450	OEMA	112		N/A	67530/ 40920	97/ 165
IS Inc. IS-F and Convertible	06-13	RWD/AWD	67520/ 37995	OEMA	97/ 164		N/A	67530/ 40920	97/ 165
IS	01-05	RWD	OEMA 67515/ 85130	OEMA	97/ 164		N/A	OEMA 67525/ 40920	97/ 165
LC	18-20	RWD	N/A	OEMA			N/A	N/A	
LS	07-20	RWD/AWD	N/A	OEMA			N/A	N/A	
LS	01-06	RWD	N/A	OEMA			N/A	OEMA	

Applications

Alignment Parts

Heavy Duty

OE Replacement

Racing/Builders

Tools

Brake and CV

Gear/Index

CAR/MINI-VAN/SUV/TRUCK APPLICATIONS

LEXUS-cont.			REAR			Thrust Plate	FRONT		
Model/Body Style	Year	Drive Type	CAMBER/TOOL	TOE/TOOL	Page		CASTER/TOOL	CAMBER/TOOL	Page
LS	90-00	RWD	OEMA	OEMA		OEMA	OEMA		
LX 570	08-20	4WD	N/A	N/A		OEMA 25450/40915 25465	OEMA 25450/40915 25465	80/165 81	
Replacement Part			25965		152				
LX 470	98-07	4WD	N/A	N/A		OEMA 25455	OEMA 25455	80,80	
LX 450	96-98	4WD	N/A	N/A		88915, 88920	88915, 88920	134,134	
NX	15-20	FWD/AWD	67810, 67811	OEMA	102,102	N/A	81290	117	
RC	15-20	RWD/AWD	72450	OEMA	112	N/A	OEMA		
RC-F	18-20	RWD/AWD	N/A	OEMA		N/A	OEMA		
RX	10-19	FWD/AWD	N/A	OEMA		N/A	81290	117	
RX	99-09	FWD/AWD	81270	OEMA	117	N/A	81290 82120/85130	117 122/173	
SC	02-10	RWD	OEMA 67510/85130	OEMA	96/173	72270	OEMA 72270	110 110	
SC	92-01	RWD	OEMA	OEMA		OEMA	OEMA		
UX	19-20	FWD/AWD	N/A	OEMA		N/A	81290	117	
LINCOLN									
Aviator	03-05	RWD/4WD	86180	OEMA	127	86140	86140	127,127	
Blackwood EXT	02-03	RWD/4WD	N/A	N/A		87385	87385	132,132	
Continental	17-20	FWD/AWD	N/A	OEMA		N/A	81280	117	
Continental	95-02	FWD	OEMA	OEMA		OEMA	OEMA		
Continental	88-94	FWD	N/A	OEMA		OEMA	OEMA		
Continental	82-87	RWD	N/A	N/A		N/A	OEMA 81280 82120/85130	117 122/173	
LS	00-06	RWD	N/A	OEMA		OEMA 87545	OEMA 87545	134,134	
Stock Replacement Part			87550		153				
Mark LT	06-08	RWD/4WD	N/A	N/A		OEMA 25680 86250, 86252	OEMA 25680 86250, 86252	82,82 127,127	
Mark VII	84-92	RWD	N/A	N/A		N/A	OEMA 81280 82120/85130	117 122/173	
Mark VIII	93-97	RWD	OEMA	OEMA		OEMA	OEMA 87535	133	
MKC	15-19	FWD/AWD	N/A	OEMA		N/A	N/A		
MKS built after 2/6/12	13-16	FWD/AWD	OEMA 84130	OEMA	126	N/A	N/A		
MKS built before 2/6/12	09-12	FWD/AWD	OEMA 84130	OEMA	126	N/A	OEMA		
MKT	13-19	FWD/AWD	OEMA 84130	OEMA	126	N/A	N/A		
MKT	10-12	FWD/AWD	OEMA 84130	OEMA	126	N/A	OEMA		
MKX	07-18	FWD/AWD	OEMA	OEMA		N/A	81280	117	
MKZ	13-20	AWD	N/A	OEMA		N/A	81280	117	
MKZ	13-20	FWD	67680	OEMA	101	N/A	81280	117	
MKZ	07-12	FWD/AWD	OEMA 67425	OEMA	93	N/A	67115/40920	89/165	
Nautilus	19-20	FWD/AWD	OEMA	OEMA		N/A	81280	117	
Navigator	18-20	RWD/4WD	OEMA	OEMA		OEMA	OEMA		

Applications

Alignment Parts

Heavy Duty

OE Replacement

Racing/Builders

Tools

Brake and CV

Gear/Index

CAR/MINI-VAN/SUV/TRUCK APPLICATIONS

LINCOLN-cont.

REAR

FRONT

Model/Body Style	Year	Drive Type	CAMBER/TOOL	TOE/TOOL	Page	Thrust Plate	CASTER/TOOL	CAMBER/TOOL	Page
Navigator	07-17	RWD/4WD	OEMA 67275 86690	OEMA	90 131		OEMA 25680 86250, 86252	OEMA 25680 86250, 86252	82,82 127,127
Navigator	03-06	RWD/4WD	86680	OEMA	131		86640/ 83820	86640/ 83820	131/ 172
Navigator	98-02	RWD/4WD	N/A	N/A			87385	87385	132,132
Town Car	03-11	RWD	N/A	N/A			OEMA	OEMA 87365/ 02099, 85130	132/ 180,173
Town Car	91-02	RWD	N/A	N/A			OEMA	OEMA/ 88325	174
Town Car	80-90	RWD	N/A	N/A			OEMA	OEMA	
Zephyr	06-06	FWD/AWD	OEMA 67425	OEMA	93		N/A	67115/ 40920	89/ 165

MAZDA

2	11-14	FWD	N/A	N/A			N/A	81250	117
3	19-20	FWD/AWD	N/A	N/A			N/A	N/A	
3	14-18	FWD	67415	OEMA 67415 67417	93 93 93		N/A	81260	117
3 Inc. Mazdaspeed 3	04-13	FWD	67420	OEMA	93		N/A	N/A	
323	90-94	FWD/AWD	81250	OEMA 67070	117 WB		N/A	OEMA 81250	117
323	86-89	FWD/AWD	81250	OEMA	117		N/A	OEMA 81250	117
5	06-15	FWD	67420	OEMA	93		N/A	N/A	
6	14-20	FWD	N/A	OEMA			N/A	81280	117
6	09-13	FWD	67425	OEMA	93		N/A	N/A	
6 Inc. Mazdaspeed 6	03-08	FWD/AWD	OEMA 67425	OEMA	93		N/A	67115/ 40920	89/ 165
626	83-02	FWD	81250	OEMA	117		OEMA	OEMA 81250	117
626	79-82	RWD	N/A	N/A			N/A	N/A	
929	92-95	RWD	OEMA	OEMA			N/A	OEMA	
929	88-91	RWD	N/A	OEMA			OEMA	OEMA 81250	117
B-Series Pickup	98-12	RWD/4WD	N/A	N/A		■	87500	87500	133,133
B-Series Pickup	94-97	RWD/4WD	N/A	N/A		■	23180(*)/ 87175 77880, 88830 24180/ 74400, 74500 87280(24)	23180(*)/ 87175 77880, 88830 24180/ 74400, 74500	75/ 173 171,175 79,79 170,170 131
CX-3	16-20	FWD/AWD	N/A	N/A			N/A	81260	117
CX-5	13-19	FWD/AWD	67416/ 85130	OEMA 67417/ 85130	93/ 173 93/ 173		N/A	81280	117
CX-7	07-12	FWD/AWD	N/A	OEMA			OEMA	OEMA 81260	117
CX-9	16-20	FWD/AWD	N/A	OEMA			N/A	81280	117
CX-9	07-15	FWD/AWD	OEMA	OEMA			N/A	81260	117
GLC	82-85	FWD	81250	OEMA	117		N/A	OEMA 81250	117
GLC	77-83	RWD	N/A	N/A			N/A	N/A	
Millenia	95-02	FWD	OEMA	OEMA			N/A	OEMA	
MPV	89-07	FWD/AWD	N/A	N/A			OEMA	OEMA 81250	117
MX-3	92-95	FWD	81250	OEMA	117		N/A	OEMA 81250	117
MX-5 Miata (ND)	16-20	RWD	OEMA	OEMA			OEMA	OEMA	
MX-5 Miata (NC)	06-15	RWD	OEMA	OEMA			OEMA 83185	OEMA 83185	125,125
MX-5 Miata (NA/NB)	90-05	RWD	OEMA 83180	OEMA 83180	125,125		OEMA 83180	OEMA 83180	125,125
MX-6	88-97	FWD	81250	OEMA	117		OEMA	OEMA 81250	117

Applications

Alignment Parts

Heavy Duty

OE Replacement

Racing/Builders

Tools

Brake and CV

Gear/Index

CAR/MINI-VAN/SUV/TRUCK APPLICATIONS

MAZDA-cont.			REAR			Thrust Plate	FRONT		
Model/Body Style	Year	Drive Type	CAMBER/TOOL	TOE/TOOL	Page		CASTER/TOOL	CAMBER/TOOL	Page
Navajo	91-94	RWD/4WD	N/A	N/A		23180(*)/87175 77880, 88830, 24180/ 74400, 74500 87280(24)	23180(*)/87175 77880, 88830, 24180/ 74400, 74500	75/173 171,175 79,79 170,170 131	
Pickup	86-93	RWD/4WD	N/A	N/A		47700(*)	47700(*)	84,84	
Protege	99-03	FWD/AWD	81250	OEMA	117	OEMA	OEMA 81250	117	
Protege	95-98	FWD/AWD	81250	OEMA 67070	117 WB	OEMA	OEMA 81250	117	
Protege	90-94	FWD/AWD	81250	OEMA	117	OEMA	OEMA 81250	117	
Protege5	02-03	FWD/AWD	81250	OEMA	117	OEMA	OEMA 81250	117	
RX-7	93-96	RWD	OEMA	OEMA		OEMA	OEMA		
RX-7	86-92	RWD	N/A	OEMA		OEMA	OEMA 81250	117	
RX-7	80-85	RWD	N/A	N/A		OEMA	OEMA		
RX-8	04-12	RWD	OEMA	OEMA		OEMA	OEMA		
Tribute	01-11	FWD/AWD	67285/37995	OEMA	91/164	OEMA	OEMA 81250	117	

MERCEDES-BENZ

NOTE: ON ALL MERCEDES - MANUFACTURER RECOMMENDS TOOL #99918 FOR SETTING TOE (PG. 175)

A-Class W177	19-20	FWD/AWD	N/A	N/A		N/A	N/A	
B-Class W246	12-17	FWD	N/A	OEMA		N/A	81260	117
B-Class W245	05-11	FWD	N/A	OEMA		N/A	81260	117
C-Class W205/C205 Sedan & Coupe	16-20	RWD/AWD	28855(32)/ 72509, 76000	OEMA	83 169,171	N/A	N/A	
C-Class W204 Coupe	15-15	RWD	28855(32)/ 72509, 76000	OEMA	83 169,171	28815	28815	83,83
C-Class W204 4MATIC Coupe	15-15	AWD	28855(32)/ 72509, 76000	OEMA	83 169,171	28815	28815 81260	83,83 117
C-Class W205 Sedan	15-16	RWD/AWD	28855(32)/ 72509, 76000	OEMA	83 169,171	N/A	N/A	
C-Class W204	08-14	RWD	28855(32)/ 72509, 76000	OEMA	83 169,171	28815	28815	83,83
C-Class W204 4MATIC	08-14	AWD	28855(32)/ 72509, 76000	OEMA	83 169,171	28815	28815 81260	83,83 117
C-Class W203	01-07	RWD	28840/ 72509, 75990	OEMA	83 169,171	28810	28810	83,83
C-Class W203 4MATIC	01-07	AWD	28840/ 72509, 75990	OEMA	83 169,171	28810	28810 81260	83,83 117
C-Class W202	94-00	RWD/AWD	28840/ 72509, 75990	OEMA	83 169,171	28815	28815	83,83
C-Class W201	82-93	RWD/AWD	N/A	OEMA		OEMA	OEMA	
CL-Class C216	07-14	RWD/AWD	N/A	OEMA		N/A	N/A	
CL-Class C215	00-06	RWD	N/A	OEMA		28815	28815	83,83
CLA-Class C117	14-19	FWD/AWD	N/A	OEMA		N/A	81260	117
CLK-Class W209	04-09	RWD	28840/ 72509, 75990	OEMA	83 169,171	28810	28810	83,83
CLK-Class W208 Cabriolet	03-03	RWD	28840/ 72509, 75990	OEMA	83 169,171	28815	28815	83,83
CLK-Class W209 Coupe	03-03	RWD	28840/ 72509, 75990	OEMA	83 169,171	28810	28810	83,83
CLK-Class W208	98-02	RWD	28840/ 72509, 75990	OEMA	83 169,171	28815	28815	83,83

CAR/MINI-VAN/SUV/TRUCK APPLICATIONS

MERCEDES BENZ-cont. **R E A R** **F R O N T**
 Model/Body Style Year Drive Type CAMBER/TOOL TOE/TOOL Page Thrust Plate CASTER/TOOL CAMBER/TOOL Page

NOTE: ON ALL MERCEDES - MANUFACTURER RECOMMENDS TOOL #99918 FOR SETTING TOE (PG. 175)

CLS-Class W218	12-18	RWD	N/A	OEMA			28815	28815	83,83
CLS-Class W218 4MATIC	12-18	AWD	N/A	OEMA			28815 81260	28815 81260	83,83 117
CLS-Class W219	05-11	RWD	N/A	OEMA			28810	28810	83,83
E-Class C238-Coupe	18-19	RWD/AWD	N/A	OEMA			N/A	N/A	
E-Class W213 Sedan	17-19	RWD/AWD	N/A	OEMA			N/A	N/A	
E-Class W212/S212 Sedan/Wagon	10-16	RWD	28855(32)/ 72509, 76000	OEMA	83 169,171		28815	28815	83,83
E-Class W212/S212 4MATIC Sedan/Wagon	10-16	AWD	28855(32)/ 72509, 76000	OEMA	83 169,171		28815	28815 81260	83,83 117
E-Class A207/C207 Coupe/Convertible	10-17	RWD	28855(32)/ 72509, 76000	OEMA	83 169,171		N/A	N/A	
E-Class A207/C207 4MATIC Coupe/Convertible	10-17	AWD	28855(32)/ 72509, 76000	OEMA	83 169,171		N/A	81260	117
E-Class W211	03-09	RWD	28860(32)/ 72509, 76000	OEMA	83 169,171		28810	28810	83,83
E-Class W211 4MATIC	03-09	AWD	28860(32)/ 72509, 76000	OEMA	83 169,171		28815	28815	83,83
E-Class W210	96-02	RWD/AWD	28840/ 72509, 75990	OEMA	83 169,171		OEMA	OEMA	
E-Class W210-Wagon	96-02	RWD/AWD	N/A	OEMA			OEMA	OEMA	
E-Class W124	86-95	RWD/AWD	28840/ 72509, 75990	OEMA	83 169,171		OEMA	OEMA	
G-Class 463	02-18	4WD	N/A	OEMA			OEMA	OEMA	
GL-Class X166	13-16	AWD	OEMA	OEMA			N/A	N/A	
GL-Class X164	07-12	AWD	OEMA	OEMA			N/A	N/A	
GLA-Class X156	15-20	FWD/AWD	N/A	OEMA			N/A	81260	117
GLC-Class X253/C253	16-19	RWD/AWD	N/A	OEMA			N/A	N/A	
GLE-Class W166/C292	16-18	RWD/AWD	OEMA	OEMA			N/A	N/A	
GLK-Class X204	09-15	RWD/4WD	28850(32)/ 72509, 76000	OEMA	83 169,171		28815	28815 81260	83,83 117
GLS-Class X166	17-19	AWD	OEMA	OEMA			N/A	N/A	
M-Class W166	12-15	AWD	OEMA	OEMA			N/A	N/A	
M-Class W164	06-11	AWD	OEMA	OEMA			N/A	N/A	
M-Class W163	98-05	AWD	N/A	N/A			N/A	N/A	
Metris W447	16-19	RWD	N/A	OEMA			N/A	OEMA 81260	117
R-Class W251	06-12	RWD/AWD	OEMA	OEMA			N/A	OEMA	
S-Class W222	14-19	RWD/AWD	N/A	OEMA			N/A	N/A	
S-Class W221	06-13	RWD/AWD	N/A	OEMA			N/A	N/A	
S-Class W220	99-05	RWD	N/A	OEMA			28810	28810	83,83
S-Class W220 4MATIC	99-05	AWD	N/A	OEMA			28815	28815	83,83
Sprinter Van	07-18	RWD	N/A	N/A		■	N/A	35077	84
Sprinter Van	01-06	RWD	N/A	N/A		■	N/A	35075, 35076	84,84
SL-Class R231	13-19	RWD	N/A	OEMA			28810	N/A	83
SL-Class R230	03-12	RWD	N/A	OEMA			28810	28810	83,83
SL-Class R129	99-02	RWD	28840/ 72509, 75990	OEMA	83 169,171		OEMA	OEMA	
SL-Class R129	89-98	RWD	N/A	OEMA			OEMA	OEMA	
SLC-Class R172	17-19	RWD	N/A	OEMA			N/A	N/A	
SLK R172	12-16	RWD	N/A	OEMA			N/A	N/A	
SLK R171	05-11	RWD	28840/ 72509, 75990	OEMA	83 169,171		28810	28810	83,83
SLK R170	96-04	RWD	28840/ 72509, 75990	OEMA	83 169,171		28815	28815	83,83

Applications

Alignment Parts

Heavy Duty

OE Replacement

Racing/Builders

Tools

Brake and CV

Gear/Index

CAR/MINI-VAN/SUV/TRUCK APPLICATIONS

MECURY			REAR			Thrust Plate	FRONT		
Model/Body Style	Year	Drive Type	CAMBER/TOOL	TOE/TOOL	Page		CASTER/TOOL	CAMBER/TOOL	Page
Capri	91-94	RWD	81250	OEMA	117	OEMA	OEMA 81250	117	
Capri	79-86	RWD	N/A	N/A		N/A	OEMA 81280 82120/ 85130	117 122/ 173	
Comet <i>94009, upper ball joint pg. 157</i>	66-77	RWD	N/A	N/A		OEMA 94210	OEMA 94210 83160	135,135 124	
Comet <i>94009, upper ball joint pg. 157</i>	64-65	RWD	N/A	N/A		47700(*) 94215 94220	47700(*) 94215	84,84 135,135 135	
Comet	60-63	RWD	N/A	N/A		47700(*)	47700(*)	84,84	
Cougar	99-02	FWD	N/A	OEMA		89675	89675	WB, WB	
Cougar	89-97	RWD	OEMA	OEMA		OEMA	OEMA 87535	133	
Cougar	80-88	RWD	N/A	N/A		N/A	OEMA 81280 82120/ 85130	117 122/ 173	
Cougar	74-79	RWD	N/A	N/A		OEMA	OEMA 83160	124	
Cougar <i>94009, upper ball joint pg. 157</i>	67-73	RWD	N/A	N/A		OEMA 94210	OEMA 94210 83160	135,135 124	
Cyclone <i>94009, upper ball joint pg. 157</i>	66-71	RWD	N/A	N/A		OEMA 94210	OEMA 94210 83160	135,135 124	
Cyclone <i>94009, upper ball joint pg. 157</i>	64-65	RWD	N/A	N/A		47700(*) 94215 94220	47700(*) 94215	84,84 135,135 135	
Grand Marquis	03-11	RWD	N/A	N/A		OEMA	OEMA 87365/ 85130,02099	132/ 173,180	
Grand Marquis	91-02	RWD	N/A	N/A		OEMA	OEMA/ 88325	174	
Grand Marquis	83-90	RWD	N/A	N/A		OEMA	OEMA		
Lynx	81-87	FWD	81250	OEMA	117	N/A	N/A		
LN7	82-85	FWD	81250	OEMA	117	N/A	N/A		
Marauder	03-04	RWD	N/A	N/A		OEMA	OEMA 87365/ 85130,02099	132/ 173,180	
Mariner	05-11	FWD/AWD	67285/ 37995	OEMA	91/ 164	OEMA	OEMA 81250	117	
Marquis	83-86	RWD	N/A	N/A		N/A	OEMA 81280 82120/ 85130	117 122/ 173	
Milan	06-11	FWD/AWD	OEMA 67425	OEMA	93	N/A	67115/ 40920	89/ 165	
Monarch	75-80	RWD	N/A	N/A		OEMA	OEMA 83160	124	
Montego	05-07	AWD	67690	OEMA	101	N/A	OEMA		
Stock Replacement Part			12710		151				
Montego	05-07	FWD	71760(*)	OEMA	104	N/A	OEMA		
Montego	66-71	RWD	N/A	N/A		OEMA	OEMA 83160	124	
Monterey	04-07	FWD	N/A	N/A		OEMA/ 68670	OEMA 89685/ 68670	168 135/ 168	
Mountaineer	06-10	RWD/4WD	OEMA	OEMA		OEMA	OEMA		
Mountaineer	02-05	RWD/4WD	86180	OEMA	127	86140	86140	127,127	
Mountaineer	96-01	RWD/4WD	N/A	N/A		87310 87500	87310 87500	131,131 133,133	

Applications

CAR/MINI-VAN/SUV/TRUCK APPLICATIONS

MERCURY-cont.

REAR

FRONT

Model/Body Style	Year	Drive Type	CAMBER/TOOL	TOE/TOOL	Page	Thrust Plate	CASTER/TOOL	CAMBER/TOOL	Page
Mystique	95-00	FWD	N/A	OEMA			89675	89675	WB,WB
Sable	08-09	AWD	67690	OEMA	101		N/A	OEMA	
Stock Replacement Part			12710		151				
Sable	08-09	FWD	71760(*)	OEMA	104		N/A	OEMA	
Sable Wagon	96-05	FWD	87350/ 85130	OEMA/ 97650	132/ 173 175		OEMA/ 68670	OEMA 89635/ 68670	168 134/ 168
Sable Sedan	86-06	FWD	87330/ 87320	OEMA/ 87325	132/ 174		OEMA/ 68670	OEMA	168
<i>87325 Intended for use on OE product NOT intended for aftermarket parts.</i>			8370	87330/ 8370, 87320	173/132 163,132			OEMA 89635 (96-07 Only)	134
Sable Wagon	86-95	FWD	87350/ 85130	OEMA/ 97650	132/ 173 175		OEMA/ 68670	OEMA/ 68670	168,168
Topaz	86-94	FWD/AWD	81250	OEMA/ 87325	117/ 174		N/A	N/A	
Topaz	84-85	FWD/AWD	81250	N/A	117		N/A	N/A	
Tracer	97-99	FWD	81250	N/A	117		N/A	OEMA 81250	117
Tracer	95-96	FWD	81250	OEMA	117		OEMA	OEMA 81250	117
Tracer	91-94	FWD	81250	OEMA 67070	117 WB		OEMA	OEMA 81250	117
Tracer	87-90	FWD	81250	OEMA	117		N/A	OEMA 81250	117
Villager	93-02	FWD	75400 (1)	75400 (1)	116,116		N/A	81250	117
Zephyr	78-83	RWD	N/A	N/A			N/A	OEMA 81280 82120/ 85130	117 122/ 173

MINI

Cooper Convertible F57	16-20	FWD	OEMA 67108	OEMA/ 87566	174 88		N/A	N/A	
Cooper Hardtop F55/F56	14-20	FWD	OEMA 67108	OEMA/ 87566	174 88		N/A	N/A	
Cooper Convertible R57	09-15	FWD	OEMA/ 87560 67610	OEMA/ 87566	174,174 99		67630/ 72095	67630/ 72095	99/ 169
Cooper Hardtop R55/R56	07-13	FWD	OEMA/ 87560 67610	OEMA/ 87566	174,174 99		67630/ 72095	67630/ 72095	99/ 169
Cooper JCW GP	07-13	FWD	OEMA/ 87560 67610	OEMA/ 87566	174,174 99		N/A	N/A	
Cooper Convertible R52	04-08	FWD	OEMA/ 87560 67610	OEMA/ 87566	174,174 99		67620/ 72095	67620/ 72095	99/ 169
Cooper Hardtop R50/R53 before 3/02	02-02	FWD	OEMA/ 87560 67610	OEMA/ 87566	174,174 99		N/A	N/A	
Cooper Hardtop R50/R53 after 3/02	02-06	FWD	OEMA/ 87560 67610	OEMA/ 87566	174,174 99		67620/ 72095	67620/ 72095	99/ 169
Cooper Clubman F54	16-20	FWD	OEMA 67108	OEMA/ 87566	174 88		N/A	N/A	
Cooper Clubman R55	08-14	FWD	OEMA/ 87560 67610	OEMA/ 87566	174,174 99		67630/ 72095	67630/ 72095	99/ 169
Cooper Countryman F60	17-20	FWD/AWD	OEMA 67108	OEMA/ 87566	174 88		N/A	N/A	
Cooper Countryman R60	11-16	FWD/AWD	OEMA/ 87560 67610	OEMA/ 87566	174,174 99		67630/ 72095	67630/ 72095	99/ 169
Cooper Paceman R61	13-16	FWD/AWD	OEMA/ 87560 67610	OEMA/ 87566	174,174 99		67630/ 72095	67630/ 72095	99/ 169
Coupe Inc. Roadster R58/R59	12-15	FWD	OEMA/ 87560 67610	OEMA/ 87566	174,174 99		67630/ 72095	67630/ 72095	99/ 169

MITSUBISHI

3000GT	90-99	FWD/AWD	OEMA	OEMA			N/A	OEMA 81250	117
Diamante	97-04	FWD	73400+73415 (7) 73600, 73620(8)	OEMA	115,115 115,115		N/A	81250	117
Diamante	92-96	FWD/AWD	OEMA	OEMA			N/A	81250	117

Applications

Alignment Parts

Heavy Duty

OE Replacement

Racing/Builders

Tools

Brake and CV

Gear/Index

CAR/MINI-VAN/SUV/TRUCK APPLICATIONS

MITSUBISHI-cont.			R E A R			Thrust Plate	F R O N T		
Model/Body Style	Year	Drive Type	CAMBER/TOOL	TOE/TOOL	Page		CASTER/TOOL	CAMBER/TOOL	Page
Eclipse	06-12	FWD	OEMA	OEMA		N/A	81280	117	
Eclipse <i>73400 must be used with 73415</i>	00-05	FWD	73400+73415(7) 73600, 73620(8)	OEMA	115,115 115,115	N/A	81280 82120/85130	117 122/173	
Eclipse <i>73400 must be used with 73415</i>	95-99	FWD/AWD	73400,+73415(7) 73600, 73620(8)	OEMA	115,115 115,115	N/A	67170/40920 67370(8)/40920	89/165 92/165	
Eclipse	90-94	AWD	OEMA	OEMA		N/A	81250	117	
Eclipse	90-94	FWD	N/A	N/A		N/A	81250	117	
Eclipse Cross	18-20	FWD/AWD	N/A	OEMA		N/A	81260	117	
Endeavor	04-11	FWD/AWD	OEMA	OEMA		N/A	81280	117	
Expo	92-95	FWD/AWD	N/A	OEMA		N/A	81250	117	
Expo LRV	92-94	FWD/AWD	N/A	OEMA		N/A	81250	117	
Galant	04-12	FWD	OEMA	OEMA		N/A	81280	117	
Galant <i>73400 must be used with 73415</i>	99-03	FWD/AWD	73400+73415(7) 73600, 73620(8)	OEMA	115,115 115,115	N/A	81280 82120/85130	117 122/173	
Galant <i>73400 must be used with 73415</i>	94-98	FWD/AWD	73400+73415(7) 73600, 73620(8)	OEMA	115,115 115,115	N/A	67170/40920 67370(8)/40920	89/165 92/165	
Galant	85-93	FWD	N/A	N/A		N/A	81250	117	
i-MiEV	12-17	RWD	N/A	N/A		N/A	N/A		
Lancer	08-17	FWD/AWD	67455	OEMA	94	N/A	81260	117	
Lancer	02-07	FWD/AWD	N/A	OEMA		N/A	81260	117	
Lancer Evolution	02-15	AWD	OEMA	OEMA		N/A	81260	117	
Mighty Max Pickup	86-98	RWD/4WD	N/A	N/A		47700(*)	47700(*)	84,84	
Mirage Inc. G4	17-20	FWD	N/A	N/A		N/A	81250	117	
Mirage	14-15	FWD	N/A	N/A		N/A	81250	117	
Mirage	94-03	FWD	OEMA	OEMA		N/A	81250	117	
Mirage	85-93	FWD/AWD	N/A	N/A		N/A	81250	117	
Montero	01-06	FWD/AWD	OEMA	OEMA		47700(*)	47700(*)	84,84	
Montero Sport	97-04	RWD/4WD	N/A	N/A		OEMA	OEMA		
Outlander	07-20	FWD/AWD	67455	OEMA	94	N/A	81260	117	
Outlander	03-06	FWD/AWD	N/A	OEMA		N/A	81260	117	
Outlander Sport	11-19	FWD/AWD	67455	OEMA	94	N/A	81260	117	
Precis	87-93	FWD	N/A	N/A		OEMA	81250	117	
Raider	06-09	RWD/4WD	N/A	N/A		OEMA 82400	OEMA 82400	124,124	
RVR	10-15	FWD/AWD	67455	OEMA	94	N/A	81260	117	
Starion	83-89	RWD	N/A	OEMA		OEMA	N/A		
Tredia	83-88	FWD/AWD	N/A	N/A		OEMA	81250	117	
Van	87-91	FWD	N/A	N/A		N/A	OEMA		

NAVISTAR

See our Heavy Duty Section pages 141-149

NISSAN

200SX (B14)	94-98	FWD	N/A	N/A		N/A	81250	117
200SX (S12)	84-88	RWD	N/A	OEMA		N/A	83115/73010(4)	124/170
200SX (S110)	80-83	RWD	N/A	N/A		N/A	N/A	
210	79-82	RWD	N/A	N/A		N/A	N/A	
240SX (S14)	95-98	RWD	OEMA 67775, 67776	OEMA 67740	101,101,101	67720	OEMA 81250	101 117
240SX (S13)	89-94	RWD	OEMA 67765	OEMA 67740	101	67720	OEMA 81250	101 117
240Z	71-73	RWD	N/A	N/A		N/A	83115/73010(4)	124/170
260Z	74-74	RWD	N/A	N/A		N/A	83115/73010(4)	124/170
280Z	75-78	RWD	N/A	N/A		N/A	83115/73010(4)	124/170

CAR/MINI-VAN/SUV/TRUCK APPLICATIONS

NISSAN-cont.

REAR			FRONT						
Model/Body Style	Year	Drive Type	CAMBER/TOOL	TOE/TOOL	Page	Thrust Plate	CASTER/TOOL	CAMBER/TOOL	Page
280ZX	79-83	RWD	N/A	N/A			N/A	83115/ 73010(4)	124/ 170
300ZX	90-96	RWD	OEMA 67765	OEMA	101		N/A	83115/ 73010(4)	124/ 170
300ZX	84-89	RWD	N/A	OEMA			N/A	83115/ 73010(4)	124/ 170
310	79-82	RWD	N/A	N/A			N/A	N/A	
350Z	03-08	RWD	OEMA 72050/85130 72052/ 85130 72055/ 85130	OEMA 72050/85130 72052/ 85130 72055/ 85130	106/ 173 106/ 173 106/ 173		73000/ 8370 72123/ 8370	73000/ 8370 72123/ 8370	114/ 163 108/ 163
370Z	09-20	RWD	OEMA 72260/85130 72262/ 85130 72265/ 85130	OEMA 72260/85130 72262/ 85130	110/ 173 110/ 173 110/ 173		73005 72130	73005 72130	114,114 108,108
510	78-81	RWD	N/A	N/A			N/A	N/A	
810	77-83	RWD	N/A	N/A			N/A	83115/ 73010(4)	124/ 170
Altima	19-20	FWD/AWD	N/A	OEMA			N/A	N/A	
Altima Sedan	13-18	FWD	OEMA 72295	OEMA	111		N/A	81260	117
Altima Sedan	07-12	FWD	OEMA 72055/ 85130 72290/85130	OEMA 72055/ 85130 72290/85130	106/ 173		N/A	81260	117
Altima Coupe	07-13	FWD	OEMA 72055/ 85130 72290/85130	OEMA 72055/ 85130 72290/85130	106/ 173		N/A	81260	117
Altima	02-06	FWD	OEMA 72050/85130 72052/ 85130 72055/ 85130	OEMA 72050/85130 72052/ 85130 72055/ 85130	106/ 173 106/ 173 106/ 173		N/A	81260	117
Altima	93-01	FWD	81250	OEMA	117		N/A	81250	117
Armada	17-20	RWD/4WD	OEMA	OEMA			OEMA 87520	OEMA 87520	133,133
Armada	04-15	RWD/4WD	OEMA	OEMA			25560 87520	25560 87520	82,82 133,133
Axxess	90-95	FWD/AWD	N/A	OEMA			N/A	81250	117
B110	70-73	RWD	N/A	N/A			N/A	N/A	
B210	73-78	RWD	N/A	N/A			N/A	N/A	
Cube	09-14	FWD	75610(1)	75610(1)	116,116		N/A	81260	117
<i>NOTE: Vehicles with rear disc brakes may also need pn, 75970</i>									
Frontier	05-19	RWD/4WD	N/A	N/A		■	25540 87520	25540 87520	82,82 133,133
Stock Replacement Part									
Frontier	98-04	RWD/4WD	N/A	N/A		■	OEMA 87515	OEMA 87515	133,133
GT-R	09-20	AWD	OEMA	OEMA			OEMA	OEMA	
Juke	11-17	AWD	OEMA	OEMA			N/A	81260	117
Juke	11-17	FWD	71000(*)	71000(*)	102,102		N/A	81260	117
Kicks	18-20	FWD	N/A	N/A			N/A	81260	117
Leaf	18-20	FWD	N/A	N/A			N/A	81260	117
Leaf	11-17	FWD	71000(*)	71000(*)	102,102		N/A	81260	117
Maxima	16-20	FWD	OEMA 72295	OEMA	111		N/A	81260	117
Maxima	04-14	FWD	72050/85130 72052/ 85130 72055/ 85130	72050/85130 72052/ 85130 72055/ 85130	106/ 173 106/ 173 106/ 173		N/A	81260	117
Maxima	95-03	FWD	N/A	N/A			N/A	81260	117
Maxima	85-94	FWD	67010	OEMA	WB		N/A	81250	117
Maxima	82-84	RWD	N/A	N/A			N/A	83115/ 73010(4)	124/ 170
Murano Inc. CrossCabriolet	03-20	FWD/AWD	OEMA	OEMA			N/A	81260	117

Applications

Alignment Parts

Heavy Duty

OE Replacement

Racing/Builders

Tools

Brake and CV

Gear/Index

CAR/MINI-VAN/SUV/TRUCK APPLICATIONS

NISSAN-cont.			REAR			Thrust Plate	FRONT		Page
Model/Body Style	Year	Drive Type	CAMBER/TOOL	TOE/TOOL	Page		CASTER/TOOL	CAMBER/TOOL	
NV 1500/2500/3500/ Passenger Van	12-20	RWD	N/A	N/A		OEMA 87520	OEMA 87520	133,133	
NV200	13-20	FWD	N/A	N/A		N/A	81260	117	
NX	91-94	FWD	81250	OEMA	117	N/A	81250	117	
Pathfinder	13-20	FWD/AWD	OEMA	OEMA		N/A	81260	117	
Pathfinder	05-12	RWD/4WD	OEMA	OEMA		25540 87520	25540 87520	82,82 133,133	
Stock Replacement Part							21035	152	
Pathfinder	96-04	RWD/4WD	N/A	N/A		N/A	81260	117	
Pathfinder	87-95	RWD/4WD	N/A	N/A		35080(*)	35080(*)	84,84	
Pickup	86-97	RWD/4WD	N/A	N/A		■ 35080(*)	35080(*)	84,84	
Pulsar	87-90	FWD	81250	OEMA	117	N/A	OEMA 81250	117	
Pulsar	83-86	FWD	N/A	N/A		N/A	81250	117	
Quest	04-17	FWD	OEMA	OEMA		N/A	81260	117	
Quest	93-02	FWD	75400(1)	75400(1)	116,116	N/A	81250	117	
Rogue	14-20	FWD/AWD	OEMA	OEMA		N/A	81260	117	
Rogue	08-13	FWD/AWD	N/A	OEMA		N/A	81260	117	
Rogue Select	14-15	FWD/AWD	N/A	OEMA		N/A	81260	117	
Rogue Sport	17-19	FWD/AWD	OEMA	OEMA		N/A	81260	117	
Sentra <i>NOTE: Vehicles with rear disc brakes may also need pn, 75970</i>	13-19	FWD	75610(1)	75610(1)	116,116	N/A	81260	117	
Sentra	07-12	FWD	71700(*)	71700(*)	104,104	N/A	81260	117	
Sentra	95-06	FWD	N/A	N/A		N/A	81250	117	
Sentra Wagon	87-90	4WD	81250	OEMA	117	N/A	OEMA 81250	117	
Sentra	87-94	FWD	81250	OEMA	117	N/A	OEMA 81250	117	
Sentra	83-86	FWD	N/A	N/A		N/A	81250	117	
Stanza	87-92	FWD	67010	OEMA	WB	N/A	81250	117	
Stanza Wagon	85-88	FWD	N/A	N/A		N/A	81250	117	
Stanza Wagon	85-88	4WD	81260	OEMA	117	N/A	81250	117	
Stanza	82-86	FWD	N/A	OEMA		N/A	81250	117	
Titan XD only	16-19	RWD/4WD	N/A	N/A		■ OEMA	OEMA		
Titan Except XD	16-20	RWD/4WD	N/A	N/A		■ OEMA 25560 87520	OEMA 25560 87520	82,82 133,133	
Titan	04-15	RWD/4WD	N/A	N/A		■ 25560 87520	25560 87520	82,82 133,133	
Stock Replacement Part							21035	152	
Versa Inc. Note	12-19	FWD	71860(*) 75200(1)	75200(1)	105,116 116	N/A	81260	117	
Versa <i>NOTE: Vehicles with rear disc brakes may also need pn, 75970</i>	07-11	FWD	75610(1)	75610(1)	116,116	N/A	81260	117	
Xterra	05-15	RWD/4WD	N/A	N/A		■ 25540 87520	25540 87520	82,82 133,133	
Stock Replacement Part							21035	152	
Xterra	00-04	RWD/4WD	N/A	N/A		OEMA 87515	OEMA	133	

CAR/MINI-VAN/SUV/TRUCK APPLICATIONS

OLDSMOBILE			REAR			Thrust Plate	FRONT		
Model/Body Style	Year	Drive Type	CAMBER/TOOL	TOE/TOOL	Page		CASTER/TOOL	CAMBER/TOOL	Page
442 <i>94391, Pro Springs (64-67) pg. 137</i> <i>94392, Pro Springs (68-72) pg. 137</i> <i>94001, upper ball joint pg. 157</i>	64-72	RWD	N/A	N/A		47700(*) 97110 94344(22)	47700(*) 97110	84,84 138,138 136	
88	86-99	FWD	81280 82120/ 85130	OEMA	117 122/ 173	OEMA/ 85130	81280 82120/ 85130	173 /117 122/ 173	
88 <i>94006, upper ball joint pg. 157</i> <i>94017, 1/2" ext upper ball joint pg. 157</i> <i>94011, lower ball joint pg. 157</i>	71-85	RWD	N/A	N/A		47700(*) 97130 94378(22)	47700(*) 97130	84,84 138,138 136	
98	85-99	FWD	81280 82120/ 85130	OEMA	117 122/ 173	OEMA	81280 82120/ 85130	117 122/ 173	
98	77-84	RWD	N/A	N/A		47700(*)	47700(*)	84,84	
Achieva	96-98	FWD	75400(1)	75400(1)	116,116	N/A	81260	117	
Achieva	92-95	FWD	75400(1)	75400(1)	116,116	N/A	81280 82120/ 85130	117 122/ 173	
Alero	99-04	FWD	81250	OEMA	117	N/A	81260	117	
Aurora	95-03	FWD	75600(1) 75800(1)	OEMA 75600(1) 75800(1)	116 116,116 116	OEMA	81280 / 85130 82120/ 85130	117/ 173 122/ 173	
Bravada	02-04	RWD/4WD	N/A	N/A		OEMA/ 83785	OEMA/ 83785	172,172	
Bravada	91-01	4WD	N/A	N/A		OEMA 83710	OEMA 83710	125,125	
Custom Cruiser	80-92	RWD	N/A	N/A		47700(*)	47700(*)	84,84	
Cutlass	97-99	FWD	81250	OEMA	117	N/A	81260	117	
Cutlass Inc. Supreme <i>94390, Pro Springs pg. 137</i> <i>94006, upper ball joint pg. 157</i> <i>94011, lower ball joint pg. 157</i>	78-88	RWD	N/A	N/A		47700(*) 97140 95336(22)	47700(*) 97140	84,84 138,138 136	
Cutlass Inc. Supreme <i>94006, upper ball joint pg. 157</i> <i>94017, 1/2" ext upper ball joint pg. 157</i> <i>94011, lower ball joint pg. 157</i>	73-77	RWD	N/A	N/A		47700(*) 97130 94378(22)	47700(*) 97130	84,84 138,138 136	
Cutlass Inc. Supreme <i>94391, Pro Springs (64-67) pg. 137</i> <i>94392, Pro Springs (68-72) pg. 137</i> <i>94001, upper ball joint pg. 157</i>	64-72	RWD	N/A	N/A		47700(*) 97110 94344(22)	47700(*) 97110	84,84 138,138 136	
Cutlass Calais	85-91	FWD	75400(1)	75400(1)	116,116	N/A	81280 82120/ 85130	117 122/ 173	
Cutlass Ciera Inc. Cruiser	82-96	FWD	75600(1) 75800(1)	75600(1) 75800(1)	116,116 116,116	N/A	82110/ 85130	121/ 173	
Cutlass Supreme	88-97	FWD	81280 82120/ 85130	OEMA/ 83850	117/ 173 122/ 173	N/A	N/A		
Firenza	82-89	FWD	75400(1)	75400(1)	116,116	N/A	81280 82120/ 85130	117 122/ 173	
Intrigue	97-02	FWD	81260	OEMA/ 83850	117/173	N/A	81260	117	
LSS	98-99	FWD	81280 82120/ 85130	OEMA	117 122/ 173	OEMA	81280 82120/ 85130	117 122/ 173	
Omega	80-84	FWD	75400(1)	75400(1)	116,116	N/A	82110/ 85130	121/ 173	
Omega <i>94006, upper ball joint pg. 157</i> <i>94017, 1/2" ext upper ball joint pg. 157</i> <i>94011, lower ball joint pg. 157</i>	75-79	RWD	N/A	N/A		47700(*) 97130 94378(22)	47700(*) 97130	84,84 138,138 136	
Regency	97-99	FWD	81280 82120/ 85130	OEMA	117 122/ 173	OEMA	81280 82120/ 85130	117 122/ 173	
Silhouette	02-04	AWD	OEMA	OEMA		N/A	81260	117	
Silhouette	97-04	FWD	75600(1) 75800(1)	75600(1) 75800(1)	116,116 116,116	N/A	81260	117	
Silhouette	90-96	FWD	75600(1) 75800(1)	75600(1) 75800(1)	116,116 116,116	N/A	82110/ 85130	121/ 173	

Applications

Alignment Parts

Heavy Duty

OE Replacement

Racing/Builders

Tools

Brake and CV

Gear/Index

CAR/MINI-VAN/SUV/TRUCK APPLICATIONS

OLDSMOBILE-cont.			REAR			Thrust Plate	FRONT		
Model/Body Style	Year	Drive Type	CAMBER/TOOL	TOE/TOOL	Page		CASTER/TOOL	CAMBER/TOOL	Page
Toronado	86-92	FWD	75600(1) 75800(1)	OEMA/83775 75600(1) 75800(1)	116/172 116,116 116	OEMA	OEMA 81280 82120/85130	117 122/173	
Toronado	78-85	FWD	75600(1) 75800(1)	OEMA/83775 75600(1) 75800(1)	116/172 116,116 116	OEMA	OEMA		
PETERBILT									
See our Heavy Duty Section			pages 141-149						
PLYMOUTH									
Acclaim	89-94	FWD	75200(1)	75200(1)	116,116	N/A	OEMA 83170/85130	125/173	
All Passenger B & E Bodies <i>94009, upper ball joint pg. 157</i>	62-64	RWD	N/A	N/A		OEMA 97300	OEMA 97300	140,140	
All Passenger Car Models Except B & E	60-73	RWD	N/A	N/A		OEMA 83160	OEMA 83160	124,124	
Barracuda <i>94009, upper ball joint pg. 157</i>	70-74	RWD	N/A	N/A		OEMA 97300	OEMA 97300	140,140	
Belvedere <i>94009, upper ball joint pg. 157</i>	65-70	RWD	N/A	N/A		OEMA 97300	OEMA 97300	140,140	
Breeze	96-00	FWD	OEMA	OEMA		N/A	67180/40920	89/165	
Caravelle	84-88	FWD	75200(1)	75200(1)	116,116	N/A	OEMA 83170/85130	125/173	
Colt Vista	92-94	FWD	N/A	OEMA		N/A	81250	117	
Colt Vista	85-94	4WD	N/A	OEMA		OEMA	81250	117	
Colt Vista	84-91	FWD	N/A	N/A		N/A	81250	117	
Conquest	84-86	RWD	N/A	N/A		N/A	N/A		
Duster <i>94009, upper ball joint pg. 157</i>	73-76	RWD	N/A	N/A		OEMA 97300	OEMA 97300	140,140	
Gran Fury	65-89	RWD	N/A	N/A		OEMA	OEMA		
GTX <i>94009, upper ball joint pg. 157</i>	67-71	RWD	N/A	N/A		OEMA 97300	OEMA 97300	140,140	
Horizon	78-90	FWD	75200(1)	75200(1)	116,116	N/A	OEMA 83170/85130	125/173	
Laser	92-94	AWD	OEMA	OEMA		N/A	81250	117	
Laser	89-94	FWD	N/A	N/A		N/A	81250	117	
Neon	94-01	FWD	67210 81250	OEMA 67210	90 117,90	N/A	81260	117	
Prowler	97-02	RWD	N/A	N/A		OEMA	OEMA		
Reliant	81-89	FWD	75200(1)	75200(1)	116,116	N/A	OEMA 83170/85130	125/173	
Roadrunner <i>94009, upper ball joint pg. 157</i>	68-72	RWD	N/A	N/A		OEMA 97300	OEMA 97300	140,140	
Sapporo	80-83	RWD	N/A	N/A		N/A	N/A		
Satellite <i>94009, upper ball joint pg. 157</i>	65-72	RWD	N/A	N/A		OEMA 97300	OEMA 97300	140,140	
Scamp	82-85	FWD	75200(1)	75200(1)	116,116	N/A	OEMA 83170/85130	125/173	
Sundance	87-94	FWD	75200(1)	75200(1)	116,116	N/A	OEMA 83170/85130	125/173	
Trailduster	74-81	RWD	N/A	N/A		OEMA 83160	OEMA 83160	124,124	
Trailduster	74-81	4WD	N/A	N/A		23000(*)/4169	23000(*)/4169	74/163	
Turismo	79-87	FWD	75200(1)	75200(1)	116,116	N/A	OEMA 83170/85130	125/173	

Applications

CAR/MINI-VAN/SUV/TRUCK APPLICATIONS

Applications

Alignment Parts

Heavy Duty

OE Replacement

Racing/Builders

Tools

Brake and CV

Gear/Index

PLYMOUTH-cont.

Model/Body Style *Year* *Drive Type*

REAR

CAMBER/TOOL *TOE/TOOL* *Page*

FRONT

Thrust Plate *CASTER/TOOL* *CAMBER/TOOL* *Page*

Valiant <i>94009, upper ball joint pg. 157</i>	73-76	RWD	N/A	N/A		OEMA 97300	OEMA 97300	140,140
Voyager	96-01	AWD	N/A	N/A		N/A	OEMA 83170/ 85130	125/ 173
Voyager	96-01	FWD	71700(*)	71700(*)	104,104	N/A	OEMA 81260 83170/ 85130	117 125/ 173
Voyager	90-95	AWD	N/A	N/A		N/A	OEMA 83170/ 85130	125/ 173
Voyager	84-95	FWD	75400 (1)	75400 (1)	116,116	N/A	OEMA 83170/ 85130	125/ 173

PONTIAC

6000	82-91	FWD	75600 (1) 75800 (1)	75600 (1) 75800 (1)	116,116 116,116	N/A	82110/ 85130	121/ 173
Aztek	01-06	AWD	OEMA	OEMA		N/A	81260	117
Aztek	01-06	FWD	75600 (1) 75800 (1)	75600 (1) 75800 (1)	116,116 116,116	N/A	81260	117
Bonneville	00-05	FWD	75600 (1) 75800 (1)	OEMA 75600 (1) 75800 (1)	116 116,116 116	N/A	81280 82120/ 85130	117 122/ 173
Bonneville	87-99	FWD	81280 82120/ 85130	OEMA	117 122/ 173	OEMA/ 85130	81280 82120/ 85130	173 /117 122/ 173
Bonneville <i>94390, Pro Springs pg. 137</i> <i>94006, upper ball joint pg. 157</i> <i>94011, lower ball joint pg. 157</i>	82-86	RWD	N/A	N/A		47700(*) 97140 95336 (22)	47700(*) 97140	84,84 138,138 136
Bonneville <i>94011, lower ball joint pg. 157</i>	77-81	RWD	N/A	N/A		47700(*) 94378 (22)	47700(*)	84,84 136
Bonneville <i>94006, upper ball joint pg. 157</i> <i>94017, 1/2" ext upper ball joint pg. 157</i> <i>94011, lower ball joint pg. 157</i>	71-76	RWD	N/A	N/A		47700(*) 97130 94378 (22)	47700(*) 97130	84,84 138,138 136
Catalina	65-81	RWD	N/A	N/A		47700(*)	47700(*)	84,84
Fiero	84-88	RWD	82110/ 85130	OEMA	121/ 173	OEMA	OEMA	
Firebird	93-02	RWD	N/A	N/A		OEMA/ 83775	OEMA/ 83775	172,172
Firebird	82-92	RWD	N/A	N/A		OEMA	OEMA 81280 82120/ 85130	117 122/ 173
Firebird <i>94006, upper ball joint pg. 157</i> <i>94017, 1/2" ext upper ball joint pg. 157</i> <i>94011, lower ball joint pg. 157</i>	70-81	RWD	N/A	N/A		47700(*) 97130 94378 (22)	47700(*) 97130	84,84 138,138 136
Firebird <i>94393, Pro Springs pg. 137</i> <i>94001, upper ball joint pg. 157</i>	67-69	RWD	N/A	N/A		47700(*) 97120 94374 (22)	47700(*) 97120	84,84 138,138 136
Firefly	85-91	FWD	N/A	N/A		N/A	81250	117
G3 Wave	05-10	FWD	75200 (15)	75200 (15)	116,116	N/A	81250	117
G5	07-09	FWD	75400 (1)	75400 (1)	116,116	N/A	81250	117
G6	05-10	FWD	OEMA 75400 (17) 82100	OEMA 75400 (17) 82100	116,116 121,121	N/A	81250	117
G8	08-09	RWD	OEMA 87430	OEMA 87430	133,133	OEMA	81260	117
Grand Am	99-05	FWD	81250	OEMA	117	N/A	81260	117
Grand Am	96-98	FWD	75400 (1)	75400 (1)	116,116	N/A	81260	117
Grand Am	88-95	FWD	75400 (1)	75400 (1)	116,116	N/A	81280 82120/ 85130	117 122/ 173
Grand Am <i>94390, Pro Springs pg. 137</i> <i>94006, upper ball joint pg. 157</i> <i>94011, lower ball joint pg. 157</i>	78-80	RWD	N/A	N/A		47700(*) 97140 95336 (22)	47700(*) 97140	84,84 138,138 136

CAR/MINI-VAN/SUV/TRUCK APPLICATIONS

PONTIAC-cont.			REAR			Thrust Plate	FRONT		Page
Model/Body Style	Year	Drive Type	CAMBER/TOOL	TOE/TOOL	Page		CASTER/TOOL	CAMBER/TOOL	
Grand Am <i>94006, upper ball joint pg. 157</i> <i>94017, 1/2" ext upper ball joint pg. 157</i> <i>94011, lower ball joint pg. 157</i>	73-75	RWD	N/A	N/A		47700(*) 97130 94378(22)	47700(*) 97130	84,84 138,138 136	
Grand Prix	97-08	FWD	81260	OEMA	117	N/A	81260	117	
Grand Prix	95-96	FWD	81280 82120/85130	OEMA/83850	117/173 122/173	N/A	N/A/85130	173	
Grand Prix	88-94	FWD	81280	OEMA	117	N/A	N/A/85130	173	
Grand Prix <i>94390, Pro Springs pg. 137</i> <i>94006, upper ball joint pg. 157</i> <i>94011, lower ball joint pg. 157</i>	78-87	RWD	N/A	N/A		47700(*) 97140 95336(22)	47700(*) 97140	84,84 138,138 136	
Grand Prix <i>94006, upper ball joint pg. 157</i> <i>94017, 1/2" ext upper ball joint pg. 157</i> <i>94011, lower ball joint pg. 157</i>	73-77	RWD	N/A	N/A		47700(*) 97130 94378(22)	47700(*) 97130	84,84 138,138 136	
Grand Prix	65-72	RWD	N/A	N/A		47700(*)	47700(*)	84,84	
GTO	04-06	RWD	N/A	OEMA		OEMA	OEMA 81260	117	
GTO <i>94391, Pro Springs (64-67) pg. 137</i> <i>94392, Pro Springs (68-72) pg. 137</i> <i>94001, upper ball joint pg. 157</i>	64-72	RWD	N/A	N/A		47700(*) 97110 94344(22)	47700(*) 97110	84,84 138,138 136	
LeMans	88-94	FWD	N/A	N/A		N/A	N/A		
LeMans <i>94390, Pro Springs pg. 137</i> <i>94006, upper ball joint pg. 157</i> <i>94011, lower ball joint pg. 157</i>	78-81	RWD	N/A	N/A		47700(*) 97140 95336(22)	47700(*) 97140	84,84 138,138 136	
LeMans <i>94006, upper ball joint pg. 157</i> <i>94017, 1/2" ext upper ball joint pg. 157</i> <i>94011, lower ball joint pg. 157</i>	73-77	RWD	N/A	N/A		47700(*) 97130 94378(22)	47700(*) 97130	84,84 138,138 136	
LeMans <i>94391, Pro Springs (64-67) pg. 137</i> <i>94392, Pro Springs (68-72) pg. 137</i> <i>94001, upper ball joint pg. 157</i>	64-72	RWD	N/A	N/A		47700(*) 97110 94344(22)	47700(*) 97110	84,84 138,138 136	
Montana SV6	02-07	AWD	OEMA	OEMA		N/A	81260	117	
Montana SV6	97-07	FWD	75600(1) 75800(1)	75600(1) 75800(1)	116,116 116,116	N/A	81260	117	
Phoenix	80-84	FWD	75400(1)	75400(1)	116,116	N/A	82110/85130	121/173	
Safari SW	80-89	RWD	N/A	N/A		47700(*)	47700(*)	84,84	
Solstice	06-10	RWD	OEMA 82070	OEMA 82070	120,120	OEMA 82070	OEMA 82070	120,120	
Sunbird	82-94	FWD	75400(1)	75400(1)	116,116	N/A	81280 82120/85130	117 122/173	
Sunfire	95-06	FWD	75400(1)	75400(1)	116,116	N/A	81260	117	
Tempest	95-06	FWD	75400(1)	75400(1)	116,116	N/A	81260	117	
Tempest <i>94391, Pro Springs (64-67) pg. 137</i> <i>94392, Pro Springs (68-72) pg. 137</i> <i>94001, upper ball joint pg. 157</i>	64-70	RWD	N/A	N/A		47700(*) 97110 94344(22)	47700(*) 97110	84,84 138,138 136	
Torrent	06-09	FWD/AWD	OEMA 87420	OEMA 87420	133,133	N/A	81260	117	

CAR/MINI-VAN/SUV/TRUCK APPLICATIONS

PONTIAC-cont.

REAR

FRONT

Model/Body Style	Year	Drive Type	CAMBER/TOOL	TOE/TOOL	Page	Thrust Plate	CASTER/TOOL	CAMBER/TOOL	Page
Trans Am	93-02	RWD	N/A	N/A			OEMA/83775	OEMA/83775	172,172
Trans Am	82-92	RWD	N/A	N/A			OEMA	OEMA 81280 82120/85130	117 122/173
Trans Am 94006, upper ball joint pg. 157 94017, 1/2" ext upper ball joint pg. 157 94011, lower ball joint pg. 157	70-81	RWD	N/A	N/A			47700(*) 97130 94378(22)	47700(*) 97130	84,84 138,138 136
Trans Am	69-69	RWD	N/A	N/A			47700(*) 97120 94374(22)	47700(*) 97120	84,84 138,138 136
Trans Sport	97-99	FWD	75600(1)	75600(1)	116,116		N/A	81260	117
Trans Sport	90-96	FWD	75600(1) 75800(1)	75600(1) 75800(1)	116,116 116,116		N/A	82110/85130	121/173
T1000	81-87	RWD	N/A	N/A			OEMA	OEMA	
Vibe w/ Independent Rear Suspension	09-10	FWD	OEMA 67440	OEMA	93		N/A	81290	117
Vibe	03-10	AWD	OEMA 67440	OEMA	93		N/A	81290	117
Vibe w/o Independent Rear Suspension NOTE: Vehicles with rear disc brakes may also need pn, 75970	03-10	FWD	75610(1)	75610(1)	116,116		N/A	81290	117

PORSCHE

718 Boxter (982)	17-19	RWD	OEMA 72600(34)/72120 72610(34)/72120	OEMA 72645	113/169/114 113/169		N/A	OEMA 72600(34)/72120 72610(34)/72120	113/169 113/169
718 Cayman (982)	17-19	RWD	OEMA 72600 (34)/72120 72610(34)/72120	OEMA 72645	113/169/114		N/A	OEMA 72610(34)/72120	113/169
911 (991)	12-19	RWD/AWD	OEMA	OEMA 72645	114		N/A	OEMA 72610(34)/72120	113/169
911 Except GT2/GT3 (997) 72630 can adjust setback.	05-11	RWD/AWD	OEMA 72600/72120 72610(34)/ 37995, 72120	OEMA 72630(34) 72640(34) 72645	113/169 113,113 164,169/114		72630	OEMA 72600/72120 72610(34)/72120	113/169 113/169
911 GT2/GT3 (997) 72630 can adjust setback.	05-11	RWD/AWD	OEMA	OEMA 72630(34) 72640(34) 72645	113 113 1147		N/A	OEMA	
911 (996) Except GT2/GT3 (997) 72630 can adjust setback.	99-04	RWD/AWD	OEMA 72600(34)/72120 72610(34)/ 37995, 72120	OEMA 72630(34) 72640(34) 72645	113/169 113,113 164,169/114		72630	OEMA 72600(34)/72120 72610(34)/72120	113/169 113/169
911	80-98	RWD/AWD	OEMA	OEMA			N/A	OEMA	
924	77-88	RWD	OEMA	OEMA			OEMA	81250	117
928	80-96	RWD	OEMA	OEMA			OEMA	OEMA	
944	82-91	RWD	OEMA	OEMA			OEMA	OEMA 81250	117
968	92-95	RWD	OEMA	OEMA			OEMA	OEMA	
Boxster (981) Except Headlight Leveling	13-16	RWD	OEMA 72610(34)/ 37995, 72120	OEMA, 72645	113,114 164,169		N/A	OEMA	
Boxster (987) Except Headlight Leveling 72630 can adjust setback.	05-12	RWD	OEMA 72600(34)/72120 72610(34)/ 37995, 72120	OEMA 72630(34) 72640(34) 72645	113/169 113,113 164,169/114		72630	OEMA 72600(34)/72120 72610(34)/72120	113/169 113/169
Boxster (986) 72630 can adjust setback.	97-04	RWD	OEMA 72600(34)/72120 72610(34)/ 37995, 72120	OEMA 72630(34) 72640(34) 72645	113/169 113,113 164,169/114		72630	OEMA 72600(34)/72120 72610(34)/72120	113/169 113/169
Cayenne	04-20	AWD	OEMA	OEMA			OEMA	OEMA	

Applications

Alignment Parts

Heavy Duty

OE Replacement

Racing/Builders

Tools

Brake and CV

Gear/Index

CAR/MINI-VAN/SUV/TRUCK APPLICATIONS

PORSCHÉ-cont.			REAR			Thrust Plate	FRONT		
Model/Body Style	Year	Drive Type	CAMBER/TOOL	TOE/TOOL	Page		CASTER/TOOL	CAMBER/TOOL	Page
Cayman (981) Except Headlight Leveling 72630 can adjust setback.	13-16	RWD	OEMA 72600(34)/72120 72610(34)/ 37995, 72120	OEMA 72630(34) 72640(34) 72645	113/169 113,113 164,169/114		72630 OEMA 72600(34)/72120 72610(34)/72120	113/169 113/169	
Cayman (987) Except Headlight Leveling 72630 can adjust setback.	06-12	RWD	OEMA 72600(34)/72120 72610(34)/ 37995, 72120	OEMA 72630(34) 72640(34) 72645	113/169 113,113 164,169/114		72630 OEMA 72600(34)/72120 72610(34)/72120	113/169 113/169	
Macan	15-19	AWD	OEMA	OEMA			N/A OEMA		
Panamera	17-19	RWD/AWD	OEMA	OEMA			N/A OEMA		
Panamera	10-16	RWD/AWD	OEMA	OEMA 72645	114		N/A OEMA		
RAM									
1500 (DT)	19-20	RWD/4WD	N/A	N/A			OEMA 82420	OEMA 82420	124,124
1500	11-18	RWD/4WD	N/A	N/A			OEMA 23940/72509 82420/37995	OEMA 23940/72509 82420/37995	78/169 124/164
1500 Classic	19-19	RWD/4WD	N/A	N/A			OEMA 23940/ 72509, 37995 82420	OEMA 23940/ 72509, 37995 82420	78,78 169,164 124,124
2500 <i>Stock Replacement Part</i>	14-20	RWD	N/A	N/A			OEMA 23610, 23615	OEMA	77,77
2500 <i>Stock Replacement Part</i>	14-20	4WD	N/A	N/A		■	23800(*)/ 23780, 72509 82386(16) 23610, 23615	23800(*)/ 23780, 72509	78,78 163,169 123 77,77
2500	11-13	RWD	N/A	N/A		■	OEMA	OEMA	
2500 <i>Stock Replacement Part</i>	11-13	4WD	N/A	N/A		■	23800(*)/ 23780, 72509 82386(16) 23610, 23615	23800(*)/ 23780, 72509	78,78 163,169 123 77,77
3500 w/ mono beam <i>Stock Replacement Part</i>	13-20	4WD	N/A	N/A		■	23800(*)/ 72509, 23780 82387(16) 23610, 23615	23800(*)/ 72509, 23780	78,78 163,169 123 77,77
3500 w/mono beam <i>Stock Replacement Part</i>	13-20	RWD	N/A	N/A		■	23800(*)/ 72509, 23780 82387(16) 23610, 23615	23800(*)/ 72509, 23780	78,78 163,169 123 77,77
3500 <i>Stock Replacement Part</i>	3-20	RWD	N/A	N/A		■	OEMA 23610, 23615	OEMA	77,77
3500	11-12	4WD	N/A	N/A		■	23800(*)/ 72509, 23780 82386(16)	23800(*)/ 72509, 23780	78,78 163,169 123
3500 w/mono beam	11-12	RWD	N/A	N/A		■	23800(*)/ 72509, 23780 82386(16)	23800(*)/ 72509, 23780	78,78 163,169 123
3500 w/o mono beam axle	11-12	RWD	N/A	N/A		■	OEMA	OEMA	
4500 / 5500	11-18	RWD/4WD	N/A	N/A		■	N/A	23850(*)/88360	78/175
C/V Tradesman	12-15	AWD	N/A	N/A			N/A	OEMA 81260 83170/85130	117 125/175
C/V Tradesman	12-15	FWD	71700(*1)	71700(*1)	104,104		N/A	OEMA 81260 83170/85130	117 125/175

Applications

CAR/MINI-VAN/SUV/TRUCK APPLICATIONS

RAM-cont.

Model/Body Style	Year	Drive Type	REAR			Thrust Plate	FRONT		
			CAMBER/TOOL	TOE/TOOL	Page		CASTER/TOOL	CAMBER/TOOL	Page
Promaster	14-20	FWD	N/A	N/A			N/A	N/A	
Promaster City	15-20	FWD	N/A	N/A			N/A	81250	117

SAAB

9-2X	05-07	AWD	67640 81260	OEMA 67640	99 117,99		N/A	81260	117
9-3	08-12	FWD/AWD	OEMA 82100	OEMA 82100	121,121		N/A	81250	117
9-3	03-09	FWD	OEMA 82100	OEMA 82100	121,121		N/A	81250	117
9-3	99-02	FWD	N/A	N/A			N/A	N/A	
9-3X	08-12	FWD/AWD	N/A	N/A			N/A	N/A	
9-4X	11-11	FWD/AWD	N/A	N/A			N/A	N/A	
9-5	10-12	FWD/AWD	N/A	N/A			N/A	N/A	
9-5 w/ Auto Leveling Headlights	00-09	FWD	N/A	OEMA			N/A	81250	117
9-5 w/o Auto Leveling Headlights	00-09	FWD	67270	OEMA	90		N/A	81250	117
9-7X	05-09	AWD	N/A	N/A			N/A/83785	OEMA/83785	172,172
99	80-80	FWD	N/A	N/A			47700(*)	47700(*)	84,84
900	94-99	FWD	N/A	N/A			N/A	N/A	
900	80-93	FWD	N/A	N/A			47700(*)	47700(*)	84,84
9000	86-98	FWD	N/A	N/A			N/A	81250	117

SATURN

Astra	08-09	FWD	N/A	N/A			N/A	81250	117
Aura	07-09	FWD	OEMA 75400(17) 82100	OEMA 75400(17) 82100	116,116 121,121		N/A	81250	117
Ion	03-07	FWD	75400(1)	75400(1)	116,116		N/A	81250	117
L-Series	00-05	FWD	67270	OEMA			N/A	81250	117
Outlook	07-10	FWD/AWD	OEMA 82105 82106	OEMA 82105	121,121 121		N/A	81280	117
Stock Replacement Part			15647		158				
Relay	05-08	AWD	OEMA	OEMA			N/A	81260	117
Relay	05-08	FWD	75600(1) 75800(1)	75600(1) 75800(1)	116,116 116,116		N/A	81260	117
S-Series	91-02	FWD	81260	OEMA 85600	117 WB		OEMA	81260	117
Sky	07-10	RWD	OEMA 82070	OEMA 82070	120,120		OEMA 82070	OEMA 82070	120,120
Vue	06-09	FWD/AWD	OEMA 87420	OEMA 87420	133,133		N/A	81260	117
Vue	02-05	FWD/AWD	OEMA	OEMA			N/A	81260	117

SCION

FR-S	13-16	RWD	67660/67647 72509	OEMA 67655/37995	100/168 169/100,164		N/A	81305	118
Stock Replacement Part			16210		151				
iA	16-16	FWD	N/A	N/A			N/A	81250	117
iM	16-16	FWD	67487	OEMA 67800	96 101		N/A	81290	117
Stock Replacement Part			12030		150				
iQ	11-15	FWD	75600(1)	75600(1)	116,116		N/A	81270	117
tC	11-16	FWD	67487 75600(1)	OEMA 67800 75600(1)	96 116,101 116		N/A	81290	117
Stock Replacement Part			12030		150				
tC	05-10	FWD	OEMA 67485	OEMA	95		N/A	81290	117
Stock Replacement Part			12030		150				

Applications

Alignment Parts

Heavy Duty

OE Replacement

Racing/Builders

Tools

Brake and CV

Gear/Index

CAR/MINI-VAN/SUV/TRUCK APPLICATIONS

SCION-cont.			REAR			Thrust Plate	FRONT		
Model/Body Style	Year	Drive Type	CAMBER/TOOL	TOE/TOOL	Page		CASTER/TOOL	CAMBER/TOOL	Page
xA	04-07	FWD	75600(1)	75600(1)	116,116		N/A	81260	117
xB	08-15	FWD	75600(1)	75600(1)	116,116		N/A	81290	117
xB	04-07	FWD	75600(1)	75600(1)	116,116		N/A	81260	117
xD	08-14	FWD	75600(1)	75600(1)	116,116		N/A	81270	117
SMART									
Fortwo	17-19	RWD	N/A	N/A			N/A	81260	117
Fortwo Electric Drive	16-16	RWD	N/A	N/A			N/A	N/A	
Fortwo Gas Engine	16-16	RWD	N/A	N/A			N/A	81260	117
Fortwo	07-15	RWD	N/A	N/A			N/A	N/A	
STERLING									
Bullet 45	08-10	RWD	N/A	N/A			N/A	23850(*)/88360	78/175
Bullet 45	08-10	4WD	N/A	N/A			N/A	23850(*)/88360	78/175
Bullet 55	08-10	RWD	N/A	N/A			N/A	23850(*)/88360	78/175
Bullet 55	08-10	4WD	N/A	N/A			N/A	23850(*)/23780, 72509	78/163,169
SUBARU									
Ascent	19-20	AWD	N/A	OEMA			N/A	81305	118
Baja	03-06	AWD	67665/74940	OEMA 67667, 67668	100/169 100,100		N/A	OEMA 81305	118
Stock Replacement Part			16210		151				
BRZ	13-20	RWD	67660/67647 72509	OEMA 67655/37995	100/168 169/100,164		N/A	OEMA 81305	118
Stock Replacement Part			16210		151				
Crosstrek	16-20	AWD	67660/67647 72509	OEMA 67655/37995	100/168 169/100,164		N/A	OEMA 81305	118
Stock Replacement Part			16210		151				
Forester	09-20	AWD	67660/67647 72509	OEMA 67655/37995	100/168 169/100,164		N/A	OEMA 81305	118
Stock Replacement Part			16210		151				
Forester	98-08	AWD	81260	OEMA	117		N/A	OEMA 81305	118
Impreza	17-20	AWD	67660/67647 72509	OEMA	100/168 169		N/A	OEMA 81305	118
Impreza	08-16	AWD	67660/67647 72509	OEMA 67655/37995	100/168 169/100,164		N/A	OEMA 81305	118
Stock Replacement Part			16210		151				
Impreza	93-07	AWD	67640 81260	OEMA 67640	99 117,99		N/A	OEMA 81305	118
Justy	87-94	FWD/AWD	N/A	OEMA			N/A	N/A	
Legacy	10-20	AWD	67660/67647 72509	OEMA 67655/37995	100/168 169/100,164		N/A	OEMA 81305	118
Stock Replacement Part			16210		151				
Legacy	00-09	AWD	67665/74940	OEMA 67667, 67668	100/169 100,100		N/A	OEMA 81305	118
Stock Replacement Part			16210		151				
Legacy	90-99	AWD	67640 81260	OEMA 67640	99 117,99		N/A	OEMA 81305	118
Outback	10-20	AWD	67660/67647 72509	OEMA 67655/37995	100/168 169/100,164		N/A	OEMA 81305	118
Stock Replacement Part			16210		151				
Outback	00-09	AWD	67665/74940	OEMA 67667, 67668	100/169 100,100		N/A	OEMA 81305	118
Stock Replacement Part			16210		151				
Outback	90-99	AWD	67640 81260	OEMA 67640	99 117,99		N/A	OEMA 81305	118

Applications

CAR/MINI-VAN/SUV/TRUCK APPLICATIONS

SUBARU-cont.

REAR

FRONT

Model/Body Style	Year	Drive Type	CAMBER/TOOL	TOE/TOOL	Page	Thrust Plate	CASTER/TOOL	CAMBER/TOOL	Page
SVX	92-97	FWD/AWD	67640 81260	OEMA	99 117		N/A	OEMA 81305	118
Tribeca	11-15	AWD	N/A	OEMA			N/A	OEMA 81305	118
Stock Replacement Part			16210		11				
Tribeca	06-10	AWD	N/A	OEMA 67667, 67668			N/A	OEMA 81305	118
WRX Inc. STi	08-20	AWD	67660/67647 72509	OEMA 67655/37995	100/168 169/100,164		N/A	OEMA 81305	118
Stock Replacement Part			16210		151				
WRX Inc. STi	02-07	AWD	67640 81260	OEMA 67640	99 117,99		N/A	OEMA 81305	118
XV Crosstrek	12-15	AWD	67660/67647 72509	OEMA 67655/37995	100/168 169/100,164		N/A	OEMA 81305	118
Stock Replacement Part			16210		151				

SUZUKI

Aerio Inc. SX	03-07	FWD/AWD	81250	OEMA	117		N/A	81250	117
Equator	09-12	RWD/4WD	N/A	N/A			25540 87520	25540 87520	82,82 133,133
Stock Replacement Part			21035		152				
Esteem	95-02	FWD/AWD	81250	OEMA	117		OEMA	81250	117
Forenza Inc. Wagon	04-08	FWD	81250	OEMA	117		N/A	81250	117
Forsa	85-88	FWD	N/A	N/A			N/A	81250	117
Grand Vitara	99-12	FWD/AWD	N/A	N/A			N/A	81250	117
Kizashi	10-13	FWD/AWD	OEMA	OEMA			N/A	81260	117
Reno	05-09	FWD	81250	OEMA	117		N/A	81250	117
Samurai	86-96	RWD	N/A	N/A			N/A	N/A	
Samurai	86-96	4WD	N/A	N/A			88905	88905	WB,WB
Sidekick	89-98	RWD/4WD	N/A	N/A			N/A	81250	117
Swift	89-01	FWD	N/A	OEMA			OEMA	81250	117
SX4	07-12	FWD/AWD	N/A	N/A			N/A	81260	117
Verona	04-08	FWD	N/A	OEMA			OEMA	81250	117
Vitara	99-04	FWD/AWD	N/A	N/A			N/A	81250	117
X-90	97-01	RWD/4WD	N/A	N/A			N/A	81250	117
XL-7	07-11	FWD/AWD	OEMA 87420	OEMA 87420	133,133		N/A	81260	117
XL-7	01-06	RWD/4WD	N/A	N/A			N/A	81250	117

TEMSA

See our Heavy Duty Section		pages 141-149							
----------------------------	--	---------------	--	--	--	--	--	--	--

TESLA

Model 3	18-19	RWD/AWD	N/A	OEMA			N/A	N/A	
Model S	12-19	RWD	N/A	OEMA			OEMA	OEMA	
Model X	16-19	AWD	N/A	OEMA			OEMA	OEMA	

TOYOTA

4Runner	10-20	RWD/4WD	N/A	N/A			OEMA 25440/40915 25480	OEMA 25440/40915 25480	80/165 81,81
Replacement Part			25950		152				
4Runner	03-09	RWD/4WD	N/A	N/A			OEMA 25435/40915 25480	OEMA 25435/40915 25480	80/165 81,81
Replacement Part			25950		152				
4Runner	96-02	RWD/4WD	N/A	N/A			OEMA 25430/40915 25460	OEMA 25430/40915 25460	80/165 81,81
Replacement Part			25945		152				
4Runner	90-95	RWD	N/A	N/A			47700(*)	47700(*)	84,84

CAR/MINI-VAN/SUV/TRUCK APPLICATIONS

TOYOTA-cont.			REAR			Thrust Plate	FRONT		
Model/Body Style	Year	Drive Type	CAMBER/TOOL	TOE/TOOL	Page		CASTER/TOOL	CAMBER/TOOL	Page
4Runner	90-95	4WD	N/A	N/A		OEMA 25425	OEMA 25425	80,80	
4Runner	86-89	4WD	N/A	N/A		■ OEMA 25425	OEMA 25425	80,80	
4Runner	84-85	4WD	N/A	N/A		■ OEMA 88901(*)	OEMA 88901(*)	WB,WB	
4Runner	84-89	RWD	N/A	N/A		■ 47700(*)	47700(*)	84,84	
86	17-20	RWD	67660/ 72509 67647	OEMA 67655/ 37995	100/ 169 168/100,164		N/A	OEMA 81305	118
Avalon	19-20	FWD	N/A	OEMA		N/A	81290	117	
Avalon	13-18	FWD	81290	N/A	117	N/A	81290	117	
Avalon	95-12	FWD	81270	OEMA	117	N/A	81290 82120/ 85130	117 122/ 173	
C-HR	18-20	FWD	N/A	OEMA		N/A	81290	117	
Camry Inc. Hybrid	18-20	FWD	N/A	OEMA		N/A	81290	117	
Camry Inc. Hybrid	12-17	FWD	81290	OEMA	117	N/A	81290	117	
Camry Inc. Hybrid	92-11	FWD	81270	OEMA	117	N/A	81290 82120/ 85130	117 122/ 173	
Camry	88-91	FWD/AWD	81270	OEMA	117	85690, 85695	81290 82120/ 85130	WB,WB,117 122/ 173	
Camry Wagon	88-96	FWD/AWD	81270	OEMA	117	85690, 85695	81290 82120/ 85130	WB,WB,117 122/ 173	
Camry	83-87	FWD/AWD	81270	OEMA	117	OEMA 85690, 85695	OEMA 81290 82120/ 85130	WB,WB,117 122/ 173	
Carina	72-73	RWD	N/A	N/A		N/A	N/A		
Celica	00-05	FWD	OEMA 67440	OEMA	93	N/A	81270	117	
Celica All-Trac	89-92	AWD	N/A	N/A		N/A	81270	117	
Celica	86-99	FWD	81270	OEMA	117	N/A	81270	117	
Celica Inc. Supra	71-85	RWD	N/A	N/A		N/A	N/A		
Corolla w/Multi-Link Rear Susp.	19-20	FWD	N/A	OEMA		N/A	81290	117	
Corolla iM	17-18	FWD	67487	OEMA 67800	96 101	N/A	81290	117	
Stock Replacement Part			12030		150				
Corolla w/Beam-Type Rear Susp.	09-19	FWD	75600 (1)	75600 (1)	116,116	N/A	81290	117	
Corolla <i>NOTE: Vehicles with rear disc brakes may also need pn, 75970</i>	03-08	FWD	75610 (1)	75610 (1)	116,116	N/A	81270	117	
Corolla All-Trac	89-92	AWD	N/A	N/A		N/A	81270	117	
Corolla	88-02	FWD	81250	OEMA	117	N/A	81270	117	
Corolla	84-87	FWD	81250	OEMA	117	N/A	81250	117	
Corolla	75-87	RWD	N/A	N/A		OEMA	N/A		
Cressida	89-92	RWD	OEMA	OEMA		OEMA	N/A		
Cressida	85-88	RWD	N/A	OEMA		85690, 85695	N/A	WB,WB	
Cressida	83-84	RWD	N/A	OEMA		OEMA	N/A		
Cressida Wagon	83-88	RWD	N/A	N/A		OEMA	N/A		
Cressida	82-82	RWD	N/A	N/A		OEMA	N/A		
Cressida	78-81	RWD	N/A	N/A		N/A	N/A		
Echo	00-06	FWD	75600 (1)	75600 (1)	116,116	N/A	81260	117	

CAR/MINI-VAN/SUV/TRUCK APPLICATIONS

TOYOTA-cont.

REAR			FRONT						
Model/Body Style	Year	Drive Type	CAMBER/TOOL	TOE/TOOL	Page	Thrust Plate	CASTER/TOOL	CAMBER/TOOL	Page
FJ Cruiser	10-14	RWD/4WD	N/A	N/A			OEMA 25440/ 40915 25480	OEMA 25440/ 40915 25480	80/ 165 81,81
Replacement Part			25950		152				
FJ Cruiser	07-09	RWD/4WD	N/A	N/A			OEMA 25435/ 40915 25480	OEMA 25435/ 40915 25480	80/ 165 81,81
Replacement Part			25950		152				
Highlander	14-20	FWD/AWD	N/A	OEMA			N/A	81290	117
Highlander	08-13	FWD/AWD	81290	OEMA	117		N/A	81290	117
Highlander	01-07	FWD/AWD	81270	OEMA	117		N/A	81290	117
Land Cruiser 200 Series	08-20	4WD	N/A	N/A			OEMA 25450/ 40915 25465	OEMA 25450/ 40915 25465	80/ 165 81,81
Replacement Part			25965		152				
Land Cruiser 100 Series	98-07	4WD	N/A	N/A			OEMA 25455	OEMA 25455	80,80
Replacement Part			25955		152				
Land Cruiser 80 Series	91-97	4WD	N/A	N/A		■	88915, 88920	88915, 88920	134,134
Replacement Part			25960		152				
Land Cruiser 40,60,70 Series	65-90	4WD	N/A	N/A		■	88901(*)	88901(*)	WB,WB
Matrix	03-13	AWD	OEMA 67440	OEMA	93		N/A	81290	117
Matrix w/ Independent Rear Suspension	03-13	FWD	OEMA 67440	OEMA	93		N/A	81290	117
Matrix w/o Independent Rear Suspension <i>NOTE: Vehicles with rear disc brakes may also need pn, 75970</i>	03-13	FWD	75610 (1)	75610 (1)	116,116		N/A	81290	117
Mirai	16-20	FWD	N/A	N/A			N/A	81290	117
MR2	91-97	RWD	81270	OEMA	117		OEMA	81270	117
MR2	85-90	RWD	OEMA 81250	OEMA	117		OEMA	OEMA 81250	117
MR2 Spyder	00-05	RWD	81270	OEMA	117		OEMA	81260	117
Paseo	92-97	FWD	N/A	N/A			N/A	81270	117
Pickup	86-94	4WD	N/A	N/A		■	OEMA 25425/ 40915	OEMA 25425/ 40915	80/ 165
Pickup	79-85	4WD	N/A	N/A		■	OEMA 88901(*)	OEMA 88901(*)	WB,WB
Pickup	74-94	RWD	N/A	N/A		■	47700(*)	47700(*)	84,84
Previa	90-97	RWD/AWD	N/A	N/A			N/A	81290 82120/ 85130	117 122/ 173
Prius Inc. Prime	16-20	FWD	N/A	OEMA			N/A	81290	117
Prius V	12-17	FWD	N/A	N/A			N/A	81290	117
Prius C	12-19	FWD	N/A	N/A			N/A	81270	117
Prius	10-15	FWD	75600 (1)	75600 (1)	116,116		N/A	81290	117
Prius	01-09	FWD	75600 (1)	75600 (1)	116,116		N/A	81270	117
RAV4	19-20	AWD/FW	N/A	OEMA			N/A	81290	117
RAV4	11-18	FWD/AWD	67810, 67811	OEMA 67806/ 37995	102,102 102/ 164		N/A	81290	117
RAV4	06-10	FWD/AWD	67810, 67811	67806/ 37995	102/ 164		N/A	81290	117
RAV4	01-05	FWD/AWD	OEMA 25380	OEMA 25380	80,80		N/A	81270	117
RAV4	96-00	FWD/AWD	OEMA	OEMA			N/A	81270	117

Applications

Alignment Parts

Heavy Duty

OE Replacement

Racing/Builders

Tools

Brake and CV

Gear/Index

CAR/MINI-VAN/SUV/TRUCK APPLICATIONS

TOYOTA-cont.			REAR			Thrust Plate	FRONT		
Model/Body Style	Year	Drive Type	CAMBER/TOOL	TOE/TOOL	Page		CASTER/TOOL	CAMBER/TOOL	Page
Sequoia	08-19	RWD/4WD	OEMA	OEMA			OEMA 25450/ 40915 25490	OEMA 25450/ 40915 25490	80/ 165 81,81
Sequoia	01-07	RWD/4WD	N/A	N/A			OEMA 25445/ 40915 25485	OEMA 25445/ 40915 25485	80/ 165 81,81
Sienna	11-20	FWD/AWD	71600(*)	71600(*)	116,116		N/A	81290	117
Sienna	04-10	AWD	N/A	N/A			N/A	81290 82120/ 85130	117 122/ 173
Sienna	98-10	FWD	71000(*)	71000(*)	102,102		N/A	81290 82120/ 85130	117 122/ 173
Solara	92-09	FWD	81270	OEMA	117		N/A	81290 82120/ 85130	117 122/ 173
Starlet	81-84	RWD	N/A	N/A			85690, 85695	N/A	WB,WB
Supra Mark 4	92-02	RWD	OEMA	OEMA			OEMA	OEMA	
Supra Mark 3	86-91	RWD	OEMA	OEMA			OEMA	OEMA	
Supra Celica Mark 2	82-85	RWD	N/A	OEMA			OEMA	N/A	
Supra Celica Mark 1	78-81	RWD	N/A	N/A			OEMA	N/A	
Tacoma	16-20	RWD/4WD	N/A	N/A		■	OEMA 25440/ 40915 25470	OEMA 25440/ 40915 25470	80/ 165 81,81
Tacoma	05-15	4WD	N/A	N/A		■	OEMA 25435/ 40915 25470	OEMA 25435/ 40915 25470	80/ 165 81,81
Tacoma w/ 6 lug axle	05-15	RWD	N/A	N/A		■	OEMA 25435/ 40915 25470	OEMA 25435/ 40915 25470	80/ 165 81,81
Tacoma w/ 6 lug axle	98-04	RWD	N/A	N/A		■	OEMA 25430/ 40915 25460	OEMA 25430/ 40915 25460	80/ 165 81,81
Tacoma	96-04	4WD	N/A	N/A		■	OEMA 25430/ 40915 25460	OEMA 25430/ 40915 25460	80/ 165 81,81
Tacoma	95-95	4WD	N/A	N/A		■	OEMA 25425/ 40915 25460	OEMA 25425/ 40915 25460	80/ 165 81,81
Tacoma w/ 5 lug axle	95-15	RWD	N/A	N/A		■	OEMA	OEMA	
Tercel	87-99	FWD	N/A	N/A			N/A	OEMA 81270	117
Tercel	83-86	FWD	N/A	N/A			85690, 85695	OEMA 81270	WB,WB 117
Tercel	83-86	4WD	81250	OEMA	117		85690, 85695	OEMA 81270	WB,WB 117
Tercel Wagon	83-88	FWD	N/A	OEMA			OEMA	OEMA 81270	117
Tercel Wagon	83-88	4WD	81250	OEMA	117		85690, 85695	OEMA 81270	WB,WB 117
Tundra	07-19	RWD/4WD	N/A	N/A		■	OEMA 25450/ 40915 25490	OEMA 25450/ 40915 25490	80/ 165 81,81
Tundra	00-06	RWD/4WD	N/A	N/A		■	OEMA 25445/ 40915 25485	OEMA 25445/ 40915 25485	80/ 165 81,81
T100	93-98	RWD	N/A	N/A		■	47700(*)	47700(*)	84,84
T100	93-98	4WD	N/A	N/A		■	OEMA 25425/ 40915	OEMA 25425/ 40915	80/ 165
Van	86-89	RWD/AWD	N/A	N/A			OEMA	OEMA	
Venza	09-15	FWD/AWD	81290	OEMA	117		N/A	81290	117

Applications

CAR/MINI-VAN/SUV/TRUCK APPLICATIONS

TOYOTA-cont.

REAR

FRONT

Model/Body Style	Year	Drive Type	CAMBER/TOOL	TOE/TOOL	Page	Thrust Plate	CASTER/TOOL	CAMBER/TOOL	Page
Yaris Sedan	19-19	FWD	N/A	N/A			N/A	81250	117
Yaris iA	17-18	FWD	N/A	N/A			N/A	81250	117
Yaris	12-18	FWD	N/A	N/A			N/A	81270	117
Yaris	07-11	FWD	75600(1)	75600(1)	116,116		N/A	81270	117

VOLKSWAGEN

Arteon	19-20	FWD/AWD	OEMA 81335	OEMA	118		N/A	N/A	
Atlas Inc. Cross Sport	18-20	FWD/AWD	OEMA	OEMA			N/A	N/A	
Beetle w/Beam Type Rear Susp.	11-18	FWD	N/A	N/A			N/A	N/A	
Beetle w/Multi-Link Rear Susp.	11-18	FWD	OEMA 81335	OEMA	118		N/A	N/A	
Beetle	98-10	FWD	71500(*) (1)/87530	71500(*) (1)/87530	103/174		81340	81340	119,119
Cabrio <i>75200 must be used with 10408</i>	95-02	FWD	75200(1)+10408	75200(1)+10408	116,73		N/A	81250	117
Cabrioleto <i>75200 must be used with 10408</i>	85-94	FWD	75200(1)+10408	75200(1)+10408	116,73		N/A	81250	117
Corrado <i>75200 must be used with 10408</i>	90-94	FWD	75200(1)+10408	75200(1)+10408	116,73		N/A	81250	117
CC	09-16	FWD/AWD	OEMA 81335	OEMA	118		N/A	N/A	
Dasher <i>75200 must be used with 10408</i>	73-81	FWD	75200(1)+10408	75200(1)+10408	116,73		N/A	OEMA	
Eos	14-16	FWD	OEMA	OEMA			N/A	N/A	
Eos	07-13	FWD	OEMA 81335	OEMA	118		N/A	N/A	
EuroVan	93-08	FWD/AWD	N/A	OEMA			N/A	OEMA	
Fox <i>75200 must be used with 10408</i>	87-94	FWD	75200(1)+10408	75200(1)+10408	116,73		N/A	OEMA	
Golf (MK7) w/Beam Type Rear Susp.	15-19	FWD/AWD	N/A	N/A			N/A	N/A	
Golf (MK7) w/Multi-Link Rear Susp.	15-19	FWD/AWD	OEMA 81335	OEMA	118		N/A	N/A	
Golf	10-14	AWD/FWD	OEMA 81335	OEMA	118		N/A	N/A	
Golf R32	08-08	AWD	OEMA 81335	OEMA	118		N/A	N/A	
Golf R32	04-04	AWD	N/A	N/A			81340	81340	119,119
Golf	99-06	FWD	71500(*) (1)/87530	71500(*) (1)/87530	103/174		81340	81340	119,119
Golf <i>75200 must be used with 10408</i>	84-98	FWD	75200(1)+10408	75200(1)+10408	116,73		N/A	81250	117
GLI	05-18	FWD	OEMA 81335	OEMA	118		N/A	N/A	
GTI	06-19	FWD	OEMA 81335	OEMA	118		N/A	N/A	
GTI	99-06	FWD	71500(*) (1)/87530	71500(*) (1)/87530	103/174		81340	81340	119,119
GTI <i>75200 must be used with 10408</i>	82-98	FWD	75200(1)+10408	75200(1)+10408	116,73		N/A	81250	117
Jetta(A7) w/Multi-Link Rear Susp.	19-20	FWD	OEMA 81335	OEMA	118		N/A	N/A	
Jetta (A7) w/Beam Type Rear Susp.	19-20	FWD	N/A	N/A			N/A	N/A	
Jetta (A6) w/Multi-Link Rear Susp.	11-18	FWD	OEMA 81335	OEMA	118		N/A	N/A	
Jetta (A6) w/Beam Type Rear Susp.	11-13	FWD	N/A	N/A			N/A	N/A	
Jetta (A5) w/Multi-Link Rear Susp.	05-10	FWD	OEMA 81335	OEMA	118		N/A	N/A	
Jetta (A4) w/Beam Type Rear Susp.	99-05	FWD	71500(*) (1)/87530	71500(*) (1)/87530	103/174		81340	81340	119,119
Jetta <i>75200 must be used with 10408</i>	80-98	FWD	75200(1)+10408	75200(1)+10408	116,73		N/A	81250	117

Applications

Alignment Parts

Heavy Duty

OE Replacement

Racing/Builders

Tools

Brake and CV

Gear/Index

CAR/MINI-VAN/SUV/TRUCK APPLICATIONS

VOLKSWAGEN-cont.			REAR			Thrust Plate	FRONT		
Model/Body Style	Year	Drive Type	CAMBER/TOOL	TOE/TOOL	Page		CASTER/TOOL	CAMBER/TOOL	Page
Passat (B7/B8)	11-19	FWD	OEMA 81335	OEMA	118		N/A	N/A	
Passat (B6)	06-10	FWD/AWD	OEMA 81335	OEMA	118		N/A	N/A	
Passat (B5)	98-05	AWD	OEMA	OEMA			81353 81351, 81352 81358	81353 81351, 81352 81358	119,119 119,119 119,119
Replacement Part							21040		152
Passat (B5)	98-05	FWD	75600(1)+10408 75800(1)+10408	75600(1)+10408 75800(1)+10408	116,73 116,73		81353 81351, 81352 81358	81353 81351, 81352 81358	119,119 119,119 119,119
Replacement Part							21040		152
Passat (B4)	90-97 75200 must be used with 10408	FWD	75200(1)+10408	75200*(1)+10408	116,73		N/A	81250	117
Phaeton	04-06	AWD	OEMA	OEMA			81373 81371, 81372 81378	81373 81371, 81372 81378	119,119 119,119 119,119
Replacement Part							21040		152
Quantum	82-89	FWD	75200(1)	75200(1)	116,116		N/A	OEMA	
Rabbit	06-09	FWD	OEMA 81335	OEMA	118		N/A	N/A	
Rabbit	74-84	FWD	75200(1)	75200(1)	116,116		N/A	81250	117
Routan	09-14	FWD	71700*(1)	71700*(1)	104,104		N/A	OEMA 81260 83170/85130	117 125/173
Scirocco	74-91	FWD	75200(1)	75200(1)	116,116		N/A	OEMA	
Tiguan	09-19	FWD/AWD	OEMA 81335	OEMA	118		N/A	N/A	
Touareg	04-17	AWD	OEMA	OEMA			OEMA	OEMA	
Vanagon	86-91	RWD/AWD	OEMA	OEMA			OEMA	OEMA	
VOLVO									
240	80-91	RWD	N/A	N/A			N/A	OEMA	
740	85-93	RWD	N/A	N/A			OEMA	N/A	
760	83-94	RWD	OEMA	OEMA			OEMA	N/A	
850 GLT	93-97	FWD	N/A	OEMA			N/A	81250	117
940	85-95	RWD	N/A	N/A			OEMA	N/A	
960	95-97	RWD	OEMA	OEMA			N/A	81250	117
C30	08-13	FWD	67420 81310	OEMA	93 118		N/A	N/A	
C70	06-13	FWD	67420	OEMA	93		N/A	N/A	
C70	98-05	FWD	N/A	N/A			N/A	81250	117
S40	04-12	FWD/AWD	67420 81310	OEMA	93 118		N/A	N/A	
S40	00-03	FWD	OEMA	OEMA			N/A	81250	117
S60	11-20	FWD/AWD	N/A	OEMA			N/A	N/A	
S60	01-10	FWD/AWD	N/A	OEMA			N/A	81260	117
S70	98-00	FWD/AWD	N/A	OEMA			N/A	81250	117
S80	07-15	FWD/AWD	N/A	N/A			N/A	N/A	
S80	99-06	FWD/AWD	N/A	OEMA			N/A	81260	117
S90	17-20	FWD/AWD	N/A	OEMA			N/A	N/A	
S90	97-98	RWD	N/A	OEMA			OEMA	81250	117
V40	00-03	FWD	OEMA	OEMA			N/A	81250	117
V50	04-11	FWD/AWD	67420 81310	OEMA	93 118		N/A	N/A	
V60	11-20	FWD/AWD	N/A	OEMA			N/A	N/A	

CAR/MINI-VAN/SUV/TRUCK APPLICATIONS

VOLVO-cont.

REAR

FRONT

Model/Body Style	Year	Drive Type	CAMBER/TOOL	TOE/TOOL	Page	Thrust Plate	CASTER/TOOL	CAMBER/TOOL	Page
V70	08-10	FWD/AWD	N/A	OEMA			N/A	N/A	
V70	01-07	FWD/AWD	N/A	OEMA			N/A	81260	117
V70	98-00	FWD/AWD	N/A	OEMA			N/A	81250	117
V90	17-20	AWD/FW	N/A	OEMA			N/A	N/A	
V90	97-98	RWD	N/A	OEMA			OEMA	81250	117
XC40	18-20	AWD	N/A	OEMA			N/A	N/A	
XC60	09-20	AWD	N/A	OEMA			N/A	N/A	
XC70	08-16	FWD/AWD	N/A	OEMA			N/A	N/A	
XC70	01-07	FWD/AWD	N/A	OEMA			N/A	81260	117
XC90	16-20	FWD/AWD	N/A	OEMA			N/A	N/A	
XC90	03-15	FWD/AWD	N/A	OEMA			N/A	81260	117

VOLVO & WHITE TRACTORS (OTR)

See our Heavy Duty Section pages 141-149

FOOTNOTES:

Labor times have been removed from the Sourcebook. SPC recommends consulting a Labor Time Guide for the Remove and Replace labor time for the appropriate part. Please review the SPC product installation instructions for any additional time required such as grinding. Add time as needed for the additional adjustments allowed. Always pre-check the vehicle for corrosion or modifications which might affect installation time.

N/A = No Available Adjuster • **OEMA** = Original Equipment Manufacturer Adjustment • (*) = Series P/N, see page for correct size

- (1) CAUTION: Check for caliper to rotor clearance with disc brakes. Use spacer set 75970 as necessary to keep caliper centered on rotor
- (2) All EXCEPT RWD 1500 • (3) Honda S2000 Ball Joint - Rear Application - Only for 17" rims or larger • (4) Check Bolt Length BEFORE Cutting Hole
- (6) LH Tie Rod Adjusting Sleeve Replacement • (7) Bolts, 73415, (pg. 115) are necessary for changes greater than 3/4"
- (8) Recommended for vehicles lowered more than 1.5" • (9) Will not work on 1988-89 models with welded-in ball joint
- (10) M3 Only, caster will decrease by 2 degrees • (11) Pinion Angle Adj. Part No. 82370 (pg. 122) • (12) Limited camber range of +/-1.0°
- (13) Center stock camber and toe adjusters before calculating shim change • (14) 69330 included w/69300 or 69400 • (15) Not for use w/disc brakes
- (16) Can be used for Caster or Pinion Angle • (17) Footnotes 1 and 13 • (18) Preferred • (19) Rear Pinion Angle • (20) Except Sti
- (21) Series P/N, Not for use with ABS • (22) Lower Arm 69400 • (23) Except Type R Lower Arm • (24) Rear Wheel Drive Only • (25) 92-96 Only
- (26) 92-98 Only • (27) C10 and C15 • (28) Footnote 1, include the next part number • (29) Include the next part number • (30) With 10mm Bolt
- (31) With 12mm Bolt • (32) All Except AMG models • (33) 1988-91 1500 - 43mm Bushings Only • (34) Models equipped with taller hydraulic bushings must be pressed out and reused from the original control arm or the 72360 trailing link can be used if applicable • (SW) Station Wagon • (L) Lower Stock Replacement Part - This part matches the OE Part • **Replacement Part** - This part fits like an OE part, but improves on the OE part's construction

■ Thrust Plate available for this vehicle - for more information see page 85

All products from Specialty Products Company are intended for use by professional installers only.

Entire contents © 2020 Niwot Corporation, dba Specialty Products Company®.

All rights reserved, reproduction in whole or in part without permission is prohibited.

MODEL YEAR (V.I.N. Tag Location)

*NOTE: Beginning in 1980 or 1981, all domestic vehicle manufacturers and most import manufacturers refer to the year of vehicle manufacture in the V.I.N. Tag as listed below:

Letter/Number shown in 10th digit of V.I.N. tag.

YEAR DESIGNATION	YEAR DESIGNATION	YEAR DESIGNATION
1981 B	1995 S	2009 9
1982 C	1996 T	2010 A
1983 D	1997 V	2011 B
1984 E	1998 W	2012 C
1985 F	1999 X	2013 D
1986 G	2000 Y	2014 E
1987 H	2001 1	2015 F
1988 J	2002 2	2016 G
1989 K	2003 3	2017 H
1990 L	2004 4	2018 J
1991 M	2005 5	2019 K
1992 N	2006 6	2020 L
1993 P	2007 7	2021 M
1994 R	2008 8	2022 N

CONVERSION TABLE - Toe Readings

Inches	Degrees	Metric MM	Minutes of Degrees
.03 (1/32)	.06° (1/16°)	0.8	3.75'
.06 (1/16)	.13° (1/8°)	1.6	7.50'
.09 (3/32)	.19° (3/16°)	2.4	11.25'
.12 (1/8)	.25° (1/4°)	3.2	15.00'
.16 (5/32)	.31° (5/16°)	4.0	18.75'
.19 (3/16)	.38° (3/8°)	4.8	22.50'
.22 (7/32)	.44° (7/16°)	5.6	26.25'
.25 (1/4)	.50° (1/2°)	6.4	30.00'
.28 (9/32)	.56° (9/16°)	7.1	33.75'
.31 (5/16)	.63° (5/8°)	7.9	37.50'
.34 (11/32)	.69° (11/16°)	8.7	41.25'
.37 (3/8)	.75° (3/4°)	9.5	45.00'
.41 (13/32)	.81° (13/16°)	10.3	48.75'
.44 (7/16)	.88° (5/8°)	11.1	52.50'
.47 (15/32)	.94° (15/16°)	11.9	56.25'
.50 (1/2)	1.00° (1°)	12.7	60.00'
.53 (17/32)	1.06° (1-1/16°)	13.5	1° 3.75'
.56 (9/16)	1.13° (1-1/8°)	14.3	1° 7.50'
.59 (19/32)	1.19° (1-3/16°)	15.1	1° 11.25'
.62 (5/8)	1.25° (1-1/4°)	15.9	1° 15.00'
.66 (21/32)	1.31° (1-5/16°)	16.7	1° 18.75'
.69 (11/16)	1.38° (1-3/8°)	17.5	1° 22.50'
.72 (23/32)	1.44° (1-7/16°)	18.3	1° 26.50'
.75 (3/4)	1.50° (1-1/2°)	19.0	1° 30.00'

Parts

TRUCK SLEEVE BOARD 88210

Containing our most popular truck sleeves, this board set gives you excellent application coverage, while keeping inventory in check. **Includes display board, hooks and labels.**

BOARD INCLUDES ONE EACH OF THE FOLLOWING:

- 23102, 23104, 23106, 23108, 23109, 23112** Change camber and caster on Ford 4WD trucks with twin traction beam Dana 44 and Dana 50 axles.
- 23132, 23134, 23136, 23138, 23139** Change camber and caster on Ford and Dodge trucks including Ford 4WD F350 Crew Cabs and Dodge 4WD BR2500 and RWD & 4WD BR3500 vans.
- 23182, 23184, 23186, 23188, 23190, 23199** Change camber and caster on twin traction beam Dana 35 suspensions and many other high volume RWD and 4WD Fords.
- 23222, 23224, 23226, 23228, 23229, 23212** Change camber and caster sleeves on 2005 & Up F250 and F350 4WD Ford Super Duty's.
- 24120, 24130, 24180, 24220, 74400, 74500, 74600** Adjustable truck sleeves add versatility to this set, along with our special wrenches that make installation easier.



PASSENGER CAR ASSORTMENT BOARD 88260

This Board Set includes our most popular shims and cam kits for passenger vehicles. This is a "must have" for any shop performing 4 wheel alignments on cars, mini vans and SUVs.

Includes display board along with extra hooks and labels so you can add your own "Most used" SPC Alignment Parts and Tools.

- 66050** **Chrysler/Dodge Camber Bushing & Bushing Press Adapters** - Everything you need, to adjust rear camber on the popular Chrysler LX platform. **2 sets included**
- 66025**
- 66037** **Chrysler LX Camber/Caster Cam** - Adjusts front alignment angles **2 cams included**
- 72055** **Infiniti/Nissan Rear Cam Bolt Kit** - For setting camber and toe on a variety of popular Infinitis and the 350Z. **1 set included**
- 81250, 81260, 81270, 81280, 81290** **EZ Cams XR™** - Camber kits for domestic and imported vehicles with two bolt non-slotted struts. Sizes include 12mm, 14mm, 15mm, 16mm and 17mm. **#81260 - 2 kits included, #81250, #81270, #81280 and #81290 - 1 kit included** Each kit contains two cam bolt assemblies, enough for both sides of the vehicle.
- 84120** **Hyundai/Kia Rear Camber Bolt Kit** - Easy to install camber kits for Sedonas and Entourages. **2 kits included**
- 87365** **Ford, Mercury, Lincoln Front Camber Adjustment Bolt.** **2 kits included.**



LIGHT TRUCK/SUV BOARD 88270

This board set includes the most popular parts for aligning today's trucks and SUVs. Don't be caught without the part that you need. **Includes peg board, hooks and labels.**

- 25435** **Toyota Cam Kit** - Cam./Cas. cams for Tacomas, PreRunners, FJs, and 4Runners. (2)
- 25445** **Toyota Cam Kit** - Cam./Cas. cams for Sequoias and Tundras. (2)
- 26012 & 26014** **Jeep Camber Shims** - 2 each of +.5° and +1.0° to correct camber on WJ, KJ & JK.
- 82380** **Jeep Pinion Angle Adjusters** - For TJ Series Jeeps, Grand Cherokees & Ram Trucks. (1)
- 82385** **Dodge 4x4 Caster Cams** - Camber/Pinion cams for 3/4 and 1 ton solid axle Dodges. (1)
- 82390** **Jeep JK Cams** - Camber/Pinion cams for the popular JK Wrangler. (1)
- 86250** **Ford F150 Camber/Caster Cam Bolt Kit** - Front kit for the 2004 & Up F150s. (2)
- 86325** **GM 1/2 & 3/4 Ton Alignment Pins** - For 2002 & Up C & K 1500, 2500 and 3500s. (1)
- 86375** **GM Front Alignment Kit** - For 2002 - Up C & K 1500, 2500 & 3500s, Express Vans. (2)
- 87385** **Ford F150 Front Camber** - Cam bolt assemblies for 1997 - 03 F150s and F250(LD)s. (1)
- 87420** **GM Rear Cam Nut** - Cams for 2005 & Up Theta Platforms, including Suzuki XL-7s. (2)
- 87500** **Ford Explorer Front Cam/Cas Kit** - For 1995 - 01 Explorers, 1998 - 2011 Rangers. (1)
- 87520** **Nissan Camber/Caster Kit** - For 2004 & Up Titan, and 2005 & Up Pathfinder, Xterra. (2)



Also available - our updated Tool Board Set (Part No. 87910) on page 162 - Set up your alignment shop with the tools you need to get going.



SHIM ASSORTMENT BOARD SET 88700

Includes our popular EZ Shims™ and accessories along with our Toyota Sienna Shims. **Includes display board, hooks and labels.**

- 71621, 71622, 71623** **Toyota Sienna Shims** - Nylon shims for: Camber: ±10°, ±20°, ±30°, ±40° & ±50° and Toe: ±25° & ±50° **1 each size included**
- 71624, 71625**
- 71631, 71632**
- 75200, 75400, 75600** **EZ Shims™** - Adjust Camber and Toe up to ffl.5 on a large variety of FWD vehicles. **2 shims of each size included**
- 10408** **M10 X 1.5 X 40 Bolts** - Use with rear shims. **1 set of 8 bolts included**
- 75910** **EZ Shim Dial Chart** - Makes using the EZ Shim a snap. **1 Dial Chart included**
- 75915** **EZ Shim Cutting Pliers** - Prevent breakage when cutting shims. **1 Cutter included**
- 75920** **EZ Shim Marker** - **1 Marker included**
- 75970** **Shim Spacer Kit** - 2 each of 4 sizes to align caliper to rotor. **1 set included**



Applications
Alignment Parts
Heavy Duty
OE Replacement
Racing/Builders
Tools
Brake and CV
Gear/Index

Parts Get Organized!

BUILD A TOTAL WHEEL ALIGNMENT CUSTOM INVENTORY CONTROL BOARD ANY WAY YOU LIKE IT...

Our complete line of alignment parts may now be displayed in any grouping you would like on a custom inventory control board. The requirements consist of purchasing a minimum of 12 part numbers (excluding SLA shims) of your choice. You select the product, we will package the board, hooks and labels for you to customize your board set. Just copy the form below and mail or fax it to your local distributor, or to Specialty Products for us to forward to your closest distributor. **The board, hooks and labels are *no charge* when 12 different part numbers are purchased.**



DATE _____ PHONE _____ YOUR P.O. NUMBER _____

Bill To: _____

Ship To: _____

CUSTOM INVENTORY CONTROL BOARD NO. 88120 - LAYOUT FORM.

Write our part number in the boxes below and the quantity you would like. Each space can hold up to 3 items. Order up to 20 part numbers OR up to 30 truck sleeve part numbers.

Part No. _____ Qty. _____ <i>(Up to three)</i>	Part No. _____ Qty. _____ <i>(Up to three)</i>	Part No. _____ Qty. _____ <i>(Up to three)</i>	Part No. _____ Qty. _____ <i>(Up to three)</i>	Additional Part No. <i>(Truck Sleeves Only)</i> _____ Qty. _____ <i>(Up to three)</i>
Part No. _____ Qty. _____ <i>(Up to three)</i>	Part No. _____ Qty. _____ <i>(Up to three)</i>	Part No. _____ Qty. _____ <i>(Up to three)</i>	Part No. _____ Qty. _____ <i>(Up to three)</i>	Additional Part No. <i>(Truck Sleeves Only)</i> _____ Qty. _____ <i>(Up to three)</i>
Part No. _____ Qty. _____ <i>(Up to three)</i>	Part No. _____ Qty. _____ <i>(Up to three)</i>	Part No. _____ Qty. _____ <i>(Up to three)</i>	Part No. _____ Qty. _____ <i>(Up to three)</i>	Additional Part No. <i>(Truck Sleeves Only)</i> _____ Qty. _____ <i>(Up to three)</i>
Part No. _____ Qty. _____ <i>(Up to three)</i>	Part No. _____ Qty. _____ <i>(Up to three)</i>	Part No. _____ Qty. _____ <i>(Up to three)</i>	Part No. _____ Qty. _____ <i>(Up to three)</i>	Additional Part No. <i>(Truck Sleeves Only)</i> _____ Qty. _____ <i>(Up to three)</i>
Part No. _____ Qty. _____ <i>(Up to three)</i>	Part No. _____ Qty. _____ <i>(Up to three)</i>	Part No. _____ Qty. _____ <i>(Up to three)</i>	Part No. _____ Qty. _____ <i>(Up to three)</i>	Additional Part No. <i>(Truck Sleeves Only)</i> _____ Qty. _____ <i>(Up to three)</i>
Additional Part No. <i>(Truck Sleeves Only)</i> _____ Qty. _____ <i>(Up to three)</i>	Additional Part No. <i>(Truck Sleeves Only)</i> _____ Qty. _____ <i>(Up to three)</i>	Additional Part No. <i>(Truck Sleeves Only)</i> _____ Qty. _____ <i>(Up to three)</i>	Additional Part No. <i>(Truck Sleeves Only)</i> _____ Qty. _____ <i>(Up to three)</i>	Additional Part No. <i>(Truck Sleeves Only)</i> _____ Qty. _____ <i>(Up to three)</i>

IMPORTANT: YOUR PHONE NUMBER, IN CASE WE HAVE QUESTIONS ABOUT YOUR ORDER:

HOW TO USE THIS ORDER FORM:

- COPY THIS FORM ON YOUR COPY MACHINE.**
- Choose at least 12 parts from any* listed in our current catalog and get the board, hooks & labels **FREE!** Remember - They need to fit on our Custom Control Board.
- Write the part number and quantity needed in the spaces indicated on the board layout.
- Assign a purchase order number to this order, fill in your company name and address(es), then mail or fax it to your distributor or fax to **1-303-772-1918** and Specialty Products will forward it to your closest distributor.
- Product indicated will be shipped with each Custom Inventory Control Board unless requested differently by customer.

* **Some exclusions do occur, please call for more information.**

Board Dimensions: 23-1/2" x 32". May be hung horizontally or vertically.

M10 X 1.5 X 40 SET OF 8 BOLTS

Contains 8 M10 x 1.5 x 40mm allen head rear hub bolts to be used with the rear shims when needed. Use with EZShims (pg 116).



10408

Jeep JK/JL Suspension Arm Series

13410 / 13411

Front Adjustment range:
Caster and Pinion $\pm 3.0^\circ$

Required: 2 per axle

APPLICATIONS

13410

Jeep: 2007 - 2018 Wrangler (JK)

13411

Jeep: 2018 & Up Wrangler (JL)
2020 & Up Gladiator (JT)

13415 / 13416

Front Replacement Part

Required: 2 per axle

APPLICATIONS

13410

Jeep: 2007 - 2018 Wrangler (JK)

13411

Jeep: 2018 & Up Wrangler (JL)
2020 & Up Gladiator (JT)

13421

Rear Adjustment range:
Pinion $\pm 3.0^\circ$

Required: 2 per axle

APPLICATIONS

Jeep: 2007 - 2018 Wrangler (JK)
2018 & Up Wrangler (JL)

13426

Rear Replacement Part

Required: 2 per axle

APPLICATIONS

Jeep: 2007 - 2018 Wrangler (JK)
2018 & Up Wrangler (JL)



SPC knows JK - Look for all of our JK Products:

23510 Pin Joints - page 78

23605 Tie Rod Adjuster Sleeves page 77

26012 Camber Shims - page 83 & 26014

82390 Rear Caster/Pinion Adj. Bolts - page 123

These direct-fit control arms add strength and articulation flexibility to your stock-height or 'lifted' Wrangler. They feature SPC's xAxis™ sealed flex joints to provide bind-free 'twist' between the frame and axle during articulation and OE 'Clevite' bushings for long service life and reduced N.V.H. Main tubes are D.O.M steel to provide strength for large tires and aggressive gearing. Bent arms provide additional clearance for taller/wider tires.

JEEP JK FRONT ADJ. UPPER CONTROL ARM W/XAXIS 13410

JEEP JL FRONT ADJ. UPPER CONTROL ARM W/XAXIS 13411

This direct-fit front upper control arm adds strength, on-car adjustability and articulation flexibility to your stock-height or 'lifted' suspension Wrangler. The dual-threaded adjuster and jam nut makes caster/pinion angle adjustments quick and easy without the need to disconnect the arm or mess with cams and slotted hole knock-outs.



NEW

JEEP JK FRONT LOWER CONTROL ARM W/XAXIS 13415

JEEP JL FRONT LOWER CONTROL ARM W/XAXIS 13416

This direct-fit, stock-length front lower control arm adds strength and articulation flexibility to your stock-height or 'lifted' suspension Wrangler. It features SPC's xAxis™ sealed flex joint and an OE style rubber joint to provide bind-free 'twist' between the frame and axle during off-road articulation.



NEW

JEEP JK/JL REAR ADJ. UPPER CONTROL ARM W/XAXIS 13421

This direct-fit rear upper control arm adds strength, on-car adjustability and articulation flexibility to your stock-height or 'lifted' suspension Wrangler. It features SPC's xAxis™ sealed flex joint mounted in a forged ring at the axle end to provide bind-free 'twist' between the frame and axle during off-road articulation with an OE style rubber joint mounted on the other. The dual-threaded adjuster and jam nuts make rear pinion angle adjustments quick and easy without the need to disconnect the arm.



NEW

JEEP JK/JL REAR LOWER CONTROL ARM W/XAXIS 13426

This direct-fit, stock-length rear lower control arm adds strength and articulation flexibility to your stock-height or 'lifted' suspension Wrangler. It features SPC's xAxis™ sealed flex joint and an OE style rubber joint to provide bind-free 'twist' between the frame and axle during off-road articulation.



NEW

Applications

Alignment Parts

Heavy Duty

OE Replacement

Builders

Tools

Brake and

Index

Parts Sleeve Installation Chart

The illustrations below show where to position the slot in the sleeve to get the amount of camber, caster or both needed. Positions 1, 2, 3 & 4 will change camber/caster the amount stamped on the sleeve. Positions 5, 6, 7 & 8 will change the camber/caster by the following amounts:

FOR SLEEVES:		
23000	23100	23130
23180	23220	23230

DEGREE	CHANGE	DEGREE	CHANGE	DEGREE	CHANGE	DEGREE	CHANGE
1/4 - .25	3/16 (.18)	3/4 - .75	17/32 (.53)	1-1/4 - 1.25	7/8 (.88)	1-3/4 - 1.75	1-7/32 (1.29)
1/2 - .50	11/32 (.35)	1 - 1.0	11/16 (.70)	1-1/2 - 1.5	1-1/16 (1.06)	2 - 2.0	1-13/32 (1.40)

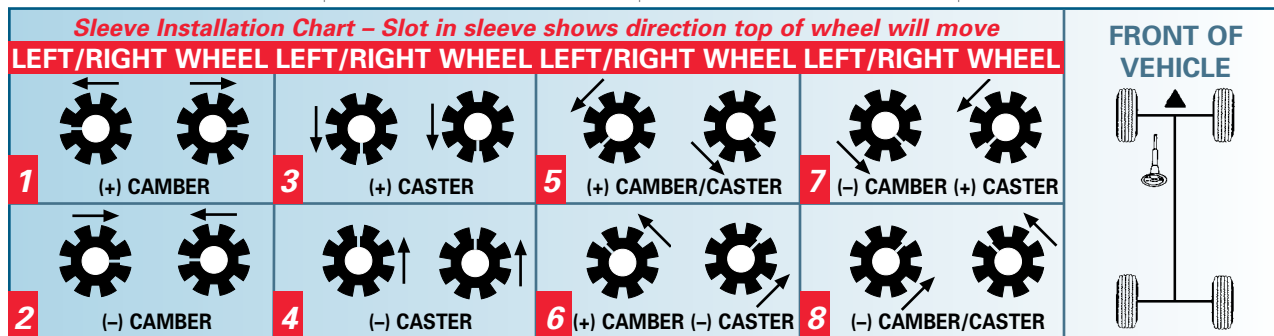

23000 SERIES



4WD BUSHING

This sleeve changes camber and caster on many older model trucks and SUVs with Dana 44 or GMC 10 bolt axles. #4169 spanner socket is required for sleeve removal. Rotate sleeve to fine tune camber/caster adjustment.

Set 23000 contains 1 each: 23002, 23004, 23006, 23008, 23010, 23012

Part No.	Total Change
23002	.25° (1/4")
23004	.50° (1/2")
23006	.75° (3/4")
23008	1.00° (1")
23010	1.25° (1-1/4")
23012	1.50° (1-1/2")

Front Adjustment range:

Camber/Caster $\pm 25^\circ$ to $\pm 1.50^\circ$

Required.: 1 per wheel

APPLICATIONS

Chevrolet/GMC 4WD:

1970 - 87 K10, K15, K20, K25; 1969 - 91 Suburban
1969 - 91 Blazer (K5), Jimmy (K5)
1958 - 87 K30, K35

Dodge 4WD: 1972 - 93 W100, W150, AW150, W200, W250; 1974 - 87 Dodge Ramcharger

Ford 4WD: 1966 - 79 F100, F150; 1973 - 79 F250
1971 - 79 Bronco

International 4WD: 1972 - 75 1/2 & 3/4 ton Pickup
1973 - 80 Scout II

Jeep 4WD: 1974 - 83 Cherokee; 1945 - 86 CJ
1966 - 73 Jeepster, Commando; 1974 - 84 Pickup
1982 - 86 Scrambler; 1974 - 91 Grand Wagoneer

Plymouth 4WD: 1974 - 81 Trailduster

23100 SERIES



4WD CAM/CAS SLEEVES

Change camber, caster, or both on twin traction beam Dana 44s with these sleeves. Simply remove the tire, cotter pin and upper ball joint stud nut and break the taper free between the stud and sleeve. Using a sleeve puller, remove the existing sleeve. Install zero degree sleeve 23109 to determine the change needed, then install the correct sleeve. To split camber and caster adjustment, rotate sleeve 45°.

Set 23100 contains 1 each: 23101, 23102, 23103, 23104, 23105, 23106, 23107, 23108, 23109

Part No.	Total Change	Part No.	Total Change
23101	.25° (1/4")	23107	1.75° (1-3/4")
23102	.50° (1/2")	23108	2.00° (2")
23103	.75° (3/4")	23109	0.00° (0")
23104	1.00° (1")	23111	2.25° (2-1/4")
23105	1.25° (1-1/4")	23112	2.50° (2-1/2")
23106	1.50° (1-1/2")	23113	2.75° (2-3/4")

Front Adjustment range:

Camber/Caster $\pm 25^\circ$ to $\pm 2.75^\circ$

Required: 1 per wheel

APPLICATIONS

Ford 4WD:

1980 - 96 Bronco - Full Size
1980 - 96 F150
1980 - 98 F250, F350

Adjustable Sleeve available,
Part No. 24130 - page 79

77880 - Puller, pg 171
88830 - Puller, pg 175

We have adjustable sleeves for most sleeve applications.

We have discontinued our 23120 and 23160 series of fixed change sleeves, but still have these applications covered with our 24120 and 24160 adjustable sleeves (page 79). The adjustable sleeves can adjust camber and caster in a large variety of combinations.

Front Adjustment range:
Camber/Caster $\pm 25^\circ$ to $\pm 2.00^\circ$

Required: 1 per wheel

APPLICATIONS

Dodge RWD:

1994 - 99 3500 Ram w/Mono Beam

Dodge 4WD:

1994 - 99 2500HD, 3500 Ram

Ford RWD/4WD:

1999 - 04 F450, F550

1999 - 04 F250, F350

Solid Axles/Leaf Springs

Ford 4WD:

2000 - 05 Excursion

1992 - 98 F350 Crew Cab



77880 - Puller, pg 171
87175 - Socket, pg 173
88830 - Puller, pg 175

4WD & RWD SLEEVES

23130 SERIES

Change camber, caster, or both at the same time with these sleeves. Simply remove the tire, cotter pin and upper ball joint stud nut and break the taper free between the stud and sleeve. Using a sleeve puller, remove the existing sleeve. *Install zero degree sleeve 23139 to determine the change needed, then install the correct sleeve.* To split camber and caster adjustment, rotate sleeve 45° .



Set 23130 contains 1 each: 23131, 23132, 23133, 23134, 23135, 23136, 23137, 23138, 23139

Part No.	Total Change	Part No.	Total Change
23131	.25° (1/4°)	23136	1.50° (1-1/2°)
23132	.50° (1/2°)	23137	1.75° (1-3/4°)
23133	.75° (3/4°)	23138	2.00° (2°)
23134	1.00° (1°)	23139	0.00° (0°)
23135	1.25° (1-1/4°)		

**Adjustable Sleeve available,
Part No. 24130 - page 79**

**Sleeve Installation Chart -
See page 74**

Front Adjustment range:
Camber/Caster $\pm 25^\circ$ to $\pm 3.50^\circ$

Required: 1 per wheel

APPLICATIONS

Ford RWD:

1989 - 90 Bronco II

1992 & Up E150, E250, E350, E450

2000 - 05 Excursion; 1987 - 96 F150

1998 & Up F250, F350 Twin I-Beam

1987 - 98 F250, F350

Ford 4WD:

1990 - 90 Bronco II (Late 90-Dana 35)

Ford RWD/4WD:

1991 - 94 Explorer; 1990 - 97 Ranger

Mazda RWD/4WD:

1994 - 97 B-Series Pickup

1991 - 94 Navajo



77880 - Puller, pg 171
87175 - Socket, pg 173
88830 - Puller, pg 175



CAMBER/CASTER SLEEVES

These popular sleeves are widely used to adjust caster and/ or camber on many Ford and Mazda RWD & 4WD trucks. To install, simply loosen and remove upper ball joint pinch bolt. Remove top snap ring if one is present. Use 77880 or 88830 sleeve puller to remove the existing sleeve. To split camber and caster adjustment, rotate sleeve 45° . *Save time during alignment, use 23199 zero degree sleeve to determine initial readings, then install correct sleeve.*

Note: Sleeves adjust to a smaller degree on Ford and Mazda 4WD light trucks/SUVs.

Set 23180 contains 1 each: 23181, 23182, 23183, 23184, 23185, 23186, 23187, 23188, 23199

23180 SERIES

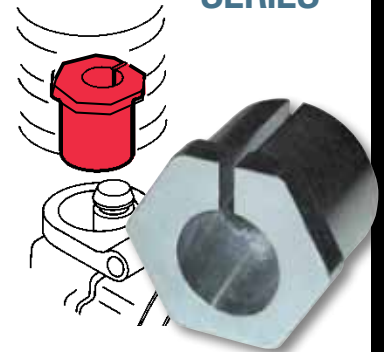

Series	RWD Adjustments Total change	4WD Adjustments Total change	Series	RWD Adjustments Total change	4WD Adjustments Total change
23181	.25° (1/4°)	.20°	23188	2.00° (2°)	1.40°
23182	.50° (1/2°)	.40°	23189	2.25° (2-1/4°)	1.60°
23183	.75° (3/4°)	.60°	23190	2.50° (2-1/2°)	1.80°
23184	1.00° (1°)	.75°	23191	2.75° (2-3/4°)	2.00°
23185	1.25° (1-1/4°)	.90°	23192	3.00° (3°)	2.25°
23186	1.50° (1-1/2°)	1.10°	23193	3.25° (3-1/4°)	2.50°
23187	1.75° (1-3/4°)	1.25°	23194	3.50° (3-1/2°)	2.75°
			23199	0.00° (0°)	

**Adjustable Sleeve available,
Part No. 24180 - page 79**

**Sleeve Installation Chart -
See page 74**

Stabilizer Heights – NARROW UNITS for small diameter (.58") coil springs.

STABILIZER NO.	HEIGHT ("A")
24640	5/8"
24690	7/8"
24750	1-1/4"
24751	1-1/4"
	Short Nose
24740	1-1/4"
	Small Radius
24790	1-1/2"

Stabilizer Heights – REGULAR UNITS for average diameter (.63") coil springs.

STABILIZER NO.	HEIGHT ("A")
24650	5/8"
24700	7/8"
24701	7/8"
	Short Nose
24960	1"
24970	1-1/4"
24800	1-1/2"
24850	1-3/4"
24900	2"
24950	2-1/2"

COIL SPRING STABILIZERS

Proper alignment is impossible unless coil springs are operating at originally designed height.

Two stabilizers are recommended per coil spring. If front stabilizers are rubbing against the spring well housing the stabilizer must be installed from the inside of the coil springs. **Four per pack.**

Due to the curvature of some springs, two sizes may be required for the same spring (Example: 24700 on inside of coil, 24750 on outside). When measuring and installing stabilizers, one space should be skipped between coils.

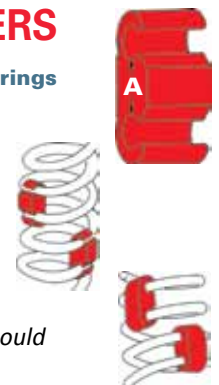

Parts

23220 SERIES



Adjustable Sleeve available, Part No. 24220 - page 79

FORD F250, F350 SLEEVES

Ford changed the axle design in 2005 on their Heavy Duty trucks. These sleeves correct camber and caster on these F250 and F350 Super Duty trucks. Use the **23229** zero degree sleeve to determine the amount of change needed.

Set **23220** contains 1 each: **23221, 23222, 23223, 23224, 23225, 23226, 23227, 23228, 23229**

Part No.	Total Change	Part No.	Total Change
23221	.25° (1/4")	23227	1.75° (1-3/4")
23222	.50° (1/2")	23228	2.00° (2")
23223	.75° (3/4")	23211	2.25° (2-1/4")
23224	1.00° (1")	23212	2.50° (2-1/2")
23225	1.25° (1-1/4")	23229	0.00° (0°)
23226	1.50° (1-1/2")		

Sleeve Installation Chart - pg 74

Front Adjustment range:
Camber/Caster $\pm 0.25^\circ$ to $\pm 2.50^\circ$

Required: 1 per wheel

APPLICATIONS

Ford RWD/4WD:
2005 & Up F250, F350
Solid Axle,
Coil Spring
2005 & Up F450
With 8 Lug Axles



Applications

Alignment Parts

Heavy Duty

OE Replacement

Racing/Builders

Tools

Brake and CV

Gear/Intr.

23230 SERIES



Adjustable Sleeve available, Part No. 24230 - page 79

1-1/2 & 2 TON SLEEVES

These truck sleeves will correct alignment problems on F450 and F550 Super Duty Trucks with Dana Super 60 solid axles. To split camber and caster adjustment, rotate sleeve 45° Use the **23239** zero degree sleeve to determine the amount of change needed.

Set **23230** contains 1 each: **23231, 23232, 23233, 23234, 23235, 23236, 23237, 23238, 23239**

Part No.	Total Change	Part No.	Total Change
23231	.25° (1/4")	23236	1.50° (1-1/2")
23232	.50° (1/2")	23237	1.75° (1-3/4")
23233	.75° (3/4")	23238	2.00° (2")
23234	1.00° (1")	23239	0.00° (0°)
23235	1.25° (1-1/4")		

Front Adjustment range:
Camber/Caster $\pm 0.25^\circ$ to $\pm 2.00^\circ$

Required: 1 per wheel

APPLICATIONS

Chevy/GMC 4WD:
2003 - 09 Kodiak/Topkick K4500,
Kodiak/Topkick K5500
Ford RWD/4WD:
2005 & Up F450,
F550 With 10 Lug
Axles



Sleeve Installation Chart - pg 74

23268 23269



FIXED CHANGE FORD SUPER DUTY SLEEVES

These sleeves have a fixed positive camber and caster change and are designed specifically to align trucks that have been lifted or to provide more caster change than our 23220 series.

For maximum drivability and to compensate for road crown, use a 23268 on the driver's side and a 23269 on the passenger's side.

Front Adjustment range (Fixed):
23268 Camber +.50 Caster +2.3
23269 Camber +.30 Caster +2.6

Required: 1 per wheel

APPLICATIONS

Ford RWD/4WD:
2005 & Up F250, F350 Solid Axle,
Coil Spring
2005 & Up F450 With 8 Lug Axles



23400 SERIES

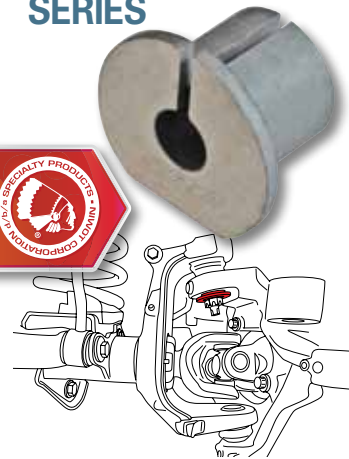

JEEP WRANGLER SLEEVES

Fix front camber issues on your Jeep Wrangler (JL) by replacing the camber sleeve that links the upper ball joint to the knuckle. Simply determine what degree offset sleeve is already in the knuckle and replace it with a new offset. Most JL's are coming off the line with a +.25° sleeve, which means, for example, if you need .5° more camber and have a factory +.25° sleeve you will want to use the +.75° sleeve (p/n 23403) to get in spec. If you work on a lot of Jeeps or are not sure what you will need, get the six (6) piece set, which includes one of each sleeve. SPC's camber sleeves feature a hex chromate-free finish certified to a 700 hour salt spray test.

Use the **23409** zero degree sleeve to determine the amount of change needed.

Set **23400** contains 1 each: **23401, 23402, 23403, 23404, 23405, 23409**

Part No.	Total Change	Part No.	Total Change	Part No.	Total Change
23401	+.25° (1/4")	23403	+.75° (3/4")	23405	+1.25° (1-3/4")
23402	+.50° (1/2")	23404	+1.00° (1")	23409	0.00° (0°)

Front Adjustment range:
Camber +0.25° to +1.25°

Required: 1 per wheel

APPLICATIONS

Jeep: 2018 & Up Wrangler (JL)
2020 & Up Gladiator (JT)

Check out our Jeep JL Suspension Arm Series on page 73

Front Adjustment range:
Camber $\pm 1.25^\circ$

For lifted or raised suspensions only

Required: 1 per wheel

APPLICATIONS

Jeep: 2006 -10 Commander
2005 - 10 Grand Cherokee



72509 - Ball joint press, pg 169

JEEP ADJ. BALL JOINT

23420

Add camber adjustment to your lifted Jeep Grand Cherokee or Commander with the highest quality ball joint on the market! This joint is **specifically designed to work with lifted or raised suspensions** and features:

- Induction hardened and oversized 18mm stud for extreme strength and high durability
- 700 hour long-life salt spray resistant coating
- Hybrid 2-piece race and internal spring compensate for wear over time
- Fully sealed greasable design
- 80° of articulation to maximize travel without binding vs 66° on the factory joint

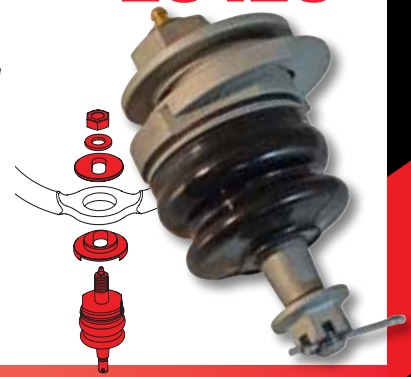

Rear Adjustment range:
Camber $\pm 3.00^\circ$

Required: 1 per wheel



APPLICATIONS

Acura: 2014 & Up MDX
Honda: 2016 & Up Pilot
2017 & Up Ridgeline

ACURA AND HONDA REAR ADJ. BALL JOINT

23450

Use this sliding ball joint to adjust camber on the rear of the Acura MDX along with the Honda Pilot and Ridgeline for improved handling and tire wear. The OE quality ball joint is easily installed and corrects camber angles $\pm 3^\circ$.



72509 - Ball joint press, pg 169

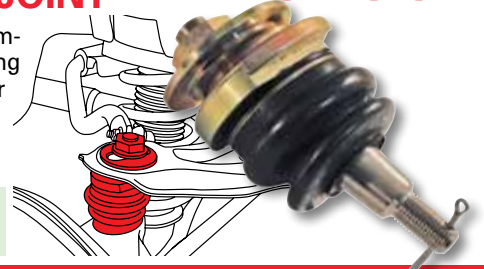

Dodge/Jeep Pin Joints #23510 & #23710 - Next Page

Front Replacement Part

Required: 1 per axle

APPLICATIONS

Chrysler: 1999 - 04 300M
1998 - 04 Concorde
1998 - 01 LHS
Dodge: 1998 - 04 Intrepid

LH REPLACEMENT SLEEVE

23600

This adjustable sleeve replaces the knurled tie rod adjusting sleeve on 1998 - 04 Chrysler LH bodies. Recommended when the existing sleeve has been damaged or if the tie rod end is being replaced so adjustments can be made easily.



55600, 55700 - LH Toe Tools, pg 167

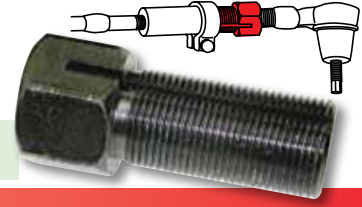

Front Replacement Part

Required: 1 per axle

APPLICATIONS

23605
Jeep: 2007 - 18 Wrangler (JK)

23610 Manufactured before 11/4/13 Ram: 2014 2500 2013 - 14 3500	23615 Manufactured after 11/4/13 Ram 2014 & Up 2500 2013 & Up 3500
--	---



TIE ROD ADJUSTER SLEEVES

23605

23610

23615

These adjustable hex shaped sleeves replace the round tie rod sleeve to assure ease of adjustment without slippage. Recommended when the existing sleeve is damaged or when replacing a tie rod end for easy adjustment.

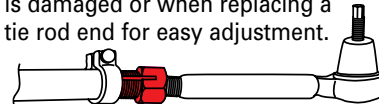

Front Adjustment range:
Camber $\pm 1.00^\circ$ Caster 1.50°

Required: 1 kit per wheel

APPLICATIONS

23755 2 cam/bolt sets - 1 side
Dodge 4WD: 2002 - 05 1500 Ram

23765 2 cam/bolt sets - 1 side
Dodge RWD: 2002 - 05 1500 Ram

4WD & RWD DODGE TRUCK CAMBER/CASTER KITS (PR)

23755

23765

These heavy duty bolts and brackets replace the upper control arm

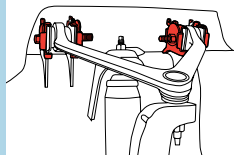

mounting bolts giving you both camber and caster adjustment. Kit includes 2 cam and bolt sets to cover one side of the vehicle.



Parts

Dodge/Jeep Pin Joints

These offset pin joints replace the upper pin joints on many models of Dodge and Ram Trucks. They come in 1/2° increments and provide for independent wheel caster and/or camber changes. To more easily remove and install these sleeves use the recommended installation sleeves along with a ball joint press.

23500 Series

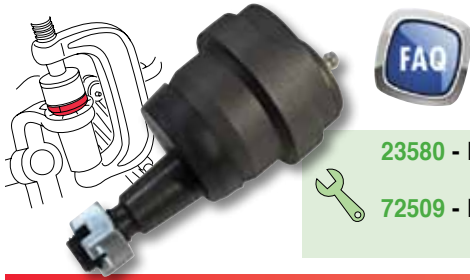

- 23580** - Ball joint press sleeves, pg 163
72509 - Ball joint press, pg 169

Front Adjustment range:

- 23510** Cam/Cas ±.50° **23520** Cam/Cas ±1.00°
23530 Cam/Cas ±1.50° **23540** Cam/Cas ±2.00°

Required: 1 per wheel

APPLICATIONS

- Dodge 4WD:** 1994 - 01 1500 Ram; 1994 - 99 2500 Ram
Jeep 1984 - 01 Cherokee; 1986 - 92 Comanche
RWD/4WD: 1993 - 04 Grand Cherokee
 1984 - 90 Wagoneer; 1987 - 18 Wrangler

23700 Series

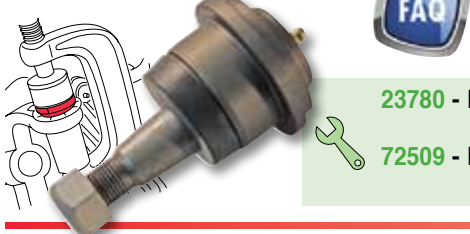

- 23780** - Ball joint press sleeves, pg 163
72509 - Ball joint press, pg 169

Front Adjustment range:

- 23710** Cam/Cas ±.50° **23720** Cam/Cas ±1.00°
23730 Cam/Cas ±1.50°

Required: 1 per wheel

APPLICATIONS

- Dodge 4WD:** 2000 - 02 2500 Ram, 3500 Ram
Dodge RWD: 2000 - 02 3500 Ram w/monobeam

23800 Series

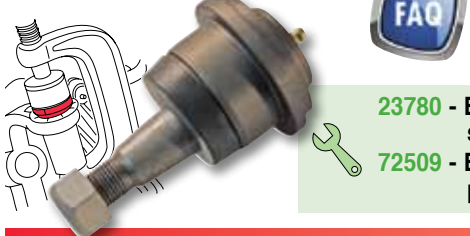

- 23780** - Ball joint press sleeves, pg 163
72509 - Ball joint press, pg 169
- * 23800 is an OE Replacement Ball Joint - no camber/caster change*

Front Adjustment range:

- 23800*** Cam/Cas 0.0° **23810** Cam/Cas ±.50°
23820 Cam/Cas ±1.0° **23830** Cam/Cas ±1.50°

Required: 1 per wheel

APPLICATIONS

- Dodge/Ram RWD:** 2003 & Up 3500 Ram w/mono beam
Dodge/Ram 4WD: 2006 - 08 1500 Ram Mega Cab
 2003 & Up 2500, 3500 Ram

23850 Series

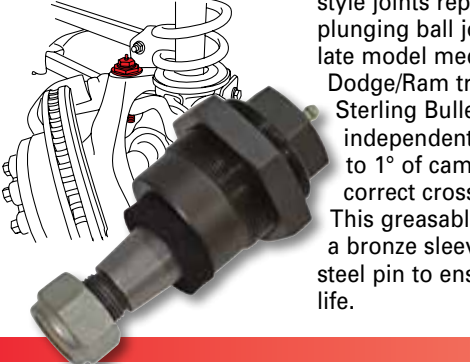

These heavy duty "King Pin" style joints replace the original plunging ball joint design on late model medium duty Dodge/Ram trucks and Sterling Bullets. They provide independent adjustment up to 1° of camber, and will correct cross camber issues. This greasable pin joint uses a bronze sleeve and hardened steel pin to ensure long service life.

Front Adjustment range:

- 23850*** Camber 0.0° **23852** Camber ±.50°
23854 Camber ±1.0°

Required: 1 per wheel

APPLICATIONS

- Dodge/Ram RWD/4WD:** 2008 & Up 4500, 5500
Sterling Bullet RWD/4WD: 2008 - 10 45, 55

** 23850 is an OE Replacement Ball Joint - no camber/caster change*

- 88360** - Pin Adjusting Wrench, pg 175

23940



DODGE/RAM 1500 ADJUSTABLE BALL JOINT

Lifted or lowered, factory cams don't give enough adjustment range on the Dodge/Ram 1500 series of trucks. Gain 2.25° of camber or caster with these offset ball joints. Simply replace the ball joint in the stock upper control arm to get ±2.25° caster, camber, or a split and then dial in final adjustments with the factory cams. Bring ride quality and tire wear back into the green for your customer.

Front Adjustment range:

- Camber ±2.25°/Caster ±2.25°

Required: 1 per wheel

APPLICATIONS

- Dodge/Ram RWD/4WD:** 2006 & Up 1500 Ram (Exc. Mega Cab)

- 72509** - Ball Joint Press, pg 169

Parts

Adjustable Sleeves



Inventory getting out of hand? Just need to fill in a few odd sizes? An Adjustable Sleeve may be just what you need. These sleeves can adjust camber and/or caster in a large variety of combinations. **A great solution for saving money and keeping sales.**

Replaces up to 5 stock sleeves.
Minimum Adjustment $\pm 1.00^\circ$

Front Adjustment range:
Camber/Caster $\pm 1.00^\circ$ to $\pm 2.75^\circ$
Required: 1 per wheel



74500 - Adjustable Sleeve Wrench, pg 170

APPLICATIONS

Ford 4WD: 1983 - 89 Bronco II; 1983 - 89 Ranger
Early 1990 Bronco II (Dana 28)



Replaces up to 21 stock sleeves.
Minimum Adjustment $\pm .75$

Front Adjustment range:
Camber/Caster $\pm .75^\circ$ to $\pm 2.75^\circ$
Required: 1 per wheel

APPLICATIONS



74500 - Adjustable Sleeve Wrench, pg 170

Dodge RWD: 1994 - 99 3500 Ram w/Mono Beam
Dodge 4WD: 1994 - 99 2500HD, 3500 Ram
Ford RWD/4WD: 1999 - 04 F450, F550
Ford 4WD: 1999 - 04 F250, F350 Solid Axles/Leaf Springs
1980 - 96 Bronco - Full Size; 1980 - 96 F150
1980 - 98 F250, F350; 2000 - 05 Excursion
1992 - 98 F350 Crew Cab



We have Fixed Sleeves for these Apps, Part Nos. 23100 - page 74 and 23130 - page 75

Replaces up to 8 stock sleeves.

Front Adjustment range:
Camber 0.0° to $\pm 2.25^\circ$
Required: 1 per wheel



74400 - Adjustable Sleeve Wrench, pg 170

APPLICATIONS

Ford RWD: 1984 - 88 Bronco II; 1982 - 86 F150
1983 - 88 Ranger; 1980 - 83 F100

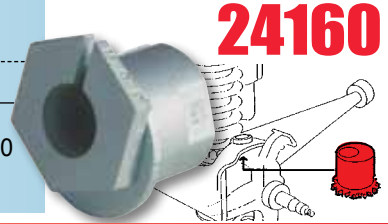

Replaces up to 9 stock sleeves.
Minimum Adjustment $\pm .50^\circ$

Front Adjustment range:
Camber/Caster $\pm .50^\circ$ to $\pm 2.25^\circ$
Required: 1 per wheel

APPLICATIONS



74400 - Adj. Sleeve Wrench, pg 170
74500 - Adj. Sleeve Wrench, pg 170

Ford RWD: 1989 - 90 Bronco II
1992 & Up E150, E250, E350, E450
2000 - 05 Excursion; 1987 - 96 F150
1998 & Up F250, F350 Twin I-Beam
1987 - 98 F250, F350
Ford 4WD: 1990 - 90 Bronco II (Late 90-Dana 35)
Ford RWD/4WD: 1991 - 94 Explorer
1990 - 97 Ranger
Mazda RWD/4WD: 1994 - 97 B-Series Pickup
1991 - 94 Navajo

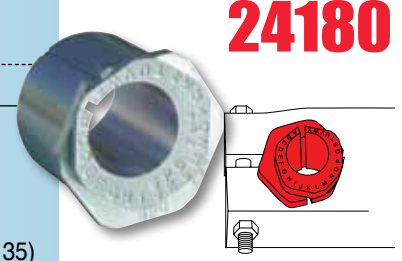

We have Fixed Sleeves for these Apps, Part No. 23180 - page 75

Replaces up to 11 stock sleeves.

Front Adjustment range:
Camber/Caster $\pm 2.50^\circ$
Required: 1 per wheel

APPLICATIONS



74600 - Adjustable Sleeve Wrench, pg 170

Ford RWD/4WD:
2005 & Up F250, F350 Solid Axle, Coil Spring
2005 & Up F450 With 8 Lug Axles



We have Fixed Sleeves for these Apps, Part No. 23220 - page 76

Replaces up to 10 stock sleeves.

Front Adjustment range:
Camber/Caster $\pm 2.75^\circ$
Required: 1 per wheel

APPLICATIONS



74600 - Adjustable Sleeve Wrench, pg 170

Chevy/GMC 4WD: 2003 - 09
Kodiak/Topkick K4500, Kodiak/Topkick K5500
Ford RWD/4WD:
2005 & Up F450, F550 With 10 Lug Axles



We have Fixed Sleeves for these Apps, Part No. 23230 - page 76

Parts

23960

GM ADJ. BALL JOINT

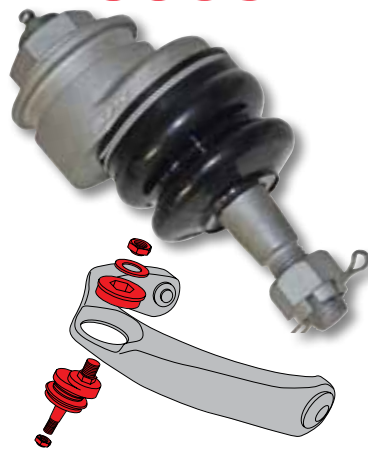

These heavy duty offset ball joints have a built in 3 degree offset which can be clocked to change camber, caster, or both. They are ideal for vehicles which cannot be aligned properly with the factory cam bolts due to installation of a lift or leveling kit. As an additional benefit, they also raise the outer end of the upper control arm, which increases clearance between the arm and the droop travel stops on the frame. This restores droop travel on trucks with leveling kits, and eliminates noise, vibration and harshness caused by arm to frame contact.

Note: Due to strength limitations of the factory upper control arm, this ball joint should not be used on trucks with tires larger than 33" unless

a "tall knuckle" lift kit is installed.

Front Adjustment range:
Camber $\pm 3.00^\circ$ /Caster $\pm 3.00^\circ$

Required: 1 per wheel

APPLICATIONS

Chevy/GMC RWD/4WD:
(With 8 Lug Wheels)

- 2001 - 06 1500HD Crew Cab
- 1999 - 10 2500, 3500 Silverado, Sierra
- 2002 - 06 Avalanche 2500
- 2000 - 13 Suburban 2500
- 2000 - 14 Yukon 2500

Hummer 4WD:

- 2002 - 09 H2



72509 - Ball Joint Press, pg 169



25380

RAV4 CAMBER/TOE CAM BOLT

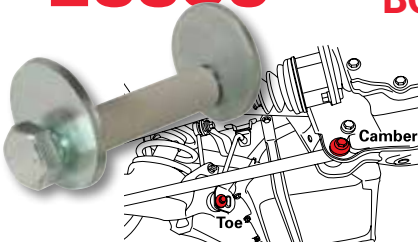

Replace your OE rear camber or toe adjuster with this replacement cam bolt. OE cam bolts are frequently seized and can't be adjusted. Remove the corroded bolt assembly and replace it with SPC's cam bolt to restore the factory $\pm 1.5^\circ$ camber or toe change. This bolt features a plastic sleeve to eliminate future corrosion.

Rear Adjustment range:
Camber $\pm 1.50^\circ$ / Toe $\pm 1.50^\circ$

Required: 1 per wheel/
per angle changed

APPLICATIONS

Toyota: 2001 - 05 RAV4

25425

25430

25435

25440

25445

25450

TOYOTA CAM BOLT KIT (PR)

This cam bolt kit is a replacement kit for the OE adjusters. The OE bolts on Toyota trucks and SUVs are frequently "frozen" and will not allow for adjustment. Remove the frozen bolt assembly and replace it with an SPC cam kit to get up to $\pm 1.5^\circ$ camber and caster change. OE adjuster assemblies that are corroded may require SPC's press tool 40915 for removal, making the job quick and easy.

Front Adjustment range: Camber/Caster $\pm 1.50^\circ$

Required: 1 per wheel

25425 APPLICATIONS

Note: Plastic Sleeves not necessary with this kit.

Toyota 4WD: 1986 - 95 4Runner; 1995 Tacoma
1986 - 94 Pickup; 1993 - 98 T100

25430 APPLICATIONS

Toyota RWD: 1998 - 04 Tacoma w/6 lug axles
Toyota 4WD: 1996 - 04 Tacoma
Toyota RWD/4WD: 1996 - 02 4-Runner

25435 APPLICATIONS

Lexus 4WD: 2003 - 09 GX
Toyota RWD: 2005 - 15 Tacoma w/6 lug axles
Toyota 4WD: 2005 - 15 Tacoma
Toyota RWD/4WD: 2007 - 09 FJ Cruiser
2003 - 09 4Runner

25440 APPLICATIONS

Lexus 4WD: 2010 & Up GX
Toyota RWD/4WD: 2010 - 14 FJ Cruiser
2016 & Up Tacoma w/6 lug axles
2010 & Up 4Runner

25445 APPLICATIONS

Toyota RWD/4WD: 2001 - 07 Sequoia; 1999 - 06 Tundra

25450 APPLICATIONS

Lexus RWD/4WD: 2008 & Up LX570
Toyota RWD/4WD: 2008 & Up Land Crusier 200 Series
2008 & Up Sequoia; 2007 & Up Tundra



40915 - Cam Extractor, pg 165

SPC Performance's Builder Series

SPC Performance has an extensive line of high quality suspension/chassis components for builders. See pages 158-160 for more.



Applications

Alignment Parts

Heavy Duty

OE Replacement

Racing/Builders

Tools

Brake and CV

Gear/Index

TOYOTA FRONT UPPER ARMS (PR)

SPC Adjustable Front Upper Control Arms are the industry standard in off-road and racing applications. These arms use a patented design to adjust camber and caster. When you lift or level your truck you can dramatically change the alignment angles. SPC arms will get you back in spec and give you added adjustments to maximize your suspension set-up.

- **Get more droop travel:** Don't let OE ball joints or mono-ball articulation limit your travel. SPC joints are oversized and provide 80° of travel.
- **Get your drivability and tracking back:** Your truck may have started to 'wander' after you lifted it. That is because you lost caster. Install SPC arms and get your 'drivability' back by putting your alignment in specification.
- **Get your tire where you want it in the wheel well:** Are your oversized tires rubbing the fenders or frame rails? SPC Adjustable Arms, in combination with OE adjustments on the lower arm, allow you to dial in alignment specs at the same time that you move the tire forward/outward in the wheel well by up to 1".

Isolated xAxis™ Sealed Flex Joint Bushings

- Booted to keep contaminants out
- Free pivoting to eliminate binding
- Bonded Rubber Sleeve To minimize Noise, Vibration, and Harshness (NVH)

Fully Forged Arm

- Maximum strength
- Maximum clearance
- +2 Degrees of Caster built-in

Premium Greaseable Ball Joint

- 80° of articulation – more than any other ball joint
- 25% larger stud cross section vs OE
- Greaseable with sealed boot

Designed, engineered, tested, and assembled in Colorado, SPC has stepped it up again.

- Strongest arm available
- Most articulation of any arm, period
- The only booted adjustable ball joint on the market
- Maintenance free pivoting bushing

25455
25460
25465
25470
25480
25485
25490

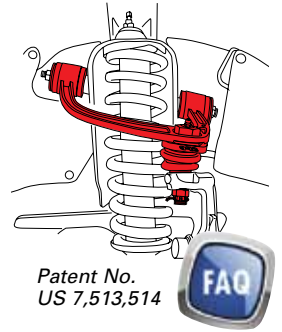

Front Adjustment range: Camber $\pm 2.00^\circ$ Caster 0.0° to $+4.00^\circ$
 Required: 1 per axle

25455 APPLICATIONS

(Note: Caster Range -1.0° to $+3.0^\circ$)
Lexus 4WD: 1998 - 07 LX470
Toyota 4WD: 1998 - 07 Land Crusier 100 Series

25460 APPLICATIONS

Toyota RWD: 1998 - 04 Tacoma w/6 lug axles
Toyota 4WD: 1995 - 04 Tacoma
Toyota RWD/4WD: 1996 - 02 4-Runner

25465 APPLICATIONS

Lexus 4WD: 2008 & Up LX 570
Toyota 4WD: 2008 & Up Land Crusier 200 Series

25470 APPLICATIONS

Toyota RWD: 2005 & Up Tacoma w/6 lug axles
Toyota 4WD: 2005 & Up Tacoma

25480 APPLICATIONS

Lexus 4WD: 2003 & Up GX
Toyota RWD/4WD: 2007 - 14 FJ Cruiser
 2003 & Up 4Runner

25485 APPLICATIONS

Toyota RWD/4WD: 2001 - 07 Sequoia
 1999 - 06 Tundra

25490 APPLICATIONS

Toyota RWD/4WD: 2008 & Up Sequoia
 2007 & Up Tundra

	SPC	OE	Monoball
Articulation & Stud Cross Section	80°	68°	68°
Sealed	✓	✓	✗
Greaseable	✓	✗	✗

REPLACEMENT AND REBUILD KITS AVAILABLE
 SPC has replacement ball joint and bushing kits available for these arms.

Parts

25540

NISSAN FRONT UPPER ADJ. ARMS (PR)

Lifted Nissans often run out of factory alignment adjustment when lift kits are installed. Additionally, the OE upper control arm can contact the spring bucket, limiting droop travel and causing unwanted noise, vibration and harshness. These heavy duty replacement arms feature drawn over mandrel (DOM) tubing construction and use our patented adjustable greaseable ball joint (see below) and xAxis™ sealed flex joints, allowing for greatly increased droop travel and easy alignment.

Front Adjustment range:

Camber $\pm 2.00^\circ$

Caster -1.0° to $+3.00^\circ$

Required: 1 per axle



APPLICATIONS

Nissan: 2005 & Up Frontier
2005 - 12 Pathfinder
2005 - 15 Xterra

Suzuki: 2009 - 12 Equator

Patent No. US 7,513,514

Need new bolts? Order #21035 for two replacement bolts - page 152.

Applications
Alignment Parts

25560

TITAN FRONT UPPER ADJ. ARMS (PR)

Restore lost caster, camber and droop travel on your lifted Nissan Titan and Armada to get your drivability back with these adjustable front upper control arms. Use them in combination with Titan OE lowers on Xterras and Pathfinders for a wider stance. This pair of arms feature:

- A patented adjustable ball joint design to dial in caster and camber $\pm 3.0^\circ$
- Fully forged steel construction for maximum strength
- Arm geometry that clears spring bucket for increased droop travel
- Upgraded greaseable ball joints
- SpecRide™ bushings with free pivot for extended travel while maintaining factory standards for noise, vibration, and harshness (NVH)

Front Adjustment range:

Camber $\pm 3.00^\circ$ Caster $\pm 3.00^\circ$

Required: 1 per axle

APPLICATIONS

Nissan: 2004 - 15 Armada
2004 & Up Titan
(Except XD)



Patent No. US 7,513,514

Heavy Duty

OE Replacement

Racing/Builders

25670 25680

FORD FRONT UPPER ADJ. ARMS (PR)

Improve droop travel, drivability and tire wear as well as adjusting tire position in your wheel well with SPC's adjustable front upper control arms. Featuring an upgraded greaseable ball joint and rubber isolated xAxis™ bushings, this arm is designed to correct alignment angles on standard height vehicles as well as lifted and lowered vehicles while maintaining factory ride quality. SPC's fully forged steel design provides the strength and durability needed for the most demanding environments. These remove and replace arms are sold in pairs.

adjustable front upper control arms. Featuring an upgraded greaseable ball joint and rubber isolated xAxis™ bushings, this arm is designed to correct alignment angles on standard height vehicles as well as lifted and lowered vehicles while maintaining factory ride quality. SPC's fully forged steel design provides the strength and durability needed for the most demanding environments. These remove and replace arms are sold in pairs.

■ **Get more droop travel:** Don't let OE ball joints or mono-ball articulation limit your travel. SPC joints are oversized and provide 80° of travel.

■ **Get your drivability and tracking back:** Your truck may have started to 'wander' after you lifted it. That is because you lost caster. Install SPC arms and get your 'drivability' back by putting your alignment in specification.

■ **Get your tire where you want it in the wheel well:** Are your oversized tires rubbing the fenders or frame rails? SPC Adjustable Arms, in combination with OE adjustments on the lower arm, allow you to dial in alignment specs at the same time that you move the tire forward/outward in the wheel well by up to 1".

Isolated xAxis™ Sealed Flex Joint Bushings

- Booted to keep contaminants out
- Free pivoting to eliminate binding
- Bonded Rubber Sleeve
- To minimize Noise, Vibration, and Harshness (NVH)

Designed, engineered, tested, and assembled in Colorado, SPC has stepped it up again.

- Strongest arm available
- Most articulation of any arm, period
- The only booted adjustable ball joint on the market
- Maintenance free pivoting bushing

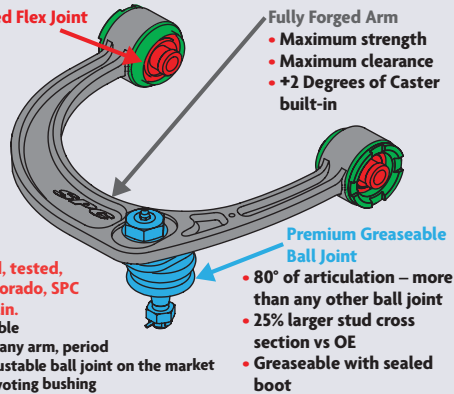

Front Adjustment range:

Camber $\pm 2.00^\circ$

Caster -1.0° to $+3.00^\circ$

Required: 1 per axle

25670 APPLICATIONS

Ford: 2019 & Up Ranger

25680 APPLICATIONS

Ford: 2004 & Up F150
(Except Raptor)

Lincoln: 2006 - 08
Mark LT

SPC #86252 upgraded bolts and adjustment plates lock in your alignment and prevent bolt slip on the lower control arm. See page 127.

Patent No. US 7,513,514

Brake and CV

Gear/Index



25670



25680

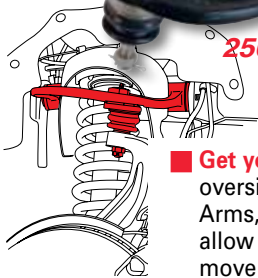

Front Adjustment range:

26012 +.50° Camber **26014** +1.0° Camber

Required: 1 per wheel

APPLICATIONS

- Ford 4WD:** 2001 - 03 Explorer
2001 - 05 Explorer Sport Trac; 2003 - 11 Ranger
- Jeep RWD:** 1994 - 01 Cherokee XJ
- Jeep 4WD:** 1984 - 01 Cherokee XJ
1993 - 10 Grand Cherokee ZJ/WJ
1987 - 06 Wrangler YJ/TJ; 1984 - 90 Wagoneer XJ
- Jeep FWD/4WD:** 2002 - 07 Liberty KJ
- Jeep RWD/4WD:** 1986 - 92 Comanche MJ
2007 - 18 Wrangler JK; 2006 - 10 Commander XK

CAMBER SHIMS

Change camber +0.5° or +1.0° on many popular Jeep and Ford models by installing this shim between the hub and steering knuckle. A caliper shim is also included. These durable high-strength nylon shims provide a faster option for correcting negative camber issues.

26012 26014

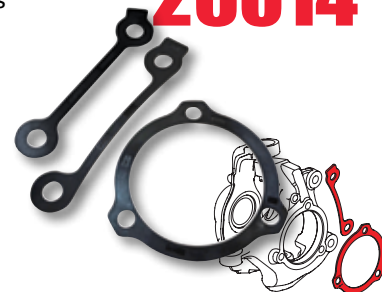

Front Adjustment range:

Camber/Caster +0.3° OR -0.3° (**FIXED change**)

Required: 1 per wheel **per adjustment**



28810 APPLICATIONS

- Mercedes:** 2001 - 07 C Class (W203, W204)
2005 - 11 CLS, SLK Class (W218, W219, R171, R172)
2004 - 09 CLK Class (C209)
2003 - 09 E Class (W211, W212)

28815 APPLICATIONS

- Chrysler:** 2004 - 08 Crossfire (Incl. SRT6)
- Mercedes:** 1994 - 00 C Class (W202)
2008 - 14 C Class (W204); 2000 - 06 CL Class (C215)
1998 - 02 CLK Class (C208)
2003 CLK Class (W208 Cabriolet)
2010 - 16 E Class (W212)
2003 - 09 E Class 4MATIC (W211)
2009 - 15 GLK Class (X204)
1999 - 05 S Class 4MATIC (W22)

For more Mercedes Applications check our website

MERCEDES CAMBER/CASTER CAM

28810 28815

Adjust camber or caster ±0.3° using the factory offset in the lower control arm bushings of many C and E Class platforms. Place the grooved bolt in the forward arm's bushing to change caster or in the rearward arm's bushing to change camber. If both camber and caster change are needed, you can use 2 kits.

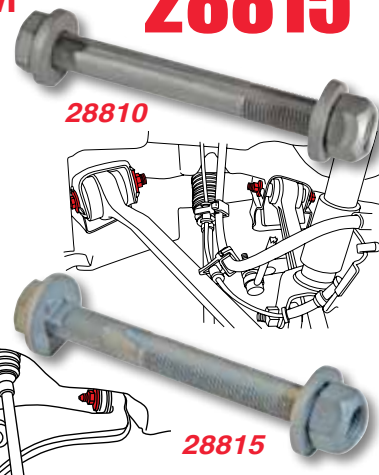

Rear Adjustment range: Camber ±1.25°

Required: 1 per wheel



28840 APPLICATIONS

- Chrysler:** 2004 - 08 Crossfire (Inc. SRT6)
- Mercedes:** 2001 - 07 C Class (W203)
1994 - 00 C Class (W202); 2004 - 09 CLK Class (W209)
1998 - 03 CLK Class (W208)
1996 - 02 E Class *Except Wagon* (W210)
1986 - 95 E Class (W124); 1999 - 02 SL Class (W129)
1996 - 11 SLK Class (R170, R171)

28850 APPLICATIONS

- Mercedes:** 2008 - 14 C Class (W204 & W205)
2009 - 15 GLK Class (X204)

28855 APPLICATIONS

- Mercedes:** 2015 & Up C Class Sedan (W205)
2010 - 16 E-Class
2017 E-Class Coupe & Conv. (A207 & C207)

28860 APPLICATIONS

- Mercedes:** 2003 - 09 E Class (W211)

NOTE: The 28850, 28855 and 28860 Camber Kits DO NOT fit AMG Models

MERCEDES REAR CAMBER KITS (PR)

28840 28850 28855 28860

These adjustable bushings make rear camber change possible for many Mercedes vehicles. By replacing the outer bushing in the two rear upper control arms, you achieve up to ±1.25° of change. Stock bushings are easily removed using the Specialty Products bushing press adapters.

- 72509** - Ball joint press, pg 169
- 28840** uses:
- 75990** - Ball joint press sleeves, pg 171
- 28850, 28855, 28860** uses:
- 76000** - Ball joint press sleeves, pg 171



Parts

35075
35076

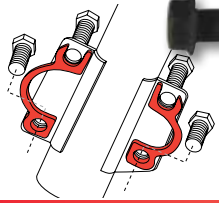

SPRINTER VAN FRONT ADJUSTER KIT (PR)

These shim kits let you change front camber on Dodge, Freightliner and Mercedes Sprinter Vans. Their unique design allows the technician to 'lock' the alignment settings. These shims install quickly and easily for time saving adjustments.

Front Adjustment range:
35075 Camber -1.0° (fixed)
35076 Camber -2.0° (fixed)

Required: 1 per wheel

APPLICATIONS

Dodge: 2003 - 06 Sprinter Van
Freightliner: 2002 - 05 Sprinter Van
Mercedes: 2001 - 06 Sprinter Van

35077



SPRINTER FRONT ADJUSTER KIT (PR)

Camber change on the 2007 and up Sprinter Van is quick, easy, and locked in with this SPC cam kit. Get up to $\pm 3.0^{\circ}$ camber change by simply removing the upper OE bolt, loosening the lower bolt, installing and adjusting this cam kit to the desired change and then tightening everything to specification. Save time, money and effort by making aligning this two bolt strut vehicle a one man job. Kit includes two cams.

Front Adjustment range:
Camber $\pm 3.0^{\circ}$

Required: 1 per axle

APPLICATIONS

Dodge: 2007 - 09 Sprinter Van
Freightliner: 2007 - 18
Sprinter Van
Mercedes: 2007 - 18
Sprinter Van

35080
SERIES



NISSAN CAM/CAS SHIMS

These shims install between the upper control arm mount and shaft to adjust Pathfinders and Pickups. **6 Shims per package**

35080 - 1mm **35081** - 2mm
35082 - 4mm

FRONT APPLICATIONS

Nissan RWD/4WD: 1987 - 95
Pathfinder; 1986 - 97 Pickup

Camber/Caster Shim Sets



37150 Duo-Fit

37150 DUO-FIT SET

Filled with 200 shims - **25 each** of all Duo-Fit styles and sizes **37100 through 37107** (below). Handy chart inside the lid makes reordering and organization simple. Comes in a durable plastic case.



47700 SLA

47700 SLA SET

These camber/caster shims (next page) are now available in a corrugated box set to help you organize all of your shims. Covering both cars and trucks this set is perfect for inventory control.

Contains 50 Each: 37105, 37106, 37107, 47151, 47152, 47153, 47181, 47182, 47183, 47766, 47767, 47768, 47775, 47776, 47777

Camber/Caster Duo-Fit

APPLICATIONS: Buick, Chevrolet, Ford, Lincoln, Mercury, Pontiac, Oldsmobile

Part No.	Thick.	Opening	Qty
37100	1/64"	7/16" to 1/2"	25
37101	1/32"	7/16" to 1/2"	25
37102	1/16"	7/16" to 1/2"	25
37103	1/8"	7/16" to 1/2"	25

APPLICATIONS: AMC, Buick, Cadillac, Chevrolet, Lincoln, Oldsmobile, Pontiac, Trucks

Part No.	Thick.	Opening	Qty
37104	1/64"	9/16" to 5/8"	25
37105	1/32"	9/16" to 5/8"	25
37106	1/16"	9/16" to 5/8"	25
37107	1/8"	9/16" to 5/8"	25

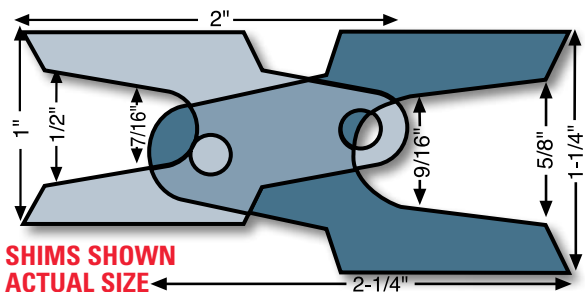

Parts Camber/Caster Shims

47142 - 47143 'BS'

Universal 1/2" slot shim	Part #	Thick.	Qty
	47142	1/16"	25
	47143	1/8"	25

47180 - 47184 'N'

Universal 1/2" slot shim	Part #	Thick.	Qty
	47180	1/64"	50
	47181	1/32"	50
	47182	1/16"	50
	47183	1/8"	50
	47184	3/16"	50

47150 - 47153 'US'

5/8" open. APPS.	Part #	Thick.	Qty
	47150	1/64"	50
	47151	1/32"	50
	47152	1/16"	50
	47153	1/8"	50

47762 - 47764 'X'

7/16" open. APPS.	Part #	Thick.	Qty
	47762	1/16"	50
	47763	1/8"	50
	47764	3/16"	50

47765 - 47769 'CT'

1/2" open. for imports APPS.	Part #	Thick.	Qty
	47765	1/64"	50
	47766	1/32"	50
	47767	1/16"	50
	47768	1/8"	50
	47769	3/16"	50

47775 - 47778 'CC'

9/16" open. H/D Trucks APPS.	Part #	Thick.	Qty
	47775	1/32"	50
	47776	1/16"	50
	47777	1/8"	50
	47778	3/16"	25

Including 1/2 -1 ton Chevrolet GMC trucks, HD service.

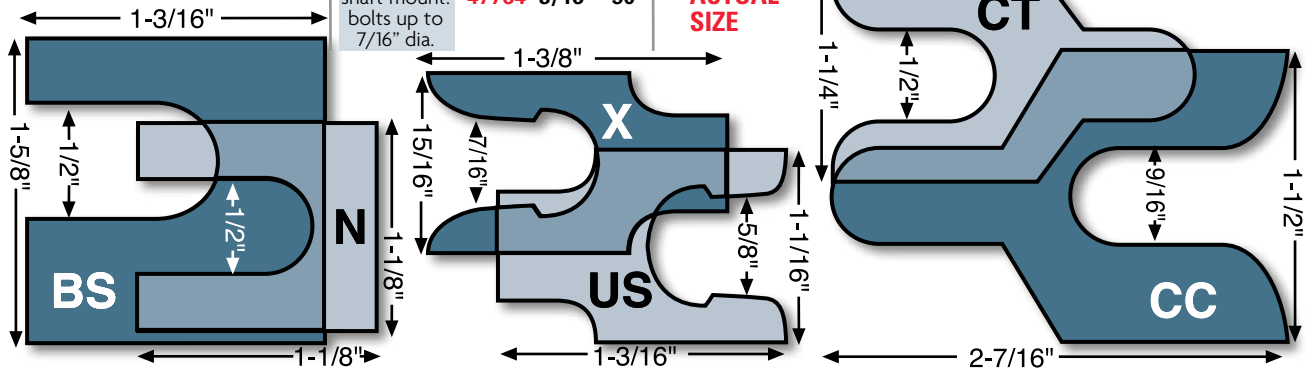

47171 - 1/32"	47172 - 1/16"
47173 - 1/8"	6 Shims per part #

REAR APPLICATIONS

Chevrolet: 1963 - 82 Corvette C2/C3

Look for our front adjustable arms for C2/C3 Corvettes on page 140

CORVETTE TOE SHIMS

Bring rear toe back into factory specification for C2 and C3 Chevy Corvettes with these stackable shims from SPC. The set includes 6 each of our 1/32", 1/16", and 1/8" shims (total 18 shims). Shims are also available in single size 6 packs.

Set 47170 contains 6 shims ea.: 1/32", 1/16", 1/8"



47240 - 1/32"	47241 - 1/16"
47242 - 1/8"	

Adjustment range: 1/32" to 1/8"

APPLICATIONS

Jeep: 1984 - 01 Cherokee
1986 - 92 Comanche
1993 - 04 Grand Cherokee
1984 - 90 Wagoneer

JEOP CASTER SHIMS

These shims provide positive caster changes on early model downsize Jeeps by installing them between the lower control arm and the frame bracket. Stackable for larger changes.

6 Shims per package

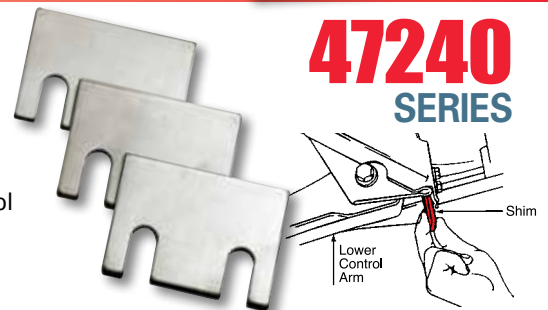

Required: 1 per axle

APPLICATIONS

63020 - 2-3/8" Width

Vehicles with 2-3/8" wide to 2-3/4" wide leaf springs inc. 60mm, 65mm and 70mm leaf springs of import trucks. All passenger vehicles with rear leaf springs.

63030 - 3" Width

Vehicles with 3", 3-1/2" and 3-5/8" wide leaf springs including 80mm, 90mm, and 100mm wide leaf springs.

This is THE kit to correct Thrust Angle!

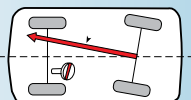

THRUST ALIGNMENT PLATE

Our thrust alignment plate will allow for corrections of setback and thrust angle on most vehicles with rear leaf springs. Installation is made by loosening the U-bolts holding the leaf spring to the axle, installing the alignment plate between the axle and leaf spring and re-tightening the U-bolts.

Widths are available in 2-3/8" and 3", and each kit comes with multiple parts to provide coverage of most vehicles with rear leaf springs, including all early model passenger cars.

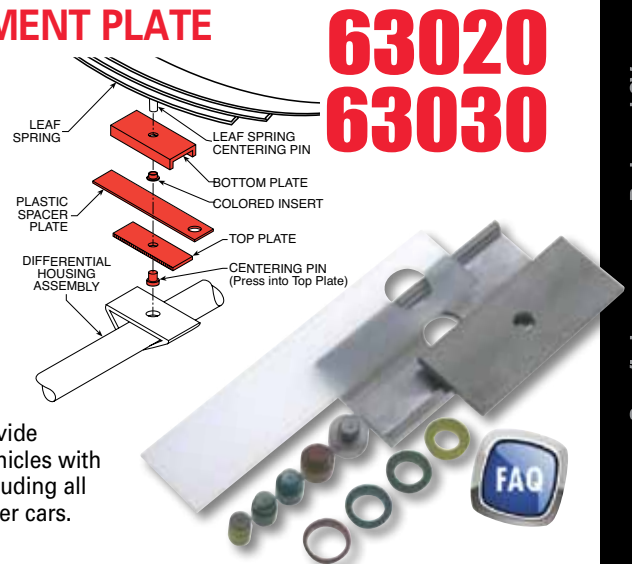

Parts

66037

CHRYSLER LX CAMBER/CASTER CAM

Adjust camber or caster $\pm 0.3^\circ$ using the factory offset in the lower control arm bushings of the popular Chrysler LX platform. Simply replace the OE lower control arm bolts with these grooved bolts to achieve the change the factory provides.

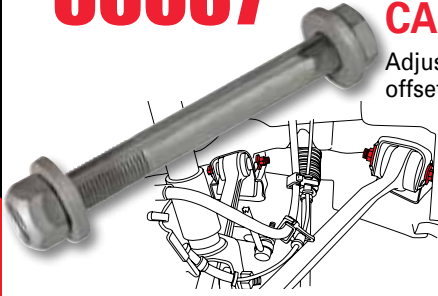

Need more adjustment? Replace the upper control arm with SPC's adjustable upper control arm - #66040, #66045 or #66047 (below).

Front Fixed Adjustment range:
Camber/Caster $+0.3^\circ$ OR -0.3°

Required: 1 per wheel per adjustment

APPLICATIONS RWD ONLY

Chrysler: 2005 - 10 300

Dodge:
2008 - 10 Challenger
2006 - 10 Charger
2005 - 08 Magnum

66038

DODGE/CHRYSLER LX CAMS (PR)

Add permanent adjustability to the front end of rear wheel drive Dodge Charger, Challenger, and Chrysler 300 vehicles with this cam bolt kit. The kit includes one camber cam and one caster cam to add adjustment to one side of the vehicle and gives $\pm 1.0^\circ$ camber adjustment and $\pm 2.0^\circ$ caster adjustment. These components offer the best corrosion protection available with a hex chromate free finish that is certified to meet 700hr salt spray test requirements. You will need SPC's punch tool #74920 or a rotary file like #85130 to slot the factory bolt holes.

NEW

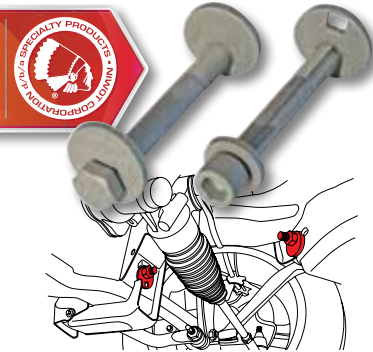

Front Adjustment range:

Camber $+1.0^\circ$ Caster $\pm 2.0^\circ$

Required: 1 per wheel

APPLICATIONS RWD ONLY

Chrysler: 2011 - 20 300

Dodge: 2011 - 20 Challenger
2011 - 20 Charger

Replace Mopar

#68142226AB with this kit.



74920 - Punch, pg 170

85130 - Rotary file, pg 173

66040 66045 66047

CHRYSLER/DODGE ARM

This adjustable front control arm fits these popular Dodge and Chrysler vehicles and provides both camber and caster changes. Easy to install and even easier to adjust this is the perfect kit for standard alignment issues as well as special suspension tuning problems that occur when you lower these vehicles for performance or appearance. Our 66040 and 66045 feature a fully forged arm while the 66047 features a tubular design, while both incorporate our low-profile adjustable ball joint. These arms fit both the left and right side.



66040
66045

66047

Patent No.
US 7,513,514

Front Adjustment range:

Camber $\pm 2.0^\circ$ Caster $\pm 1.0^\circ$

Required: 1 per wheel

66040 APPLICATIONS

Chrysler: 2005 - 08 300 RWD

Dodge: 2008 - 08 Challenger RWD
2006 - 08 Charger RWD
2005 - 08 Magnum RWD

66045 APPLICATIONS

Chrysler: 2009 & Up 300 RWD

Dodge: 2009 & Up Challenger RWD
2009 & Up Charger RWD

66047 APPLICATIONS

Chrysler: 2005 & Up 300 AWD

Dodge: 2017 & Up Challenger AWD
2006 & Up Charger AWD
2005 - 08 Magnum AWD

66050

CHRYSLER/DODGE REAR CAMBER KIT (PR)

This kit allows adjustment of rear camber on the Chrysler LX platform cars regardless of model year bushing size or arm construction. These "set-at-install" bushings can be clocked to provide up to $\pm 1.5^\circ$ of adjustment by replacing the outboard bushings on both upper control arms. Install these bushings without removing the control arms by using the #66025 adapter and the #40920 bushing press.



Rear Adjustment range:

Camber $\pm 1.5^\circ$

Required: 1 per wheel

APPLICATIONS

Chrysler: 2005 & Up 300

2004 - 08 Pacifica
Dodge: 2008 & Up Challenger
2006 & Up Charger
2005 - 08 Magnum



40920 - Performance Ball Joint Press, pg 165

66025 - Bushing Press Sleeves, pg 168

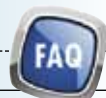

Rear Adjustment range: Toe $\pm 1.50^\circ$

Required: 1 per wheel

APPLICATIONS

- Chrysler:** 2005 & Up 300
2004 - 08 Pacifica
- Dodge:** 2008 & Up Challenger
2006 & Up Charger
2005 - 08 Magnum

-  **40920 - Performance Ball Joint Press, pg 165**
- 66025 - Bushing Press Sleeves, pg 168**

CHRYSLER/DODGE REAR TOE BUSHING

66055

Extend the range of rear toe adjustment by $\pm 1.5^\circ$ on the Chrysler LX platform by installing SPC's offset bushing. The OE toe cam on this platform gives you a $\pm 1^\circ$ adjustment, this is often not enough, especially if the vehicle has been modified. Replace the OE bushing with SPC's offset bushing, fine tune with the OE cam. Because the OE toe link is trapped, this kit is designed to replace the outer bushing while the arm is on the car to save time.

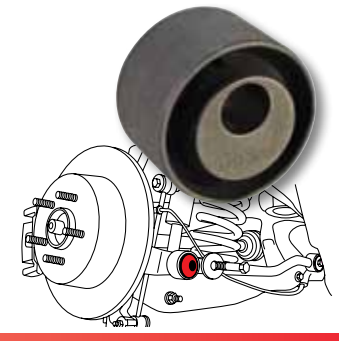

Rear Adjustment range: Camber $\pm 2.50^\circ$

Required: 1 per wheel

APPLICATIONS

- Chrysler:** 2007 - 10 Sebring
- Dodge:** 2008 - 10 Avenger
2009 - 10 Journey

CHRYSLER/DODGE EZ ARM XR™

67015

This fully adjustable EZ Arm provides rear camber changes of $\pm 2.5^\circ$. From street to track our adjustable control arm offers simple installation and adjustment for optimal performance.



Rear Adjustment range: Camber $\pm 4.00^\circ$

Required: 1 per wheel

APPLICATIONS

- Chrysler:** 2011 - 14 200
- Dodge:** 2011 - 14 Avenger
2011 & Up Journey

CHRYSLER JC/JS EZ ARM XR™

67018

This fully adjustable trailing link provides $\pm 4^\circ$ camber change for the rear of the Chrysler 200, Dodge Avenger and Journey. The simple to install "remove and replace" kit provides a lifetime of adjustability to maximize tire life and dial in handling.



Rear Adjustment range: Camber $\pm 3.50^\circ$

Required: 1 per wheel

APPLICATIONS

- Chrysler:** 2004 - 06 Sebring Sedan & Conv.
- Dodge:** 2004 - 06 Stratus Sedan

STRATUS AND SEBRING EZ ARM XR™

67025

Adjust rear camber on 2004 - 06 Sebring and Stratus sedans up to $\pm 3.5^\circ$ with this control arm. Simply replace the non-adjustable OE arm with the EZ Arm XR, and you can adjust the rear camber.

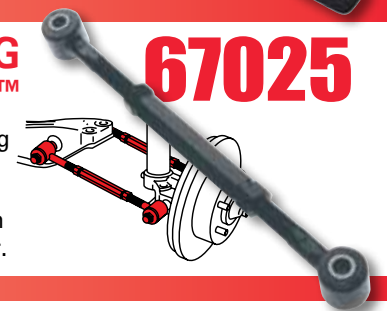

Rear Adjustment range: Camber -2.00° to $+5.00^\circ$

Required: 1 per wheel

APPLICATIONS

- Acura:** 1997 - 00 EL
1990 - 01 Integra
- Honda:** 1988 - 00 Civic; 1997 - 01 CR-V
1988 - 92 CRX; 1992 - 97 Del Sol

HONDA/ACURA REAR EZ ARM XR™

67030

These arms are for vehicles that retain the stock ride height or have been lowered for performance. Replace the OE arm with the EZ Arm XR, and adjust the rear camber -2° to $+5^\circ$.

NOTE: Some vehicles may need longer bolts when using this arm. Use set #73415 found on page 115.



Rear Adjustment range: Camber -2.00° to $+3.50^\circ$

Required: 1 per wheel

APPLICATIONS

- Acura:** 1997 - 99 CL
1996 - 98 TL
1992 - 94 Vigor
- Honda:** 1990 - 97 Accord

HONDA/ACURA REAR EZ ARM XR™

67065

These arms correct rear camber on stock ride height vehicles and vehicles that have been lowered up to 1.5" with an adjustment range of -2.0° to $+3.5^\circ$ with a non-directional ball joint preinstalled. (Extreme drops use #67265 page 90).

Replacement ball joint - available #67075, page 153.



67080

CHRYSLER LH EZ ARM XR™

Adjust rear camber on 1998 to 2004 Chrysler LH bodies with this control arm. Simply replace the OE arm with the EZ Arm XR, and you can adjust the rear camber.

** For positive camber changes larger than 1.0° install two (2) EZ Arms™ on each side.*

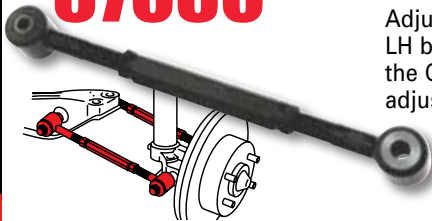

Rear Adjustment range:
Camber -2.00° to +1.00°*

Required: 1 per wheel

APPLICATIONS

Chrysler: 1999 - 04 300M
1998 - 04 Concorde
1998 - 01 LHS

Dodge: 1998 - 04 Intrepid

67090 67095

HONDA/ACURA REAR EZ ARM XR™

For many Hondas and Acuras, these arms have an OE style ball joint integrated into a complete arm assembly and they have a full 6° range of rear camber change with our turnbuckle adjustment system.

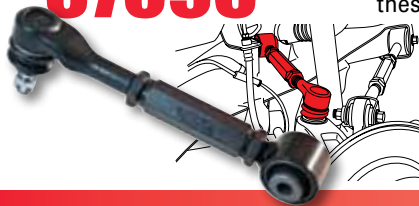

Rear Adjustment range:
Camber -2.00° to +4.00°

Required: 1 per wheel

67090 APPLICATIONS

Acura: 2001 - 04 CL; 1996 - 04 RL; 1999 - 03 TL
Honda: 1998 - 02 Accord

67095 APPLICATIONS

Acura: 2004 - 08 TL

67105

1 & 3 SERIES BMW ADJ. CAMBER ARM

Factory camber adjustment on the rear of the BMW 1 & 3 Series is limited and often not enough. Use SPC's rear camber arm to get an additional ±3° of camber on the E90, E91, E92, & E93 as well as the E82 & E88 models. Simply replace the OE link with SPC's adjustable link and adjust camber to minimize tire wear, optimize handling, or get ready for the track. Once camber is where you want it, set toe with the OE cam and you are good to go. This arm is equipped with SPC's xAxis™ ball joint and a bonded rubber bushing to maintain factory ride quality.



Rear Adjustment range:
Camber ±3.00°

Required: 1 per wheel

APPLICATIONS

BMW: 2008 - 13 1 Series
Incl 1M Coupe
2007 - 13 3 Series
(Coupe & Conv.)
2006 - 12 3 Series
(Sedan & Wagon)
2007 - 13 M3

67108

BMW/MINI REAR ADJ. CONTROL ARM

Get ±3° of camber adjustment on your late model BMW or MINI with this rear camber arm from SPC. Whether you need to improve tire life, add aggressive camber settings for the track, or just want a better handling car for the street, this is the arm for you. The high strength steel arm features fully forged ends and high durometer rubber bushings for long life, minimized noise, vibration, and harshness (NVH), and great handling characteristics. The easy to adjust turnbuckle and the remove and replace design make this a hassle free install with lifetime adjustability.



Rear Adjustment range:
Camber ±3.00°

Required: 1 per wheel

APPLICATIONS

BMW: 2016 & Up X1 (F48)
2018 X2 (F38)
MINI: 2014 & Up Cooper 3-Door
(F55/F56)
2016 & Up Cooper
Clubman (F54)
2016 & Up Cabrio (F57)
2017 & Up Countryman
(F60)

Rear Adjustment range: Camber -1.00° to +3.00°

Required: 1 per wheel

APPLICATIONS

- BMW:** 2000 - 06 3 Series Coupe and Convertible (E46)
 1999 - 05 3 Series Sedan and Wagon (E46)
 1992 - 99 3 Series 318, 323 and M3 (E36)
 2003 - 08 3 Series Z4 (E85)



87565 - Rear Toe Adjusting Tool, pg 174

BMW REAR CAMBER ARM

67110

For BMW E36, E46 and E85 bodied vehicles this tubular style arm is great when lowering this popular vehicle, or for correcting rear camber on stock vehicles.

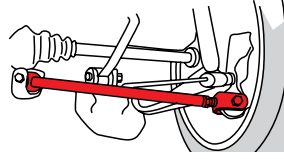

For high performance applications check out our billet aluminum arm (#72110) on page 107.



Adjustment range: Camber ±1.50°

Required: 1 per wheel



APPLICATIONS FRONT

- 67115 Ford:** 2006 - 12 Fusion **Mazda:** 2003 - 08 Mazda6
Lincoln: 2007 - 12 MKZ **Mercury:** 2006 - 11 Milan
 2006 Zephyr

- 67125 Acura:** 2001 - 04 CL; 1997 - 99 CL (w/35.3mm Ball Joint Dia.)
 1999 - 08 TL; 1996 - 98 TL 2.5; 2004 - 08 TSX
Honda: 1998 - 02 Accord; 1988 - 91 Civic; 1988 - 92 CRX
 1995 - 98 Odyssey
Isuzu: 1996 - 99 Oasis

- 67135 Acura:** 1997 - 00 EL; 1990 - 01 Integra; 1991 - 96 Legend
 1996 - 04 RL; 2009 - 14 TL; 1996 - 98 TL 3.2
 2009 - 14 TSX
Honda: 2003 - 12 Accord; 2010 - 15 Accord Crosstour
 1992 - 00 Civic; 1997 - 01 CRV
 1992 - 97 Del Sol
 1997 - 02 Prelude (Non-SH)

- 67145 Acura:** 1997 - 99 CL (w/33.5mm Ball Joint Dia.)
Honda: 1990 - 97 Accord

- 67165 Acura:** 1992 - 94 Vigor
Honda: 1992 - 96 Prelude; 1997 - 02 Prelude SH
 1992 - 94 Prelude 4WS

- 67180 Chrysler:** 1995 - 00 Cirrus; 2001 - 06 Sebring Sedan
 1996 - 06 Sebring Conv.
Dodge: 1995 - 06 Stratus Sedan
Plymouth: 1996 - 00 Breeze

- 67190 Hyundai:** 2006 Azera (before 10/31/06)
 1999 - 06 Sonata (before 9/21/06); 2001 - 05 XG300/350
Kia: 2004 - 06 Amanti; 2001 - 06 Optima

- 67195 Hyundai:** 2007 - 11 Azera (after 10/31/06)
 2007 - 10 Sonata (after 9/21/06)
Kia: 2007 - 11 Amanti

APPLICATIONS REAR

- 67155 Honda:** 1995 - 98 Odyssey; 1997 - 02 Prelude SH
Isuzu: 1996 - 99 Oasis

- 67165 Honda:** 1992 - 02 Prelude

ADJUSTABLE BALL JOINT

67115 67125 67135 67145 67155 67165 67180 67190 67195

These adjustable upper ball joints allow for front camber adjustments for many vehicles with upper control arms. By replacing the factory ball joint, this sliding ball joint allows for greater changes than previously available. With an OE quality replacement ball joint, this sliding plate assembly is perfect for vehicles that have been lowered for performance, or retain the factory ride height. For changes greater than +1.5° check out our Extended Range Ball Joints on page 92.

- Best clearance in the industry
- Exclusive 'low-profile' design
- OE strength built-in
- Preferred by professional installers



40920 - Perf. Ball Joint Press, pg 165

See our Adjustable Ball Joint for Honda S2000 on pg 90

See our Adjustable Ball Joint for Lexus on pg 97

Featured Owner: Matt Mitchell

Matt's FJ is something special. It's the first FJ ever to be on a 10" IFS suspension lift (all custom) on 24x14 rbp forged hand painted wheels wrapped in 40x15.50 tires. And to keep that suspension happy it has SPC's Adjustable Front Control Arms (#25480, page 81). The mods don't stop there, its got everything from custom bumpers, to waterproof marine audio on the roof rack, over 20 rigid industries lights, fiberglass hood, you name it, Matt's got it.



Applications
Alignment Parts
Heavy Duty
OE Replacement
Racing/Builders
Tools
Brake and CV

Applications

Alignment Parts

Heavy Duty

OE Replacement

Racing/Builders

Tools

Brake and CV

Gear/Driv

67210

NEON EZ ARM XR™ (PR)

These control arms make it possible to adjust rear camber and toe on all Dodge and Plymouth Neons, including the SRT 4. These arms may be used on vehicles that have been lowered as well as vehicles that have retained their stock ride height. When two arms are used on each side you can change both camber and toe $\pm 3.0^\circ$. If you use just one arm on each side only $\pm 1.5^\circ$ toe change is available.

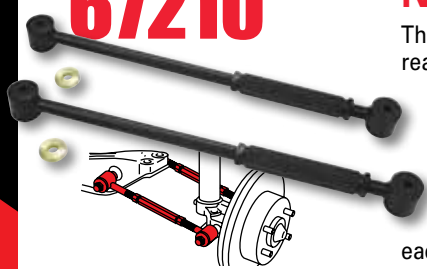

Rear Adjustment range:
1 Kit per Axle Toe Only $\pm 1.50^\circ$
2 Kits per Axle Toe $\pm 3.00^\circ$
Camber $\pm 3.00^\circ$

Required: 1 or 2 per Axle (above)

APPLICATIONS

Dodge/Plymouth: 1994 - 06 Neon
Including SRT 4

Note: Each kit includes 2 arms

67220

HONDA S2000 BALL JOINT

Designed specifically for the S2000, this ball joint corrects camber on both the front and rear. An OE quality ball joint, this adjustable ball joint corrects camber up to $\pm 1.5^\circ$.



***NOTE:** This ball joint is **ONLY** for vehicles equipped with rims (both front and rear) that are 17" or larger

Front/Rear* Adjustment range:
Camber $\pm 1.5^\circ$

Required: 1 per wheel

APPLICATIONS

Honda: 2000 - 09 S2000

 **40920 - Perf. Ball Joint Press, pg 165**

67230

HONDA/ACURA EZ ARM XR™

This EZ Arm corrects rear camber on Honda's redesigned 2001 - 05 Civic along with the 2002 - 06 Acura RSX. Simply replace the OE arm with this arm, perfect for stock height and lowered vehicles.



Rear Adjustment range:
Camber -4.00° to $+6.00^\circ$

Required: 1 per wheel

APPLICATIONS

Acura: 2001 - 05 EL; 2002 - 06 RSX
Honda: 2001 - 05 Civic

67265

EXTENDED RANGE HONDA/ACURA REAR EZ ARM XR™

These arms correct rear camber on vehicles that have been lowered up to 3.0" with an adjustment range of -2.0° to $+3.5^\circ$. The "bent" design of the arm gives extra clearance. 67265 comes with a non-directional ball joint preinstalled. (Stock vehicles - use 67065 page 87). Replacement Ball Joint 67075 (page 153).

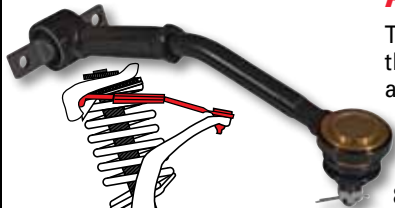

Rear Adjustment range:
Camber -2.00° to $+3.50^\circ$

Required: 1 per wheel

APPLICATIONS

Acura: 1997 - 99 CL
1996 - 98 TL
1992 - 94 Vigor
Honda: 1990 - 97 Accord

67270

SATURN REAR EZ ARM XR™

Designed to adjust camber on the Saturn "L" series cars, this arm is easy to install and provides rear camber adjustment for the life of the vehicle. With its 8° adjustment range this arm can handle extreme amounts of camber changes that may be needed if you lower the Saturn "L".

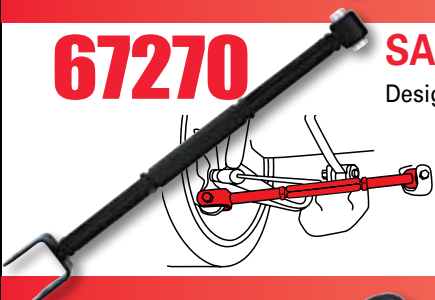

Rear Adjustment range:
Camber $\pm 4.00^\circ$

Required: 1 per wheel

APPLICATIONS

Saab: 2000 - 09 9-5
w/o Auto Leveling Headlights
Saturn: 2000 - 05 L-Series

67275

FORD ADJUSTABLE CAMBER ARM

Add more adjustment to the rear suspension on your Ford Expedition with this fully adjustable camber control arm. This arm replaces the factory non-adjustable upper control arm and allows easy on-car adjustment to dial in the camber exactly where you want it. The bonded rubber bushing retains factory ride and vibration quality while providing a long service life.

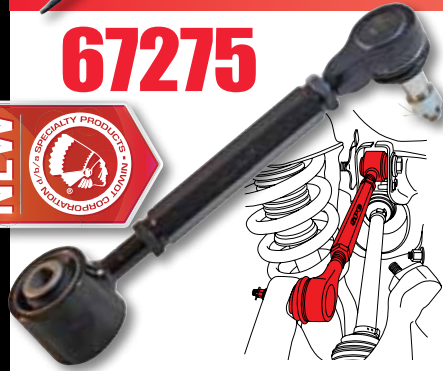

Rear Adjustment range:
Camber $\pm 3.0^\circ$

Required: 1 per wheel

APPLICATIONS

Ford: 2007 - 17 Expedition
Lincoln: 2007 - 17 Navigator



Rear Adjustment range:
Camber: $\pm 2.00^\circ$
Required: 1 per wheel

APPLICATIONS

- Ford FWD/AWD:**
2001 - 12 Escape
- Mazda FWD/AWD:**
2001 - 11 Tribute
- Mercury FWD/AWD:**
2005 - 11 Mariner



ESCAPE/TRIBUTE REAR CAMBER ARM

67285

Correct camber on previously non-adjustable suspensions with this adjustable control arm. The remove and replace design makes the arm ideal for quick and easy alignment adjustment as well as simple chassis part replacement. The adjustable arm has an easy to access turnbuckle design that adjusts camber $\pm 2.0^\circ$, factory toe adjustments can then be used to complete the alignment.

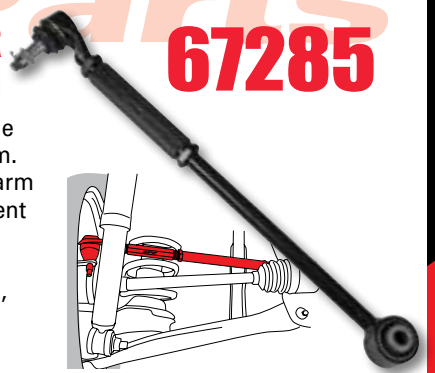

Rear Adjustment Range:
67289 (5 ARM SET)
Camber: $\pm 3.0^\circ$
Toe: $\pm 3.0^\circ$
Setback: $\pm 1.0''$

- 67290** Camber: -2.0° to $+4.0^\circ$
- 67291** Camber: $\pm 3.0^\circ$
- 67292** Setback: $\pm 1''$
- 67293** Setback: $\pm 1''$
- 67295** Toe: $\pm 3.0^\circ$

Required: 1 per wheel

APPLICATIONS

- 67289, 67290, 67291, 67292, 67293, 67295**

- Acura:** 2004 - 08 TSX
- Honda:** 2003 - 07 Accord

67290 ONLY

- Acura:** 2001 - 06 MDX
- Honda:** 1999 - 04 Odyssey
2003 - 08 Pilot

HONDA/ACURA 5 ARM SET

67289

Use this five (5) link set to adjust camber, toe, set-back, and track width on your Accord, TSX, and many more Honda & Acura models. Whether you are modifying your suspension for the track or getting your alignment angles back after adjusting ride height, this is the most comprehensive kit for you. Honda's multilink set-up is susceptible to binding if you try to change the length of just one of the arms. This kit corrects that and will let you set your suspension where you want it without binding.

Attention: The sequence of arm adjustments made is extremely important when upgrading this multi-link system.

- Upper Camber 67290**
- Lower Camber 67291**
- Lower Setback 67292**
- Upper Setback 67293**
- Toe 67295**



See the web for in-depth information on this kit and how it will work in the Honda/Acura multi-link suspension.

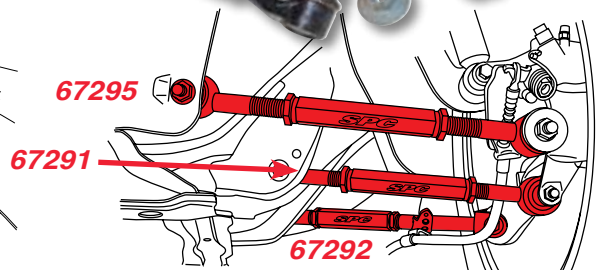
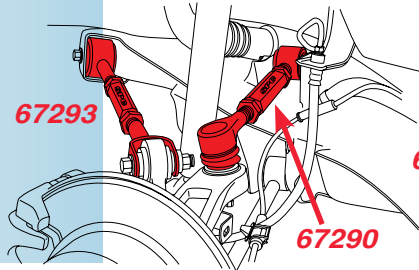

67290 - UPPER CAMBER LINK WITH BALL JOINT

Adjust camber -2° to $+4^\circ$ with this adjustable control arm. This link comes with two flanged castle nuts so it will fit correctly in both steel and aluminum knuckles.

67291 - LOWER CAMBER LATERAL LINK

Use this arm to affect setback, camber and track width. This arm ties into the knuckle directly below the 67290. Adjusting this in unison with the upper link will take bind out of the system.

67292 - LOWER FORWARD LATERAL LINK

Use this arm to affect setback and toe. These links have bonded rubber bushings to maintain factory levels of noise vibration and harshness (NVH).

67293 - UPPER REARWARD LATERAL LINK

Use this arm to affect setback and track width. The arm's adjustability will allow you to remove bind as you adjust camber with the other arms.

67295 - TOE LINK

Use this arm to affect toe and track width. The kit also includes a replacement bolt and nut for the inboard end where we have found the OE cam bolt is often corroded and gets destroyed upon removal.

Parts

67300

These Jounce Spacers are featured on our 72123 and 72130 Nissan arms



JOUNCE SPACERS (4)

Dial in your up-travel stops on coil over suspensions. These easy to use Jounce Bumper Spacers allow you to control up-travel by simply placing urethane spacers between your factory bump stop and the shock body. The closed wedge design allows you to install the spacers without removing the spring or disassembling your strut. Take them out as easily as you put them in if you want to increase up travel. Each of the four spacers will decrease your up-travel by 8mm at the strut.

67320 67330 67340 67360

EXTENDED RANGE ADJUSTABLE BALL JOINT

Able to change camber from +1.50° up to +3.0° these ball joints are perfect for lowered vehicles. For changes less than +1.5° check out our **Adjustable Ball Joints** on page 89.

These ball joints have the best clearance in the industry - thanks to our exclusive 'low-profile' design. And with OE strength built in, our ball joints are the ones that more pro installers use.

 **40920 - Perf. Ball Joint Press, pg 165**

Adjustment range: Camber +1.50° to +3.00°

Required: 1 per wheel



APPLICATIONS FRONT

67320 Acura: 2001 - 04 CL; 1997 - 99 CL (w/35.3mm Ball Joint Dia.)
1999 - 08 TL; 1996 - 98 TL 2.5; 2004 - 08 TSX

Honda: 1998 - 02 Accord; 1988 - 91 Civic
1988 - 92 CRX; 1995 - 98 Odyssey

Isuzu: 1996 - 99 Oasis

67330 Acura: 1997 - 00 EL; 1990 - 01 Integra; 1991 - 96 Legend
1996 - 04 RL; 2009 - 14 TL; 1996 - 98 TL 3.2
2009 - 14 TSX

Honda: 2003 - 12 Accord; 2010 - 15 Accord Crosstour
1992 - 00 Civic; 1997 - 01 CRV; 1992 - 97 Del Sol
1997 - 02 Prelude (Non-SH)

67340 Acura: 1997 - 99 CL (w/33.5mm Ball Joint Dia.)
Honda: 1990 - 97 Accord

67360 Acura: 1992 - 94 Vigor
Honda: 1992 - 96 Prelude
1997 - 02 Prelude SH
1992 - 94 Prelude 4WS

APPLICATIONS REAR

67360 Honda: 1992 - 02 Prelude

67381 67382

HONDA ADJUSTABLE LOWER BALL JOINT

Use this adjustable ball joint to get back to specification on the Honda Civic, CR-V, and Accord. Whether you are tracking your vehicle or need some change to stop tire wear, this maintenance free sealed ball joint will do the job. SPC's ball joint will give up to -1° change on the Civic and up to -0.5° on the taller strutted CR-V and Accord. Need positive change? SPC's ball joint #67382 will give up to +1° change on the Civic and up to +.5° change on the CR-V. **NOTE: DOES NOT FIT CIVIC TYPE R.**

Front Camber Adjustment range:

67381 Civic: 0° to -1.0°
Accord & CR-V: 0° to -.5°

67382 Civic: 0° to +1.0°
Accord & CR-V: 0° to +.5°

Required: 1 per wheel

APPLICATIONS

Honda:
2018 Accord
2016 & Up Civic (not Type R)
2017 & Up CR-V

OE Replacement ball joint available - #12715, page 151.

67410

HYUNDAI/KIA REAR EZ ARM XR™

This adjustable rear upper control arm and toe cam kit, for many Hyundai and Kia models, will provide up to ±2° camber and ±2° toe change.

 **85130 - Rotary File, pg 173**

Rear Adjustment range:
Camber ±2.0°/Toe ±2.0°

Required: 1 per wheel



APPLICATIONS

Hyundai: 2007 - 10 Elantra
2011 - 12 Elantra Touring

Kia: 2007 - 10 Optima
2007 - 12 Rondo

Rear Adjustment range:
Camber $\pm 3.00^\circ$ Toe $\pm 1.50^\circ$
Required: 1 per wheel

67415 APPLICATIONS

Mazda: 2014 - 18 Mazda3

67416 APPLICATIONS

Mazda: 2013 & Up CX-5



85130 - Rotary File, pg 173

MAZDA3 & CX-5 REAR CAMBER/TOE KIT

Make rear camber on the Mazda3 and CX-5 adjustable for life with this adjustable lower control arm and extended range toe cam kit. The remove and replace camber arm provides $\pm 3.0^\circ$ of change and the included extended range toe cam will get toe back to specification through the entire camber range. Whether you need to improve handling or to decrease tire wear issues, this is the kit for you. Use rotary file #85130 to extend the factory toe slot and take advantage of the full throw provided by the SPC's extended toe cam bolt. The 67416 also includes an optional bracket for use with '17 & newer models that include an air dam on the lower control arm.



67415
67416

67415

67416



Applications
Alignment Parts
NEW
Heavy

Rear Adjustment range:
Toe $\pm 1.50^\circ$
Required: 1 per wheel

APPLICATIONS

Mazda: 2014 - 18 Mazda3
2013 - 19 Mazda CX-5



85130 - Rotary File, pg 173

MAZDA REAR TOE CAM

Replace your frozen toe cams on many Mazda vehicles while also adding more adjustability with this extended range toe adjustment kit from SPC. This cam bolt provides $\pm 2.5^\circ$ of adjustment through the unique stepped cam washer included in the kit. Use rotary file #85130 to extend the factory toe slot to take full advantage of the extended range on this cam bolt.

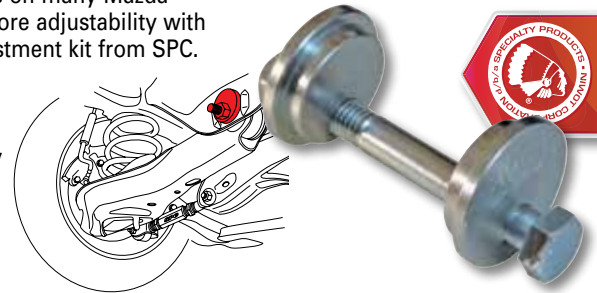

67417



NEW

Rear Camber Adjustment
Required: 1 per wheel



67420 Rear Camber -1.5° to $+5.0^\circ$

APPLICATIONS

Ford: 2013 - 18 C-Max; 2013 & Up Escape
2000 - 18 Focus

Mazda: 2004 - 13 Mazda3; 2006 - 15 Mazda5

Volvo: 2008 - 13 C30; 2006 - 13 C70
2004 - 12 S40; 2004 - 11 V50

67440 Rear Camber $\pm 3.0^\circ$

APPLICATIONS

Toyota: 2000 - 05 Celica

CELICA, FORD, MAZDA3, VOLVO, FORGED REAR CAMBER ARM

These high strength forged rear arms are perfect for tuners or installers that need extended camber ranges on these popular platforms. Complete with OE style bushings installed for a factory type ride.



67420
67440

Racing/Builders
Tools
Brake and CV

Rear Adjustment range:
Camber $\pm 2.0^\circ$
Required: 1 per wheel

APPLICATIONS

Ford: 2006 - 12 Fusion

Lincoln: 2006 - 12 Zephyr/MKZ

Mazda: 2003 - 13 Mazda6

Mercury: 2006 - 11 Milan

MAZDA6 & FORD FUSION ADJUSTABLE REAR CAMBER ARM

These high strength forged adjustable rear arms are the answer for tuners and installers needing extended camber adjustment ranges (up to $\pm 2.0^\circ$). The arm includes SPC's xAxis™ Sealed Flex joint for improved durability and minimized deflection providing improved handling performance.

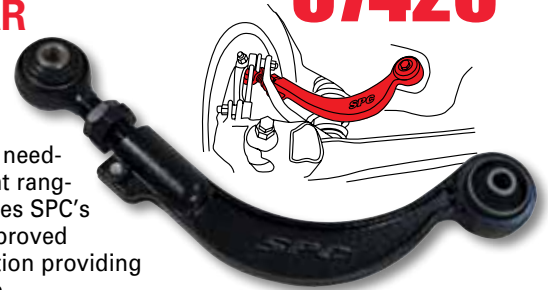

67425

Gear/Index

Parts

67430

HONDA CR-V REAR EZ ARM XR™

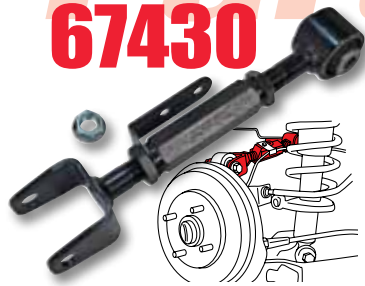

These arms fit popular CR-Vs and Elements. By removing the stock upper rear control arm and replacing it with the adjustable arm you can adjust camber either positive or negative with the turnbuckle adjuster. This arm can be used on vehicles with stock ride height or vehicles that have been altered for performance.

Rear Adjustment range:
Camber. -2.00° to +4.00°

Required: 1 per wheel

APPLICATIONS

Honda: 2002 - 06 CR-V
2003 - 11 Element

67455

DODGE/JEEP REAR CAMBER ARM

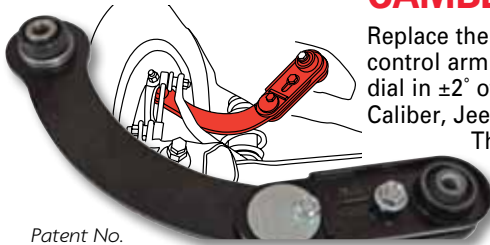

Patent No.
US 8,746,714

Replace the non-adjustable rear upper control arm with this adjustable arm to dial in $\pm 2^\circ$ of rear camber on the Dodge Caliber, Jeep Compass and Patriot.

This remove and replace arm includes an OE style xAxis™ ball joint and bonded rubber bushing to match chassis design parameters and OE ride quality.

Rear Adjustment range: Camber. $\pm 2.00^\circ$

Required: 1 per wheel

APPLICATIONS

Dodge AWD/FWD:
2007 - 12 Caliber

Jeep AWD/FWD:
2007 - 17 Compass; 2007 - 17 Patriot

Mitsubishi AWD/FWD:
2008 - 17 Lancer
2007 & Up Outlander
2011 & Up Outlander Sport



67465

CIVIC CAMBER BRACKET



This rear bracket and bushing replaces the stock mount on 8th/9th Gen Civics. By rotating the eccentric bolt/cam assembly in the bracket, you can get $\pm 1.25^\circ$ of rear camber change. Use the #75980 bushing removal press to remove the old bushing and to press in the new bushing. If more change is needed for lowered/performance applications check out our #67466 (below) or #67475 rear arm kits (next page).

Rear Adjustment range:
Camber $\pm 1.25^\circ$

Required: 1 per wheel

APPLICATIONS

Acura: 2006 - 11 CSX
2013 & Up ILX

Honda: 2006 - 15
Civic (Incl. Si/Hybrid)



75980 - Bushing Sleeves, pg 171
72509 - Ball Joint Press, pg 169

67466

HONDA CIVIC CAMBER ARM

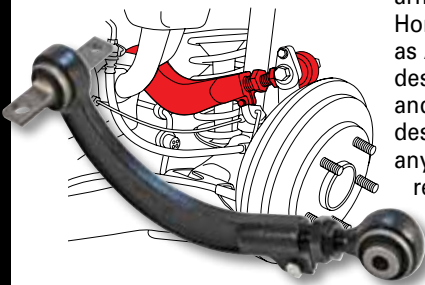

Use this remove and replace adjustable control arm from SPC to make rear camber changes on Honda's 8th and 9th generation Civics as well as Acura CSX & ILX. SPC's unique adjustment design permits on car adjustment of $\pm 3^\circ$ camber and is adjustable for life. SPC's forged steel design adds adjustment to the arm without any weight penalty vs. the OE arm it will replace. Whether you need negative camber and reduced compliance for the track or want to get back to OE specifications after lowering, this is the arm for you.

Rear Adjustment range:
Camber $\pm 3.0^\circ$

Required: 1 per wheel

APPLICATIONS

Acura: 2006 - 11 CSX
2013 & Up ILX

Honda: 2006 -15 Civic
(Incl. Si/Hybrid)

Why all the options for the same application?

We are often asked this question and many times it involves specific options that we want to provide to the installer. In the case of the 8th and 9th generation Civics these vehicles cross many markets - from grocery getters to tuner to track. The three rear alignment part options for this application are specifically targeted for these specific uses.

Honda 2006 & Up Civic, (Incl. Si, Hybrid) Acura 2006 - 11 CSX; 2013 & Up ILX	REAR Camber Change	Install Time	Construction	Bushing	Weight
Good 67465	$\pm 1.25^\circ$.75 hr/side	Stamped Steel	Replace OE Inner	> OE
Better 67466	$\pm 3.0^\circ$.5 hr/side	Forged Steel	OE Style	= OE
Best 67475	$\pm 3.0^\circ$.5 hr/side	Forged Aluminum	xAxis™ Outer	< OE

Rear Adjustment range:
Camber $\pm 3.0^\circ$

Required: 1 per wheel

APPLICATIONS

Honda: 2016 & Up Civic
(Except Type R)
2019 - 20 Insight

CIVIC REAR ADJUSTABLE CONTROL ARM

67467

Remove and replace your factory rear upper control arm with SPC's adjustable arm to make rear camber changes on your 10th generation Civic. SPC's unique adjustment design permits on car adjustment of $\pm 3.0^\circ$ camber and is adjustable for life. SPC's forged steel design adds adjustment to the arm without a weight penalty vs. the OE arm it will replace. Whether you need negative camber and reduced compliance for the track or want to get back to OE specifications after lowering, this is the arm for you.

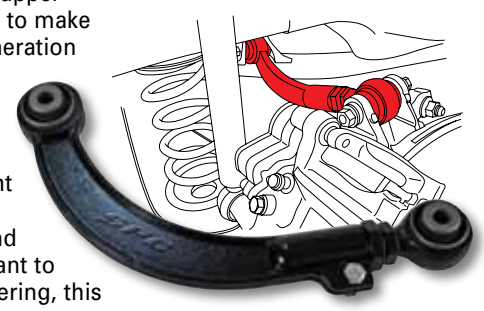

Rear Adjustment range:
Camber $\pm 3.0^\circ$

Required: 1 per wheel

APPLICATIONS

Acura: 2006 - 11 CSX
2013 & Up ILX

Honda: 2006 - 15 Civic
(Incl. Si and Hybrid)

HONDA/ACURA CAMBER ARM

67475

Get your 8th and 9th generation Civic or Acura CSX & ILX track ready with SPC's aluminum adjustable rear camber arm. SPC aluminum arm weighs less than the OE arm it will replace. The arm is built with SPC's xAxis™ sealed flex joint to reduce compliance. Its unique adjustment design permits on car adjustment of $\pm 3^\circ$ camber. Whether you need negative camber and reduced compliance for the track or want to get back to OE specifications after lowering, this is the arm for you.

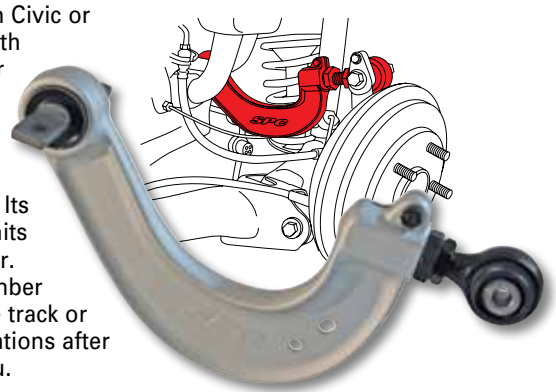

Rear Adjustment range:
Camber $\pm 3.0^\circ$

Required: 1 per wheel

APPLICATIONS

Honda: 2018 Accord
2016 & Up Civic
(Incl. Si and Type R)
2017 & Up CR-V

CIVIC REAR CAMBER ARM

67476

Get your 10th generation Civic ready for the track with SPC's aluminum adjustable rear camber arm. SPC's aluminum arm weighs less than the OE arm it will replace. The arm is built with SPC's xAxis™ sealed flex joint to reduce compliance. Its unique adjustment design permits on-car adjustment of $\pm 3.0^\circ$ camber. Whether you need negative camber and reduced compliance for the track or want to get back to OE specifications after lowering, this is the arm for you. Includes bracket for installing on Type Rs.

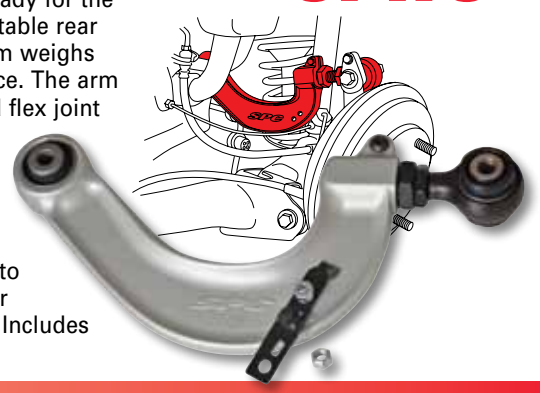

Rear Adjustment range:
(Includes the camber adjustment built-in from the factory)
Camber $+3.25^\circ$

Required: 1 per wheel

APPLICATIONS

Scion: 2005 - 10 tC

SCION tC REAR ARM

67485

This fixed change arm is ideal for correcting excessive negative camber issues seen in lowered Scion tC's. The Scion tC comes from the factory with a cam bolt that provides $\pm 1.25^\circ$. This factory change is not enough change for lowered applications. By increasing the length of the rear upper control arm SPC Performance adds 2° positive camber to the rear suspension that can then be dialed in with the OE cam bolt.



Parts

Applications

Alignment Parts

Heavy Duty

OE Replacement

Racing/Builders

Tools

Brake and CV

Gear/Index

67487

SCION tC REAR ARM

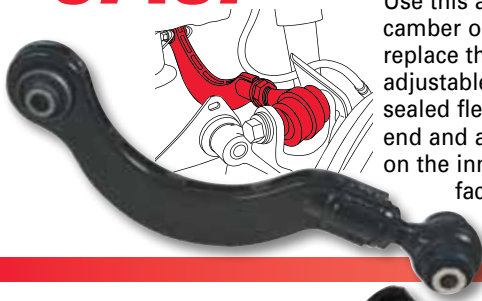

Use this adjustable control arm to dial in rear camber on the 2011 and up Scion tC. Simply replace the rear upper control arm with this adjustable arm. Arm includes SPC's xAxis™ sealed flex joint on the outboard end and a bonded rubber bushing on the inner end to maintain factory ride characteristics.

Rear Adjustment range:
Camber $\pm 2.00^\circ$

Required: 1 per wheel

APPLICATIONS

Lexus: 2011 - 17 CT
2010 - 12 HS
Scion: 2011 - 16 tC; 2016 iM
Toyota: 2017 & Up Corolla iM

67490

HONDA RIDGELINE REAR EZ ARM XR™

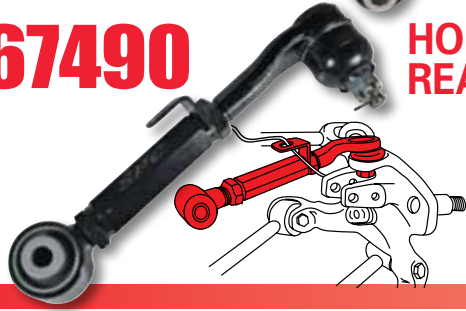

This rear camber arm for the Honda Ridgeline has an OE style ball joint integrated into it and has a full 4° of camber change using our turnbuckle adjustment system.

Rear Adjustment range:
Camber $\pm 2.00^\circ$

Required: 1 per wheel

APPLICATIONS

Honda: 2006 - 14 Ridgeline

67493

HYUNDAI SANTA FE REAR CAMBER/TOE BOLTS (PR)

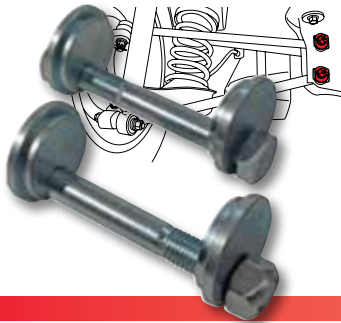

Double the change provided by the OE cams for camber and toe on the rear of the 2001 to 2006 Hyundai Santa Fe by using SPC's replacement cams. Use SPC's Rotary File #85130 to elongate the OE slot and take advantage of this cam's extended adjustment range.

Note: It is not easy to elongate the upper slot on AWD vehicles, use a right angle drill or SPC's remove and replace arm kit #67495 (below) for the 2003 - 06 Santa Fe.

Rear Adjustment range:
Camber $\pm 3.00^\circ$ Toe $\pm 1.50^\circ$

Required: 1 per wheel

APPLICATIONS

Hyundai: 2001 - 06 Santa Fe



85130 - Rotary File, pg 173

67495

SANTA FE ADJUSTABLE REAR ARM AND TOE CAM



Get $\pm 3.5^\circ$ of camber and $\pm 1.5^\circ$ of toe change on the rear of the 2003 to 2006 Hyundai Santa Fe by replacing the rear upper control arm. Use the included extended range cam bolt on the lower link to extend toe if needed. Use this kit's remove and replace control arm to replace a failed OE control arm and get the ability to dial in rear camber alignment for improved tire wear and drivability. Need change on an '01 or '02? Use cam kit p/n 67493 (above) to double the change provided by the OE cams.

Rear Adjustment range:
Camber $\pm 3.50^\circ$ Toe $\pm 1.50^\circ$

Required: 1 per wheel

APPLICATIONS

Hyundai: 2003 - 06 Santa Fe



85130 - Rotary File, pg 173

67510 67515

LEXUS REAR CAMBER KIT



This cam bolt and bracket kit provides an additional one degree of positive camber change. You will need to elongate the existing camber slot by using **85130** rotary files or equivalent. This is ideal for use on lowered vehicles along with our **67525** adjustable ball joint for front camber change (next page).



85130 - Rotary File, pg 173

Rear Adjustment range:
Additional Camber $+1.00^\circ$

Required: 1 per wheel

67510 APPLICATIONS

Lexus: 1998 - 05 GS; 2002 - 10 SC

67515 APPLICATIONS

Lexus: 2001 - 05 IS

Rear Adjustment range:
Camber. $\pm 1.50^\circ$

Required: 1 per wheel

APPLICATIONS

Lexus: 2006 - 11 GS; 2006 - 13 IS
2014 ISF
2014 - 15 IS Convertible

LEXUS IS & GS ADJ. REAR CAMBER ARM

SPC's tried and proven adjustable rear arms allow camber changes up to $\pm 1.5^\circ$ (Limited only by the toe cam's range). With the correct camber dialed in you can set up the popular Lexus IS and GS for superior handling and extended tire life.

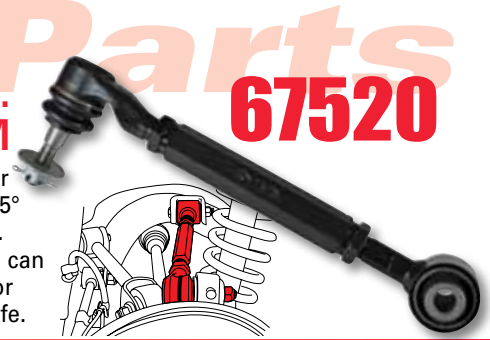

67520

Front Adjustment range:
Camber $\pm 1.50^\circ$

Required: 1 per wheel

67525 APPLICATIONS

Lexus: 2001 - 05 IS

67530 APPLICATIONS

Lexus:
2006 - 11 GS
2006 & Up IS



**40920 - Performance
Ball Joint Press,**
pg 165

LEXUS GS/IS BALL JOINT

Designed specifically for the Lexus GS & IS, this ball joint corrects camber up to $\pm 1.5^\circ$. With an OE quality replacement ball joint, this sliding plate assembly is perfect for vehicles that have been lowered for performance, or retain the factory ride height.



67525 67530

Rear Adjustment Range:
67540 (3 ARM SET)

Camber: $\pm 3.0^\circ$ /Toe: $\pm 3.0^\circ$ /
Setback: ± 1.0 "

67545 Camber: $\pm 1.0^\circ$

67550* Setback: ± 1.0 "

67555* Toe: ± 1.0 "

*** 67550 and 67555 MUST
be used with arm 67545**

Required: 1 per wheel

APPLICATIONS

Acura: 2015 & Up TLX AWD
2009 - 14 TL, TSX

Honda: 2008 - 17 Accord
2010 - 15 Crosstour

ACCORD/TSX REAR ADJUSTABLE 3 ARM SET

The Honda Accord and Acura TSX Rear Adjustable Control Arm Set (3) provides; $\pm 3^\circ$ camber adjustment (when using all 3 arms), additional toe change, and ± 1 " set-back / wheel base adjustment. Whether you need alignment changes to adjust for ride height changes, prepare for a weekend of road racing or correct suspension damage, this 3 piece arm set will provide maximum adjustability.

Attention: The sequence of arm adjustments made is extremely important when upgrading this multi-link system.

See the web for in-depth information on this kit and how it will work in the Accord/TSX multi-link suspension.

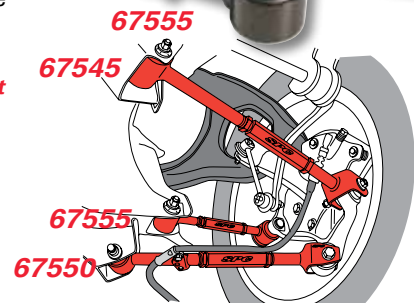

67540

Camber **67545**

Lateral **67550**

Toe **67555**

67545 - REAR CAMBER ARM

The Honda Accord and Acura TSX Adjustable Rear Camber Arm by itself allows camber change of up to $\pm 1^\circ$. If more than 1° change is required toe arm #67555 and lateral arm #67550 may be required. This single arm is also an ideal replacement arm for a damaged OE arm. Attention: Toe will change as you adjust camber with this control arm.

67550 - REAR LATERAL ARM

The Honda Accord and Acura TSX Rear Adjustable Trailing Arm is an ideal replacement for a damaged OE component. Additionally, it will provide ± 1 " set-back/wheel base adjustment. This arm is necessary to correct set-back changes that the 67545 adjustable camber arm and 67555 Adjustable Toe Arm will create when adjusting camber and toe beyond $\pm 1^\circ$.

67555 - REAR TOE ARM

The Honda Accord and Acura TSX Rear Adjustable Toe Arm is an ideal replacement for a damaged OE toe arm. Additionally, it provides added toe change beyond what the OE Toe Cam offers. This arm will be necessary to correct toe changes that the 67545 adjustable camber arm will create when adjusting beyond $\pm 1^\circ$.

Parts

67560

HONDA/ACURA ADJ. ARM AND CAM SET

Fully adjust rear camber, setback, and toe on many late model Honda and Acura vehicles with this alignment kit from SPC. This kit includes two (2) adjustable control arms and a toe cam bolt so you can compensate for ride height changes, enhance on-track performance, or correct for suspension damage. The 2015 & up FWD TLX uses a dynamic toe adjustment system that makes traditional suspension alignment difficult. Use this kit to dial in your rear alignment and take full advantage of your advanced suspension design.



Rear Adjustment range:
Camber $\pm 3.00^\circ$ Toe $\pm 2.50^\circ$

Required: 1 per wheel

APPLICATIONS

Acura: 2009 - 2014 TL, TSX
2015 & Up TLX
Honda: 2008 - 2017 Accord
2010 - 15 Crosstour



74920 - Punch, pg 170
85130 - Rotary File, pg 173

NEW
Specialty Products Company

Alignment Parts

Heavy Duty

NEW
Specialty Products Company

Racing/Builders

Tools

Brake and CV

Gear/Index

67565

HONDA/ACURA REAR TOE CAM

Extend your toe adjustment range on the rear of many popular Honda and Acura models. SPC's extended cam kit more than doubles the change available, you will be able to get $\pm 2.5^\circ$ toe change. This cam bolt features a hex chromate free finish that offers a 700hr salt spray test for the best corrosion protection available. One kit is used for each side of the vehicle. The OE slot will need to be extended to take advantage of the full range of SPC's cam. Use SPC slot punch p/n 74920, rotary file 85130, or similar.

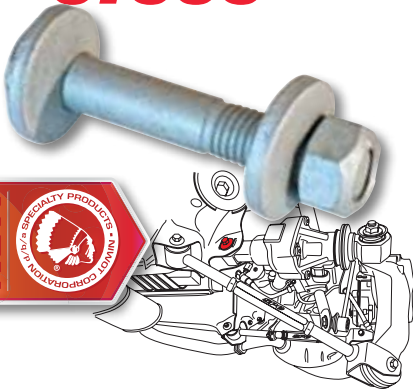

Rear Adjustment range:
Toe $\pm 2.50^\circ$

Required: 1 per wheel

APPLICATIONS

Acura: 2009 - 2014 TL, TSX
2015 & Up TLX
Honda: 2008 - 2017 Accord
2010 - 15 Crosstour



74920 - Punch, pg 170
85130 - Rotary File, pg 173

67570

HONDA REAR CAMBER ARMS

These adjustable rear upper control arms, for the Honda Pilot and Odyssey along with Acura MDX, ZDX, delivers 6° of camber change. The adjustable arm has OE style ball joint and bushing making it an ideal piece for both collision repair and traditional wheel alignment needs.

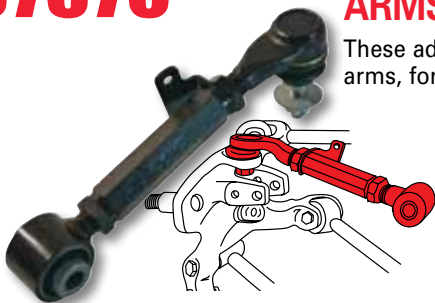

Rear Adjustment range:
Camber -2.00° to $+4.00^\circ$

Required: 1 per wheel

67570 APPLICATIONS

Acura: 2007 - 13 MDX
2010 - 13 ZDX
Honda: 2009 - 15 Pilot

67590

APPLICATIONS

Honda: 2005 - 17 Odyssey



67580

HONDA CR-V REAR ARM

These arms fit popular CR-Vs. By removing the stock upper rear control arm and replacing it with the adjustable arm you can adjust camber either positive or negative with the turnbuckle adjuster. This arm can be used on vehicles with stock ride height or vehicles that have been altered for performance.

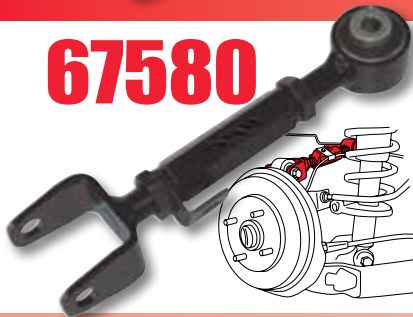

Rear Adjustment range:
Camber -2.00° to $+4.00^\circ$

Required: 1 per wheel

APPLICATIONS

Honda: 2007 - 16 CR-V

Race with SPC and the SCCA Solo Spec Coupe Class

The SCCA Solo Spec Coupe Class includes the Subaru BRZ and Scion FR-S. This class allows for some suspension modifications. Specialty Products' parts are approved for this class and include the Scion/Subaru Cam Bolts (#81305, page 118), the Adjustable Rear Camber Arm (#67660, page 100) and the Adjustable Rear Toe Arm (#67655, page 100).



2013-14 Subaru BRZ or Scion FR-S
• Small Sport Wheel modifications or temporary use
• Street-legal Performance Handling Package springs and adjustable air-ride
• SPC Performance Adjustable Rear B2 Control Arms, Adjustable Rear Control Arms, and Toe Arms
*Note: Performance Handling Package modifications are not allowed.

Rear Adjustment range:
Camber $\pm 2.00^\circ$ Toe $\pm 2.00^\circ$

Required: 1 per wheel

APPLICATIONS

Acura: 2007 - 18 RDX



85130 - Rotary File, pg 173

ACURA ADJUSTABLE REAR ARM AND CAM

67595

Make rear camber adjustable on the Acura RDX with this adjustable upper control arm and replacement toe cam bolt kit from SPC. The adjustable rear lower control arm will provide $\pm 2.0^\circ$ camber and the extended range OE replacement toe cam will allow you to bring toe back into specification with $\pm 2.0^\circ$ of change. This is the kit you need to improve handling or decrease tire wear issues. Use rotary file #85130 to extend the factory toe slot and take advantage of the full change provided by the toe cam bolt.

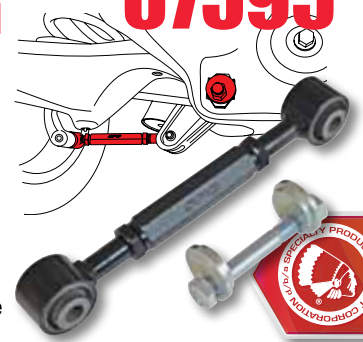

Rear Adjustment range:
Toe $\pm 2.00^\circ$

Required: 1 per wheel

APPLICATIONS

Acura: 2007 - 18 RDX



85130 - Rotary File, pg 173

RDX REAR TOE CAM

67596

Double the change provided by the OE toe cam with this replacement cam from SPC. Use this kit to take advantage of a full $\pm 2^\circ$ adjustment or simply to replace corroded and damaged toe cams on the Acura RDX. Depending on how much change you need, you may need to use rotary file #85130 to extend the factory toe slot and take full advantage of the extended range on this cam bolt.

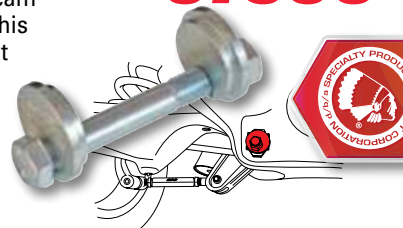

Rear Adjustment range: Camber $\pm 4.00^\circ$
Required: 1 per axle

APPLICATIONS

Mini Cooper: 2009 - 15 Convertible
2008 - 14 Clubman; 2011 - 16 Countryman
2012 - 15 Coupe (Incl. Roadster)
2002 - 13 Hardtop; 2013 - 16 Paceman

MINI COOPER REAR CAMBER ARM (PR)

67610

These billet aluminum arms are a great camber solution for these tuner vehicles. In a beautiful silver anodized finish with SPC "Red" nuts, these arms give you a full $\pm 4.0^\circ$ of rear camber change.



87566 - MINI Rear Toe Adjusting Tool, pg 174



Front Adjustment range:
Camber $\pm 2.00^\circ$ Caster $\pm 0.75^\circ$

Required: 1 per axle



67620 APPLICATIONS

Mini Cooper: 2004 - 08 Convertible
2002 - 06 Hardtop

67630 APPLICATIONS

Mini Cooper: 2009 - 15 Convertible
2008 - 14 Clubman; 2011 - 16 Countryman
2012 - 15 Coupe (Incl. Roadster)
2002 - 13 Hardtop; 2013 - 16 Paceman

MINI COOPER FRONT STRUT MOUNT (PR)

67620

67630

Crafted from aircraft quality aluminum, these precision machined adjusters feature OE style bearings and a bonded urethane insulator.

Tuners will find this kit, with its ability to change both camber and caster, perfect for both performance and racing applications.



72095 - pg 169 - Use this tool for struts with adjustable damping



Rear Adjustment range:
Camber $\pm 1.5^\circ$ Toe $\pm 1.5^\circ$

Required: 1 per wheel

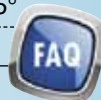

APPLICATIONS

Subaru: 1993 - 07 Impreza
WRX, STi
1990 - 99 Legacy, Outback
1992 - 97 SVX
Saab: 2005 - 07 9-2X

SUBARU/SAAB EZ ARM XR™ (PR)

67640

This set of 2 adjustable lower control arms will provide up to $\pm 1.5^\circ$ of additional camber and toe adjustment for all 1993 - 07 Imprezas, STis and WRXs as well as Saab 9-2Xs. Especially designed for the performance enthusiast, these arms can be used on lowered or stock ride height vehicles.

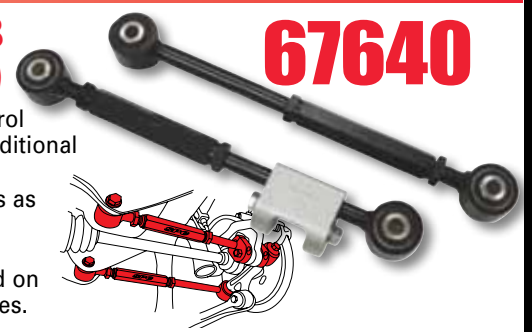

Parts

Applications

Alignment Parts

Heavy Duty

OE Replacement

Racing/Builders

Tools

Brake and CV

Gear/Index

67655

SUBARU/SCION ADJ. REAR TOE ARM

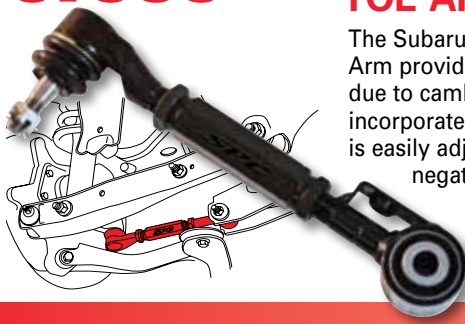

The Subaru Adjustable Rear Toe EZ Arm provides maximum toe change required due to camber changes. The toe arm incorporates an integrated OE style ball joint and is easily adjusted for positive or negative toe.

Rear Adjustment range: Toe $\pm 3.0^\circ$
Required: 1 per wheel

APPLICATIONS

- Scion:** 2013 - 16 FR-S
- Subaru:** 2013 & Up BRZ
2009 & Up Forester
2010 & Up Legacy, Outback
2008 - 16 Impreza
2008 & Up WRX (Inc. STi)
2012 & Up XV CrossTrek
- Toyota:** 2017 & Up 86

67660

SUBARU/SCION ADJ. REAR CAMBER ARM AND TOE KIT

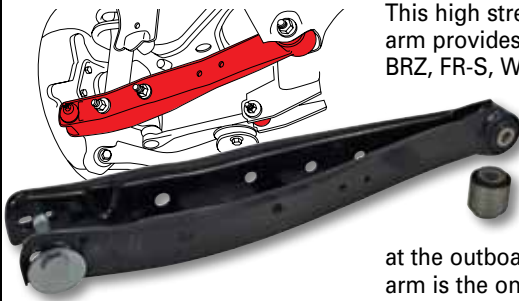

This high strength adjustable lower rear camber arm provides $\pm 2.0^\circ$ of change for the popular BRZ, FR-S, WRX and Impreza. Get the ultimate in performance and handling with this stamped arm featuring our new xAxis™ Sealed Flex Joint which performs like a pillow joint but lasts like an OE joint. This kit is easy to adjust with a cam located at the outboard side of the arm. SPC's control arm is the only kit on the market to include an offset toe bushing to increase the range of your factory cam. If you need more toe consider SPC's toe arm #67655 (above).

Rear Adjustment range:
Camber $\pm 2.0^\circ$ Toe 1.5° Fixed
Required: 1 per wheel

APPLICATIONS

- Scion:** 2013 - 16 FR-S
- Subaru:** 2013 & Up BRZ
2009 & Up Forester
2010 & Up Legacy, Outback
2008 - 16 Impreza
2008 & Up WRX (Inc. STi)
2012 & Up XV CrossTrek
- Toyota:** 2017 & Up 86

- 67647 - Bushing Sleeves, pg 168**
- 72509 - Ball Joint Press, pg 169**



67665

SUBARU ADJUSTABLE CAMBER ARM

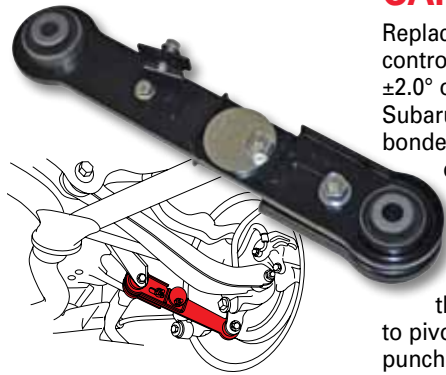

Replace the factory non-adjustable rear lower control arm with this adjustable arm to dial in $\pm 2.0^\circ$ of rear camber on many early 2000's Subarus. This remove and replace arm has bonded rubber bushings to match chassis design parameters and includes the ride height sensor bracket that is needed on some applications. Because of the constraining 5-link suspension design, you will need to slot the frame bracket on the upper control arm to allow the knuckle to pivot for camber change. SPC recommends punch #79440 to make the job quick and easy.

Rear Adjustment range:
Camber. $\pm 2.00^\circ$
Required: 1 per wheel

APPLICATIONS

- Subaru:** 2003 - 06 Baja
2000 - 09 Legacy
2000 - 09 Outback
- Patent No. US 8,746,714

- 74940 - Punch Tool, pg 170**
- 85125 Rotary File pg 173**

67667 67668

SUBARU ADJUSTABLE REAR TOE KIT

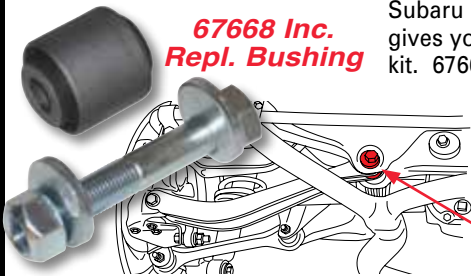

67668 Inc. Repl. Bushing

Need to replace corroded or damaged OE toe cam bolts on the rear of the 2000 to 2009 Subaru Legacy, Outback and many more? SPC gives you options. 67667 is a replacement cam kit. 67668 includes a replacement bushing. Get up to $\pm 1.5^\circ$ of toe change and then lock it in place with these economical options. One kit is required per side or two for the entire vehicle.

67668 Replacement Bushing Location

Rear Adjustment range:
67667 Toe $\pm 1.50^\circ$
Required: 1 per wheel

67668 Toe $\pm 1.50^\circ$
Includes Repl. Rubber Bushing

Required: 1 per wheel

APPLICATIONS

- Subaru:** 2003 - 06 Baja
2000 - 09 Legacy
2000 - 09 Outback
2006 - 10 Tribeca

Rear Adjustment range:
Camber $\pm 2.00^\circ$

Required: 1 per wheel

APPLICATIONS

Ford: 2013 & Up Fusion
Lincoln: 2013 & Up MKZ

Patent No. US 8,746,714

FUSION ADJUSTABLE REAR CONTROL ARM

67680

Add $\pm 2.0^\circ$ of camber adjustment to the rear suspension of your '13+ Ford Fusion or Lincoln MKZ with these fully adjustable rear control arms. The arm includes SPC's xAxis™ Sealed Flex joint for improved durability and minimized deflection providing improved handling performance.



Rear Adjustment range:
Camber ± 1.25

Required: 1 per wheel

APPLICATIONS AWD ONLY

Ford: 2005 - 07 Five Hundred
2005 - 07 Freestyle
2008 - 09 Taurus
2008 - 09 Taurus X
Mercury: 2005 - 07 Montego
2008 - 09 Sable

OE Replacement ball joint available - #12710, page 151.

FORD REAR BALL JOINT

67690

Use this adjustable ball joint to get $\pm 1.25^\circ$ camber change on Ford's D3 Platform AWD vehicles like the Five Hundred, Taurus, Sable, Freestyle, and Taurus X from 2005 - 2009. Many of these vehicles develop negative camber in the rear, but there is no factory correction. To get change, you will need to press the OE ball joint out of the knuckle and replace it with this adjustable offset stud design from SPC. Once loosely reassembled, you will be able to easily turn the 8mm hex on the stud and watch camber change. SPC recommends a shop press to press out and in the old and new ball joints.



Front Adjustment range:
Caster $\pm 1.5^\circ$

Required: 1 per axle

APPLICATIONS

Nissan: 1989 - 98 240SX

FRONT CASTER ROD (PR)

240SX Alignment Kits

67720

These replacement front adjustable strut rods are easily adjustable and give these popular tuner vehicles the ability to change caster by 3° . A stiffer rubber bushing material provides better handling in performance applications.



Rear Adjustment range: Toe $\pm 2.0^\circ$

Required: 1 kit per wheel

APPLICATIONS

Nissan: 1989 - 98 240SX

TOE LINK

67740

This adjustable arm increases the amount rear toe can be changed on this popular performance vehicle. It is recommended that this arm be installed when either the 67765 or the 67775/ 67776 (below) is being installed.



Rear Adjustment range:
Camber $\pm 3.0^\circ$ (2 Arm Set)

Required: 1 per wheel

67765 APPLICATIONS

Left or Right

Nissan: 1989 - 94 240SX
1990-96 300ZX

67775 Left

67776 Right

Nissan: 1995 - 98 240SX

REAR CAMBER KITS

These rear arms provide an increased amount of camber change on these popular tuner cars. Two arms are required per side and are adjusted together to give the maximum amount of camber change without affecting wheel setback. Stiffer rubber bushing material is used for better handling in performance applications.

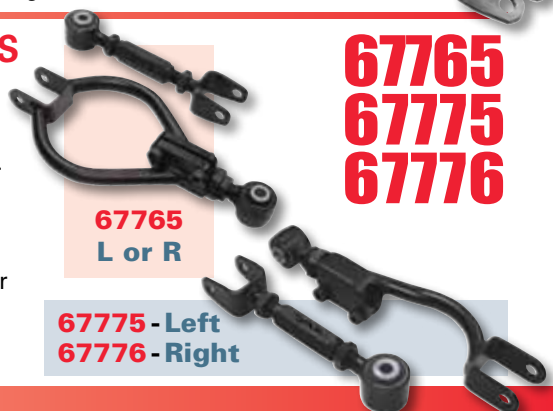

67765

67775

67776

67765
L or R

67775 - Left
67776 - Right

Rear Adjustment range:
Toe $\pm 3.0^\circ$

Required: 1 per wheel

APPLICATIONS

Lexus: 2011 - 17 CT; 2010 - 12 HS
Scion: 2016 - 16 iM; 2011 - 16 tC
Toyota 2017 - 18 Corolla iM

SCION/LEXUS TOE ARM

67800

Extend total toe change on select Scion, Lexus, and Toyota models with SPC's replacement rear toe adjustment arm. Many of these models come with factory adjustment but need more due to factory recalls, lowering, or collision repair. SPC's remove and replace rear link provides $\pm 3.0^\circ$ of toe change.

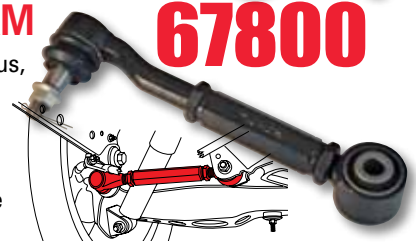

67806

TOYOTA RAV4 REAR ADJUSTABLE TOE ARM

Due to a factory recall for Toyota RAV4's, much of the third generation of this popular platform no longer has provisions for rear toe adjustment. Replace Toyota's non-adjustable rear arm with SPC's adjustable link and get the toe changes needed to avoid premature tire wear. SPC's R&R rear link provides $\pm 3.0^\circ$ of toe change.

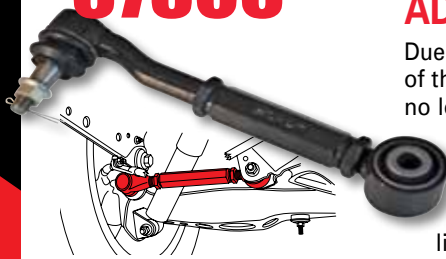

Rear Adjustment range:
Toe $\pm 3.00^\circ$

Required: 1 per wheel

APPLICATIONS

Toyota: 2006 - 18 RAV4

67810 RIGHT SIDE

67811 LEFT SIDE

RAV4 ADJ. CAMBER ARM

Adjust rear camber on late model RAV4 and Lexus NX200t with this adjustable rear camber arm. With $\pm 3^\circ$ of adjustment, this arm will get your vehicle back into factory specification to ensure proper tire wear, handling, and ride quality. Use part number 67810 for the right hand side or part number 67811 for the left hand side of the rear suspension.



Rear Adjustment range:
Camber $\pm 3.00^\circ$

Required: 1 per wheel

APPLICATIONS

Toyota:
2006 - 18 RAV4
Lexus:
2015 & Up NX

Patent No. US 8,746,714

69300 69400

HONDA/ACURA REAR CLEARANCE ARMS (PR)

These extreme lower control arms are for Honda Civics and Acura RSXs. Made from aircraft aluminum alloy, these arms are available in a silver finish.

When teamed up with front and rear camber arms SPC Performance provides you with a complete alignment solution when lowering your Civic or RSX.



It is recommended that a toe adjuster (below) be used with these arms.

Rear Adjustment range:

Note: These arms are for appearance and weight saving only. They include a special Socket, Part 69330 (page 168) which is required for installation

Required: 1 per axle

69300 APPLICATIONS

Acura: 2001 - 05 EL
Honda: 2001 - 05 Civic

69400 APPLICATIONS

Acura: 2002 - 06 RSX
Honda: 2002 - 06 CR-V
2003 - 11 Element

69450

HONDA/ACURA TOE ADJUSTER (PR)

These great looking kits adjust toe with a polished aluminum red finish. May be used alone, however a toe adjuster should be used with Clearance Arms #69300 and #69400 (above).



Rear Adjustment range:
Toe $\pm 2.00^\circ$

Required: 1 per axle

APPLICATIONS

Acura: 1997 - 00 EL
1990 - 01 Integra
Honda: 1992 - 00 Civic
1997 - 01 CR-V
1992 - 97 Del Sol

71000 SERIES

FULL CONTACT REAR SHIMS

These full contact rear shims will correct camber and/or toe. Combination adjustments, or changes up to 1.0° may be achieved by using 2 shims on each wheel.

71000 SHIM SET
Includes 12 shims/2 each size

CAMBER/TOE Part No.	Change
71020	.06°
71021	.13°
71022	.25°
71023	.38°
71024	.50°
71025	.75°



NOTE:
Do NOT adjust Camber or Toe over 1.0°

Rear Adjustment range:
Camber $\pm 1.00^\circ$ /Toe $\pm 1.00^\circ$

Required: 1 shim per wheel/
per angle changed

APPLICATIONS

Toyota FWD: 1998 - 10 Sienna
Nissan FWD: 2011 - 17 Juke
2011 - 17 Leaf

Rear Adjustment range:
Camber $\pm 1.00^\circ$ / Toe $\pm 1.00^\circ$

Required: 1 or 2 per wheel

71030 Series APPLICATIONS

Buick: 2012 - 17 Verano
Cadillac: 2014 - 16 ELR
Chevrolet: 2011 & Up Cruze
2011 & Up Volt

71050 Series APPLICATIONS

Buick FWD: 2013 & Up Encore
Chevrolet FWD: 2012 & Up Sonic
2015 & Up Trax

71030 SHIM SET

Includes 18 shims/
2 each of
71031-71035 and
71041-46

71050 SHIM SET

Includes 18 shims/
2 each of
71051-71055 and
71061-71066

GM REAR TOE AND CAMBER SHIMS

Make rear wheel alignment changes on these twist beam axles with SPC's stackable fixed change shims. Change camber in $\pm .25^\circ$ increments and toe in $\pm .10^\circ$ increments. Combine a toe shim with a camber shim to get the exact change required. Stack up to two shims for maximum change.

71030 SERIES	TOE	Change	CAMBER	Change
71031	$\pm 10^\circ$	$\pm 10^\circ$	71041	+ .25°
71032	$\pm 20^\circ$	$\pm 20^\circ$	71042	+ .50°
71033	$\pm 30^\circ$	$\pm 30^\circ$	71045	- .25°
71034	$\pm 40^\circ$	$\pm 40^\circ$	71046	- .50°
71035	$\pm 50^\circ$	$\pm 50^\circ$		

71050 SERIES	TOE	Change	CAMBER	Change
71051	$\pm 10^\circ$	$\pm 10^\circ$	71061	+ .25°
71052	$\pm 20^\circ$	$\pm 20^\circ$	71062	+ .50°
71053	$\pm 30^\circ$	$\pm 30^\circ$	71065	- .25°
71054	$\pm 40^\circ$	$\pm 40^\circ$	71066	- .50°
71055	$\pm 50^\circ$	$\pm 50^\circ$		

71030 SERIES

71050 SERIES



Rear Adjustment range:
Toe $\pm .50^\circ$

Required: 1 or 2 per wheel

APPLICATIONS

Hyundai: 2012 - 17 Accent
Kia: 2012 - 17 Rio

CAUTION: Do NOT stack this shim.
* Includes brake caliper shim

RIO/ACCENT REAR SHIMS

TOE Part No.	Change
71071	$\pm 13^\circ$
71072	$\pm 25^\circ$
71073	$\pm 38^\circ$ *
71074	$\pm 50^\circ$ *

71070 SHIM SET Includes 8 shims/2 each size

The twist beam axle on the rear of the Kia Rio and Hyundai Accent does not give you any method to adjust toe. Correct toe and thrust angle issues to improve drivability and increase tire life with these full contact shims.

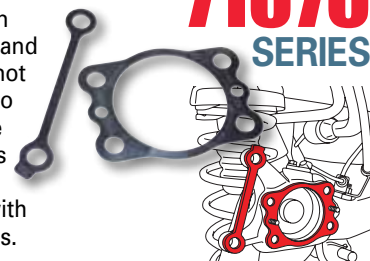

71070 SERIES

Rear Adjustment range:
Camber $\pm .50^\circ$ to $\pm 1.00^\circ$ /
Toe $\pm .13^\circ$ to $\pm .50^\circ$

Required:

1 shim per wheel/per angle changed

APPLICATIONS

Audi FWD: 2000 - 06 TT
Volkswagen: 1998 - 10 Beetle
1999 - 06 Golf (Except R32)
1999 - 06 GTI
1999 - 05 Jetta (Beam Rear Axle)

CAUTION: Check brake & rotor clearance for binding. 75970 spacers (page 116) maybe required.

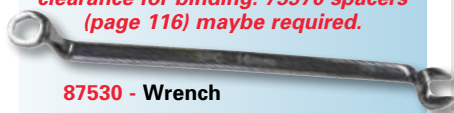

87530 - Wrench

VW/AUDI REAR SHIMS

With these shims you can correct rear camber and toe on newer Volkswagens and Audis. By combining the shims (two may be used on each wheel) you can get $\pm .50^\circ$ to $\pm 1.0^\circ$ camber change and up to $\pm .50^\circ$ toe change. Our wrench

TOE Part No.	Change
71520	$\pm 13^\circ$
71521	$\pm 25^\circ$
71522	$\pm 38^\circ$
71523	$\pm 50^\circ$

CAMBER	Change
71530	+ .50°
71531	+ 1.00°
71532	- .50°
71533	- 1.00°

(87530) is a must when installing these shims. It allows you to remove the brake sensor ring, bearing, seal and hub assembly as one unit.

71500 SHIM SET Includes 16 shims/2 of each size and 87530 wrench.

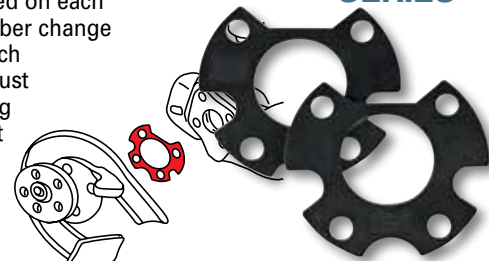

NOTE: When installing these shims we recommended that you use our VW Shim Wrench (#87530 pg. 174) to assist in removing the rear hub.

71500 SERIES

Rear Adjustment range:
Camber $\pm .25^\circ$ and $\pm .50^\circ$
Toe $\pm .10^\circ$ to $\pm .50^\circ$

Required: 1 or 2 shims per wheel

APPLICATIONS

Toyota AWD/FWD:
2011 & Up Sienna

71600 SHIM SET

- Includes 14 shims/2 of each size.

TOYOTA SIENNA REAR CAMBER AND TOE SHIMS

TOE Part No.	Change
71621	$\pm 10^\circ$
71622	$\pm 20^\circ$
71623	$\pm 30^\circ$
71624	$\pm 40^\circ$
71625	$\pm 50^\circ$

CAMBER	Change
71631	$\pm 25^\circ$
71632	$\pm 50^\circ$

These full contact shims correct camber and/or toe on both AWD and FWD Toyota Siennas. Combination adjustments, or changes up to 1° may be made by stacking up to 2 shims per side.



71600 SERIES

Parts

71700 SERIES



CHRYSLER MINI-VAN SHIMS

For camber and toe change, use our mini-van shims that allow for quick and easy changes in increments of: toe .10° and camber .25°.

71740 SHIM SET - Includes 20 shims/2 of each size

TOE Part No.	Degree of Change
71720	±10° [.05" (1/16")]
71721	±20° [.10" (1/8")]
71722	±30° [.15" (5/32")]

Part No.	Degree of Change
71723	±40° [.20" (3/16")]
71724	±50° [.25" (1/4")]
71725	±80° [.40" (3/8")]

CAMBER Part No.	Degree of Change
71730	±25° (1/4°)
71731	±50° (1/2°)
71732	±75° (3/4°)
71733	±00° (1°)

Rear Adjustment range:
Camber ±1.00°/Toe ±.10° to ±.80°

Required: 1 shim per wheel/
per angle changed

APPLICATIONS

Chrysler 1996 - 16 Town & Country
FWD: 2000 - 03 Voyager
Dodge 1996 - 07 Caravan
FWD: 1996 & Up Grand Caravan
Ram 2012 - 15 Tradesman
FWD: Conversion Van
Nissan: 2007 -12 Sentra
Plymouth FWD: 1996 - 01 Voyager
Volkswagen FWD: 2009 - 14 Routan

Applications

Alignment Parts

Heavy Duty

OE Replacement

Racing/Builders

Tools

Brake and CV

Gear/Index

71740 SERIES



PT CRUISER REAR CAMBER AND TOE SHIMS

This easy to install full contact shim is perfect for PT Cruisers needing rear camber or toe adjustment. SPC's fixed change shims will provide ±.10° to ±.50° of toe change and ±.25° to ±1.00° camber change and can be stacked up to two shims.

71740 SHIM SET - Includes 22 shims/2 of each size

TOE Part No.	Degree of Change	Part No.	Degree of Change
71741	±.10°	71744	±.40°
71742	±.20°	71745	±.50°
71743	±.30°		

CAMBER Part No.	Degree of Change	Part No.	Degree of Change
71751	+.25°	71755	-.25°
71752	+.50°	71756	-.50°
71754	+1.00°	71758	-1.00°

Rear Adjustment range:
Camber ±.25°, ±.50°, ±1.00°
Toe ±.10 to ±.50°

Required: 1 or 2 shims per wheel

APPLICATIONS

Chrysler: 2001 - 10 PT Cruiser

71760 SERIES



FORD REAR CAMBER SHIM TAURUS/FREESTYLE

This full contact rear shim adds positive 0.5°, .75°, or 1.0°, camber to minimize camber related tire wear for 08-09 Ford Taurus and 05-07 Ford Freestyle FWD. Brake caliper shim included for correct hub to caliper alignment.

71760 SHIM SET
Includes 6 shims/2 of each size.

CAMBER Part No.	Change
71762	+.50°
71763	+.75°
71764	+1.00°

Rear Adjustment range:
Camber +.50°, +.75°, +1.00°

Required: 1 or 2 shims per wheel

APPLICATIONS

Ford FWD: 2005 - 07 Five Hundred
 2005 - 07 Freestyle
 2008 - 09 Taurus
 2008 - 09 TaurusX
Mercury FWD:
 2005 - 07 Montego
 2008 - 09 Sable FWD

71770 SERIES

71780 SERIES



Note: You will need inverted (female) torx socket E20 to remove the hub.

FIAT REAR CAMBER AND TOE SHIMS

Bring toe and camber back to factory specification on the rear of the Fiat 500 with these fixed change shims from SPC. The 24 piece set includes two each of the toe shims that will adjust from -.5° to +.5° in 1/8° increments and camber shims that will adjust from ±.25° to ±1.0° in 1/4° increments. Combine up to two shims to dial in both toe and camber. Shims are also available individually. Fix tire wear issues and return proper handling.

TOE Part No.	Degree of Change	Part No.	Degree of Change	CAMBER Part No.	Degree of Change
71771	+.13°	71776	-.13°	71781	±.25°
71772	+.25°	71777	-.25°	71782	±.50°
71773	+.38°	71778	-.38°	71783	±.75°
71774	+.50°	71779	-.50°	71784	±1.00°

Rear Adjustment range:
Camber ±.25°, ±.50°, ±.75°, ±1.00°
Toe ±.13 to ±.50° (1/8° increments)

Required: 1 shim per wheel/
per angle changed

APPLICATIONS

Fiat: 2012 & Up 500

71770 SHIM SET

Includes 26 shims/2 each of each size.

Rear Adjustment range:
 Camber $\pm 25^\circ$, $\pm 50^\circ$, $\pm 75^\circ$, $\pm 1.00^\circ$
 Toe ± 10 to $\pm 50^\circ$ (.10° increments)
 Required: 1 shim per wheel/
 per angle changed

APPLICATIONS

Honda: 2015 - 19 Fit

71790 SHIM SET

Includes 18 shims/2 of each size

HONDA REAR CAMBER AND TOE SHIMS

Bring toe and camber back to factory specification on the rear of the Honda Fit with these fixed change shims from SPC. This 18 piece kit includes two each of the toe shims that will adjust from $\pm 0.1^\circ$ to $\pm 0.5^\circ$ in $1/10^\circ$ increments and camber shims that will adjust from $\pm 0.25^\circ$ to $\pm 1.0^\circ$ in $1/4^\circ$ increments. Combine up to two shims to dial in both toe and camber. Fix tire wear issues and return proper handling.

71790 SERIES

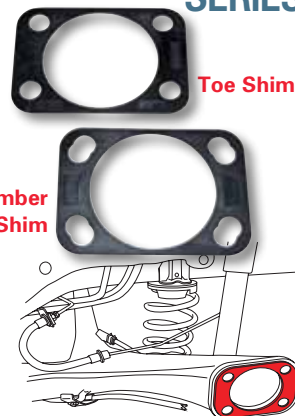

TOE	
Part No.	Change
71791	$\pm 10^\circ$
71792	$\pm 20^\circ$
71793	$\pm 30^\circ$
71794	$\pm 40^\circ$
71795	$\pm 50^\circ$

CAMBER	
Part No.	Change
71796	$\pm 25^\circ$
71797	$\pm 50^\circ$
71798	$\pm 75^\circ$
71799	$\pm 1.00^\circ$

Rear Adjustment range:
 Camber $\pm 50^\circ$, $\pm 1.0^\circ$
 Toe $\pm 50^\circ$, $\pm 1.0^\circ$

Required: 1 shim per wheel

APPLICATIONS

Nissan: 2012 - 19 Versa, inc. Note

71860 SHIM SET

Inclues 4 shims/2 of each size.

NISSAN VERSA CAMBER AND TOE SHIMS

Adjust front camber on the Nissan Versa with these fixed change, full contact shims from SPC. Combine up to two shims to dial in both toe and camber. Fix tire wear issues and return proper handling with these easy to install shims.

71860 SERIES



CAMBER & TOE	
Part No.	Change
71861	$\pm 50^\circ$
71862	$\pm 1.00^\circ$

Front Adjustment range:
 Camber $\pm 50^\circ$, $\pm 75^\circ$, $\pm 1.0^\circ$, $\pm 1.25^\circ$
 Required: 1 shim per wheel

APPLICATIONS

Hyundai: 2009 - 14 Genesis Sedan
 2011 - 13 Equus

Kia: 2015 K900

71930 SHIM SET

Inclues 8 shims/2 of each size.

HYUNDAI CAMBER SHIM

Adjust front camber on the Hyundai Genesis Sedan with these aluminum full contact shims from SPC. Whether you want negative camber for the track or positive change to reduce tire wear, these easy to install aluminum shims will get the job done.

71930 SERIES

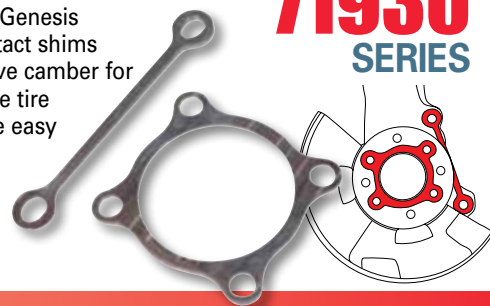

CAMBER	
Part No.	Change
71932	$\pm 50^\circ$
71933	$\pm 75^\circ$
71934	$\pm 1.00^\circ$
71935	$\pm 1.25^\circ$

Front Adjustment range:
 Camber $\pm 2.00^\circ$ Caster $\pm 2.00^\circ$

Installation time: 1.0 hr/side

Required: 1 per axle

APPLICATIONS

Ford: 2005 - 10 Mustang

Note: We do not recommend the use of caster/ camber plates on coil-over equipped vehicles.

Note: Modification of the strut tower opening will be necessary to gain access to adjusting bolts.

MUSTANG FRONT CAMBER/CASTER STRUT MOUNT (PR)

Get 4° of camber and caster change on the 2005 to 2010 Ford Mustang with this pair of adjustable upper strut mounts. By mounting the OE strut bearing and spring seat on SPC's adjustable plate you get the change you need without affecting ride height. Whether you need to get your alignment angles back in specification for drivability and tire wear after ride height modifications or are getting ready for the track, this is the kit for you. Need more change? Check out p/n 72350 (pg 111).

72040



Parts

72045

MUSTANG ADJUSTABLE PANHARD BAR

Complete your suspension tuning project plus get additional pinion and thrust angle adjustments by using SPC's adjustable trailing arms #72345 (page 111)

SPC aluminum panhard bars provide weight savings and adjustability! Manufactured from aircraft grade aluminum, precision machined, and then black e-coated, the SPC panhard bar is the lightest durable unit on the market. High durometer, same sized, vulcanized rubber bushings promote precise handling while maintaining factory noise levels and damping qualities. Adjust your Mustang SPC panhard bar on the car to optimize lateral stability and tracking.

Rear Adjustment range:
Tracking $\pm 1.5^\circ$

Required: 1 per axle

APPLICATIONS

Ford: 2005 - 14 Mustang

Rear Adjustment range:
Camber $\pm 3.00^\circ$ Toe $\pm 2.00^\circ$

Required: 1 per wheel

APPLICATIONS

Infiniti: 2003 - 07 G35 Coupe
w/o rear active steer
2003 - 06 G35 Sedan

Nissan: 2003 - 08 350Z
2002 - 06 Altima
2004 - 14 Maxima



72050

NISSAN/INFINITI EXTREME REAR CAMBER/TOE KIT

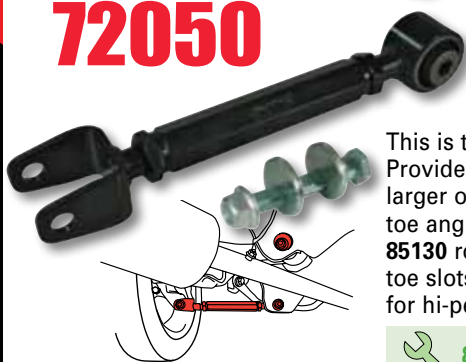

This is the perfect kit for lowered Z or G35. Provides additional camber and comes with a larger offset toe cam to bring the toe angle back into range. Use the **85130** rotary file set to elongate the toe slots. See part #72052 (below) for hi-performance arms.



85130 - Rotary File Set, pg 173

72052

NISSAN/INFINITI PERFORMANCE REAR CAMBER/TOE KIT AND LOCKING PLATES (PR)

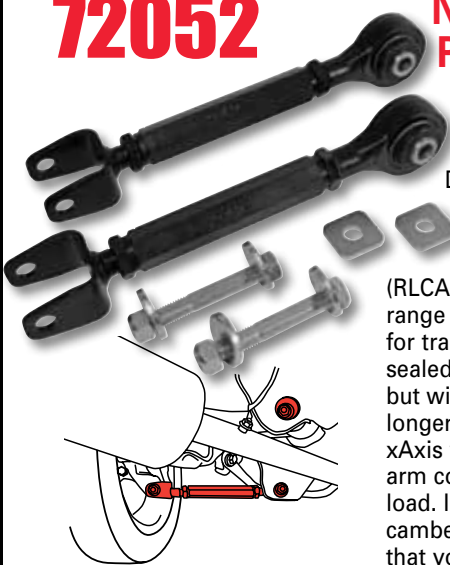

Dial in $\pm 3.0^\circ$ camber and $\pm 2.0^\circ$ of toe to maximize your suspension set-up on the 350Z and G35 with this set of race ready adjustable rear lower control arms (RLCA), camber lockout plates, and extended range toe cams from SPC. Specifically designed for track use, these arms include SPC's xAxis™ sealed flex joints that perform like monoballs, but with non-metal bushings which will last longer than OE bushings. These arms combine xAxis with forged steel receivers and straight-arm construction to minimize compliance under load. Included lockout plates will replace the OE camber cams to give you that extra assurance that your camber is locked in.

Rear Adjustment range:
Camber $\pm 3.00^\circ$ Toe $\pm 2.00^\circ$

Required: 1 per axle

APPLICATIONS

Infiniti: 2003 - 07 G35 Coupe
w/o rear active steer
2003 - 06 G35 Sedan

Nissan: 2003 - 08 350Z
2002 - 06 Altima
2004 - 14 Maxima



85130 - Rotary File Set, pg 173

See page 110 and 111 for additional rear arms for Nissans and Infinitis

72055

NISSAN/INFINITI REAR CAMBER/TOE KIT (PR)



These cams (set of 2) replace the OE camber and toe adjustment cams and provide additional camber and toe changes. Adjustment slots will need to be elongated using **85130** rotary file set or equivalent.



85130 - Rotary File Set, pg 173

Rear Adjustment range:
Camber $\pm 2.00^\circ$
Toe $\pm 2.00^\circ$

Required: 1 per wheel

APPLICATIONS

Infiniti: 2003 - 07 G35 Coupe
w/o rear active steer
2003 - 06 G35 Sedan

Nissan: 2003 - 08 350Z
2007 - 13 Altima Coupe
2002 - 12 Altima Sedan
2004 - 14 Maxima



Front Adjustment range:
Camber -0.50° to $+1.50^{\circ}$
Caster 0.0° to $+1.50^{\circ}$

Required: 1 per axle



APPLICATIONS

Ford: 1994 - 04 Mustang

Note: We do not recommend the use of caster/ camber plates on coil-over equipped vehicles.

MUSTANG FRONT CAMBER/CASTER STRUT MOUNT (PR)

This pair of adjustable strut mounts feature polyurethane bushings for quiet operation and maximum performance, and are CNC machined from 6061 heat treated aluminum. The TIG welded strut hats increase strut travel which is especially important on lowered cars. Complete with special strut boots and bump stops.

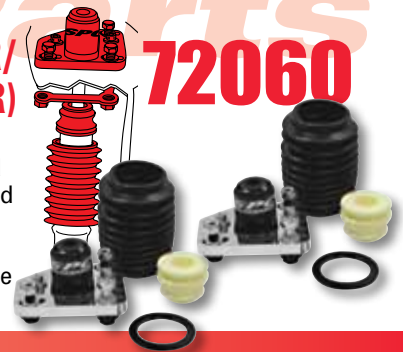

72060

Front Adjustment range:
Camber -1.00° to $+3.00^{\circ}$
Caster $\pm 0.50^{\circ}$

Required: 1 per axle



APPLICATIONS

72065 BMW RWD: 1984 - 91 3 Series (E30)

72070 BMW 2008 - 13 1 Series (E81, E82, E87, E88)
AWD: 2007 - 13 3 Series (E92, E93)
2006 - 12 3 Series Sed./Wag. (E90, E91)

BMW 1992 - 99 3 Series 318, 325, 328, M3 (E36)
RWD: 1996 - 02 Z3 Coupe/Rdstr - Incl. 'M' (E36)

72080 BMW 2000 - 04 3 Series Coupe/Conv. (E46)
RWD/AWD: 1999 - 03 3 Series Sedan/Wagon (E46)

BMW 1996 - 03 5 Series 525i, 528i w/o EDC,
RWD: 528iT, 530i (E39)

72090 BMW 2004 - 05 3 Series Sedan/Wagon (E46)
RWD/AWD: 2005 - 06 3 Series Coupe/Conv. (E46)

BMW 2003 - 08 3 Series Z4 - Except 'M' (E85)
RWD: 1992 - 99 3 Series 318Ti (E30)

See page 108 for additional adjustable front strut mounts for RWD 1 & 3 Series and more

BMW FRONT ADJUSTABLE UPPER STRUT MOUNTS (PR)

Engineered utilizing a unique, multi-adjustable design, this strut mount pair fits a wide variety of BMWs.

Crafted from aircraft quality aluminum, these precision machined adjusters feature OE style bearings and a bonded urethane insulator. Tuners will find this kit's ability to change both camber and caster, perfect for both performance and racing applications.

Not recommended for aftermarket coil-over equipped vehicles.

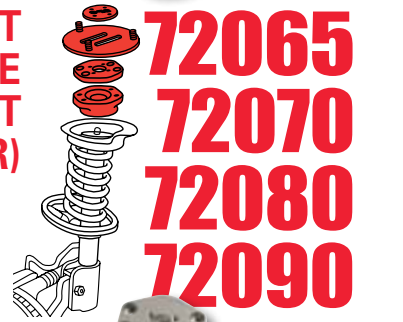

72065

72070

72080

72090

72095 - pg 169 - Use this tool for struts with adj. damping

Rear Adjustment range:
Camber -1.00° to $+3.00^{\circ}$

Required: 1 per axle

APPLICATIONS

BMW: 2000 - 06 3 Series Coupe and Convertible (E46)
1999 - 05 3 Series Sedan and Wagon (E46)
1992 - 99 3 Series 318, 323 and M3 (E36)
2003 - 08 3 Series Z4 (E85)

BMW REAR LOWER CONTROL ARM (PR)

These billet aluminum arms fit the 3-Series along with the Z4, giving you -1.0° to $+3.0^{\circ}$ of rear camber change. Great for tuner vehicles, these machined parts are in a stand-out silver anodized finished with SPC "Red" nuts. See page 89 for our standard EZ Arm (#67110).



87565 - Rear Toe Adjusting Tool, pg 174

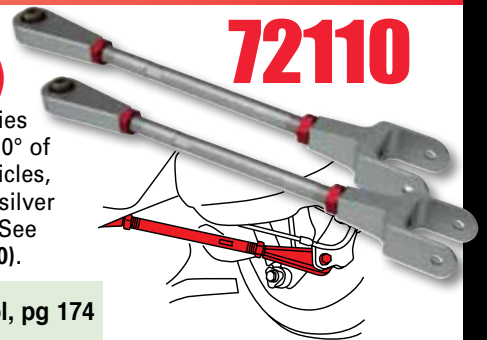

72110

Rear Adjustment range:
Camber -1.00° to $+3.00^{\circ}$

Required:

72115 1 per axle
72116 1 per wheel Right Side
72117 1 per wheel Left Side

APPLICATIONS

BMW: 2007 & Up X5
2008 & Up X6

For OE Replacement Arms without any camber change see #12116 and #12117, page 151.

BMW REAR CAMBER KIT

BMW's X5 is notorious for running negative camber and wearing tires. Use these adjustable rear upper control arms to change camber from -1 to $+3$ degrees. Featuring bonded rubber bushings and booted adjustable ball joints, this pair of forged aluminum arms will let you set camber to where you want it while maintaining factory ride quality and noise vibration and harshness (NVH.) The 72115 kit is a pair of arms, it will give you change on both sides. Use SPC part #72116 for the right side, or part #72117 for the left.

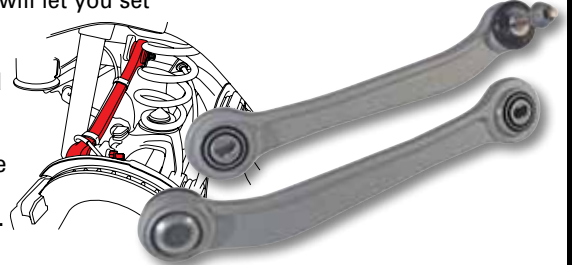

72115

PAIR

72116 72117

RIGHT SIDE LEFT SIDE

Parts

72123

350Z & G35 FRONT UPPER CONTROL ARMS (PR)



This popular adjustable upper control arm/shim kit has been designed to match the SPC family of Nissan and Infiniti arms. Our tubular design has reduced weight by 1 pound per arm and increased rigidity. SPC's arms are the only 350Z arms on the market that can get +3.5° to -1.5° camber change. Additionally, you will be able to set your caster at ±1°.

This patented design makes camber and caster adjustment easy using the sliding and rotating ball joint. The kit includes everything needed, including the ABS sensor bracket, shims, Jounce Spacers and the adjustable arms.

Patent No. US 7,513,514

Front Adjustment range:
Camber -1.5° to +3.5°
Caster ±1.0°



Required: 1 per axle

APPLICATIONS

Infiniti: 2003 - 07 G35 Coupe
(with and w/o active steer)
2003 - 06 G35 Sedan

Nissan: 2003 - 08 350Z



8370 - Puller,
pg 163

These arms feature our Jounce Spacers for a quieter, OE style ride

See page 114 for our premium design for these applications

72130

370Z & G37 FRONT UPPER CONTROL ARMS (PR)



This pair of front upper control arms will give you ±1° caster and ±2.5° camber change. Simply replace the OE front upper control arms and dial in your suspension angles with our patented sliding ball joint and caster plate. Whether you want to tune your suspension for the ultimate in handling performance, minimize tire wear or easily move back and forth between two settings, these are the arms to get the job done.

Patent No. US 7,513,514

These arms feature our Jounce Spacers for a quieter, OE style ride

Front Adjustment range:
Camber ±2.5° Caster ±1.0°



Required: 1 per axle

APPLICATIONS

Infiniti: 2008 - 12 EX35
2011 - 12 G25 Sedan
2007 - 08 G35/G35X Sedan
2009 - 13 G37/G37X Conv., Sedan
2008 - 13 G37 Coupe
2006 - 10 M35/M45
2015 Q40
2014 & Up Q50, Q60
2014 - 17 QX50

Nissan:
2009 & Up 370Z

72180 72190

BMW FRONT ADJ. UPPER STRUT MOUNTS (PR)

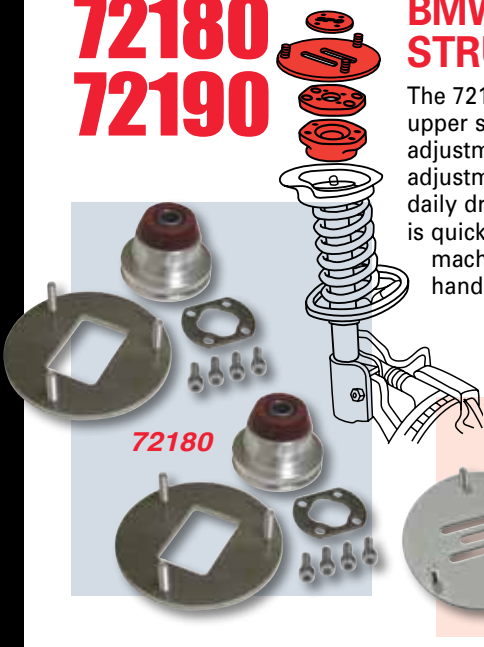

The 72180 and 72190 BMW fully adjustable upper strut mount pair allows full camber adjustments from -1° to +3° and caster adjustments from ±.5°. Full adjustment for daily drivers to high performance racing angles is quickly and easily accomplished. Precision machining and components equals precision handling.



72095 - pg 169 - Use this tool for struts with adjustable damping

Front Adjustment range:
Camber -1.00° to +3.00°
Caster ±.50°



Required 1 per axle

72180 APPLICATIONS

BMW RWD: 1996 - 04 5 Series
528i w/EDC, 540i, 540iT, M5 (E39)

72190 APPLICATIONS

BMW RWD: 2008 - 13 1 Series (E81, E82, E87, E88)
2007 - 13 3 Series Coupe/Conv. (E92, E93)
2006 - 12 3 Series Sedan/Wagon (E90, E91)

See page 107 for additional adjustable front strut mounts for AWD 1 & 3 Series and more

Applications

Alignment Parts

Heavy Duty

OE Replacement

Racing/Builders

Tools

Brake and CV

Gear/Index

Rear Adjustment range:
Camber $\pm 1.25^\circ$ Toe $\pm 1.25^\circ$
Required: 1 per wheel

APPLICATIONS

BMW RWD:

- 1996 - 04 5 Series
528 w/EDC, 540i, 540iT, M5 (E39)
- 1996 - 03 5 Series
525i, 528 w/o EDC, 528iT, 530i (E39)
- 2004 - 10 6 Series
Incl. M6 (E63)



BMW 5/6 SERIES ADJ. REAR BUSHINGS (PR)

These rear control arm bushings provide an additional $\pm 1.25^\circ$ of camber and toe adjustment for the rear of the BMW 5 series. Replace the inboard bushings on the rear upper control arms with these innovative adjustable bushings for lifetime adjustability. Use standard bushing press sleeves and bushing press tool **72509** to remove the old bushings and press in the new ones.



72509 - Ball Joint Press, pg 169

Applications
Alignment Parts

Rear Adjustment Range:
72240 (3 ARM SET)
Camber: $\pm 3.0^\circ$ /Toe: $\pm 3.0^\circ$ /
Setback: $\pm 1.0^\circ$

- 72245** Camber: $\pm 3.0^\circ$
- 72250*** Setback: $\pm 1.0^\circ$
- 72255*** Toe: $\pm 3.0^\circ$

*** 72250 and 72255 MUST be used with arm 72245**

Required: 1 per wheel

APPLICATIONS

- Infiniti:** 2014 - Up Q50, Q60, Q70
2011 - 2013 M35h, M37, M56

See the web for in-depth information on this kit and how it will work in the Infiniti multi-link suspension.

INFINITI REAR ADJUSTABLE 3 ARM SET

Use this three arm set (3) to make the rear of your Infiniti Q50 or Q70 fully adjustable for camber, toe and wheel setback. Whether you are modifying for stance, want adjustability for the track or simply need to replace an OE arm, this is the kit for you. The camber link provides $\pm 3^\circ$ camber, the toe link will give $\pm 3^\circ$ beyond the OE cam and the adjustable trailing link makes $\pm 1"$ setback adjustment possible so you can maintain factory wheel base or get the tire exactly where you want it in the wheel well. These links all feature high durometer bonded rubber bushings to maintain factory ride quality and all steel construction for strength when you need it.

Attention: the sequence of arm adjustments made is extremely important when upgrading to this multi-link system.

72240
Camber **72245**
Lateral **72250**
Toe **72255**

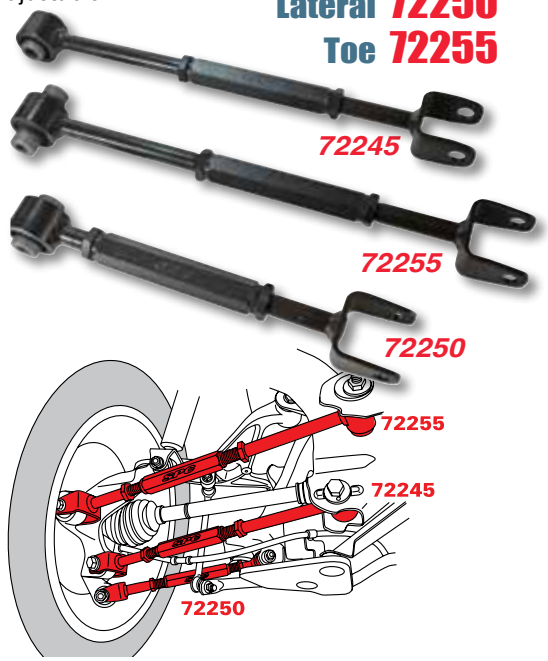

72245 - REAR CAMBER ARM

Use this adjustable control arm from SPC Performance to make the rear of your Infiniti Q50 or Q70 fully adjustable for camber. The remove and replace link will provide $\pm 3^\circ$ of camber and is part of the 72240 set. Attention: toe and set-back will change as you adjust camber with this arm, you may run out of toe change on the factory cam and desire to correct for set-back. Consider toe link p/n 72255, adjustable trailing link p/n 72250 or the three arm set p/n 72240.

See page 114 for our patented front upper control arms for this platform.

72250 - REAR LATERAL ARM

Use this adjustable trailing link from SPC Performance to make the rear of your Infiniti Q50 or Q70 fully adjustable for set-back / wheel base. The remove and replace link will provide $\pm 1"$ movement to adjust for other suspension modifications and is part of the 72240 set.

72255 - REAR TOE ARM

Use this adjustable control arm from SPC Performance to give the rear of your Infiniti Q50 or Q70 extended toe adjustability. The remove and replace link will provide an additional $\pm 3^\circ$ of toe beyond what the OE cam bolt offers and is part of the 72240 set. This will often be necessary to adjust for camber adjustments made with an adjustable upper link like p/n 77245.



Heavy Duty

OE Replacement

Racing/Builders

Tools

Brake and CV

Gear/Index

Parts

72260

NISSAN/INFINITI EXTREME REAR CAMBER/TOE KIT

This is the perfect kit for lowered Zs or G35 and G37 Infinitis. Provides additional camber and comes with a larger offset toe cam to bring the toe angle back into range. Use the **85130** rotary file to elongate the toe slots.

Rear Adjustment range:
Camber $\pm 3.00^\circ$ Toe $\pm 2.00^\circ$

Required: 1 per wheel

APPLICATIONS

Infiniti: 2011 - 12 G25
2006 - 07 G35 Coupe w/rear active steer
2007 - 08 G35/35x Sedan Incl. active steer
2008 - 13 G37 Coupe; 2009 - 13 G37 Sedan
2006 - 10 M35/45; 2015 Q40

Nissan: 2009 & Up 370 Z



85130 - Rotary File Set, pg 173



Applications

Alignment Parts

Heavy Duty

OE Replacement

Racing/Builders

Is

Brake and CV

Gear/Index



See page 106 and 111 for additional rear arms for Nissans and Infinitis

72262

NISSAN/INFINITI PERF. REAR CAMBER/TOE KIT AND LOCKING PLATES (PR)

Dial in $\pm 3.0^\circ$ camber and $\pm 2.0^\circ$ of toe to maximize your suspension set-up on the 370Z and G35/37 with this set of race ready adjustable rear lower control arms, camber lockout plates, and extended range toe cams from SPC. Specifically designed for track use, these arms include SPC's xAxis™ sealed flex joints that perform like monoballs, but with non-metal bushings which will last longer than OE bushings. These arms combine xAxis with forged steel receivers and straight-arm construction to minimize compliance under load. The lockout plates replace the OE camber cams giving you extra assurance that your camber is locked in.

Rear Adjustment range:
Camber $\pm 3.00^\circ$ Toe $\pm 2.00^\circ$

Required: 1 per axle

APPLICATIONS

Infiniti: 2011 - 12 G25
2006 - 07 G35 Coupe
w/rear active steer
2007 - 08 G35/35x
Sedan Incl. active steer
2008 - 13 G37 Coupe
2009 - 13 G37 Sedan
2006 - 10 M35/45
2015 Q40

Nissan: 2009 & Up 370 Z



85130 - Rotary File Set, pg 173

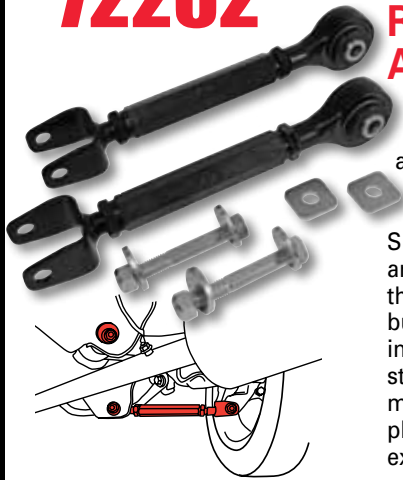

72265

NISSAN/INFINITI REAR CAMBER/ TOE KIT (PR)

These cams (set of 2) replace the OE camber and toe adjustment cams and provide additional camber and toe changes. Adjustment slots will need to be elongated using **85130** rotary file or equivalent.

Rear Adjustment range:
Camber $\pm 2.00^\circ$ Toe $\pm 2.00^\circ$

Required: 1 per wheel

APPLICATIONS

Infiniti: 2009 - 13 FX35; 2003 - 08 FX45
2011 - 12 G25
2006 - 07 G35 Coupe w/rear active steer
2007 - 08 G35/35x Sedan Incl. active steer
2008 - 13 G37 Coupe incl. active steer
2009 - 13 G37 Sedan; 2006 - 10 M35/45
2015 - 15 Q40, 2014 & Up Q60
2014 - 15 Q60 Coupe; 2014 - 17 QX50/70

Nissan: 2009 & Up 370 Z

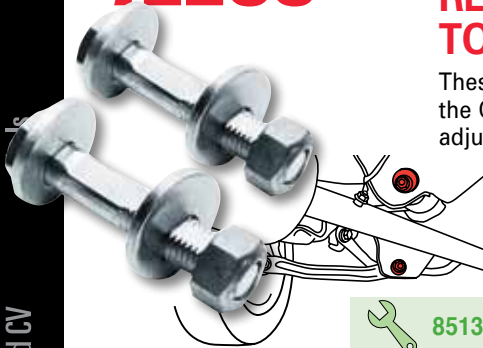

85130 - Rotary File Set, pg 173

72270

LEXUS GS ADJUSTABLE FRONT ARMS (PR)

This pair of Lexus upper control arms will give you $\pm 1^\circ$ caster and $\pm 2.0^\circ$ camber change. Simply replace the OE front upper control arms and dial in your suspension angles with our patented sliding ball joint and caster plate. Whether you want to tune your suspension for the ultimate in handling performance, minimize tire wear or easily move back and forth between two settings, these are the arms to get the job done.

Front Adjustment range:
Camber $\pm 2.0^\circ$ Caster $\pm 1.0^\circ$

Installation Time: .6 hr/side

Required: 1 per axle

APPLICATIONS

Lexus: 1993 - 05 GS
2002 - 10 SC



Patent No. US 7,513,514 B



Rear Adjustment range:
Camber $\pm 3.0^\circ$ Toe $\pm 2.0^\circ$

Required: 1 per wheel

APPLICATIONS

Nissan: 2007 - 13 Altima Coupe
2007 - 12 Altima Sedan

NISSAN ALTIMA ADJ.REAR CONTROL ARM

72290

These arms fit the popular Nissan Altima. Simply replace the OE fixed length lower rear control arm with this adjustable arm to achieve $\pm 3^\circ$ of camber change. Use the included toe cam bolt to get up to $\pm 2^\circ$ of toe change. The arm and cam kit can be used for vehicles with stock ride height or lowered for performance.

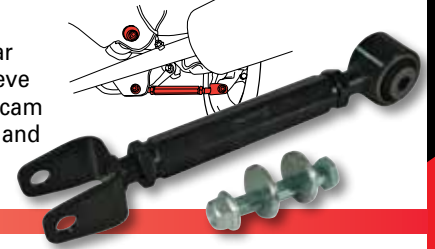

Rear Adjustment range:
Camber $\pm 2.5^\circ$

Required: 1 per wheel

APPLICATIONS

Nissan: 2013 Altima Sedan
2014 & Up Altima
2016 & Up Maxima

NISSAN ALTIMA ADJ. REAR CAMBER ARM

72295

Replace the non-adjustable rear upper control arm on the Nissan Altima with SPC's fully adjustable arm to get $\pm 2.5^\circ$ of camber change. This remove and replace arm is perfect for traditional alignment correction, to enhance handling, or as a direct replacement chassis part.



Rear Adjustment range:
Pinion $\pm 4.0^\circ$ Add'l Thrust

Required: 1 per axle

APPLICATIONS

Ford: 2005 - 14 Mustang

MUSTANG REAR ADJUSTABLE TRAILING ARMS (PR)

72345

These adjustable rear trailing arms for 2005 - 14 Ford Mustang offer you the ability to adjust thrust, tracking, and pinion angle to optimal specs for your driving style or track conditions. Made of 6061 aluminum, these light weight, high strength arms look great with a black e-coat finish.



Check out SPC's adjustable panhard bar #72045 (pg 106) and adjustable front strut mounts #72040 (pg. 105)

Front Adjustment range:
72350 Camber $\pm 1.5^\circ$
Caster $\pm .5^\circ$

Required: 1 per axle

72355 Caster $\pm .5^\circ$

Required: 1 per axle

APPLICATIONS

Ford: 2005 - 14 Mustang

US Patent Nos. 8,544,861 • 8,469,375 • D783,393
China Patent No. 201630012294.X

 **85130 - Rotary File Set, pg 173**

MUSTANG FRONT ALIGNMENT KITS

72350 72355

72350 Kit bundles a pair of EZ Cams (p/n 81260) for adjusting camber $\pm 1.5^\circ$, with two **72355** Caster Bolts (below). Together these parts overcome the non-adjustable factory design to provide complete adjustability for improved handling, reduced tire wear, and better drivability.

72355 Cam bolt kit provides caster adjustment by replacing one of the two factory bolts that mount the rear control arm bushing bracket. Elongation of the pre-marked factory holes is required - we recommend using rotary file set 85130 or similar. Includes one smaller cam.



#72355 Includes only One Caster Cam



SPC Knows Mustangs

From the classic '64.5 to the current S550, SPC is on the leading edge of alignment parts for these popular vehicles. Whether you are looking to race on weekend, or bring back the tracking and handling in your classic ride, check out our apps for the parts you need.

Parts Mustang S550

72360 MUSTANG REAR PERFORMANCE KIT (4)



Get the optimum track set-up with SPC's 4-arm set. This set includes 2 each of the 72370 and 72380 (below). With aggressive handling and maximum G's, track vehicles require the best adjustment, reduced weight vs the OE arm and extra strength. These aluminum forged arms give you a complete solution for your track-ready S550.

Rear Adjustment range:
72360 Camber -2.00° to $+3.00^{\circ}$
Toe $\pm 3.0^{\circ}$

Required: 1 per axle

72370 Camber -2.00° to $+3.00^{\circ}$

Required: 1 per wheel

72380 Toe $\pm 3.0^{\circ}$

Required: 1 per wheel

APPLICATIONS

Ford: 2015 & Up Mustang

72370

MUSTANG REAR CAMBER ARM

Add a little horsepower, use grippy tires, launch hard, and take a corner at 1.5 G's. You need an adjustable rear control arm to optimize your tire contact by adjusting your camber. Be confident your arm is proven and reliable for the >1,000 pounds of force that it will be loaded with over and over again as you put your Mustang to the test. Designed, engineered, tested, and assembled in Colorado. SPC's forged T6 aluminum link will provide; -2 to +3 degrees of camber adjustment, reduced weight vs the OE arm and exceed its strength. SPC's adjustable arm features high rate rubber bushings to maintain OE noise, vibration, and harshness (NVH) and has a 1.5" hexed eccentric insert at the knuckle end of the arm to easily adjust camber without removing the tire. All hardware is included and features hex chromate free finish (certified to 700 hour salt spray test standards) for rust free long life.

US Patent No.
10,450,005

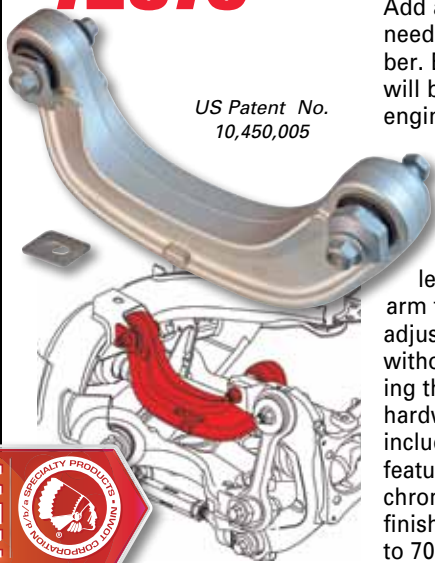

High Rate Rubber Bushings

- Maintains OE NVH (Noise, Vibration and Harshness) levels
- Longer life vs rod ends
- Provides performance handling

2 Lock Plates for OE Slot

- No slippage

All hardware included

- Bolts, nuts, plates, cams, inserts, washer for both ends of arm
- Hex chromate free, environment friendly, 700 hr salt spray tested for rust-free long life

Fully Forged Aluminum Arm

- 11% weight saving vs. OE arm
- Maintains factory frame and drive shaft clearance
- Exceeds OE strength

-2° to +3° Camber Change

- Improve rear tracking and handling
- Fine-tune change with eccentric insert
- Easy 'live' adjustment with the wheel on

74400 - Wrench,
pg 170

72380

MUSTANG REAR TOE ARM

Upgrade your rear suspension for added toe adjustment and less weight with this aluminum control arm from SPC. This lower arm features a xAxis sealed flex joint that performs like a monoball, but uses non-metal bushings which are designed to last like an OE bushing. Fully forged with T6 aluminum, this high strength arm will inspire confidence on the track while withstanding the rigors of street driving. Included lockout cam will replace the factory toe cam to make sure your alignment settings aren't changing during cornering.

12050 - Check out our weight-saving toe arm on page 150



72450

LEXUS REAR CAMBER LINK

Use this adjustable rear upper control arm to replace the OE arm and get $\pm 3^{\circ}$ of camber. SPC's adjustable camber link is manufactured from high-grade aluminum, is easy to adjust on car, includes a mounting bracket for the ABS wire, and has OE style bushings to maintain factory ride quality. Whether you want a cambered look, are heading to the track, or want to save the tread life on your tires, these arms are for you.

Rear Adjustment range:
Camber $\pm 3.00^{\circ}$

Required: 1 per wheel

APPLICATIONS

Lexus:

2014 & Up IS
Except Convertible
2013 & Up GS
2015 & Up RC



Applications

Alignment Parts

Heavy Duty

OE Replacement

Wrenches

Tools

Brake and CV

Gear/Index

Porsche 996/997 • 981/986/987

72610

Front/Rear

Adjustment range:

Camber $\pm 2.00^\circ$

Required: 1 per axle

NOTE: MODELS EQUIPPED WITH HYDRAULIC BUSHINGS MUST BE PRESSED OUT AND REUSED FROM THE ORIGINAL CONTROL ARMS

72630

Front Adjustment range:

Camber $\pm 1.25^\circ$

Rear Adjustment range:

Setback $\pm 0.5"$

Required: 1 per wheel

72640

Rear Adjustment range:

Toe $\pm 3.0^\circ$

Required: 1 per wheel

APPLICATIONS

(See website for details)

Porsche: 1999 - 11 911 (996/997)
1997 - 16 Boxster (987/981/986)
2006 - 12 Cayman (987)



72613 Rebuild Kit for 72610

Includes: Ball stud, ball stud nut, race, boot, and press tool.



72120 - Spanner Wrench, pg 169

PORSCHE REAR PERFORMANCE KIT (6)

72600

Get the optimum track set-up with SPC's 6-arm set. This set includes 2 each of the 72610, 72630 and 72640 (below). With aggressive handling and maximum G's, track vehicles require the best adjustment and extra strength vs the OE arm. These aluminum forged arms give you a complete solution for your track-ready 996/997 or 981/986/987.



NEW

Align

Heavy Duty

OE Replacement

Racing/Builders

Tools

Brake and CV

NEW

Gear/Inte

NEW

PORSCHE FRONT OR REAR ADJUSTABLE ARMS (PR)

72610

Make the non-adjustable lower control arms on your 996 or 997 Porsche adjustable for up to $\pm 2^\circ$ camber adjustment. This pair of forged 6061-T6 aluminum arms (2) from SPC will give easy on-the-car adjustability as well as get you track ready, while maintaining OE Noise Vibration and Harshness (NVH) levels with booted ball joints and high durometer bonded rubber bushings. SPC offers the only greasable and rebuildable ball joint on the market. If you wear out your ball joint race with heavy track use, (it happens) you can get a rebuild kit (#72613) and avoid the cost of a whole new arm. This set can be used for front or rear, so if you want adjustability on all four corners you will need two sets. **Sold as pairs.**



Features

- Rebuildable ball joint is booted and greasable
- Forged 6061-T6 Aluminum construction for maximized strength at a minimum weight
- OE sized and style bushings can be replaced with any aftermarket or OE bushing option
- Adjusting bolt offers precise camber adjustment
- Provision for the ride height sensor of litronic headlight equipped cars

Benefits

- $\pm 2^\circ$ camber adjustment
- Rebuildable ball joint
- Fast, easy, on-car adjustment

PORSCHE TRAILING LINK (PR)

72630

Upgrade the front or rear non-adjustable factory trailing arms on your Porsche 996 and 986 with this pair of fully adjustable arms from SPC Performance. Constructed from forged 6061-T6 aluminum with a hard black anodized finish, they adjust with an easy to reach threaded adjuster and maintain factory ride with SPC's xAxis™ sealed flex joints which eliminate binding and bushing compliance. Installed on the front, you will be able to adjust caster $\pm 1.25^\circ$. SPC has maintained the OE form so that you will be able to reuse your factory air deflector without modification. Installed on the rear you will be able to adjust set-back $\pm 1/2$ inch (± 13 mm). Designed for street use as well as the rigors of the track, these arms will let you set your alignment angles where you want them for the way you drive. **Sold as pairs.**

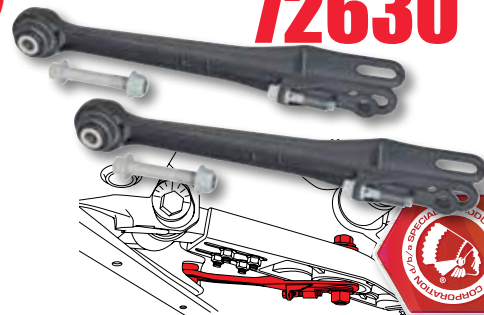

NEW

PORSCHE REAR TOE LINK (PR)

72640

Adjust toe $\pm 3^\circ$ with this pair of adjustable toe links. SPC's forged aluminum construction avoids any weight penalty while maintaining factory strength. The integrated ball joint means smooth bind free articulation and no maintenance required. **Sold as pairs.**

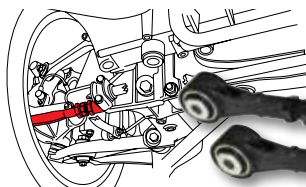

NEW

Parts

72645

PORSCHE REAR TOE CAM

Replace corroded or damaged OE toe cam bolts on the rear of many late model Porsche vehicles with this replacement cam kit from SPC. This cam kit is designed to replace the factory adjusters and provide the same amount of adjustment as the factory part it is replacing. The hex chromate free finish offers a 700hr salt spray test for the best corrosion protection available. One kit is used for each side of the vehicle.

Rear Adjustment range:

Factory Toe - $\pm 1.0^\circ$

Required: 1 per wheel

APPLICATIONS

(See website for details)

Porsche: 1999 - 11 911 (996/997)
1997 - 19 Boxster (987/981/986)
2006 - 19 Cayman (987/981)

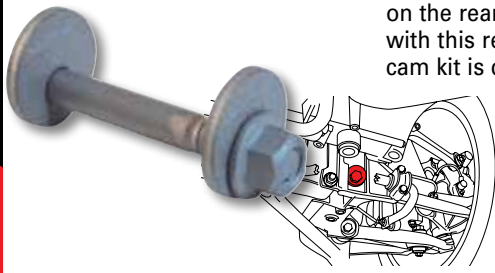

73000

G35/350Z AND G37/370Z ADJ. CONTROL ARMS (PR)

This pair of patented adjustable front upper control arms will give up to $\pm 4^\circ$ camber and $\pm 4^\circ$ caster change on the 73000 and $\pm 3^\circ$ camber and $\pm 3^\circ$ caster change on the 73005. The rubber isolated xAxis™ sealed flex joints retain OE bushing values (Noise, Vibration, and Harshness - NVH), while providing the handling qualities of a mono-ball. Optimized geometry and high strength forged steel components make this the strongest adjustable arm on the market today. Whether you want a cambered stance, improved handling, or to minimize tire wear, these are the best arms for you.

Features

- Most camber and caster adjustability on the market
- Best clearance of any adjustable control arm
- Turnbuckle adjusters for easy on car alignment
- High strength forged steel components
- Optimized geometry reduces stresses to pure tension and compression for maximized strength and minimized weight
- xAxis™ Sealed Flex Joints with rubber isolation at the inner bushing
- Sealed ball joint with high polished ball for extended wear

Benefits

- Up to $+4^\circ$ of camber change without inner fender well contact
- Easy to adjust
- Sealed joints means no corrosion or contamination in the joints
- Set your camber and caster where you want it for
 - **Look** "Cambered" appearance
 - **Driving style** Improved handling and cornering
 - **Tire wear** Adjust angles to minimize tire wear
- Retain factory Noise, Vibration, Harshness (NVH) values but gain handling quality of a mono-ball with xAxis™ sealed flex joint isolated by an OE style bonded rubber bushing

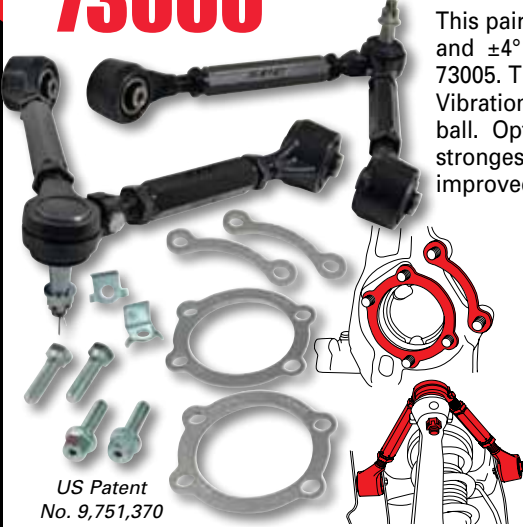

US Patent No. 9,751,370

The 73000 SPC arms match the OE -design for clearance so you can get up to $+2^\circ$ camber change without fender well interference. If more positive change is needed use the included $+2^\circ$ camber shims for fixed change and dial in the rest with your arms.

73005



US Patent No. 9,751,370

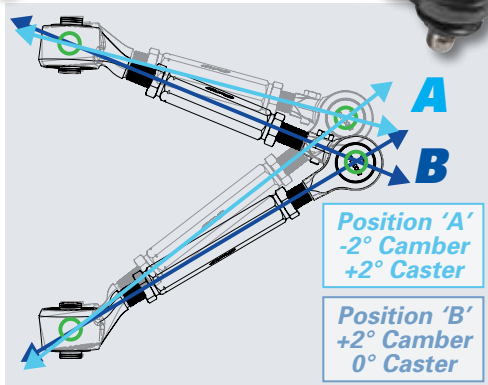

73000 Front Adjustment range (Includes shim pack):
Camber $\pm 4.00^\circ$ Caster $\pm 4.00^\circ$

Required: 1 per axle

APPLICATIONS

Infiniti: 2003 - 07 G35 Coupe (with & w/o active steer)
2003 - 06 G35 Sedan

Nissan: 2003 - 08 350Z

8370 - Puller, pg 163

73005 Front Adjustment range:
Camber $\pm 3.00^\circ$ Caster $\pm 3.00^\circ$

Required: 1 per axle

APPLICATIONS

Infiniti: 2008 - 12 EX35; 2009 - 13 FX35; 2011 - 12 G25 Sedan
2007 - 08 G35/G35X Sedan; 2008 - 13 G37 Coupe;
2009 - 13 G37/G37X Conv., Sedan
2006 - 10 M35/M45; 2015 Q40; 2014 & Up Q50;
2014 - 17 QX 50; 2014 & Up Q60

Nissan: 2009 & Up 370Z



Featured at the 2019 SEMA Show

Jeremy Lopeman's 2015 RTR Mustang was the star of the SPC booth. This heavily modified S550 featured a laundry list of upgrades including: Vortech Superchargers; AUS Injectors; BMR Racing Tuning; BC Forged Multipiece Wheels; RTR body modifications, axleback mufflers and coilover suspension, grilles w/lights, and Nitto Tires. And to get all those mods to stick during heavy cornering, SPC 72370 Rear Camber Arms (page 112) - of course!



Rear Adjustment range:
Camber +.25° to +.75°

Required: 1 per axle

APPLICATIONS

- Chrysler:** 1995 - 00 Sebring
2001 - 06 Sebring 2Dr Coupe
- Dodge:** 1995 - 00 Avenger
2001 - 05 Stratus
- Eagle:** 1995 - 98 Talon
- Mitsubishi:** 1997 - 04 Diamante
1995 - 05 Eclipse, 1994 - 03 Galant

CHRYSLER/MITSUBISHI REAR SHIM PACK

For positive camber change use our **73400** rear shims (6 per pack) that allow for quick and easy camber changes in increments of .25° up to .75°. Each shim changes camber by .25°, the entire pack equals .75° change if all shims are used.

73415

BOLT SET - Set of 4 bolts.

NOTE: Changes in camber greater than .75° require an additional shim kit and the installation of longer bolts. Use these bolts - Specialty Part 73415.

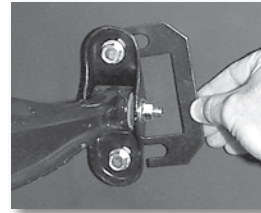

73400 SHIM PACK

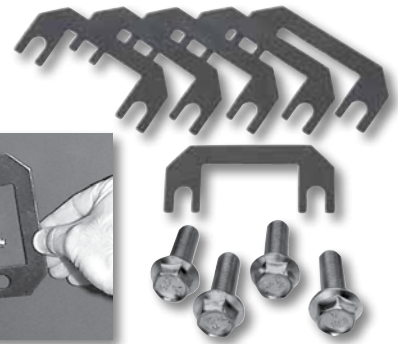

Rear Adjustment range:

73600 Camber -.75° to +1.50°

73620 Camber -.75° to +3.00°

Required: 1 per wheel

APPLICATIONS

- Chrysler:** 1995 - 00 Sebring
2001 - 06 Sebring 2Dr Coupe
- Dodge:** 1995 - 00 Avenger
2001 - 05 Stratus
- Eagle:** 1995 - 98 Talon
- Mitsubishi:** 1997 - 04 Diamante
1995 - 05 Eclipse, 1994 - 03 Galant



CHRYSLER/MITSUBISHI REAR CAMBER BOLT AND BRACKET (PR)

This bolt and bracket set allows for greater rear camber change on 1995 and up Sebrings, Avengers, Talons and Eclipses. One kit covers one side of the vehicle.

PART NO. 73600

(No Spacers)

PART NO. 73620

(With Spacers & Bolts)

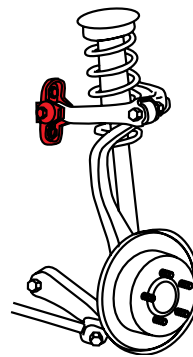

73600 73620



Parts

- 75200** BLUE
- 75400** GREY
- 75600** YELLOW
- 75800** RED

EZ Shim™ FULL CONTACT DUAL ANGLE

A Full Contact Dual Angle shim, consisting of only four part numbers, that corrects Toe and Camber with one shim.

These two-piece adjustable shims are available in 4 sizes which cover many rear shimable FWD vehicles. Durable construction, proven adjustment changes within .03° toe and .10° camber.

CAUTION: Check for caliper to rotor clearance when installing this part on vehicles equipped with rear disc brakes. Some vehicles may require the use of longer bolts.

Recommend use of 10408 bolts (page 73) and 75970 spacers (below) as required

Applications

Alignment Parts

Heavy Duty

OE Replacements

Racing/Builders

Tools

Brake and CV

Gear/Index



 **75915 - EZ Shim Cutter (below)**

ACCESSORIES

75910 DIAL CHART

75910
EZ Shim™ dial Chart lists changes in decimal degrees only.

Makes using the EZ Shim a snap. Just dial in the desired change needed for both camber and toe.

75915 CUTTER



This cutter is a necessary tool for cutting the EZ Shim™ Its thin cutting blades minimize shim breakage.

75920 MARKER



This will mark the areas to be removed. Marks will not rub off, and are easy to see.

75970 SPACER SET (8)



This set (4 different sizes - 2 of each) aligns caliper to rotor after installation of a camber shim. Specifically designed to be used with the EZ Shim when correcting some FWD cars with hub mounted rear disc brakes.

Rear Adjustment range:
Camber ±1.50°/Toe ±1.50°

Required: 1 shim per wheel

APPLICATIONS

See application charts, pages 7-70 for vehicle models and years.

75200 (Blue)

Audi, Chevrolet, Chrysler, Dodge, Eagle, Ford, Geo, Isuzu, Nissan, Pontiac, Plymouth, VW

75400 (Grey)

Audi, Buick, Cadillac, Chevrolet, Chrysler, Dodge, Ford, Mercury, Nissan, Olds, Plymouth, Pontiac, Saturn

75600 (Yellow)

Buick, Cadillac, Chevrolet, Chrysler, Dodge, Geo, Honda, Hyundai, Kia, Nissan, Olds, Pontiac, Scion, Toyota, VW

75800 (Red)

Buick, Cadillac, Chevrolet, Geo, Honda, Hyundai, Kia, Nissan, Olds, Pontiac, VW

Available on a handy board set #88700 - page 71



From Shims to Adjustable Arms

The days of merely shimming a vehicle has given way to complex solutions such as adjustable arms and multilink sets. For over 45 years Specialty Products has been the innovator in modern alignment and continues to lead the industry with the newest in alignment solutions.

Rear Adjustment range:
Camber ±1.50° Toe ±1.50°

Required: 1 per wheel

APPLICATIONS FWD ONLY

- Nissan:** 2009 - 14 Cube
2013 & Up Sentra
2007 - 2011 Versa
- Pontiac:** 2003 - 10 Vibe
- Toyota:** 2003 - 08 Corolla
2003 - 13 Matrix

 **75915 - Cutter, above**

75610

REAR SHIM AND BOLT KIT

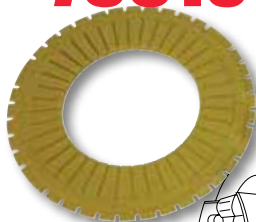

Adjust rear camber and toe up to ±1.5° on many popular front wheel drive vehicles with this universal shim kit. The kit includes extended length hub bolts so that you will have everything you need to do the job right.

Improve tire wear, gas mileage and handling by getting alignment into specification.

NOTE: Vehicles with rear disc brakes may also need caliper spacer kit #75970 (above).

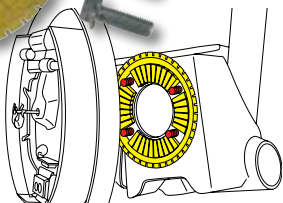

81240, 81250, 81260, 81270, 81280, 81290, 81295 EZ Cam™ XR

FOR DOMESTIC/IMPORT TWO BOLT STRUTS

Front Adjustment range:
Camber $\pm 1.75^\circ$

Required: 1 per axle

APPLICATIONS

See application charts,
pages 7-70 for years.

81240 pr (10mm)

Fiat

81250 pr (12mm)

Buick, Chevrolet, Cadillac, Daewoo,
Dodge, Eagle, Fiat, Ford, Geo, GMC,
Hyundai, Isuzu, Kia, Mazda, Mercury,
Mitsubishi, Nissan, Olds, Plymouth,
Pontiac, Porsche, Saab, Saturn,
Suzuki, Toyota, Volkswagen, Volvo

81260 pr (14mm)

Acura, Buick, Chevrolet, Chrysler,
Dodge, Ford, Honda, Hyundai, Infiniti,
Jeep, Kia, Mazda, Mercedes Benz,
Mitsubishi, Nissan, Olds, Pontiac,
Plymouth, Saturn, Scion, Subaru,
Toyota, Volvo

81270 pr (15mm)

Lexus, Scion, Subaru, Toyota

81280 pr (16mm)

Acura, Buick, Cadillac, Chevrolet,
Chrysler, Dodge, Eagle, Ford, Honda,
Hyundai, Kia, Lincoln, Mazda, Mercury,
Mitsubishi, Oldsmobile, Pontiac,
Saturn, Toyota

81290 pr (17mm)

Lexus, Pontiac, Scion,
Toyota

81295 pr (18mm)

Acura, Honda

EZ Cams™ make non-adjustable two bolt struts adjustable up to $\pm 1.75^\circ$ camber change. Head markings show where the cam is for maximum change and an easy-to-manipulate toothed washer lets you set positive or negative change. Simply remove the upper OE bolt, loosen the lower bolt, install and adjust the EZ Cam to the desired change and then tighten everything to specification. This is an easy fix for camber issues and a perfect companion sale for any strut job. Save time, money and effort by making aligning two bolt struts a one man job without grinding. Keep one of each part number in stock, measure the OE threads, replace the OE bolt with SPC's EZ Cams to make your alignment jobs fast and profitable.

Part No. 81240 (pr)
For replacement of 10mm bolts

Part No. 81250 (pr)
For replacement of 12mm bolts

Part No. 81260 (pr)
For replacement of 14mm bolts

Part No. 81270 (pr)
For replacement of 15mm bolts

Part No. 81280 (pr)
For replacement of 16mm bolts

This kit may also be used on GM vehicles equipped with aftermarket slotted struts with the addition of our adapter plate, 81286 included with cams.

Part No. 81290 (pr)
For replacement of 17mm bolts

Part No. 81295 (pr)
For replacement of 18mm bolts

US Patent Nos.
8,544,861 • 8,469,375 • 10,450,005
D783,393
China Patent No.
201630012294.X

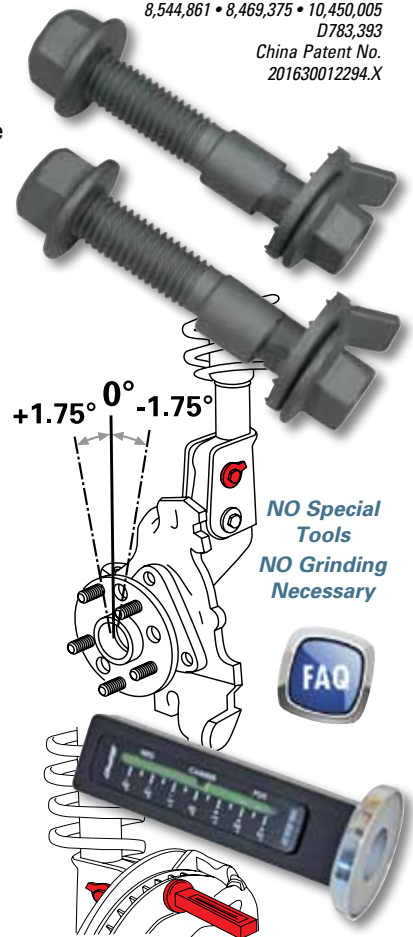

Check camber change before,
during and after installation
with our 81139 Magnetic
Camber Gauge (page 172)

**Got Aftermarket Struts
with a Slotted Hole?
We have the answer!**

Our 83170 (page 125)
fits many aftermarket
slotted struts.

It is easy to find out if
the 83170 camber kit
will fit your aftermar-
ket strut with only
two measurements:

A = The Cam Diameter The 83170 has a
1.3" Diameter Cam

B = The Bolt Size The 83170 has an M14 Bolt

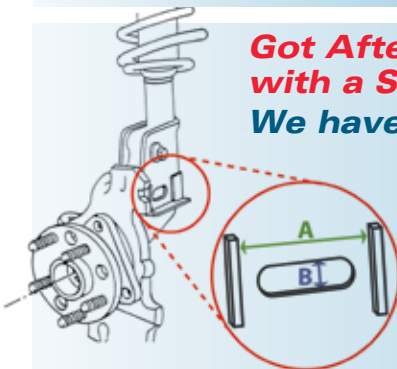

Salt Spray Testing

Competitor's Cam

SPC's EZ Cam™



**SPC's Hex Chromate-Free Finish Leads
the Industry**



**EZ Cam EZ Sizer Magnet
#20503 (pg 182)**

*This magnet sticks on the installer's
tool box, out of the way, and is a
quick reference tool for measuring
the right EZ Cam™ for the job!*

Parts

80199-81099

Truck Axle Shims

ZINC CASTER/PINION SHIMS

These heavy-duty axle caster shims can also be used to adjust pinion angle on Jeep CJs and similar vehicles with 1-3/4" to 2" wide leaf springs. **Note: Shims should not be stacked. Six shims per box**

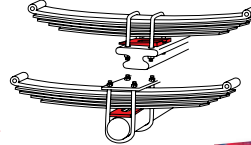

Do you specialize in heavy duty trucks or maintain a truck fleet? Check out our

complete Heavy Duty Truck Section on pages 141-149.

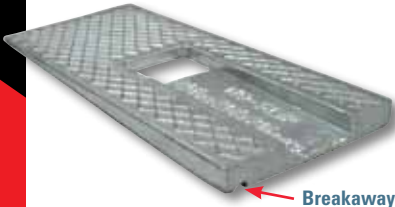

Breakaway

For additional shim widths see page 134

No.	Width	Degree Taper	Qty	No.	Width	Degree Taper	Qty
80199	1-3/4 to 2"	1/2°	6	80699	1-3/4 to 2"	3°	6
80299	1-3/4 to 2"	1°	6	80799	1-3/4 to 2"	3-1/2°	6
80399	1-3/4 to 2"	1-1/2°	6	80899	1-3/4 to 2"	4°	6
80499	1-3/4 to 2"	2°	6	80999	1-3/4 to 2"	5°	6
80599	1-3/4 to 2"	2-1/2°	6	81099	1-3/4 to 2"	6°	6



Applications

Alignment Parts

Heavy Duty

OE Replacement

Racing/Builders

Tools

Brake and CV

Gear/Index

81305

SCION/SUBARU CAM BOLTS (PR)

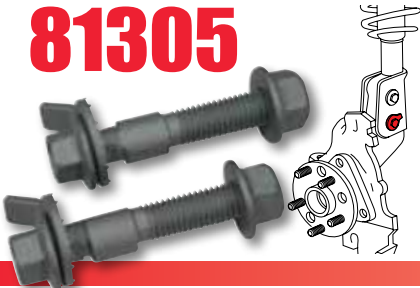

By installing these cam bolts in the **lower bolt position** on the 2 bolt front strut assembly of this popular platform you can dial in front camber adjustments.

US Patent Nos. 8,544,861 • 8,469,375 • D783,393
China Patent No. 201630012294.X

Front Adjustment range:

Camber $\pm 1.75^\circ$

Required: 1 per axle

APPLICATIONS

Scion: 2013 - 16 FR-S

Subaru: All Except Justy

Toyota: 2017 & Up 86

81310

FORD FOCUS REAR CAMBER KIT (PR)

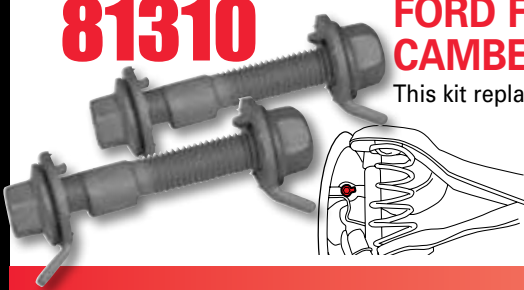

This kit replaces the outer bolt of the upper rear control arm and provides $\pm 1^\circ$ of camber adjustment. Perfect for lowered vehicles or standard alignments.

US Patent Nos. 8,544,861 • 8,469,375 • D783,393
China Patent No. 201630012294.X

Rear Adjustment range:

Camber $\pm 1.0^\circ$

Required: 1 per axle

APPLICATIONS

Ford: 2000 - 11 Focus

Volvo: 2008 - 13 C30

2004 - 12 S40, V50

China Patent No. 201630012294.X



81320

FOCUS/TRANSIT FRONT CAMBER/CASTER KIT



Adjust front camber and caster on Ford Focus and Transit Connect with this adjustable upper strut mount. By replacing the OE strut mount you can get $\pm 1^\circ$ camber and caster.

Front Adjustment range:

Camber $\pm 1.00^\circ$ /Caster $\pm 1.00^\circ$

Required: 1 per wheel

APPLICATIONS

Ford: 2000 - 11 Focus

2010 - 13 Transit Connect



81335

VW REAR CAMBER ARM

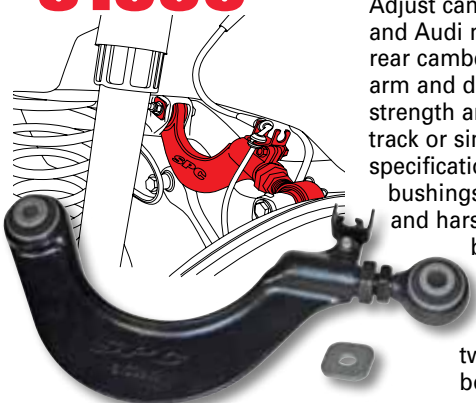

Adjust camber in the rear of many popular VW and Audi models $\pm 3^\circ$ with this fully adjustable rear camber arm from SPC. The forged steel arm and double threaded adjuster offer the strength and on-car adjustment needed for the track or simply getting alignment back to factory specifications. SPC's arm uses bonded rubber bushings to maintain factory noise, vibration, and harshness (NVH) values. Use the included bracket to properly secure the factory ABS wire. The arm is sold per side and can be used for either the right or left hand side. Be sure to order two kits if you need adjustment on both sides.

Rear Adjustment range:

Camber $\pm 3.00^\circ$

Required: 1 per wheel

APPLICATIONS

Audi: 2006 & Up A3/S3

2017 & Up RS3

2008 - 13 TT

Volkswagen:

2011 - 18 Beetle w/multi link susp.

2009 - 16 CC; 2007 - 13 EOS

2010 - 14 Golf; 2008 Golf R32

2006 & Up GTI; 2005 - 17 GLI

2005 & Up Jetta w/multi link susp.

2006 - 10 Passat; 2006 - 09 Rabbit

2009 & Up Tiguan

Front Adjustment range:
Camber $\pm 1.00^\circ$ /Caster $\pm 1.00^\circ$
Required: 1 per wheel

APPLICATIONS

Audi: 2000 - 06 TT FWD/AWD
Volkswagen: 1998 - 10 Beetle
1999 - 06 Golf, GTI (A4)
2004 Golf R32, 1999 - 05 Jetta (A4)

VW/AUDI FRONT CAMBER/CASTER KIT



Adjust both camber and caster with this kit on many models of Volkswagens and Audis. Simply remove the strut assembly, compress the spring and replace the OE upper bearing plate with this adjustable plate assembly.

Front Adjustment range:
Camber $\pm 1.50^\circ$ Caster $\pm 1.50^\circ$
Required:

81353, 81363, 81373, 81383
81358, 81368, 81378, 81388
1 per axle

81352, 81362, 81372, 81382
1 per wheel - right

81351, 81361, 81371, 81381
1 per wheel - left

81351, 81352, 81353
& 81358*

APPLICATIONS

Audi: 1998 - 08 A4/S4/RS4
2007 - 08 A5/S5
1998 - 04 A6/RS6/S6/
Allroad
Volkswagen: 1998 - 05 Passat
w/ beam type rear axle

81361, 81362, 81363
& 81368*

APPLICATIONS

Audi: 2009 - 16 A4/RS4/S4
2012 & Up A6/RS6/S6
Allroad
2009 - 16 A5/S5/RS5
2012 & Up A7/S7/RS7
2009 - 17 Q5
2013 - 17 SQ5

81371, 81372, 81373
& 81378*

APPLICATIONS

Audi: 2005 - 11 A6/S6
2004 - 10 A8/S8
Bentley: 2004 - 12 Continental
Volkswagen: 2004 - 06 Phaeton

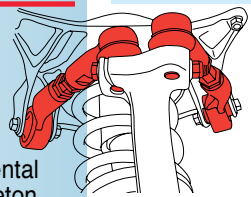

81381, 81382, 81383
& 81388*

APPLICATIONS

Audi: 2017 & up A4/S4
2018 & up A5/S5

**NOTE: 81358, 81368, 81378 and 81388 are performance parts; if OE type noise isolation levels are desired use our 81353, 81363, 81373 or 81383 arm sets.*

AUDI AND VW FRONT UPPER MULTI LINK ARM SET

This set of adjustable upper control arms will allow $\pm 1.5^\circ$ camber and/or caster change on a wide range of Audi and VW models. These arms directly replace factory fixed-length arms, allowing easy adjustments after installation. Engineered for both street and track use, maintenance free ball joints and bushings provide factory ride, handling, and NVH performance.

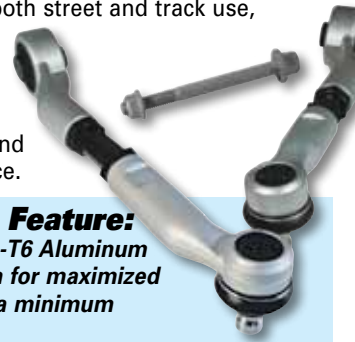

SPC Arms Feature:

- Forged 6061-T6 Aluminum construction for maximized strength at a minimum weight
- Hooked link to maximize clearances
- OE style, maintenance free, booted ball joints
- Large 18mm threaded adjuster links
- Replacement pinch bolts

SPC Performance Arms Add:

- xAxis™ sealed flex joints replacing compliant OE inner bushings with a free pivoting, minimum compliance, joint

AUDI AND VW PERFORMANCE ARMS

Get ready for the track with this four (4) arm set of adjustable upper links for many Audi and VW models. This kit has four arms so you can change camber and caster $\pm 1.5^\circ$ on both sides. xAxis sealed flex joints replace the compliant inner bushings with a free pivoting minimum compliance joint. You will feel the difference in handling.

Warning: You will also hear the difference, the OE bushings are designed to absorb and negate noise, vibration, and harshness (NVH). This set of arms will transmit road noise into the cabin.



SPC's Performance Audi Arms Feature xAxis™

- Sealed joint retains grease and excludes contaminants
- Highly polished electroless-nickel finish on ball maximizes durability
- Up to 45° angularity for high mis-alignment requirements



Parts

81520

AUDI A4 REAR TOE KIT

Restore lost toe adjustment due to frozen or broken adjusters on Audi A4 and S4 models with this replacement toe adjuster cam kit. The kit features a hex chromate free 700 hour salt spray tested finish and is sold per wheel. Order two kits to replace both toe adjusters on a vehicle.



Rear Adjustment range:

Toe $\pm 1.50^\circ$

Required: 1 per wheel

APPLICATIONS

Audi: 2002 - 08 A4/Quattro
2002 - 08 S4/Quattro
2003 - 09 A4 Cabrio/Quattro
2003 - 09 S4 Cabrio/Quattro
2006 - 08 RS4

Applications

Alignment Parts

Heavy Duty

OE Replacement

Racing/Builders

Tools

Brake and CV

Gear/Index



82070

SOLSTICE/SKY CAM BOLTS (PR)

Replace corroded or stripped alignment cam assemblies on the front or rear of the Pontiac Solstice and Saturn Sky with this pair of cam bolts. Use these kits to lock in your alignment adjustment. Pair of cam bolts adjusts camber and caster on the front and camber and toe on the rear.

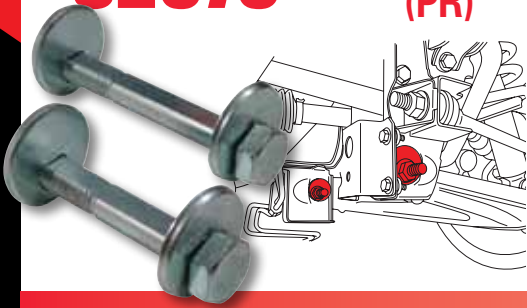

Front Adjustment range:

Camber $\pm 1.00^\circ$ Caster $\pm 1.00^\circ$

Rear Adjustment range:

Camber $\pm 1.00^\circ$ Toe $\pm 1.00^\circ$

Required: 1 per wheel/front
1 per wheel/rear

APPLICATIONS

Pontiac: 2006 - 10 Solstice
Saturn: 2007 - 10 Sky

82080 82085

GM REAR CAMBER & TOE BOLTS

Replace the factory torque-to-yield (TTY) rear camber and toe bolts on GM's Epsilon II platform with these hex chromate free 700 hour salt spray tested cam bolts from SPC. GM's hardware is TTY and needs to be replaced with every alignment. SPC's hardware can be re-torqued in future alignments, so you will only need to replace them once. These kits are sold per wheel and give you the same adjustment range as the factory cam, $\pm 2^\circ$ for camber or toe. You may find that the factory toe bolt (which is not TTY on hiper strut equipped models) is hard to reach, use SPC's D-Bolt socket, p/n 45938 to make adjusting the OE bolt easier.



82090



45938 - D-Bolt Socket for OE Bolt, pg 167

82080

Rear Adjustment range: Camber $\pm 2.0^\circ$

Required: 1 per wheel

82085

Rear Adjustment range: Toe $\pm 2.0^\circ$

Required: 1 per wheel

82080 & 82085 APPLICATIONS WITHOUT HIPER STRUT SUSPENSION

Buick: 2010 Allure; 2010 & LaCrosse
2011 - 17 Regal

82090

AWD OR FWD WITH HIPER STRUT

Rear Adjustment range:

Camber $\pm 2.00^\circ$ Toe $\pm 2.00^\circ$

Required: 1 per wheel

APPLICATIONS

Buick: 2010 Allure; 2010 & Up LaCrosse
2011 & Up Regal
Cadillac: 2013 & Up XTS

Rear Adjustment range:
Camber $\pm 2.00^\circ$ Toe $\pm 2.00^\circ$

Required: Camber **and** Toe
1 per wheel
Camber **or** Toe
1 kit per axle

APPLICATIONS

- Chevrolet:** 2004 - 12 Malibu
- Pontiac:** 2005 - 10 G6
- Saab:** 2003 - 12 9-3
- Saturn:** 2007 - 09 Aura

 **85130 - Rotary File Set, pg 173**

GM REAR CAMBER/TOE BOLTS (PR)

82100

Use this pair (2) of cam bolts to double the adjustment range for rear camber and toe on GM's Epsilon platform. The OE cams only give one degree of change which is often not enough camber and you may quickly run out of toe. The innovative design doubles change to $\pm 2.0^\circ$ and can be used as both camber and toe adjusters, as needed. Depending on how much change is required, you may need to use SPC's 85130 rotary file to elongate the adjustment slot to take full advantage of the max-offset cam. This kit has a hex chromate free finish that is highly corrosion resistant and meets industry leading 700-hour Salt Spray Test requirements (SST).

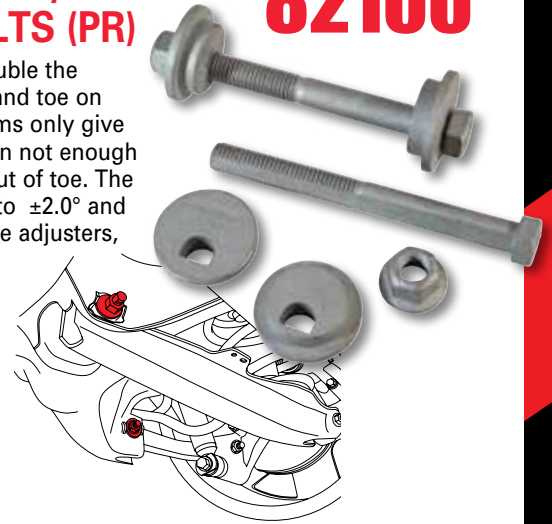

Competitor's Cam



Salt Spray Testing - Hex Chromate-Free Finish

- Hex Chromate-free finish for 700 hr salt spray results
- Avoids any hydrogen embrittlement issues
- Environmentally friendly

SPC's Cam



Rear Adjustment range:
Camber $\pm 2.00^\circ$ Toe $\pm 2.00^\circ$

Required: 1 per wheel

APPLICATIONS

- Buick:** 2007 - 17 Enclave
- Chevrolet:** 2008 - 17 Traverse
- GMC:** 2007 - 16 Acadia
2017 Acadia Limited
- Saturn:** 2007 - 2010 Outlook

GM SUV REAR CAM BOLT (PR)

82105

Replace your stripped or corroded factory adjusters on GM's Lambda platform vehicles with SPC's rear camber and toe adjustment bolts. This pair of camber bolts can be used to replace camber or toe bolts on either side of the car. You will need 2 kits to replace all four positions. This kit provides the same adjustment range as the factory cam bolts. Need front camber adjustment? The Lambda platform can use SPC's EZ Cams™ to add quick camber correction on the front suspension.

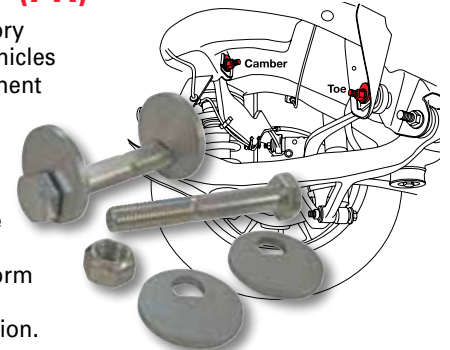

Rear Adjustment range:
Camber $\pm 2.00^\circ$

Required: 1 per wheel

APPLICATIONS

- Buick:** 2007 - 17 Enclave
- Chevrolet:** 2008 - 17 Traverse
- GMC:** 2007 - 16 Acadia
2017 Acadia Limited
- Saturn:** 2007 - 2010 Outlook

GM XAXIS™ AND CAM KIT

82106

Replace failed cross axis balljoints and frozen cam adjusters on the rear upper control arm of GM's popular Lambda platform vehicles with SPC's cam bolt and xAxis kit. This will let you adjust camber. Includes one xAxis joint and one cam bolt.

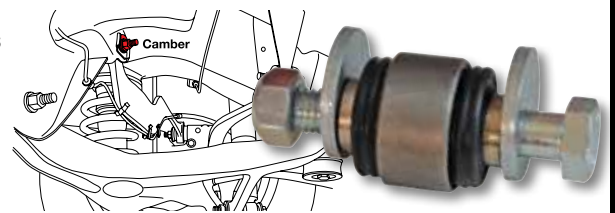

Front Adjustment range: Camber $\pm 2.50^\circ$

Required: 1 per axle

APPLICATIONS

See application charts, pages 7-64 for years.

- Buick:** Century, Skylark
- Chevrolet:** Celebrity, Citation, Lumina APV
- Olds:** Cutlass Ciera, Omega, Silhouette
- Pontiac:** *Front:* 6000, Phoenix *Rear:* Fiero, Trans Sport

 **85130 - Rotary File Set, pg 173**

GM CAMBER KIT (PR)

82110

This cam bolt kit changes camber up to $\pm 2.5^\circ$ positive or negative, when elongating the hole use our #85130 Rotary File Set.



Parts

Applications

Alignment Parts

Heavy Duty

OE Replacement

Racing/Builders

Tools

Brake and CV

Gear/Index

82120

CAMBER KIT (PR)

This cam bolt kit changes camber up to $\pm 2.5^\circ$. It includes an adjusting plate to make the camber adjustment possible. After elongating the lower strut/spindle bolt hole with a rotary file, install the **82120** bolt and plate, rotating the bolt head to the desired adjustment.

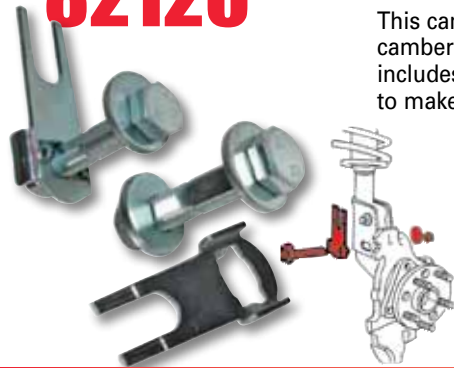

Front Adjustment range: Camber $\pm 2.50^\circ$

Required: 1 per axle

APPLICATIONS

See application charts, pages 7-70 for years.

Buick: Electra, Le Sabre, Park Avenue, Reatta, Regal, 95 Riviera, Skyhawk, Somerset **Cadillac:** Allante, Cimarron, Deville, Eldorado, Fleetwood, Seville, STS **Chevrolet:** Beretta, Camaro, Cavalier, Corsica, Lumina Sedan, Monte Carlo **Chrysler:** Concord, LHS, New Yorker **Dodge:** Intrepid, Monaco **Eagle:** Medallion, Premier, Vision **Ford/Lincoln/Mercury:** Cars with modified strut suspensions **Lexus:** ES250, ES300 **Oldsmobile:** Achieva, Aurora, Calais, Cutlass Supreme, Delta 88, Firenza, 98 Regency, Toronado, Trofeo **Pontiac:** Bonneville, Firebird, Grand Am, Grand Prix, J2000, Sunbird, Sunfire **Toyota:** Avalon, Camry, Previa



85130 - Rotary File Set, pg 173

82130

GM HIPER STRUT FRONT CAM BOLT SET (PR)

GM's HiPer strut has been released on several Buicks and Cadillacs. To adjust front camber you must adjust the cam bolt on the knuckle assembly. However, GM is using torque-to-yield bolts that require replacement whenever an alignment is performed. Replace the OE torque-to-yield bolts with SPC's upgraded bolts and you will not need to replace the bolt for future alignments. The kit includes 2 bolts; a cam bolt for the slotted upper hole and a standard replacement bolt for the lower hole, enough to align one corner.

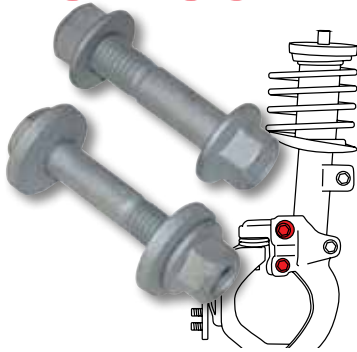

Front Adjustment range: Camber $\pm 2.0^\circ$

Required: 1 per wheel

APPLICATIONS with HiPer Strut

Buick: 2010 Allure
2016 & Up Cascada
2016 & Up Envision
2010 & Up LaCrosse
2011 - 17 Regal
Cadillac: 2014 - 16 ELR
2013 & Up XTS

Have a standard strut? See applications for the EZ Cam™ that fits your vehicle

82360

DODGE/JEEP FRONT CAMBER ADJUSTING KIT

Install this cam and guide kit to quickly and accurately dial in the camber angle on Grand Cherokees and Dodge Durangos. Even with the suspension loaded, this kit makes changes of up to $\pm 1.5^\circ$ camber fast and easy.

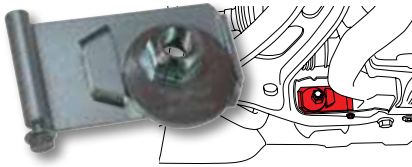

Front Adjustment range: Camber $\pm 1.50^\circ$

Required: 1 per wheel

APPLICATIONS

Dodge: 2011 - 18 Durango
Jeep: 2011 & Up Grand Cherokee

82365

DODGE/JEEP FRONT CAM./CAS. ADJ. KIT (PR)

Replace OE cams on the lower control arm of the 2002 to 2007 Jeep Liberty with this kit. Get the $\pm 1.5^\circ$ camber/ caster change that you need and lock it in with this simple R & R piece.

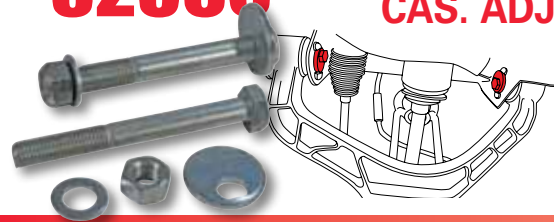

Front Adjustment range: Camber $\pm 1.50^\circ$ Caster $\pm 1.50^\circ$

Required: 1 per wheel

APPLICATIONS

Dodge FWD/4WD: 2007 - 12 Nitro
Jeep FWD/4WD: 2002 - 12 Liberty

82370

JEEP REAR PINION ANGLE ADJUSTING BOLTS (PR)

Correct rear pinion angle on Jeep TJs & ZJs by replacing the OE bolts on the upper trailing arms with these cam bolts.



64225 - Angle Gauge, pg 168

Rear Adjustment range: Pinion Angle $\pm 2.00^\circ$

Required: 1 per axle

APPLICATIONS

Jeep: 1993 - 98 Grand Cherokee (ZJ)
1997 - 06 Wrangler (TJ)

SPC has OE replacement and adjustable pin joints for many Dodge, Ram and Jeep applications, see page 78 for more.

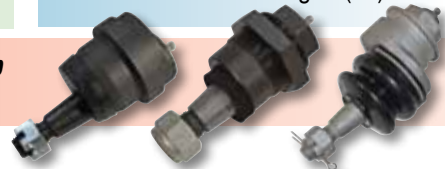

Front Adjustment range:
Caster $\pm 1.50^\circ$ Pinion $\pm 1.50^\circ$
Required: 1 per axle

APPLICATIONS

Jeep: 2018 & Up Wrangler (JL)
2020 & Up Gladiator

 **85130 - Rotary File Set,**
pg 173

JEEP JL FRONT CASTER/ PINION CAMS (PR)

Correct front pinion and caster issues on your stock or lifted Jeep with this adjustable cam kit from SPC. This kit is designed specifically for the new Jeep Wrangler JL and will provide $\pm 1.5^\circ$ of adjustment. You will need to slot the axle brackets to get the adjustment you need, use SPC rotary file set 85130 or similar.



NEW

Alignment Parts

Front Adjustment range:
Caster $\pm 1.50^\circ$ Pinion $\pm 1.50^\circ$
Required: 1 per axle

APPLICATIONS

Jeep: 2018 & Up Wrangler (JL)

 **85130 - Rotary File Set,**
pg 173

JEEP JL REAR PINION CAMS (PR)

Correct rear pinion angle issues on your stock or lifted Jeep with this adjustable cam kit from SPC. This kit is designed specifically for the new Jeep Wrangler JL will provide $\pm 1.5^\circ$ of adjustment. You will need to slot the holes on your axle brackets to get the adjustment you need, use SPC rotary file set 85130 or similar.



NEW

Heavy

Front/Rear Adjustment range:
Caster $\pm 1.50^\circ$ /Pinion Angle $\pm 1.50^\circ$
Required: 1 per axle

82380 APPLICATIONS

Jeep 4WD: 1997 - 06 Wrangler (TJ)
Dodge 4WD: *With 36mm cams*
1994 - 99 1500 Ram

82390 APPLICATIONS (Front & Rear)

Jeep RWD/4WD: 2007 - 18 Wrangler (JK)

 **74910 - Punch,** pg 173

JEEP CASTER/PINION ANGLE ADJUSTERS

These cams replace the front axle bolt to provide caster and pinion angle (up to $\pm 3^\circ$ total change). NOTE: Our #82380 is for 1997 - 06 Wrangler TJs, 1993 - 98 Grand Cherokees and 1994 - 98 Ram Trucks *with 36mm cams*.

To elongate OE bolt holes on the #82390 use our knock out punch - 74910. Front caster will change as you adjust pinion angle. Use our offset pin joints (23510-23540 - page 78) for additional caster adjustment and to adjust camber.

82380 82390

Check out
our JK
Suspension
Arms on
page 73



OE Replacement

Racing/Builders

Front Adjustment range:
Caster $\pm 2.00^\circ$ Pinion $\pm 2.00^\circ$
Required: 1 per axle

APPLICATIONS

Dodge 4WD: 2000 - 09 2500 Ram
2000 - 09 3500 Ram
2006 - 08 1500 Ram Mega Cab
Dodge RWD: 2000 - 09 3500 Ram
with mono beam

DODGE CASTER CAMS (PR)

Dodge solid front axled 3/4 and 1-ton trucks equipped with non-adjustable or corroded lower control arm bolts can now replace their OE bolts (*50mm cams*) with the 82385 Caster Adjustment Cam Kit. These replacement cam bolts provide caster and pinion adjustment up to $\pm 2.00^\circ$. Achieve desired alignment settings with or without suspension lift kits along with providing additional positive caster for improved tracking.

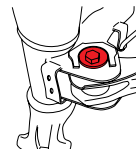

82385



Tools

Brake and CV

Front Adjustment range:
Caster $\pm 2.00^\circ$ Pinion $\pm 2.00^\circ$
Required: 1 per axle

82386 APPLICATIONS

Ram 4WD: 2010 - 13 2500; 2010 - 13 3500
Ram RWD: 2010 - 13 3500 with monobeam

82387 APPLICATIONS

Ram 4WD: 2014 & Up 2500; 2014 & Up 3500
Ram RWD: 2014 & Up 3500 with monobeam

HD RAM ADJ. CAM KIT (PR)

Replace frozen or worn lower control arm bolts with SPC's replacement adjusters. Designed for the rigors of Ram heavy duty trucks, these high strength bolts come with a corrosion resistant coating for long life. Adjust caster or pinion angle by $\pm 2.0^\circ$ to dial in your alignment settings or to correct for a suspension lift kit.

82386 82387



Gear/Index

Parts

82395

DODGE CASTER/PINION CAMS (PR)

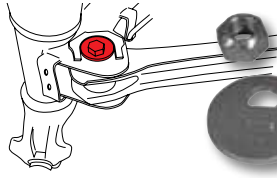

Replace the non adjustable or corroded OE bolts on Dodge 3/4 and 1-ton trucks to get $\pm 1.5^\circ$ of caster and pinion angle change. Whether the truck is lifted or stock ride height, optimize caster and pinion angles for better tracking and axle/drive shaft position.

Front Adjustment range:
Caster $\pm 1.50^\circ$ Pinion $\pm 1.50^\circ$

Installation time: .4 hr/axle

Required: 1 per axle

APPLICATIONS

Dodge 4WD:

1994 - 99 1500 Ram,
2500 Ram HD, 3500 Ram

Dodge RWD:

1994 - 99 3500 Ram with mono beam

82400

DODGE DAKOTA CAMBER/CASTER ADJUSTING KIT (PR)



Replace OE cams on the lower control arm of popular Dodge Dakota light trucks with this kit. Get the $\pm 2^\circ$ camber/caster change that you need and lock it in with this simple R&R piece.

Front Adjustment range:
Camber/Caster $\pm 2.00^\circ$

Installation time: .4 hr/axle

Required: 1 per wheel

APPLICATIONS

Dodge RWD/4WD: 2005-11 Dakota

Mitsubishi RWD/4WD:

2006 - 09 Raider

82420

DODGE 1500 CAM KIT (PR)



Replace corroded or damaged factory front camber and caster bolts on the Dodge 1500 with these hex chromate free 700 hour salt spray tested cam bolts from SPC. This kit is sold per wheel and gives you the same adjustment range as the factory cam, $\pm 2^\circ$ for camber and caster and is enough to replace the bolts on one lower control arm. If you need more change than the OE cams give you, use SPC's adjustable upper ball joint p/n 23940 (pg 78).

Front Adjustment range:
Camber/Caster $\pm 2.00^\circ$

Installation time: .4 hr/axle

Required: 1 per wheel

APPLICATIONS

Dodge/Ram RWD/4WD:

2006 & Up Ram 1500
Except Mega Cab

Ram RWD/4WD: 2011 & Up 1500

83115

CAM KIT (PR)



To correct camber remove the OE lower control arm attaching bolt and move arm away from the bracket. Using **73010** Punch, enlarge the hole in the bracket and re-attach the lower control arm using the correct mm bolt. To adjust, rotate the cam bolt.

Front Adjustment range: Camber $\pm .75^\circ$

Required: 1 per axle

APPLICATIONS

See application charts, pages 7-70 for years.

BMW: 1963 - 88 Vehicles w/14mm bolt

Datsun: 240Z, 260Z, 280Z, 810

Nissan: 200SX, 280ZX, 300ZX, Maxima



73010 - Punch,
pg 170

NOTE: Make sure bolt is long enough before cutting hole.

83160

CHRYSLER/FORD/GM OE REPLACEMENT CAMBER/CASTER KIT (PR)



These cams are used as an OE replacement on the front and/or rear of vehicles listed.

Required: 1 per wheel

APPLICATIONS

Front camber or caster Adjustment range: $\pm 2.00^\circ$

Chrysler: 1960 - 73 all cars

Dodge: 1960 - 73 all cars (except B & E bodies); 1972 - 89 AD150

1972 - 87 D100, D150, D200, D250. D300, D350, D400, D450

1974 - 87 Ramcharger

Plymouth: 1960 - 73 all cars; 1974 - 81 Trailduster

Front camber Adjustment range: $\pm 2.00^\circ$

Ford: 1966 - 70 Fairlane, Falcon; 1966 - 71 Torino

1967 - 73 Mustang; 1967 - 79 Maverick

Mercury: Cougar 1967 - 79; 1966 - 70 Montego; 1967 - 79 Comet

1975 - 80 Granada/Monarch

Rear camber Adjustment range: $\pm 2.00^\circ$

Chevrolet: Corvette 1963 - 82

Front Adjustment range: Camber $\pm 2.50^\circ$

Required: 1 per axle

APPLICATIONS

Chrysler/Dodge/Plymouth:

1996 & up Mini-Vans (Caravan, Town & Country, Voyager), 2012 - 13 Tradesman Conv. Van 1980 - 95 FWD 400, 600, Acclaim, Aries, Caravelle, Charger, Daytona, Dynasty, E Class, Fifth Ave., Imperial, Horizon, Lancer, New Yorker, Omni, Rampage, Reliant, Scamp, Shadow, Spirit, Sundance, TC3, Turismo **Volkswagen:** 2009 - 14 Routan

Check out what else this cam set can do! See page 117.

FRONT CAMBER KIT (PR)

83170

These heavy duty adjusters provide up to $\pm 2.5^\circ$ front camber change for Chrysler/Dodge/Plymouth Mini-Vans and FWD cars along with VW Routans.



85130 - Rotary File Set, pg 173



83180 Front Adjustment range: Camber/Caster $\pm 2.0^\circ$
Rear Adjustment range: Camber/Toe $\pm 2.0^\circ$

83185 Front Adjustment range: Camber/Caster $\pm 1.0^\circ$

Required: 1 per wheel

APPLICATIONS

83180 Mazda: 1990 - 05 Miata (MX-5)

83185 Mazda: 2006 - 15 Miata (MX-5)

MAZDA MIATA MX-5 CAMBER/CASTER ADJUSTING KIT (PR)

83180 83185

Use this kit to replace stripped or bent OE alignment cam assemblies on later generations of the Mazda Miata MX-5. SPC's cams are heat treated to prevent stripping or warping. The kit is available per wheel and allows full use of the factory adjustment range.



Front Adjustment range: Cam/Cas $\pm 1.25^\circ$

Required: 1 per wheel

APPLICATIONS

Chevrolet 4WD: 1982 - 04 Blazer, S-10

GMC 4WD: 1982 - 04 Jimmy, Sonoma

Isuzu 4WD: 1996 - 00 Hombre

Oldsmobile 4WD: 1991 - 01 Bravada

CHEVY/GMC CASTER/CAMBER ADJ. KIT (PR)

83710

The 83710 is an OE replacement cam and bolt kit for the popular 4WD Chevy S-10/ Blazer and GMC Sonoma/ Jimmy. Adjust $\pm 1.25^\circ$ camber and caster with this simple to use set-up.



Front Adjustment range: Cam/Cas $\pm 2.00^\circ$

Required: 1 per wheel

APPLICATIONS

Cadillac/Chevrolet/GMC

AWD: 1990 - 05 Astro/Safari Van

4WD: 1988 - 00 1500, 2500, 3500 (99-00 Classic Only)

RWD/ 1992 - 94 Blazer (full size)

4WD: 1988 - 91 Jimmy (full size)

1999 - 00 Escalade; 1992 - 99 Yukon

1992 - 99 Suburban; 1995 - 99 Tahoe

RWD: 1996 - 02 Express/Savana

GM HEAVY DUTY CAM/CAS KIT (PR)

83790

These heavy duty cam bolts replace the upper control arm mounting bolts. This kit has convenient slip-on cams which makes installation easier. Remove the OE bolts and replace them with these cams, rotating to provide camber and caster adjustment. Use **74910** punch to remove the OE slugs and elongate the holes. **87400** includes 4 cam and bolt assemblies to cover both sides of the vehicle (page 132).



74910 - Punch, pg 170

Rear Adjustment range: Toe $\pm .75^\circ$

Required: 1 per wheel

84080 APPLICATIONS

Hyundai: 2013 - 15 Azera; 2011 - 14 Sonata 2010 - 15 Tucson (FWD)

Kia: 2016 - Cadenza; 2011 - 15 Optima

2011 - 16 Optima Hybrid; 2011 - 16 Sportage (FWD)

84085 APPLICATIONS

Hyundai: 2016 & Up Santa Fe Wagon; 2015 & Up Sonata 2016 - 18 Tucson FWD; 2010 - 18 Tucson AWD

Kia: 2017 & Up Cadenza; 2015 & Up K900

2016 & Up Optima; 2015 & Up Sedona; 2016 & Up Sorrento

2017 & Up Sportage; 2018 & Up Stinger

HYUNDAI/KIA REAR TOE CAM

84080 84085

Quickly restore lost adjustment due to frozen or broken adjusters with this rear toe adjustment cam from SPC. This cam is designed to fit a wide variety of late model Hyundai and Kia vehicles and is sold per wheel. Order two kits to replace the toe adjusters on both sides of the vehicle.



NEW

Gear

Applications

Alignment Parts

Heavy Duty

OE Replacement

Racing/Builders

Tools

Brake and CV

Parts

HYUNDAI/KIA REAR CAMBER CAMS

Quickly restore lost adjustment due to frozen or broken adjusters with this rear camber adjustment cam from SPC. This cam is designed to fit a wide variety of late model Hyundai and Kia vehicles and is sold per wheel. Order 2 cams to service both sides of your vehicle.

Rear Adjustment range: Camber $\pm 0.75^\circ$

Required: 1 per wheel

APPLICATIONS

Hyundai: 2005 - 17 Azera; 2007 - 19 Sonata
2013 - 18 Santa Fe; 2010 - 18 Tucson
2014 - 19 Cadenza; 2015 - 19 K900
2011 - 19 Optima; 2015 - 19 Sedona
2011 - 19 Sorento; 2011 - 19 Sportage

Alignments

Alignment Parts

Heavy Duty

OE Replacement

Racing/Builders

Tools

Brake and CV

Gear/Index



84100

HYUNDAI/KIA REAR ADJ. CAMS

Replace damaged or corroded factory alignment adjusters on the rear suspension of many Hyundai and Kia SUV models with these cam bolts from SPC. These bolts are designed to provide the same adjustment range as the original components while providing superior corrosion and salt resistance with SPC's 700 hour salt spray tested coating. This kit includes two bolts: a replacement camber bolt and toe bolt to restore adjustability for one side of the vehicle. Order two kits to restore adjustment to the entire rear suspension.

Rear Adjustment range:

Camber $\pm 1.5^\circ$ Toe $\pm 1.5^\circ$

Required: 1 per wheel

APPLICATIONS

Hyundai: 2007 - 12 Santa Fe
2007 - 12 Veracruz
Kia: 2008 - 11 Borrego
2011 - 13 Sorento

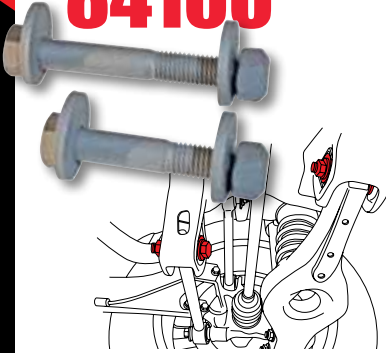

84120

SEDONA/ENTOURAGE REAR CAM BOLTS

Adjust Entourage and Sedona rear camber with SPC's patented camber bolt. Simply replace the rear lower control arm to knuckle bolt with SPC's bolt and get $\pm 0.75^\circ$ camber change to get the vehicle back to specification.

Rear Adjustment range:

Camber $\pm 0.75^\circ$

Required: 1 per wheel

APPLICATIONS

Hyundai: 2007 - 09 Entourage
Kia: 2006 & Up Sedona

US Patent Nos. 8,544,861 • 8,469,375 • D783,393
China Patent No. 201630012294.X



84130

TAURUS PLATFORM REAR CAMBER KIT

Adjust rear camber on many non-adjustable Ford and Lincoln models with SPC's patented EZCam™ Bolt. Simply replace the rear upper control arm to knuckle bolt with SPC's bolt and get $\pm 0.75^\circ$ of camber adjustment to bring your vehicle back into specification.

Rear Adjustment range:

Camber $\pm 0.75^\circ$

Required: 1 per wheel

APPLICATIONS

Ford: 2010 & Up Taurus
2009 & Up Flex
2011 & Up Explorer
Lincoln: 2009 - 16 MKS
2010 & Up MKT

US Patent Nos.
8,544,861 • 8,469,375 •
10,450,005 • D783,393
China Patent No.
201630012294.X

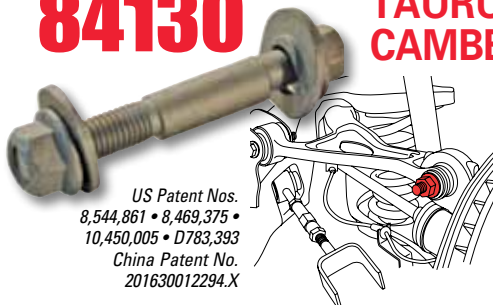

84690 84695

HONDA CASTER SPACERS

These spacers change caster approximately $1/8^\circ$ (84690 - 1/16" thick) and $1/4^\circ$ (84695 - 1/8" thick). Adding spacers between the strut rod assembly and the large washer repositions the lower control arm to decrease caster. Removing them increases caster. Each part number comes in a package of ten.

Front Adjustment range:

Caster -1.25° to -0.25°

Required: 1 spacer per wheel

APPLICATIONS

Acura: 1997 - 99 CL; 1996 - 03 TL
1992 - 94 Vigor
Honda: 1990 - 02 Accord
1995 - 98 Odyssey

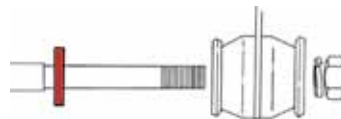

84690
1/16" thick

84695
1/8" thick

Front Adjustment range:
Camber $\pm 75^\circ$ /Caster $\pm 1.25^\circ$

Required: 1 per axle

APPLICATIONS

- Ford:** 2002 - 05 Explorer
- Lincoln:** 2003 - 05 Aviator
- Mercury:** 2002 - 05 Mountaineer



EXPLORER/MOUNTAINEER FRONT CAM./CAS. KIT

86140

Caster and camber adjustments can be made easily by installing this kit. By replacing the stock alignment washers on the upper control arms, caster and camber can be adjusted by turning the cam nuts to obtain the proper readings. These cam kits give you the full range of caster and camber adjustment and can make alignment changes for the life of the vehicle.



Rear Adjustment range:
Camber $\pm 50^\circ$

Required: 1 per axle

APPLICATIONS

- Ford:** 2002 - 05 Explorer
- Lincoln:** 2003 - 05 Aviator
- Mercury:** 2002 - 05 Mountaineer

EXPLORER/MOUNTAINEER REAR CAMBER KIT

86180

This camber adjuster lets you easily adjust camber on the Explorer/Mountaineer fully independent rear suspension systems. Full range of camber adjustment can be made by replacing the stock alignment washer on the rear lower control arm and installing the plate and cam nut. Camber can then be adjusted by turning the cam nut until the desired readings are obtained.



Front Adjustment range:
Camber $\pm 1.00^\circ$ Caster $\pm 1.50^\circ$

Required: 1 per wheel

APPLICATIONS

- Ford RWD/4WD:** 2007 - 17 Expedition, 2004 & Up F150, 2010 & Up Raptor
- Lincoln:** 2006 - 08 Mark LT, 2007 - 17 Navigator



FORD ADJUSTABLE CAM NUT/BACKET (PR)

86250

The innovative cam nut and sturdy bracket saves time and money. Easily adjust camber and caster on F150's and Expeditions. Save time since you don't have to remove the OE bolt or stabilizer bar. The sturdy guide bracket allows for live adjustment on the lower control arm. This product is a must have every time these vehicles enter your shop!



Front Adjustment range:
Camber $\pm 1.00^\circ$ Caster $\pm 1.50^\circ$

Required: 1 per wheel

APPLICATIONS

- Ford RWD/4WD:** 2007 - 17 Expedition, 2004 & Up F150, 2010 & Up Raptor
- Lincoln:** 2006 - 08 Mark LT, 2007 - 17 Navigator



RAPTOR & F150 HD CAM FRONT CAM/CAS KIT (PR)

86252

This heavy-duty cam-bolt kit was specifically designed for the extreme Raptor and F-150 user. Whether you are an energetic Raptor driver or abuse your F-150 in the fields and on the job site, you may have found that the OE bolts slip or that a single cam option does not hold alignment. This upgraded cam kit features two cams and bosses per bolt. The two cams will keep your bolt square and make adjustment easier while the new bolt and low friction finish achieve 25% more clamp load than the OE hardware. Some drilling is required to accommodate the second boss plate. This kit is sold per wheel and fits Raptors, non-Raptor F-150's and related SUVs.

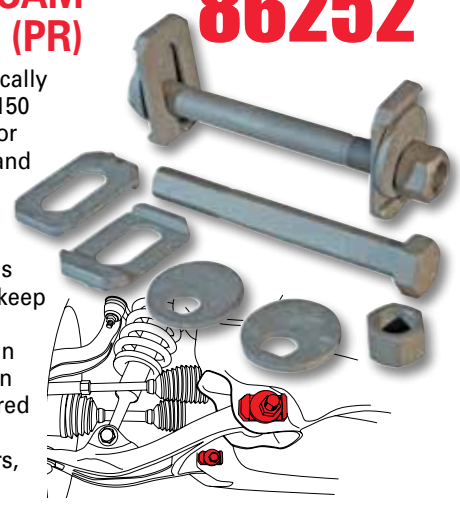

SPC also carries an adjustable upper control arm for late and current models of the popular F150. Part No. 25680 (page 82) is perfect for ride height altered vehicles with the ability to achieve greater droop travel, move oversized tires in the wheel well and improve drivability and tracking.

Parts

86255

F150 PINION ANGLE SHIMS (PR)

This wedge-type shim fits the 2 hole design of this platform between the rear spring and the axle to change pinion angle. Perfect to align the driveline on vehicles that have been lowered or lifted.



Rear Adjustment range: Pinion $\pm 2.50^\circ$

Required: 1 per axle

APPLICATIONS

Ford: 2004 & Up F150



64225 - Angle Gauge, pg 168

86320 86321

GM ALIGNMENT CAM LOCK PLATE (PR)

This lock plate is designed to keep the front alignment angles in position by replacing the existing slotted cam. Simply replace the slotted cam with this indexed cam and you will be locked in.

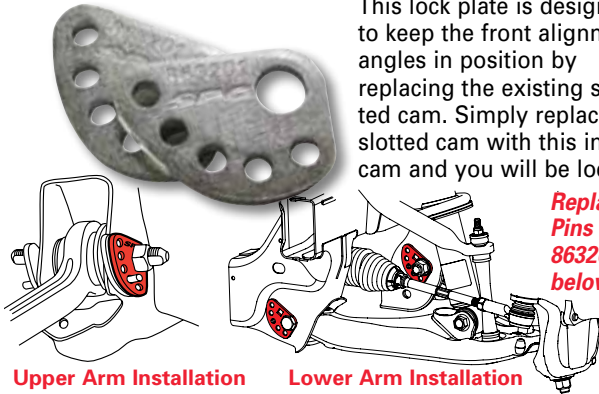

Upper Arm Installation

Lower Arm Installation

Replacement Pins #86325, 86326 - below

Locks in OE adjustment

Required: 1 per wheel

86320 APPLICATIONS

Cadillac RWD/4WD: 2002 & Up Escalade

Chevrolet/GMC RWD/4WD: 1999 & Up 1500 & 1500HD Crew Cab; 1999 - 10 2500, 3500; 2002 - 13 Avalanche 1500, 2500; 2004 - 12 Canyon & Colorado 2003 - Up Express/Savana Van; 2000 & Up Suburban, Tahoe, Yukon, Yukon XL (1500, 2500)

Hummer AWD: 2002 - 09 H2; 2006 - 10 H3, H3T

86321 APPLICATIONS

Upper Arm: Chevrolet/GMC RWD/4WD: 2011 & Up 2500HD, 3500HD

Lower Arm: Chevrolet RWD/4WD: 2015 & Up Colorado
GMC RWD/4WD: 2015 & Up Canyon

86325 86326

GM ALIGNMENT PINS (8)

Replace bent, damaged or lost factory guide pins with these heavy duty knurled pins from SPC and your slotted cam will work like it should again. Every tech needs to have these easy to use pins on the shelf, ready to install, for GM 1500s, 2500s or Colorados.



Includes 8 pins

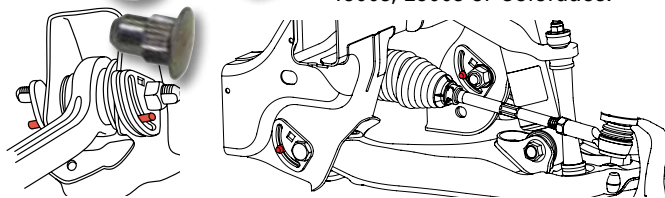

Upper Arm Installation

Lower Arm Installation

Front Replacement Part:

8 pins per package

86325 APPLICATIONS

Cadillac RWD/4WD: 2002 & Up Escalade

Chevrolet/GMC RWD/4WD: 1999 & Up 1500 & 1500HD Crew Cab; 1999 - 10 2500, 3500; 2002 - 13 Avalanche 1500, 2500; 2004 - 12 Canyon & Colorado 2003 - Up Express/Savana Van; 2000 & Up Suburban, Tahoe, Yukon, Yukon XL (1500, 2500)

Hummer AWD: 2002 - 09 H2; 2006 - 10 H3, H3T

86326 APPLICATIONS

Upper Arm: Chevrolet/GMC RWD/4WD: 2011 & Up 2500HD, 3500HD

Lower Arm: Chevrolet RWD/4WD: 2015 & Up Colorado
GMC RWD/4WD: 2015 & Up Canyon

Specialty Products Works!

SPC parts and tools are used in commercial fleets worldwide. Fleet specialists know that aligning their vehicles correctly prolongs tire life, increases fuel mileage and improves handling and tracking.

Check out SPC's FasTrax™ Alignment Gauge (pages 149 & 176). By adding just 5 minutes to your PM schedule you can protect your tires from premature wear and increase fuel mileage.



Front Adjustment range: Camber $\pm 1.00^\circ$

Required: 1 per wheel

86330 APPLICATIONS

Chevrolet/GMC RWD/4WD:

2001 - 06 1500HD Crew Cab; 1999 - 10 2500, 3500
2002 - 06 Avalanche 2500; 2000 - 14 Suburban 2500
2000 - 14 Yukon XL 2500

Hummer AWD: 2002 - 09 H2



86350 APPLICATIONS

Cadillac RWD/4WD: 2002 & Up Escalade

Chevrolet/GMC RWD/4WD: 1999 - 18 1500

1988 - 00 1500, 2500, 3500 (1999-00 'Classic' only)
2002 - 13 Avalanche 1500; 1992 - 94 Blazer (full size)
2003 & Up Express/ Savana Van
1988 - 91 Jimmy (full size); 1992 & Up Suburban 1500
1995 & Up Tahoe; 1992 & Up Yukon

GM RWD/4WD FRONT CAMBER BUSHINGS (PR)

86330 86350

Replace the upper OE bushings with these offset control arm bushings to get $\pm 1.0^\circ$ of additional camber change. OE style rubber maintains the original ride characteristics.



72509 - Ball Joint Press, pg 169

Front Adjustment range:

Camber $\pm 1.50^\circ$ /Caster $\pm 1.50^\circ$

Required: 1 per wheel
(2 Cams in kit)

APPLICATIONS

Chevrolet: 2004 - 12 Colorado

GMC: 2004 - 12 Canyon

Hummer: 2006 - 10 H3, H3T

Isuzu: 2006 - 08 i350/i370

GM MID-SIZED CAMS (PR)

GM's late-model mid-sized 4WD's have very little clearance to adjust the camber and caster with the OE adjusting cams. These specially designed adjusters replace the OE adjusters, and feature a 3/8" square drive hole, allowing fast and easy "on-the-vehicle" adjustments with any standard breaker bar. The unique design saves time by installing onto the OE bolt - no need to replace the bolt - and allows for quick future adjustments.

Replacement Pins #86325 - Previous Page

86360



Front Adjustment range:

Camber $\pm 1.50^\circ$ /Caster $\pm 1.50^\circ$

Required: 2 per wheel
(1 Cam in kit)

APPLICATIONS

Chevrolet/GMC RWD/4WD:

2003 & Up Express & Savana Van

*Replacement Pins #86325
Previous Page*

GM VAN ALIGNMENT CAM PLATE (EACH)

Designed to be easily adjusted with a 3/8" drive breaker bar, this cam makes the difficult to align 2003 and up GMC Savana and Chevy Express Vans a snap. Simply replace the OE cam on the forward bushing with this cam and you will be able to dial in camber and caster. This cam can also be used as a replacement cam for 1999 & up full size Chevrolet/GMC Trucks and SUVs.

86370

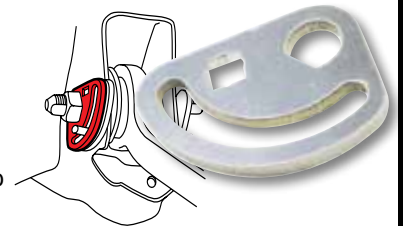

GM REPLACEMENT FRONT ALIGNMENT PLATE AND CAM (PR)

Front Adjustment range: Camber/Caster $\pm 1.50^\circ$

Required: 1 per wheel

86375 APPLICATIONS

Cadillac RWD/4WD: 2002 & Up Escalade

Chevrolet/GMC RWD/4WD: 1999 - 18 1500 & HD Crew Cab; 1999 - 10 2500, 3500; 2002 - 13 Avalanche 1500, 2500; 2004 - 12 Canyon & Colorado
2003 - Up Express/Savana Van; 2000 & Up Suburban, Tahoe, Yukon, Yukon XL (1500, 2500)

Hummer AWD: 2002 - 09 H2; 2006 - 10 H3, H3T

86376 APPLICATIONS

Upper Arm: **Chevrolet/GMC RWD/4WD:**
2011 & Up 2500HD, 3500HD

Lower Arm: **Chevrolet RWD/4WD:**

2015 & Up Colorado **Replacement Pins #86325 & #86326 - Previous Page**
2015 & Up Canyon

The **86375** kit is a stock OE replacement cam/bolt kit for newer GM 1/2, 3/4, and 1 ton truck and van applications. The **86376** kit is a stock OE replacement cam/bolt kit for newer GM heavy duty applications. These kits are for camber and caster adjustment. Fast, simple installation. For additional change for the 1/2, 3/4 and 1 ton vehicles see our bushings **86330** & **86350** (above) or our adjustable ball joint **23960** (page 80).

86375 86376



Lower Arm Installation

Upper Arm Installation

Applications

Alignment Parts

Heavy Duty

OE Replacement

Racing/Builders

Tools

Brake and CV

Gear/Index

Parts

86470

GM FRONT CONTROL ARMS



Get your GM Truck or SUV's front caster back in spec with these fixed offset upper control arms. Whether you lift your rig 3" or lower it 1" the caster will be out of factory specifications. The OE adjusters do not provide enough change, so install SPC offset upper arms for 2° caster change and then use the OE cams to dial in your alignment and get drivability back.

Kit includes arms for both the right and left hand side. It can be used for lifted and lowered applications, if you drop your ride height more than 1" it will start to gain caster very quickly. These arms will still work for you, swap these arms left to right and get -2° caster change if you need it.

These arms feature:

- Full forged construction for maximum strength.
- Booted and greasable ball joints.
- **SPC's xAxis™ technology with a twist.** The xAxis sealed flex joints used in these arms provide a free pivot for droop and misalignment so that OE caster and camber adjustments will not bind the joint. These joints also have rubber isolation to retain OE levels for Noise, Vibration, and Harshness (NVH).

Front Adjustment range:

Caster +2.00° **Fixed**

Required: 1 per axle

APPLICATIONS

Cadillac RWD/4WD:

2002 - 06 Escalade

Chevrolet/GMC RWD/4WD:

2002 - 06 Avalanche 1500

1999 - 06 Silverado 1500

2000 - 06 Suburban 1500

2000 - 06 Tahoe

GMC RWD/4WD:

1999 - 06 Sierra 1500

2000 - 06 Yukon 1500 inc. XL

Need to replace the OE adjusters? Consider SPC's #86375 replacement cams (pg. 129), #86325 replacement alignment pins (pg. 128) and #86320 alignment locking plates (pg. 128).

86490

COLORADO/CANYON FRONT UPPER ADJ. ARMS (PR)

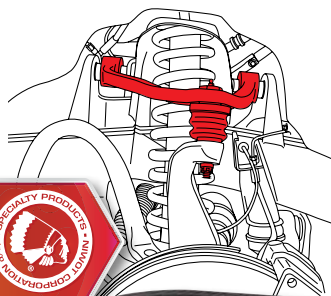

Improve droop travel, drivability and tire wear as well as adjusting tire position in your wheel well with SPC's adjustable front upper control arms. Featuring an upgraded greasable ball joint and rubber isolated xAxis™ bushings, this arm is designed to correct alignment angles while maintaining factory ride quality. SPC's fully forged steel design provides the strength and durability needed for the most demanding environments. These remove and replace arms are sold in pairs.

Improve droop travel, drivability and tire wear as well as adjusting tire position in your wheel well with SPC's adjustable front upper control arms. Featuring an upgraded greasable ball joint and rubber isolated xAxis™ bushings, this arm is designed to correct alignment angles while maintaining factory ride quality. SPC's fully forged steel design provides the strength and durability needed for the most demanding environments. These remove and replace arms are sold in pairs.

- **Get more droop travel:** Don't let OE ball joints or mono-ball articulation limit your travel. SPC joints are oversized and provide 80° of travel.

- **Get your drivability and tracking back:** Your truck may have started to 'wander' after you lifted it. That is because you lost caster. Install SPC arms and get your 'drivability' back by putting your alignment in specification.
- **Get your tire where you want it in the wheel well:** Are your oversized tires rubbing the fenders or frame rails? SPC Adjustable Arms, in combination with OE adjustments on the lower arm, allow you to dial in alignment specs at the same time that you move the tire forward/outward in the wheel well by up to 1".

Isolated xAxis™ Sealed Flex Joint Bushings

- Booted to keep contaminants out
- Free pivoting to eliminate binding
- **Bonded Rubber Sleeve** To minimize Noise, Vibration, and Harshness (NVH)

Designed, engineered, tested, and assembled in Colorado, SPC has stepped it up again.

- Strongest arm available
- Most articulation of any arm, period
- The only bootted adjustable ball joint on the market
- Maintenance free pivoting bushing

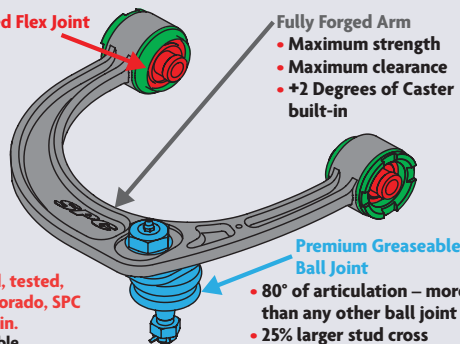

- **Fully Forged Arm**
- Maximum strength
- Maximum clearance
- +2 Degrees of Caster built-in

Premium Greasable Ball Joint

- 80° of articulation – more than any other ball joint
- 25% larger stud cross section vs OE
- Greasable with sealed boot

Front Adjustment range:

Camber ±2.0°

Caster 0° to +4.0°

Required: 1 per axle

APPLICATIONS

Chevrolet: 2015 & Up Colorado

GMC: 2015 & Up Canyon

Need to replace the lower arm adjusters? Consider SPC's #86376 replacement cams (pg. 129), #86326 replacement alignment pins (pg. 128) and #86321 alignment locking plates (pg. 128).

Patent No. US 7,513,514

Front Adjustment range:
Camber $\pm 1.00^\circ$ /Caster $\pm 1.50^\circ$

Required: 1 per wheel

APPLICATIONS

Ford: 2003 - 06 Expedition
Lincoln: 2003 - 06 Navigator

FRONT CAMBER/CASTER EXPEDITION KIT

86640

This kit allows for easy adjustment of the lower control arm to make camber and caster changes. Uses the OE bolts with the new cams and adjusting plates to give you lifetime camber and caster adjustments.



83820 - Adjusting Wrench, pg 172



Rear Adjustment range:
Camber $\pm 1.00^\circ$

Required: 1 per wheel

APPLICATIONS

Ford: 2003 - 06 Expedition
Lincoln: 2003 - 06 Navigator

REAR CAMBER EXPEDITION KIT

86680

This rear camber kit replaces the bolt on the upper control arm near the wheel. The adjusting plate locks into existing holes in the rear knuckle assembly making this a very easy-to-use and time saving kit.



Rear Adjustment range:
Camber $\pm 1.50^\circ$

Required: 1 per wheel

APPLICATIONS

Ford: 2007 - 17 Expedition
Lincoln: 2007 - 17 Navigator

REAR CAMBER EXPEDITION KIT

86690

Quickly and easily adjust rear camber with this cam and bracket kit designed for the Ford Expedition. This kit makes the factory camber adjustment much more simple and secure to dial in exactly where you need it and features a 700 hr salt spray tested coating for corrosion resistance and long service life. Just one kit is needed to service both sides of the vehicle. Need to add more camber adjustment? Consider our adjustable rear camber arm, SPC PN 67275 (page 90).

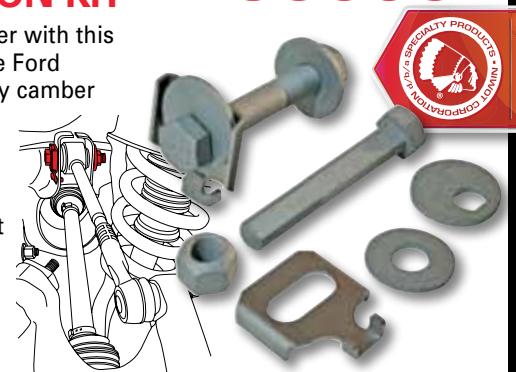

Front Adjustment range: Caster $\pm 2.00^\circ$

Required: 1 per axle

APPLICATIONS

Ford RWD: 1987 - 98 F250; 1987 - 98 F350
1989 - 97 Ranger
Mazda RWD: 1994 - 97 'B' Series Pickup
1991 - 94 Navajo



FORD TRUCK RWD CASTER KIT (PR)

87280

This part fits many Ford truck and vans with 20mm bolts. With this kit you can adjust caster up to $\pm 2.0^\circ$.



Front Adjustment range:
Camber $\pm 1.75^\circ$ /Caster $\pm 1.75^\circ$

Required: 1 per axle

APPLICATIONS

Ford RWD/4WD: 1995 - 01 Explorer
2001 - 05 Explorer Sport Trac
1998 - 00 Ranger
Mercury RWD/4WD: 1996 - 01 Mountaineer

EXPLORER CAMBER/CASTER KIT (4)

87310

This set of 4 cams allows for quick installation without having to remove the upper control arm bolt. Change camber and caster up to $\pm 1.75^\circ$.

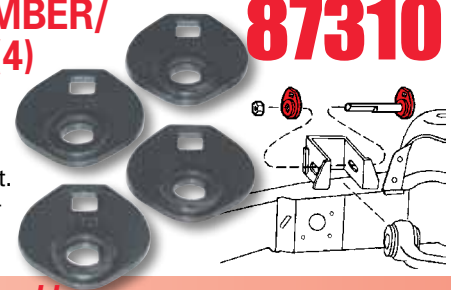

Exporting around the world

Specialty Products exports parts and tools throughout the world. Vehicles that are introduced abroad often end up in the US within a few years. With our export and international partners, SPC is able to develop parts and tools for world platform vehicles before they arrive in the US.

Parts

87330

TAURUS/SABLE SEDAN REAR CAMBER-TOE KIT (4)



To change rear camber and toe on 1986 - 06 Taurus and Sable sedan, use our kit which allows up to $\pm 1.0^\circ$ change in camber and 1.0° toe change. Remove the OE bushings and toe adjusters on the inner pivot points and replace with the eccentric bushings. Rotate the bushings to adjust camber and/or toe.

Rear Adjustment range:
Camber $\pm 1.00^\circ$
Toe $\pm 1.00^\circ$



Required: 1 per axle

APPLICATIONS

Ford: 1986 - 07 Taurus Sedan
Mercury: 1986 - 06 Sable Sedan



8370 - Tie Rod Puller, pg 163
87320 - Bushing Adj. Tool, pg 173

Applications

Alignment Parts

Heavy Duty

OE Replacement

Racing/Builders

Tools

Brake and CV

Gear/Index

87350

TAURUS/SABLE WAGON REAR CAMBER KIT (PR)



This kit provides camber change up to $\pm 2.50^\circ$ on each rear wheel of Ford Taurus and Mercury Sable Station Wagons only. After replacing the inner lower control arm bolt and elongating the hole, install the 87350 cam bolt and rotate the head to adjust camber.



85130 - Rotary File, pg 173

Rear Adjustment range:
Camber $\pm 2.50^\circ$

Required: 1 per axle

APPLICATIONS

Ford: 1986 - 05 Taurus Station Wagon
Mercury: 1986 - 05 Sable Station Wagon

Heavy Duty

87365

FORD, MERCURY, LINCOLN CAMBER ADJ. BOLT

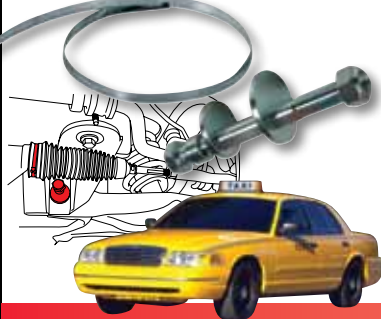

The 87365 Adjustable Camber Kit allows additional camber changes up to $\pm 1.5^\circ$ for a total of $\pm 2.5^\circ$, on the popular Ford Crown Victoria, Mercury Marquis, and the Lincoln Town Car. Sagging of the suspension on these heavyweight vehicles is normal and routinely causes negative camber problems. Elongating the cam slots is completed in seconds using the new 85137 3/8" Rotary File for Aluminum.

Front Adjustment range:
Camber $\pm 2.5^\circ$

($\pm 1.5^\circ$ more than stock change)

Required: 1 per wheel

APPLICATIONS

Ford: 2003 -12 Crown Victoria
Lincoln: 2003 -11 Town Car
Mercury: 2003 -11 Grand Marquis
2003 - 04 Marauder



85130 - Rotary File, pg 173
02099 - Boot Clamp, pg 180

OE Replacement

Racing/Builders

87385

F150/F250 (L/D) CAM/ CAS KIT (4)



Use this kit to change caster and/or camber on these unadjustable vehicles. Simply replace the existing upper control arm mounting bolts with these cam bolts for caster/ camber changes up to 2.0° .

Front Adjustment range:
Camber $\pm 2.00^\circ$ /Caster $\pm 2.00^\circ$

Required: 1 per axle

APPLICATIONS

Ford RWD/4WD: 1997 - 02 Expedition
1997 - 03 F150
2004 - 05 F150 Heritage
1997 - 99 250 (LD)
Lincoln RWD/4WD: 2002 - 03 Blackwood
1998 - 02 Navigator

Tools

Brake and CV

87400

GM RWD/4WD CAM/ CAS KIT (4)



These heavy duty cams replace the upper control arm mounting bolts. Remove the OE bolts and replace with cams, rotating to provide camber and/or caster adjustment. It may be necessary to remove OE slugs and elongate the bolt holes with 74910 punch. 83790 includes 2 cams to cover one side of the vehicle (page 135).



74910 - Punch, pg 170

Front Adjustment range:
Camber $\pm 2.00^\circ$ /Caster $\pm 2.00^\circ$

Required: 1 per axle

APPLICATIONS

Cadillac/Chevrolet/GMC
AWD: 1990 - 05 Astro/Safari Van
4WD: 1988 - 00 1500, 2500, 3500
(1999-00 Classic Only)
RWD/4WD: 1992 - 94 Blazer (full size)
1999 - 00 Escalade; 1988 - 91 Jimmy (full size)
1992 - 99 Suburban/Yukon; 1995 - 99 Tahoe
RWD: 1996 - 02 Express/Savana Van

Rear Adjustment range:
Camber/Toe $\pm 1.00^\circ$
Required: 1 per wheel

APPLICATIONS

- Chevrolet/GMC:**
2012 - 15 Captiva Sport
2005 - 17 Equinox
2005 - 17 Terrain
- Pontiac:** 2006 - 09 Torrent
Saturn: 2006 - 09 Vue
Suzuki: 2007 - 11 XL-7

GM REAR TOE KIT

87420

Change Toe or Camber $\pm 1^\circ$ on the rear of GM's Theta Platform vehicles with this cam nut. Easily make the adjustment you need by installing this cam nut on the toe link's bolt and then driving change in combination with a cam nut on the camber link. (Note: Most vehicles come with a cam nut on the 'camber link' and a standard, non-offset, nut on the 'toe link.' Changing toe will affect camber and vice versa.) If the camber cam nut is corroded or missing, use this cam nut in that position as well. You may need up to four (4) cam nuts per vehicle.



Rear Adjustment range:
Camber $\pm 1.00^\circ$ Toe $\pm 2.00^\circ$
Required: 1 per wheel

APPLICATIONS

- Chevrolet:** 2010 - 15 Camaro
2011 - 17 Caprice PPV
2014 - 17 SS
- Pontiac:** 2008 - 09 G8

CHEVY CAMARO/PONTIAC G8 ADJ. REAR CAM (PR)

87430

Double the range of rear camber and toe adjustment on the popular Camaro to increase handling performance and minimize tire wear. Remove and replace the OE cam bolts with our 87430 kit for $\pm 1.0^\circ$ camber change and $\pm 2.0^\circ$ toe change. No slotting or grinding needed!

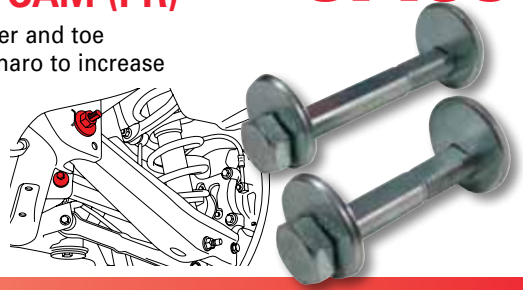

Front Adjustment range:
Camber $\pm 2.00^\circ$ /Caster $\pm 2.00^\circ$
Required: 1 per axle

APPLICATIONS

- Ford RWD/4WD:**
1995 - 01 Explorer
2001 - 05 Explorer Sport Trac
1998 - 11 Ranger
- Mazda RWD/4WD:**
1998 - 12 B-Series Pickup
- Mercury RWD/4WD:**
1996 - 01 Mountaineer



FORD EXPLORER CAMBER/CASTER KIT (4)

87500

Drive up to $\pm 2^\circ$ camber and caster change on the front of the Ranger, Explorer, Mountaineer, and B-Series Pickup by replacing the stock bolt and locking plate with this cam bolt kit from SPC. The 3/8" drive receiver on the cam allows for easy access from either side of upper control arm to make your changes. This kit includes 4 bolts, enough to do both sides. Need additional camber for your 2003 - 2011 Ranger 4WD? Check out the 26014 (pg 83) 1° camber shim to get change beyond what the 87500 gives you.



Front Adjustment range:
Camber $\pm 2.00^\circ$ /Caster $\pm 2.00^\circ$
Required: 1 per wheel

87515 APPLICATIONS

Nissan RWD/4WD: 1998 - 04 Frontier

87520 APPLICATIONS

- Infiniti RWD/4WD:** 2004 - 13 QX56; 2014 & Up QX80
Nissan RWD/4WD: 2004 & Up Armada, Titan
2005 & Up Frontier; 2005 - 15 Xterra; 2005 - 12 Pathfinder
Suzuki RWD/4WD: 2009 - 12 Equator



NISSAN CAMBER/CASTER KIT (PR)

87515
87520

These cams are designed to install in the upper or lower control arms for camber and caster adjustment. They replace the original non-adjustable lower control arm bolts.

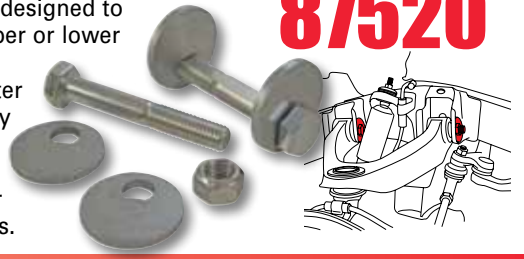

Front Adjustment range:
Camber $\pm 1.25^\circ$
Required: 1 per wheel

APPLICATIONS

- Ford:** 1989 - 97 Thunderbird
Lincoln: 1993 - 97 Mark VIII
Mercury: 1989 - 97 Cougar

T-BIRD, MARK VIII, COUGAR REPLACEMENT CAM KIT

87535

Use this stock replacement cam kit on the front lower arm to achieve $\pm 1.25^\circ$ front camber change on tenth generation Thunderbirds, Mark Vllls and Cougars. Kit provides easy and precise adjustment without any further modifications.



Parts

87540
87545

T-BIRD/LS FRONT CAM/CAS KIT (4)

These kits install in the lower control arms and provides easy and precise adjustment for caster and camber without any further modifications.



Front Adj. range: Camber $\pm 1.00^\circ$ /Caster $\pm 2.00^\circ$

Required: 1 per axle

87540 APPLICATIONS

Ford: 2002 - 06 Thunderbird

87545 APPLICATIONS

Jaguar: 2000 - 02 S-Type

Lincoln: 2000 - 06 LS

Replacement rear lower control arm joint kits are available for these vehicles - see page 153

88915
88920

TOYOTA FRONT OFFSET BEARING KIT

These offset bearing kits provide either $\pm 1^\circ$ or $\pm 3^\circ$ of camber and/or caster change for the non-adjustable Toyota Landcruiser 80 Series and Lexus LX450s with solid front axles. These vehicles are prone to caster loss when lifted, making the $\pm 3^\circ$ 88920 kit perfect for adding caster to restore "return to center" and improve tracking.

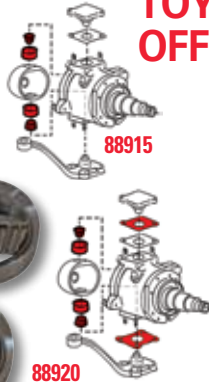

Front Adjustment range:

88915 Cam./Cas. $\pm 1.00^\circ$

88920 Caster Only $\pm 3.00^\circ$

NOTE: Only #88920 includes spacer plates.

Required: 1 per wheel

APPLICATIONS

Lexus:

1996 - 98 LX450

Toyota:

1991 - 97 Landcruiser 80 Series

88940

DANA 60 AXLE CAM/CAS KITS

These exclusive kits provide a camber and caster change for Dana 60 Axles. Replace the OE bushing with the correct eccentric bushing, rotate to adjust caster/camber and lock in place. These kits provide full adjustment for future alignments.

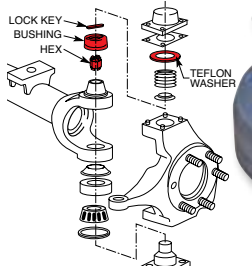

Front Adjustment range: Cam/Cas $\pm 1.00^\circ$

Required: 1 per wheel

MONOBEAM - DANA 60 APPS

Chevrolet/GMC: 1988 - 93 K30, V30, V3500

Dodge: 1972 - 83 W200/250
1975 - 93 W300/350

Ford: 1974 - 79 F250; 1974 - 91 F350

International: 1960 - 71 Pickup (1300)

89199 -
89899

UNI-WEDGE SHIMS (HD ZINC ALLOY)

Twice the coverage - half the inventory. Changes caster positive or negative from $1/2^\circ$ to 4° .

APPS: Any solid axle RWD or 4WD vehicle.

For more shims check out our complete Heavy Duty Truck Section on pages 141-149.

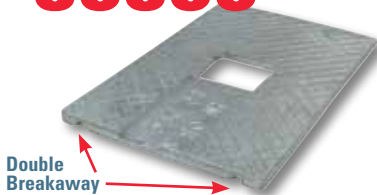

No.	Width	Degree Taper	Qty	No.	Width	Degree Taper	Qty
89199	3" - 3-1/2" - 4"	1/2°	6	89599	3" - 3-1/2" - 4"	2-1/2°	6
89299	3" - 3-1/2" - 4"	1°	6	89699	3" - 3-1/2" - 4"	3°	6
89399	3" - 3-1/2" - 4"	1-1/2°	6	89799	3" - 3-1/2" - 4"	3-1/2°	6
89499	3" - 3-1/2" - 4"	2°	6	89899	3" - 3-1/2" - 4"	4°	6

For additional shim widths see page 118

89635
89685

FORD CAMBER KIT (PR)

This kit provides front camber adjustment on many popular Ford vehicles. Camber adjustment of up to 1.25° . These plates are sold in pairs, one for each side of the vehicle.



Front Adjustment range: Camber 0° to $+1.25^\circ$

Required: 1 per axle

89635 APPLICATIONS

Ford: 1996 - 07 Taurus Sedan
1996 - 05 Taurus Wagon

Mercury: 1996 - 06 Sable Sedan; 1996 - 05 Sable Wagon

89685 APPLICATIONS

Ford: 2004 - 07 Freestar; 1994 - 03 Windstar

Mercury: 2004 - 07 Monterey



Front Adjustment range - fixed:
Camber -1.0°, 0°, +1.0°
Caster (built in) +3.0°

Required: 1 per wheel



APPLICATIONS

- Ford:** 1967 - 73 Mustang
1966 - 69 Fairlane
1966 - 69 Falcon
1970 - 77 Maverick
1966 - 71 Ranchero
1966 - 71 Torino
- Mercury:** 1966 - 77 Comet
1967 - 73 Cougar
1966 - 71 Cyclone

MUSTANG ADJUSTABLE ARM - 2ND GEN

94210

Modernize your early Ford and Mercury front suspension by installing adjustable upper control arms from SPC. SPC has built in 3° of caster to improve return to center with today's radial tires. The camber curve has been optimized by utilizing 'Shelby Drop' geometry in the billet aluminum cross shaft. The arm pivots are our maintenance-free **xAxis™ Sealed Flex Joints** for tight, responsive handling. Camber can be set to -1°, 0°, or +1° for superior cornering. Use this arm with either an OE style spring/shock or an aftermarket coilover kit. SPC's arm comes equipped with a stock style ball joint and all of the mounting hardware.



Replacement Ball Joint Available #94009 pg. 157

MUSTANG ADJ. ARM AND CASTER ROD - 1ST GEN

94215

Modernize your '64.5 to '66 Ford front suspension by installing an adjustable upper control arm and adjustable strut rod from SPC. SPC has built 3° of caster into the upper arm to improve return to center with today's radial tires.

Front Adjustment range:
Camber -1.0° to +1.75°*
Caster +1.00° to +5.00°*



Required: 1 per wheel

APPLICATIONS

- Ford:** 1964.5 - 66 Mustang
1964 - 65 Falcon
1964 - 65 Ranchero
- Mercury:** 1964 - 65 Comet
1964 - 65 Cyclone

*When combined with factory adjustment

Replacement Ball Joint Available #94009 - pg. 157

The adjustable strut rod features low durometer OE-style bushings to protect the chassis mount and allows for easy caster adjustment, similar to later Ford vehicles. The camber curve on the adjustable arm has been optimized by building 'Shelby Drop' geometry into the billet aluminum cross shaft. Camber can be adjusted by positioning the ball joint plate to 0°, -1°, or -2° and kit includes .25° and .50° shims for fine-tuning. Use this arm with either an OE style spring/shock or an aftermarket coilover kit. SPC's arm comes equipped with a stock style ball joint and all of the mounting hardware.

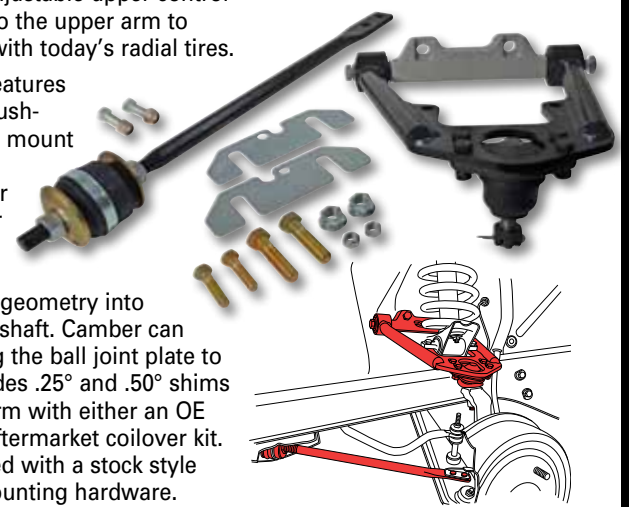

MUSTANG ADJUSTABLE CASTER ROD - 1ST GEN

94220

If you are running modern radial tires you should not follow factory alignment specifications for caster, SPC recommends 3° of caster to promote return to center steering. Stock strut rods on 1st generation Mustangs are non-adjustable and often have worn bushings that can cause unwanted movement of the lower rod assembly and poor handling. A must for early Mustangs, SPC's adjustable caster rod features low durometer OE-style bushings to protect the chassis mount from damage and has easy caster adjustment. This adjustable strut rod will provide the positive caster needed for improved tracking and modern geometry. If you want additional caster or want to adjust camber, check out SPC control arm kit #94215 (above).

Front Adjustment range:
Caster ±2.00°

Installation time: .5 hr/side

Required: 1 per wheel

APPLICATIONS

- Ford:** 1964.5 - 66 Mustang
1964 - 65 Falcon
1964 - 65 Ranchero
- Mercury:** 1964 - 65 Comet
1964 - 65 Cyclone



Featured Owner: David Cox

David Cox restores classic Mustangs and provided our test platform for our 94215 adjustable front arm and caster rod. Dave's feedback on the new set-up was great, "The handling on these older cars is really lacking, but SPC's arms improved tracking, added additional adjustability and are well built."

Parts

GM Muscle Car Tubular Lower Arms

Coilover Mounts augment coil stability on all of SPC's tubular lower arms - see next page

94344

GM 'A' BODY

These arms lower your front end by 1" and add 1° positive caster for a ready-to-run, aggressive stance. Optional Ride Height Tuning Kits are available for use with our Pro Series Springs or 'standard type' springs to raise the ride height if desired. If you have coilovers use our Coilover Mount and Spacer Plate. Check out the optional OE style bump stop (#95339 next page). **Sold as pairs.**



94016 - Premium Upgrade Extended Length Ball Joint - see page 157

94344 GM 'A' BODY

Front Fixed Change: Caster +1.00°

Required: 1 per axle

Pro Springs #94391/94392 (pg. 137)

Coilover Mount/Spacer Kit #94346/94348 (pg. 137)

APPLICATIONS

Buick: 1964 - 72 GS, Skylark, Special
Chevrolet: 1964 - 72 Chevelle, El Camino, Malibu
1970 - 72 Monte Carlo
Oldsmobile: 1964 - 72 442, Cutlass
Pontiac: 1964 - 72 GTO, LeMans
1964 - 70 Tempest



94374

GM 1ST GEN. 'F'

These tubular arms are a perfect fit for 1st Gen 'F' Bodies and will lower your front end by 1" as well as add 1° positive caster for an aggressive, ready-to-run stance. Ride Height spacer and Coilover Mounts are available. To complete your arm add an OE style bump stop (#95339 next page). **Sold as pairs.**



94374 GM 1ST GEN 'F' BODY

Front Fixed Change: Caster +1.00°

Required: 1 per axle

Pro Springs #94393 (pg. 137)

Coilover Mount/Spacer Kit #94346/94348 (pg. 137)

APPLICATIONS

Buick: 1973 - 74 Apollo
Chevrolet: 1967 - 69 Camaro
1968 - 74 Nova
Pontiac: 1967 - 69 Firebird



94378

GM 2ND GEN. 'F', AND 'B'

Our 2nd Gen 'F' lower arms feature a rugged formed plate body. To achieve an aggressive, ready-to-run stance, these arms will add 2.5° positive caster and may be configured for stock or lowered height. Ride Height spacer and Coilover Mounts are available. **Note: Shown with an optional OE style bump stop (#95339 next page). Sold as pairs.**



94374 GM 2ND GEN 'F' BODY

Front Fixed Change: Caster +2.50°

Required: 1 per axle

Pro Springs #94394 (pg. 137)

Coilover Mount/Spacer Kit #95332/95338 (pg. 137)

APPLICATIONS

Buick: 1971 - 85 LeSabre;
1973 - 77 Century, Regal; 1975 - 79 Skylark
Chevrolet: 1970 - 81 Camaro; 1971 - 96 Caprice
1973 - 77 Chevelle; 1973 - 77 El Camino, Malibu,
Monte Carlo; 1971 - 96 Impala; 1975 - 79 Nova
Oldsmobile: 1973 - 77 Cutlass; 1975 - 79 Omega
1971 - 85 88
Pontiac: 1971 - 81 Bonneville; 1970 - 81 Firebird
1973 - 75 Grand Am; 1973 - 77 Grand Prix, LeMans



95336

GM 'G' BODY

Improve your handling and tracking with these new tubular arms and lower your front end by 1" and add 1° positive caster for an aggressive, ready-to-run stance. Optional Coilover Mount/Spacer Kits are available for use with our Pro Series Springs or 'standard type' springs to raise the ride height if desired (#95332/ 95338). To complete your arm you can also add an OE style bump stop (#95339 next page). **Sold as pairs.**



95336 GM 'G' BODY

Front Fixed Change: Caster +1.00°

Required: 1 per axle

Pro Springs #94390 (pg. 137)

Coilover Mount/Spacer Kit #95332/95338 (pg. 137)

APPLICATIONS

Buick: 1978 - 87 Grand National, Regal
Chevrolet: 1978 - 88 El Camino; 1978 - 83 Malibu
1978 - 88 Monte Carlo
1982 - 04 Blazer S Series, Jimmy S Series,
S10/S15 Pickup/Sonoma (RWD)
Oldsmobile: 1978 - 88 Cutlass
Pontiac: 1982 - 86 Bonneville; 1978 - 80 Grand Am
1978 - 87 Grand Prix; 1978 - 81 LeMans



94018 - Premium Upgrade Extended Length Ball Joint - see page 157

APPLICATIONS

'A' Bodies &
1st Gen. 'F' Bodies

94348 2 Spacers
94346 4 Spacers

2nd Gen. 'F' Bodies, 'B'
Bodies & 'G' Bodies

95338 2 Spacers
95332 4 Spacers

COILOVER MOUNT/SPACER PLATES

These Flat Coil Spring Mount/Spacer Plates are designed to maximize your ride height options. Use these plates as coilover mounts to augment coil stability on SPC's tubular lower arms. If you need to fine-tune your ride height these plates can also be stacked to change height. Use one spacer per side to add 1/2" or add two spacers per side to gain about 1" in ride height.

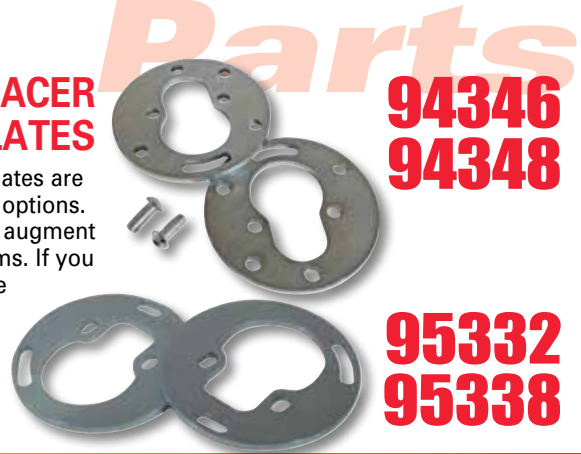

GM Muscle Car Pro Springs

SPC Performance Pro Spring Kit offers immediate handling enhancement and gives your muscle car an aggressive stance! Front springs provide approximately a **1.3" drop*** and rear springs **1.0" drop***. Highest quality and design assures springs will retain optimum rates for unsurpassed performance. Springs are epoxy coated with a diamond black color and have a lifetime warranty. Sold as a complete vehicle package. If you are using these springs with our lower arms, and need to fine tune your ride height use our Height Spacers (above).

Make	Model (Springs rated for small block only)	Spring Rate	Pro Springs	Ride Height Spacers
'A' Body - Set of 4 Springs - Front and Rear				
Buick	GS, Skylark, Special (64-67)	550/165	94391	94332/95338
Buick	GS, Skylark, Special (68-72)	550/112-188	94392	94332/95338
Chevrolet	Chevelle, El Camino, Malibu (64-67)	550/165	94391	94332/95338
Chevrolet	Chevelle, El Camino, Malibu, Monte Carlo (68-72)	550/112-188	94392	94332/95338
Oldsmobile	442, Cutlass, Cutlass Supreme (64-67)	550/165	94391	94332/95338
Oldsmobile	442, Cutlass, Cutlass Supreme (68-72)	550/112-188	94392	94332/95338
Pontiac	GTO, LeMans, Tempest (64-67)	550/165	94391	94332/95338
Pontiac	GTO, LeMans, Tempest (68-72)	550/112-188	94392	94332/95338
'F' Body - Set of 2 Springs - Front Only				
Buick	Apollo (73-74)	500	94393	94332/95338
Chevrolet	Camaro (67-69); Nova (68-74)	500	94393	94332/95338
Pontiac	Firebird (67- 69)	500	94393	94332/95338
Chevrolet	Camaro (70-81)	577	94394	94346/95348
Pontiac	Firebird (70-81)	577	94394	94346/95348
'G' Body - Set of 4 Springs - Front and Rear				
Buick	Grand National, Regal (78-87)	675/114-188	94390	94346/95348
Chevrolet	El Camino, Malibu, Monte Carlo (78-88)	675/114-188	94390	94346/95348
Oldsmobile	Cutlass, Cutlass Supreme (78-88)	675/114-188	94390	94346/95348
Pontiac	Bonneville (83-86); Grand Am (78-80) Grand Prix (78-88); LeMans (78-81)	675/114-188	94390	94346/95348

94390
94391
94392
94393
94394

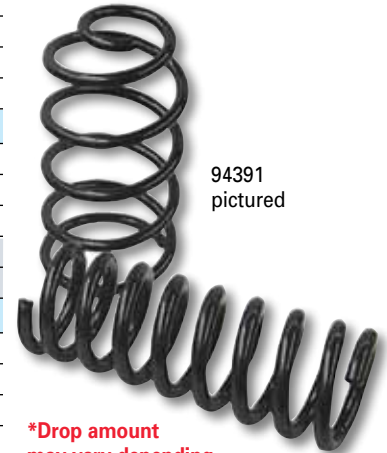

*Drop amount may vary depending on vehicle weight, options, etc.)

GM REPLACEMENT BUMP STOP

OE cone style to replace worn bump stops.



95339



Get the look Enjoy the ride

Transform your American Muscle with SPC suspension components. With adjustable front upper control arms (page 138), tubular lower arms (previous page) and Pro Springs (above) you can get the stance you want while enjoying Pro Touring handling and ride.

Parts

GM Muscle Car Adjustable Upper Control Arms

This patented design will give you the most adjustability and best clearance of any arm on the market. Sold as a pair, these adjustable arms come with ball studs that are 1/2" taller than stock to improve camber curve. Throw in some caster and the ability to tune camber and you will have a 'modern' feeling suspension. The ball joints are grease-able and rebuildable. Additionally, OE length and 1/4" extended studs are available to tune your ride or maximize your specific suspension geometry. Consider combining these with SPC's lower control arms (page 136) and 1" lowering springs (page 137) to complete the transformation of your Pro Touring, Track Ready, or daily driving street use American Muscle. **Sold as pairs.**

'A' BODY

97110 Pair

Greaseable Performance Bushings Avail. #92025 pg 156

Stud Taper 7.12°



US Patent No. 9,751,370

Lower Arms page 137, Pro Springs page 136

Front Adj. range: Camber ±3.00° Caster ±3.00°

Required: 1 per axle

APPLICATIONS

Buick: 1964 - 72 GS, Skylark, Special
Chevrolet: 1964 - 72 Chevelle, El Camino, Malibu
 1970 - 72 Monte Carlo
Oldsmobile: 1964 - 72 442, Cutlass
Pontiac: 1964 - 72 GTO, LeMans; 1964 - 70 Tempest

1ST GEN. 'F' BODY

97120 Pair

Greaseable Performance Bushings Avail. #92025 pg 156

Stud Taper 7.12°



US Patent No. 9,751,370

Lower Arms page 137, Pro Springs page 136

Front Adj. range: Camber ±3.00° Caster ±3.00°

Required: 1 per axle

APPLICATIONS

Buick: 1973 - 74 Apollo
Chevrolet: 1967 - 69 Camaro; 1968 - 74 Nova
Pontiac: 1967 - 69 Firebird

2ND GEN. 'F' BODY 'B' BODY

97130 Pair

Greaseable Performance Bushings Avail. #92025 pg 156

Stud Taper 9.5°



US Patent No. 9,751,370

Lower Arms page 137, Pro Springs page 136

Front Adj. range: Camber ±3.00° Caster ±3.00°

Required: 1 per axle

APPLICATIONS

Buick: 1971 - 85 LeSabre; 1973 - 77 Century, Regal
 1975 - 79 Skylark
Chevrolet: 1970 - 81 Camaro; 1973 - 96 Caprice
 1973 - 77 Chevelle; 1973 - 77 El Camino, Malibu,
 Monte Carlo; 1973 - 96 Impala; 1975 - 79 Nova
Oldsmobile: 1973 - 77 Cutlass; 1975 - 79 Omega,
 1971 - 85 88
Pontiac: 1971 - 76 Bonneville; 1970 - 81 Firebird
 1973 - 75 Grand Am; 1973 - 77 Grand Prix, LeMans

'G' BODY

97140 Pair

Greaseable Performance Bushings Avail. #92025 pg 156

Stud Taper 9.5°



US Patent No. 9,751,370

Lower Arms page 137, Pro Springs page 136

Front Adj. range: Camber ±3.00° Caster ±3.00°

Required: 1 per axle

APPLICATIONS

Buick: 1978 - 87 Grand National, Regal
Chevrolet: 1978 - 88 El Camino; 1978 - 83 Malibu
 1978 - 88 Monte Carlo
 1982 - 04 Blazer S Series, Jimmy S Series,
 S10/S15 Pickup/Sonoma (RWD)
Oldsmobile: 1978 - 88 Cutlass
Pontiac: 1982 - 86 Bonneville; 1978 - 80 Grand Am
 1978 - 87 Grand Prix; 1978 - 81 LeMans

Ball Joint Rebuild Kits

With SPC's rebuild kit you can replace the ball joint or customize the stud length for ride height altered vehicles. Includes: ball joint boot, ball stud, ball joint race, washer, wave spring, castle nut, cotter pin.

 **72120 - Spanner Wrench, pg 169**

Ball Joint #	Taper	Stud Length	Fits Part #	Ball Joint #	Taper	Stud Length	Fits Part #
97001	7.12°	OE length		97004	9.5°	OE length	
97002	7.12°	+0.25" stud	97110, 97120	97005	9.5°	+0.25" stud	97130, 97140
97003	7.12°	+0.50" stud	97150, 97170	97006	9.5°	+0.50" stud	



Applications

Alignment Parts

Heavy Duty

OE Replacement

Racing/Builders

Tools

Brake and CV

Gear/Index

Bring modern handling and adjustability to your classic GM Muscle Car. By replacing your front upper and lower control arms and adding high performance springs you can once again enjoy driving your muscle car.

'A' BODY

Buick: GS, Skylark Special
Chevrolet: Chevelle, El Camino, Malibu, Monte Carlo
Oldsmobile: 442, Cutlass
Pontiac: GTO, LeMans, Tempest

ADJUSTABLE UPPER CONTROL ARMS

This patented design will give you the most adjustability and best clearance of any arm on the market. Sold as a pair, these adjustable arms come with ball studs that are 1/2" taller than stock to improve camber curve. Throw in some caster and the ability to tune camber and you will have a 'modern' feeling suspension. The ball joints are grease-able and rebuildable. *Sold as pairs see previous page.*

97110 Pair



TUBULAR LOWER ARMS

These arms lower your front end by 1" and add 1" positive caster for a ready-to-run, aggressive stance. Optional Ride Height Tuning Kits are available for use with our Pro Springs or 'standard type' springs to raise the ride height if desired. If you have coilovers use our Coilover Mount and Spacer Plate. Includes stock lower ball joint. *Sold as pairs see pages 136.*

94344 Pair



Coilover Mount/
Spacer Kit #94346/94348

Premium Upgrade Extended
Length Ball Joint #94016

PRO SPRINGS

SPC Performance Pro Spring Kit offers immediate handling enhancement and gives your muscle car an aggressive stance! Front springs provide approximately a 1.3" drop* and rear springs 1.0" drop*. Highest quality and design assures optimum return rates. *Sold as package see page 137.*

Set of 4 Springs Front and Rear

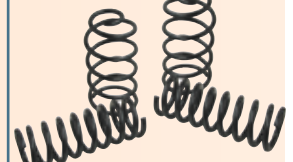

94391 '64-'67 A Body
94392 '68-'75 A Body

1ST GEN. 'F' BODY

Buick: Apollo
Chevrolet: Camaro, Nova
Pontiac: Firebird



97120 Pair



94374 Pair



Coilover Mount/
Spacer Kit #94346/94348

Set of 2 Springs Front only



94393 1st Gen.
F Body

2ND GEN. 'F' BODY

Buick: Century, LeSabre, Regal, Skylark
Chevrolet: Camaro, Caprice, Chevelle, El Camino, Impala, Malibu, Monte Carlo, Nova
Oldsmobile: C88, Cutlass, Omega
Pontiac: Bonneville, Firebird, Grand Am, Grand Prix, LeMans

97130 Pair



94378 Pair



Coilover Mount/
Spacer Kit #95338/95332

Set of 2 Springs Front only



94394
2nd Gen. F
Body



'G' BODY

Buick: Grand National, Regal
Chevrolet: Blazer & Jimmy S, El Camino, Malibu, Monte Carlo, Pickup/Sonoma, S10/S15 (RWD)
Oldsmobile: Cutlass
Pontiac: Bonneville, Grand Am, Grand Prix, LeMans

97140 Pair



95336 Pair



Coilover Mount/Spacer Kit
#95338/95332

Premium Upgrade Extended
Length Ball Joint #94018

Set of 4 Springs Front and Rear

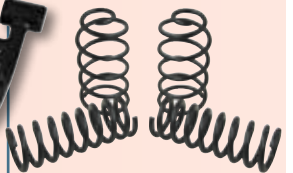

94390 G Body



Parts

Applications

Alignment Parts

97150
97160
97170
97180
97190

GM ADJUSTABLE UPPER CONTROL ARMS (PR)

Use this patented design with the most adjustability and best clearance of any arm on the market to modernize the front suspension on your classic Chevy. SPC uses a ½" extended ball stud to improve camber curve, now adjust in some caster and a bit of camber and enjoy the drive. The fully rebuildable and greasable ball joints can also be

customized for your ride with available OE length and ¼" extended studs. **Sold as pairs.**



NEW



Front Adjustment range:
Camber ±3.00° Caster ±3.00°
Required: 1 per axle

97150 APPLICATIONS

Chevrolet: 1958 - 64 Bel Air, Biscayne, Caprice, Impala
1958 - 63 El Camino

97160 APPLICATIONS

Chevrolet: 1963 - 82 Corvette C2/C3

97170 APPLICATIONS

Chevrolet: 1955 - 57 Tri-5 (shown in photo)

97180 APPLICATIONS

Chevrolet: 1973 - 87 C10 Pickups
1973 - 91 Blazer; 1973 - 91 Suburban

97190 APPLICATIONS

Chevrolet: 1984 - 96 Corvette C4

Stud Taper 7.12° - To replace or customize your ball joint see page 138

Greaseable Performance Bushings Avail. #92025 pg 156

US Patent No. 9,751,370

OE Replacement

Pricing/Builders

Tools

Brake and CV

97260

MUSTANG II ADJUSTABLE UPPER CONTROL ARMS - COIL OVER CONVERSIONS

Use this patented design with the most adjustability and best clearance of any arm on the market to modernize the front suspension on your Mustang II custom build. SPC uses a ½" extended ball stud to improve camber curve, now adjust in some caster and a bit of camber and enjoy the drive. The fully rebuildable and greasable ball joints can also be customized for your ride with available OE length and ¼" extended studs. **Sold as pairs.**



NEW



Front Adjustment range:
Camber ±3.00° Caster ±3.00°
Required: 1 per axle

APPLICATIONS

Ford: 1974 - 78 Mustang II

NOTE: For Coil Over Conversions ONLY

Greaseable Performance Bushings Available #92025 pg 156

Stud Taper 7.12° To replace or customize your ball joint see page 138

US Patent No. 9,751,370

97300

MOPAR 'A', 'B', & 'E' BODY ADJUSTABLE CONTROL ARMS (PR)

Use this patented design with the most adjustability and best clearance of any arm on the market to modernize the front suspension on your classic Mopar. SPC uses a ½" extended ball stud to improve camber curve, now adjust in some caster and a bit of camber and enjoy the drive. The fully rebuildable and greasable ball joints can also be customized for your ride with available OE length and ¼" extended studs. **Sold as pairs.**



NEW



Front Adjustment range:
Camber ±3.00° Caster ±3.00°
Required: 1 per wheel

'B' & 'E' APPLICATIONS

Dodge: 1962 - 65 All Passenger (except 880)
1970 - 74 Challenger
1966 - 72 Charger
1965 - 72 Coronet (Incl. Super Bee)

Plymouth: 1962 - 64 All Passenger
1970 - 74 Barracuda
1965 - 70 Belvedere
1967 - 71 GTX
1968 - 72 Road Runner
1965 - 72 Satellite

'A' APPLICATIONS

Dodge: 1973 - 76 Dart
Plymouth: 1973 - 75 Valiant

US Patent No. 9,751,370

Stud Taper 7.12° - To replace or customize your ball joint see page 138



36000 Tandem Alignment Set

A great starter set!

These alignment angle shims are available in a heavy-duty metal box to help you organize all of your shims. Packaged with a large variety of shims (listed below and on pages 142 and 144) and an organization chart inside the lid to make reordering and organization of shims quick and easy. Don't be caught without the shim you need while you have the tractor in your shop!



Part No.	Application	Qty	Part No.	Application	Qty
35001	Kenworth Airglide space 1/32"	6	35040	Navistar IHC Torque Arm 1/32"	6
35002	Kenworth Airglide space 1/16"	6	35041	Navistar IHC Torque Arm 1/16"	6
35003	Kenworth Airglide space 1/8"	6	35042	Navistar IHC Torque Arm 1/8"	6
35004	Kenworth Airglide space 1/4"	6	35060	Freightliner Airliner Susp 1/32"	6
35005	Kenworth Airglide space 1/2"	6	35061	Freightliner Airliner Susp 1/16"	6
35006	Kenworth Airglide space 3/4"	6	35062	Freightliner Airliner Susp 1/8"	6
35007	Kenworth Airglide space 1"	6	36020	Navistar Corp. 6x4 Air Susp. 1/32"	6
35010	Peterbilt Air Leaf Shim 1/32"	6	36021	Navistar Corp. 6x4 Air Susp. 1/16"	6
35011	Peterbilt Air Leaf Shim 1/16"	6	36022	Navistar Corp. 6x4 Air Susp. 1/32"	6
35012	Peterbilt Air Leaf Shim 1/8"	6	36087	Hendrickson Rear Tandem Walking Beam	10

Tandem Truck Shims

These over-the-road heavy duty adjusters are a fast and accurate means to align front or rear axles of most popular tandem trailers and trucks. You, the alignment technician, now have reliable means to complete total heavy duty truck alignments.

KENWORTH AIR GLIDE SPACERS FOR "EIGHT BAGGERS"

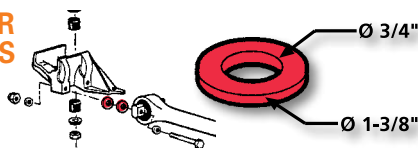

Part No.	Thickness	Qty	Part No.	Thickness	Qty
35001	1/32"	6	35005	1/2"	6
35002	1/16"	6	35006	3/4"	6
35003	1/8"	6	35007	1"	6
35004	1/4"	6			

FREIGHTLINER ADJUSTING SHIM

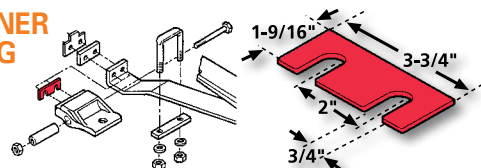

These shims adjust thrust angle and toe by placing it between the spring hanger and the spring.

Part No.	Thickness	Qty
35020	1/32"	6
35021	1/16"	6
35022	1/8"	6

PETERBILT AIR LEAF THRUST ANGLE SHIM

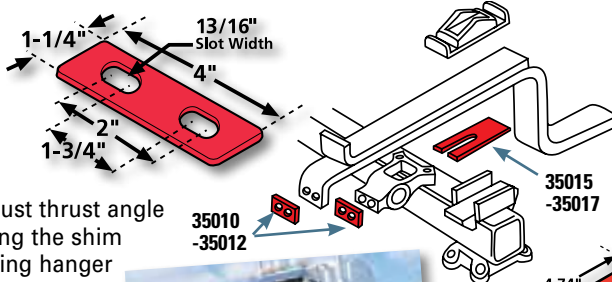

These shims adjust thrust angle and toe by placing the shim between the spring hanger and the spring.

Part No.	Thickness	Qty
35010	1/32"	6
35011	1/16"	6
35012	1/8"	6

PETERBILT AIR LEAF PINION ANGLE SHIM

Adjust pinion angle on the drive axle of your Peterbilt Low Air Leaf with 'Z-Springs' using these shims. The OE shim is aluminum and does not last under load; the SPC Zinc Shim is built to last.

Part No.	Angle Change	Qty
35015	1.0°	2
35016	1.5°	2
35017	2.0°	2

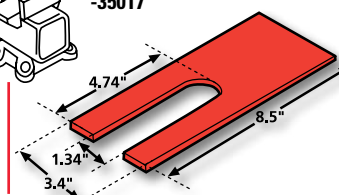

We have parts and tools for Fleet Vehicles - check out our application charts (pages 7 - 70).

Heavy Duty Tandem Truck Shims

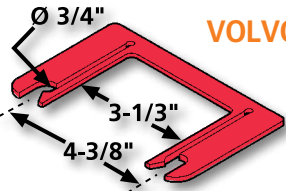

VOLVO/WHITE TANDEM SHIM

Part No.	Thickness	Qty
35030	1/32"	6
35031	1/16"	6
35032	1/8"	6

These shims adjust thrust angle and toe by placing it between the spring hanger and the spring.

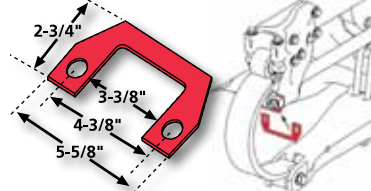

PETERBILT/ KENWORTH FLEX AIR SUSPENSION SHIMS

Part No.	Thickness	Qty
36010	1/32"	6
36011	1/16"	6
36012	1/8"	6

By shimming the torque arms these shims adjust toe and thrust angle.

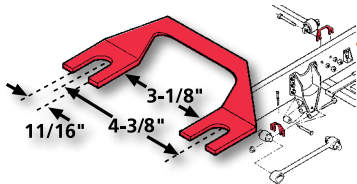

I.H.C./NAVISTAR TORQUE ARM SHIM

Part No.	Thickness	Qty
35040	1/32"	6
35041	1/16"	6
35042	1/8"	6

Will change thrust and toe when installed between the torque arm and the spring hanger. On Navistar they will also center the axle with the frame rails when used on the lateral link.

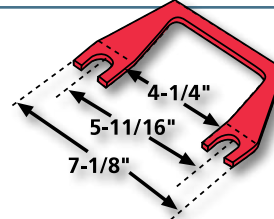

NAVISTAR SHIM FOR "CORPORATE" 6x4 AIR SUSPENSION

Part No.	Thickness	Qty
36020	1/32"	6
36021	1/16"	6
36022	1/8"	6

When used on the lateral link these shims will center the axle with the frame rails. Also will adjust thrust angle and toe by placing the shim between the spring hanger and the spring.

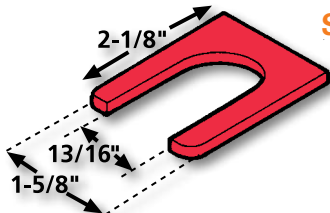

SINGLE SLOT TANDEM TEMSA TRUCK SHIMS

USE ON TEMSA BUS
UPPER CONTROL ARM
FOR CAMBER/CASTER

Part No.	Thickness	Qty
35060	1/32"	6
35061	1/16"	6
35062	1/8"	6

USE FOR FREIGHTLINER
"AIRLINER" K77936 SUSPENSION

Part No.	Thickness	Qty
35063	1/32"	100
35064	1/16"	100
35065	1/8"	100

These universal shims are installed at the ends of torque rods to change toe and/or thrust angles on **Freightliner**, **Hendrickson** and **Navistar** heavy duty tandem trucks and trailers. Also adjusts camber and/or caster on **Temsa Bus** front upper control arms.

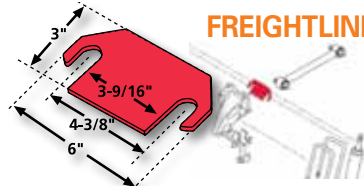

FREIGHTLINER SHIMS FOR FAS II SUSPENSIONS

Part No.	Thickness	Qty
36031	1/16"	6
36032	1/8"	6

Will change thrust and toe when installed between the torque arm and the spring hanger. They will also center the axle with the frame rails when used on the lateral link.



NOW
AVAILABLE IN
100 PACKS!

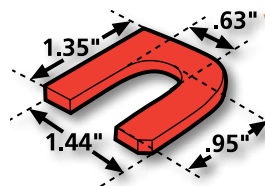

VANHOOL LOWER CONTROL ARM & BOGEY AXLE SHIM

Part No.	Thickness	Qty
36040	1/32"	6
36041	1/16"	6
36042	1/8"	6

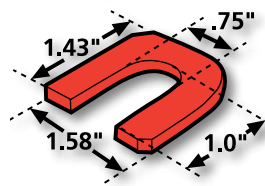

VANHOOL UPPER CONTROL ARM & DRIVE AXLE SHIM

Part No.	Thickness	Qty
36050	1/32"	6
36051	1/16"	6
36052	1/8"	6

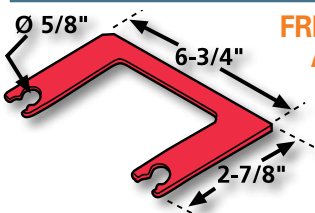

FREIGHTLINER SHIMS FOR AIR GLIDE SUSPENSION

Part No.	Thickness	Qty
35070	1/32"	6
35071	1/16"	6
35072	1/8"	6

These shims adjust thrust angle and toe by placing the shim between the spring hanger and the spring.

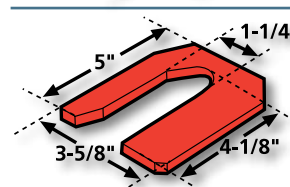

PREVOST CASTER SHIM

Part No.	Thickness	Qty
36060	1/32"	6
36061	1/16"	6
36062	1/8"	6

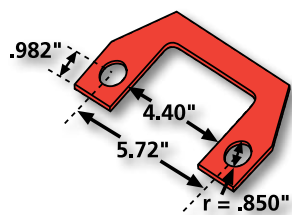

PETERBILT/KENWORTH THRUST ANGLE SHIMS

Part No.	Thickness	Qty
36001	1/32"	6
36002	1/16"	6
36003	1/8"	6

These shims are for the new Peterbilt and Kenworth "Low Air Suspensions".

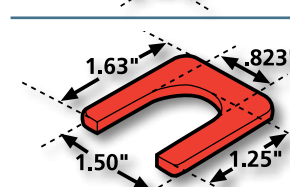

PREVOST CASTER SHIM

Part No.	Thickness	Qty
36070	1/32"	6
36071	1/16"	6
36072	1/8"	6

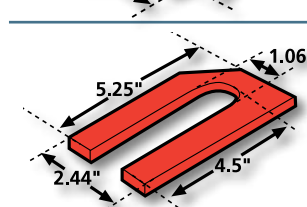

PREVOST X & XL SHIM

Part No.	Thickness	Qty
36090	1/32"	6
36091	1/16"	6
36092	1/8"	6

LOOKING FOR HENDRICKSON SHIMS?

See page 144.



Heavy Duty Truck Axle Shims

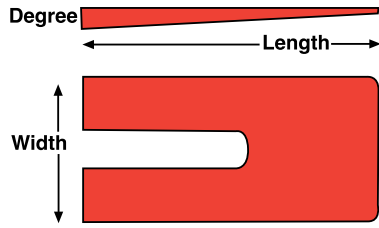

	COST	COMPRESSION STRENGTH	HARDNESS
ALUMINUM ALLOY	\$\$	★★★	★★★
ZINC ALLOY	\$\$\$	★★★★★	★★★★★
MANGANESE BRONZE ALLOY	\$\$\$\$\$	★★★★★	★★★★★

Ordering one Part Number supplies **SIX SHIMS** in a box. When placing order spring pad length and width is needed.

Choose from Aluminum, ZINC and Manganese Bronze Shims

ALUMINUM ALLOY	ZINC ALLOY	MANGANESE BRONZE	SPRING WIDTH	DEGREE	SPR. PAD LENGTH	QTY/BOX
10405	10403	10404	2-1/2"	1/2°	5"	6
10412	10413	10414	2-1/2"	1°	5"	6
10422	10423	10424	2-1/2"	1-1/2°	5"	6
10432	10433	10434	2-1/2"	2°	5"	6
10442	10443	10444	2-1/2"	2-1/2°	5"	6
10452	10453	10454	2-1/2"	3°	5"	6
10462	10463	10464	2-1/2"	3-1/2°	5"	6
10472	10473	10474	2-1/2"	4°	5"	6
10505	10503	10504	3"	1/2°	6"	6
10512	10513	10514	3"	1°	6"	6
10522	10523	10524	3"	1-1/2°	6"	6
10532	10533	10534	3"	2°	6"	6
10542	10543	10544	3"	2-1/2°	6"	6
10552	10553	10554	3"	3°	6"	6
10562	10563	10564	3"	3-1/2°	6"	6
10572	10573	10574	3"	4°	6"	6
10605	10603	10604	3-1/2"	1/2°	6-1/4"	6
10612	10613	10614	3-1/2"	1°	6-1/4"	6
10622	10623	10624	3-1/2"	1-1/2°	6-1/4"	6
10632	10633	10634	3-1/2"	2°	6-1/4"	6
10642	10643	10644	3-1/2"	2-1/2°	6-1/4"	6
10652	10653	10654	3-1/2"	3°	6-1/4"	6
10662	10663	10664	3-1/2"	3-1/2°	6-1/4"	6
10672	10673	10674	3-1/2"	4°	6-1/4"	6
10705	10703	10704	4"	1/2°	6-1/2"	6
10712	10713	10714	4"	1°	6-1/2"	6
10722	10723	10724	4"	1-1/2°	6-1/2"	6
10732	10733	10734	4"	2°	6-1/2"	6
10742	10743	10744	4"	2-1/2°	6-1/2"	6
10752	10753	10754	4"	3°	6-1/2"	6
10762	10763	10764	4"	3-1/2°	6-1/2"	6
10772	10773	10774	4"	4°	6-1/2"	6
10782	10783	--	4"	5°	6-1/2"	6

Specialty Products carries Truck Axle Caster Shims in three different alloys, giving the technician the opportunity to match price point and mechanical requirements to meet their customer's needs. **Note: Shims should not be stacked.**

ALUMINUM ALLOY HD SHIMS

These economical over-the-road heavy duty truck axle shims are our lowest cost option. With average compression strength and hardness these shims are available in a large variety of sizes and offer the technician a cost effective means to correct caster on over-the-road trucks and trailers.



ZINC ALLOY HD SHIMS

These over-the-road heavy duty truck axle shims are a fast and accurate means to align front or rear axles of most popular tandem trailers and trucks. Specialty Products' new Zinc Alloy shims offer another level of performance versus our traditional aluminum shims. For a small cost increase versus aluminum, you now have the hardness of our premium manganese bronze shims and a much improved compression strength as compared to aluminum shims.



MANGANESE BRONZE HD SHIMS

These shims are the standard. Top of the line compression strength and hardness means that when you set your alignment - it doesn't change.



NOTE - if you are using "Z Blocks" or other axle spacers you need to spread the load to prevent the shim from crushing. Check out SPC's HD Axle Spacer Plate below to solve this common problem.

HD AXLE SPACER PLATE (6)

Spread the load! "Z" Blocks and other axle spacers used by Hendrickson, Freightliner, Kenworth, Mack, Hollis, Sterling, Ford, and others create pressure points that will crush or even break the toughest of caster wedges. Use this HD Wedge Spacer Plate to spread the load and then use the caster shim of your choice to modify alignment. The 1/8" thick plates come 6 to a pack and are available in three widths. The HD Wedge Spacer Plate can also be used to dial in ride height from side to side.

#10598 - 3" Wide • #10698 - 3.5" Wide
#10798 - 4" Wide

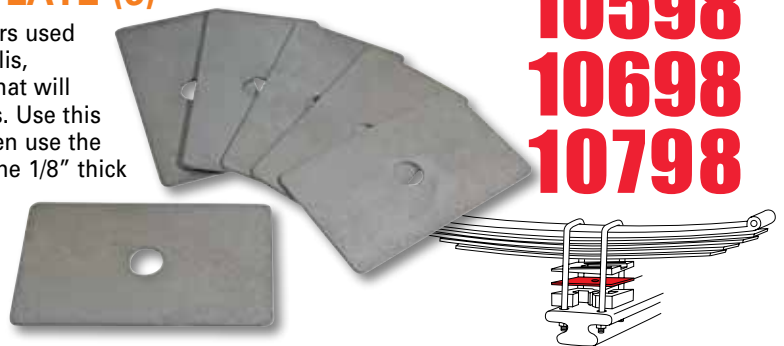

10598
10698
10798

Heavy Duty Truck Axle Shims

80199-81099

ZINC TRUCK AXLE SHIMS

These popular heavy-duty axle shims are for vehicles with 1-3/4" to 2" wide leaf springs. **APPLICATIONS:** Any solid axle 2WD or 4WD vehicle.

Note: Shims should not be stacked.

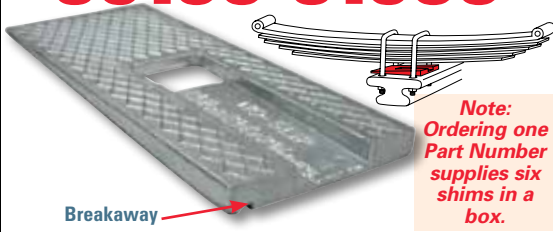

Note: Ordering one Part Number supplies six shims in a box.

Part No.	Width	Degree Taper	Qty/Box	Part No.	Width	Degree Taper	Qty/Box
80199	1-3/4" - 2"	1/2°	6	80699	1-3/4" - 2"	3°	6
80299	1-3/4" - 2"	1°	6	80799	1-3/4" - 2"	3-1/2°	6
80399	1-3/4" - 2"	1-1/2°	6	80899	1-3/4" - 2"	4°	6
80499	1-3/4" - 2"	2°	6	80999	1-3/4" - 2"	5°	6
80599	1-3/4" - 2"	2-1/2°	6	81099	1-3/4" - 2"	6°	6

89199-89899

UNI-WEDGE SHIMS (HD ZINC ALLOY)

Twice the coverage - half the inventory. Changes caster positive or negative from 1/2° to 4°. **APPLICATIONS:** Any solid axle 2WD or 4WD vehicle.

Note: Shims should not be stacked.

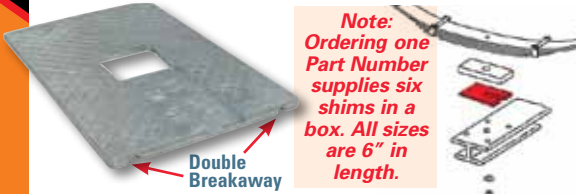

Note: Ordering one Part Number supplies six shims in a box. All sizes are 6" in length.

Part No.	Width	Degree Taper	Qty/Box	Part No.	Width	Degree Taper	Qty/Box
89199	3" - 3-1/2" - 4"	1/2°	6	89599	3" - 3-1/2" - 4"	2-1/2°	6
89299	3" - 3-1/2" - 4"	1°	6	89699	3" - 3-1/2" - 4"	3°	6
89399	3" - 3-1/2" - 4"	1-1/2°	6	89799	3" - 3-1/2" - 4"	3-1/2°	6
89499	3" - 3-1/2" - 4"	2°	6	89899	3" - 3-1/2" - 4"	4°	6

35035 35036 35037

HENDRICKSON (HTB) TORQUE ARM SHIMS (6)

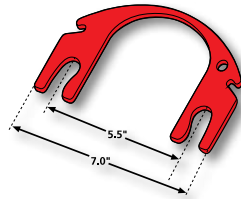

Adjust the Hendrickson (HTB) Torque Arm with these replacement shims. Shims are available in a variety of thicknesses to meet your needs. Sold in boxes of 6 Shims. Adjust torque box with the 35038 shim set (below).

Part No.	Thickness	Qty
35035	1/32"	6
35036	1/16"	6
35037	1/8"	6

35035, 35036, 35037
Adjustment: Torque Arm

35038

Adjustment: Torque Box

APPLICATIONS

Hendrickson HTB: 2007 & Up
International: 2007 & Up
Spartan: 2007 & Up

35038

HENDRICKSON (HTB) TORQUE BOX ADJUSTMENT SET (10)



Adjust the Hendrickson HTB torque box with this full set of 10 replacement shims. The shim set includes 4 of the 1/32" shims, 4 of the 1/16" shims, and also 2 of the 1/8" shims to give you a full range of adjustment. Need to adjust the torque arm as well? Try our 35035, 35036, or 35037 shims (above).

36080 36085

36080



36085

HENDRICKSON WALKING BEAM SHIMS

These are the OE style shims recommended by Hendrickson. The 36080 offers three adjustments at 0, 3/16" and 3/8". The 36085 gives you four different adjustments of 0, 1/8", 1/4" and 3/8". Each part number includes 2 to a package.

36087

HENDRICKSON HD SHIMS

This shim kit will adjust the thrust angle on Hendrickson's 'walking beam' rear tandem axle suspension. Improve tire wear and handling by adjusting thrust angle from 0" to 3/8" in precise 1/32" increments.

REPLACES these OE kits-

Euclid Nos: E-9327, E-9328, E-9329

Hendrickson Nos: 50130-000, 50131-000, 50132-000

Adj. Range: 3/8" **Required:** 1 set per wheel

Includes: 2 (two)-five piece kits

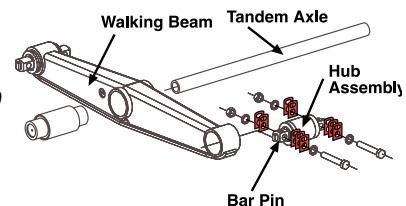

Heavy Duty

WHEEL CENTERING PRODUCTS

- Wheel Vibrations?
- Wheel Hop?
- Brake Pedal Pulsations?
- Erratic Tire Wear?
- Excessive Fuel Consumption?

If you are experiencing these problems, it may be because your wheels aren't centered on the hub. And if your wheels aren't centered, you will continue to experience these problems. With **Specialty Products' Wheel Centering Products**, you can re-center your wheel, and eliminate all of these problems.

Benefits...

- Increases fuel mileage
- Increases tire life
- Decreases tire vibration
- Cuts rebalancing costs
- Reduces "wheel-off" condition
- Reduces tire cupping

Perfect for...

- Semi Trucks and Trailers
- Heavy & Medium Duty Trucks
- Parcel Package Trucks
- Emergency Vehicles
- Commercial Buses
- School Buses
- Motor Coaches

Install our wheel centering products on your truck or fleet and start saving money NOW! Simply the BEST solution for tire vibration and erratic wear.

SPC 'EZ ON' Wheel Centering Tool Set

- 32111** OTR Vehicles
22mm
- 32115** Ford F450/F550
Super Duty
14mm
- 32116** Alcoa Wheels
made in
Hungary
22mm

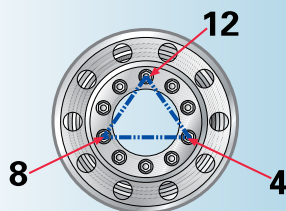

Stop wheel hop and vibrations on hub piloted wheels! Hub pilot hole diameter tolerances can allow wheels to be installed and tightened in an "off center" or clocked position. The 32111 threadless wheel centering tool set (3) fits 22mm studs on Heavy Duty and Over-the-Road Tractors and Trailers. The 32115 is for Ford F450/F550 Super Duty. These tools slide directly over the wheel studs in the 12, 4, and 8 o'clock positions. The wheel is then installed over the tools, the stud nuts added to the exposed studs and tightened. The wheel is now centered precisely. The centering tools are removed and the final stud nuts are added, torquing all nuts to manufacturer's specifications.

Features

- Threadless Design
- Tapered Nose
- Single Set

Benefits

- Saves Installation Time
- Eases Wheel Mounting
- For Steer, Drive & Trailer Axles

32111
32115
32116



Our threadless design allows the installer to quickly and easily center the wheels to the hub. And our tapered design makes it easy to mount the wheel over the hub.

Heavy Duty

WHEEL CENTERING PRODUCTS

How it works

If your hub piloted wheel is sitting on the hub stud off-center (as shown in the illustration to the right) you need these parts and tools to avoid wheel hop and excess tire wear, and to increase your fuel mileage.

The theory behind the hub pilot is that it centers the wheel. The fact is gravity causes the weight of the wheel to rest only on the upper pilots creating a gap in the bottom pilots. Even the smallest gap results in an egg-shaped motion upon rotation. This uneven motion creates rolling resistance which causes tire vibration, increased fuel consumption and erratic tire wear. The bottom line is, you can't balance an egg.

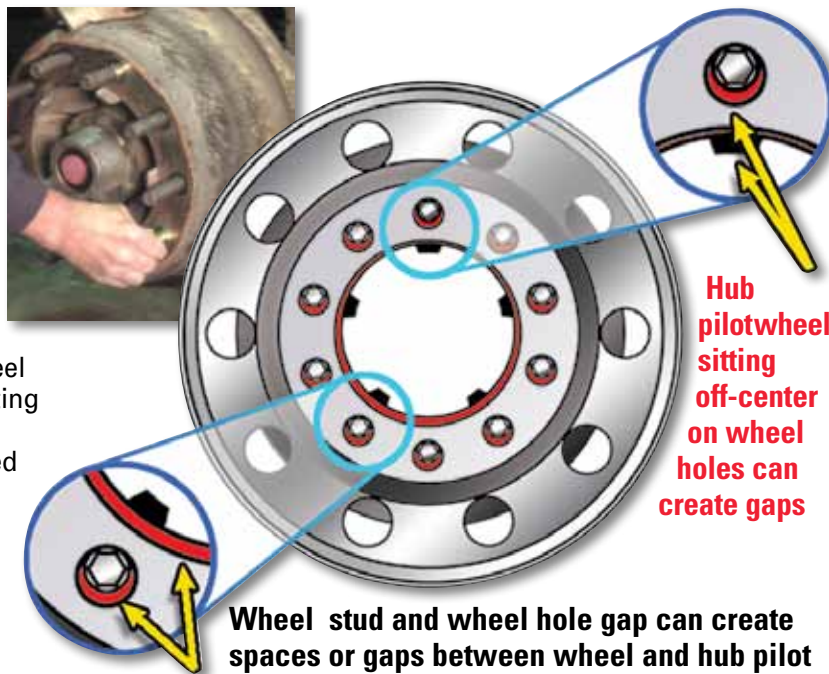

Hub pilot/wheel sitting off-center on wheel holes can create gaps

Wheel stud and wheel hole gap can create spaces or gaps between wheel and hub pilot

When the wheel rests on the upper hub pilot this produces a gap at the other pilots resulting in an off-center condition. This causes wheel vibration and erratic tire wear.

SPC 'EZ ON' Wheel & Brake Drum Centering Sleeves

These sets center both steer axle HD wheels and brake drums to minimize wheel vibrations, brake pedal pulsations, and wheel hop. For both Aluminum and Steel steer wheels and a variety of brake drum types.



This threadless sleeve design allows the installer to quickly and easily center wheels and brake drums - a great time saver and affordable!

22mm Steer Wheel - Brake Drum Type	Dimensions	Aluminum Part No.	Steel Part No.	Qty.
Gunite 3573X, 3596X, 3597X, 3598X, 3686X, 3687X, 3710X, 3721AX, 3726X, 3758X, 3774X, 3800X Webb 61528B, 65548B Arvin Meritor 53-123448-002, 53-123567-002, 53-123568-002	1.25" hole/.5" depth	32120	32124	6
Gunite 9000X, 9001X, 9035X Motor Wheel Centrifuse 89870BK, 90089BK, 90174BK Arvin Meritor 53-123512-002, 53-123542-002	1.25" hole/.25" to .3125 depth	32121	32122	6
Conmet 10009920	1.34" to 1.37" hole /.5" depth	32125	32126	6
Conmet 107164, 107453, 107507, 107862, 10001781, 10001783, 10005331, 10005332	1.28" hole /.5" depth	32127	32128	6
Gunite 3596BX, 3753AX, 3754AX	1.00" hole/.5 depth	32123		6
19.5mm Steer Wheel - Brake Drum Type				
'TAG' axles with Accu-Ride 19.5" wheels.	1.00" hole/up to .5 depth	32131		6

Heavy Duty WHEEL CENTERING PRODUCTS

STEER & DRIVE EXTERNAL SLEEVES

For steer and drive axles. This wheel centering sleeve slides over the studs and seats against the wheel face. This sleeve stays on the wheel and helps to reduce "wheel-off" condition. Sold in sets of 6 per axle. Zinc plated to resist corrosion.

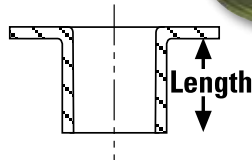

Wheel type	Stud Threads	Length Decimal	Length Fraction	Axle Position	Part No.
HEAVY DUTY					
Steel	22mm	.350"	23/64"	Steer	33140
Aluminum (see #33147 for smaller diameter sleeve)	22mm	.830"	53/64"	Steer	33141
Steel/Steel (see #33147 for smaller diameter sleeve)	22mm	.830"	53/64"	Drive	33141
Aluminum/Aluminum	22mm	1.560"	1-9/16"	Drive	33142
Aluminum/Steel	22mm	1.180"	1-3/16"	Drive	33143
"Heavy Duty" Aluminum - Michelin X One, 14" wide	22mm	1.100"	1-7/64"	Drive	33144
"Heavy Duty" Steel - Michelin X One, 14" wide	22mm	.600"	39/64"	Drive	33145
"Heavy Duty" Steel	22mm	1.440"	1-7/16"	Steer & Drive	33146
Aluminum (.010 smaller diameter than #33141)	22mm	.830"	53/64"	Steer	33147
Steel/Steel (.010 smaller diameter than #33141)	22mm	.830"	53/64"	Drive	33147
Alum. Wheel & Brake Drum (cent. wheel & drum)	22mm	1.310"	1-5/16"	Steer & Drive	33148
Aluminum Gunitite Brake Drums #s 3753AX, 3754AX, Freightliner FL60, FL70 & M2, 3596BX & others	22mm	1.310"	1-5/16"	Steer	33149

WHEEL CENTERING ACCESSORIES

These accessories will make installing our centering sleeves fast and easy.

#33171 ELECTRIC DRILL WIRE BRUSH

Use to clean holes before mounting.



#33172 DEBURR KNIFE

Use to remove damaged edges.



HEAVY DUTY WHEEL CENTERING TOOLS - EDUCATION COUNTER MAT

Create extra sales at the counter with this great teaching tool from SPC. This high quality mat explains the problems caused by off-centered wheel and the benefits of using our Wheel Centering Sleeves and includes a quick guide to our Axle and Tandem Shims on the reverse.

Dimensions: 11" x 17"



20106

Heavy Duty

TOOLS 64250

Machined roller & heavy duty tripod for smooth, accurate readings

33174 - Replacement Gauge - Page 179

Includes ball joint/tie rod extenders

UNIVERSAL RADIAL RUN-OUT GAUGE

The Universal Radial Run-Out Gauge displays exact measurements for tire, wheel, and disc brake run-out. This gauge also measures ball joint and tie rod play and adjusts height to adapt to both automotive and heavy truck applications. This is a great tool when measuring those hard to reach areas.

Tire Radial Run-Out

- Measures out of round condition which can cause front end vibration
- Pinpoints high and low spots in the tire

Suspension/Ball Joint Play

- Measure kingpins, ball joints and tie rod end axial and radial play
- Use extender rods for hard to reach areas

Wheel Lateral Run-Out

- Check for bent or out of round wheels
- Out of round wheels may cause a shimmy condition

Brake Rotor and Hub Run-Out

- Measure brake rotor high spots & out of round
- Measure hub radial play



75555 75560 75580 75585



75555

75560

75580

75585

HEAVY DUTY TORQUE EXTENSIONS

These heavy duty torque extensions provide a fast, simple method to achieve manufacturers' specified torque every time using an impact wrench. No more guesswork! These extensions feature solid one piece construction.

#75555 140 ft. lbs. torque - 1/2" drive - aqua

#75560 160 ft. lbs. torque - 1/2" drive - orange - extension for: 1999 & Up Ford Super Duty Trucks and 2000 - 2005 Excursions

#75580 400 ft. lbs. torque - 1" drive - yellow

#75585 550 ft. lbs. torque - 1" drive - yellow

See page 184 for our Wheel Torque Chart part no. 70050

81309



STEEL WHEEL RIM STRAIGHTENING TOOL

For quick and easy removal of indentations on wheel flanges and rims of most vehicles. Allows proper tire seating, giving greater tire protection. Powder coated for added durability.

83125



TRUCK WHEEL WEIGHT TOOL

Special grip hammer and pliers for removal and installation of truck wheel weights.

83788



CHROME LUG NUT COVER TOOL

No-Mar coated jaws allow harmless removal and installation of chrome nut covers on light truck, motor home, and over-the-road truck lug nuts.

84238

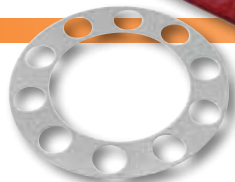

NO MAR RIM GUARD

Protects from scratching chrome, aluminum, and painted truck wheels when removing lug nuts.

FASTRAX™ CAMBER/CASTER GAUGE

This great tool is a must for your garage or shop. Accurate, portable, alignment checks can be done quickly and easily with the FasTrax™ Adjustable Camber/Caster Gauge.

- Includes gauge and wheel mount (fits most wheels from 21" to 26"). Includes extra length toe arms, heavy duty tape measure, and no lip adapters
- Displays Camber $\pm 4^\circ$ / Caster -4° to $+12^\circ$.
- Saves time and tires.
- Accurate, rugged and easy-to-use.

- *The most expensive costs of operating a fleet today is fuel and rubber*
- *By adding 5 minutes to your PMs you can protect your steer tires from premature wear and increase fuel mileage*
- *For less than the price of one steer tire you can **SAVE THOUSANDS OF DOLLARS PER YEAR!***



Perfect to add to your PMs - Check your alignment in just 5 minutes!!!!

S-CAM BUSHING EXTRACTOR

91860

Great tool for any Heavy Duty shop that works on low boys, reefers, log trucks and more. Now you can remove and replace the S-Cam bushing on air brake equipped trailers without removing the wheel hub or replacing the wheel seal. Save time and money yourself and for your customer with this innovative durable tool. Offer S-Cam replacement with every brake job.



Dimensions:
1-7/9" OD •
1-3/8" ID

Tandem Axle Measurement Tools

KINGPIN EXTENSION / LOW PROFILE

91887

This kingpin extension is for low profile trailer and car carriers. For simple and fast, accurate measurements from the kingpin center to the trailer tandems (to be used with **91891** and **91999**).

Height 13-1/4" 3" Spring Motion



TRAILER KINGPIN EXTENSION

91889

The trailer kingpin extension makes simple, fast, accurate measurements from the kingpin center to the trailer tandems. Adjustable in length and has a spring-loaded cone that assures accurate holding to the kingpin (to be used with **91891** and **91999**).

Maximum Height 48" 3" Spring Motion 6 Adjustments in 2" Increments



TANDEM AXLE CALIPER

91891

This light weight aluminum caliper is used to check the spacing between the axles of tractors or trailers for alignment and tracking. It has an easy to read scale in both metric and inches, with a range of 72". To be used with **91887**, **91889** and **91999**.



TANDEM TRACKER TOOL FOR HUB PILOTTED WHEELS

91999

Quickly take tandem axle measurements with this innovative heavy duty alignment tool. Simply thread the tool onto two opposing lug studs, then tighten down the centerline indicator and measure from the kingpin to get your measurements. This tool saves time and money over traditional alignment methods and is compatible with both 8 and 10 lug hub piloted tandem axles. Recommended to be used with **91887** or **91889** kingpin extension tools.

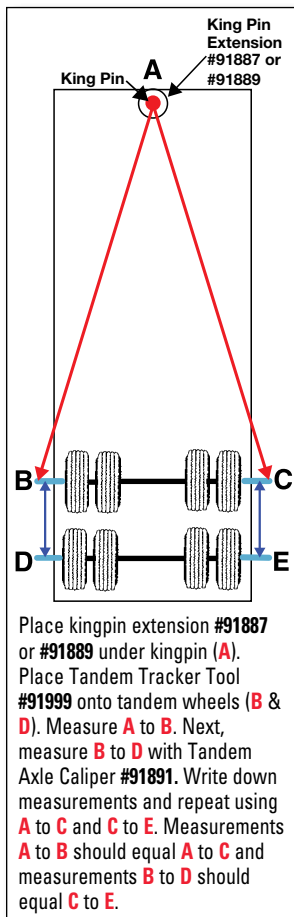

Replacement

REPLACEMENT PARTS

Applications

Alignment Parts

Heavy Duty

OE Replacement

Racing/Builders

Tools

Brake and CV

Coax/Index

12020

Rear Lower Control Arm

REAR LOWER CONTROL ARM INFINITI OE REPLACEMENT

Replace a worn or bent rear lower control arm (OE# 551A01MA0D) on the Infiniti Q50 and Q70 with SPC's high strength steel stock length control arm (#12020). Need extended camber adjustment? Consider SPC adjustable link #72245 (page 109).

12021

Rear Radius Rod

REAR RADIUS ROD INFINITI OE REPLACEMENT

Replace a worn or bent rear radius rod (OE# 551B01MA0D) on the Infiniti Q50 and Q70 with SPC's high strength steel stock length control arm (#12021). Need set-back adjustment? Consider SPC adjustable link #72250 (page 109).

12022

Rear Lateral Arm

REAR LATERAL ARM INFINITI OE REPLACEMENT

Replace a worn or bent rear lateral arm (OE# 551201MA0D) on the Infiniti Q50 and Q70 with SPC's high strength steel stock length control arm (#12022). Need toe adjustment? Consider SPC adjustable link #72255 (page 109).



12020 Rear Repl. Part

Required: 1 per wheel

12021 Rear Repl. Part

Required: 1 per wheel

12022 Rear Repl. Part

Required: 1 per wheel

APPLICATIONS

Infiniti: 2014 - Up Q50
2014 & Up Q70
2011 - 13 M35h,
M37, M56

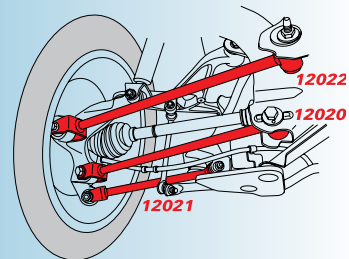

12025

TC FIXED LENGTH REAR ARM

Replace your worn or bent rear upper control arm (OE# 4877021011) on the Scion tC. This arm features rubber bushings to match OE design and performance. Need positive camber change? Consider SPC offset arm #67485 (page 95).



Rear Replacement Part

Required: 1 per wheel

APPLICATIONS

Scion: 2005 - 10 tC

12030

SCION/LEXUS/TOYOTA FIXED LENGTH REAR ARM

Replace your worn or bent rear upper control arm (OE# 4877012010) on the Scion tC and iM, as well as the Lexus CT and HS vehicles. This arm features xAxis™ and rubber bushings to match OE design and performance. Need camber adjustment instead? Consider SPC adjustable link #67487 (page 96).

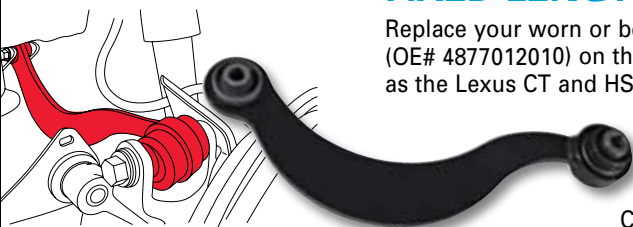

Rear Replacement Part

Required: 1 per wheel

APPLICATIONS

Lexus: 2011 & Up CT
2010 - 12 HS
Scion: 2011 - 16 tC
2016 iM
Toyota: 2017 - 18 Corolla iM

12050

FIXED LENGTH MUSTANG TOE LINK

Replace your worn or damaged rear lower control arm on the S550 Ford Mustangs with this forged T6 aluminum replacement arm from SPC. The arm features a xAxis™ sealed flex joint and replacement nut and bolt for easy replacement and factory noise, vibration and harshness (NVH). Check out all our adjustable alignment parts for 2015 & up Mustangs on page 112.



Rear Replacement Part

Required: 1 per wheel

APPLICATIONS

Ford: 2015 & Up Mustang



Rear Replacement Part

12116 RIGHT
12017 LEFT

Required: 1 per wheel

APPLICATIONS

BMW: 2007 & Up X5
2007 & Up X6

BMW OE REPLACEMENT ARM

Replace your worn or damaged left rear upper control arm on BMW X5 and X6 models with this high quality SPC replacement arm. This arm features a bonded rubber bushing and maintenance free ball joint to match OE design and performance. Many X5 and X6's are running negative camber because the rear upper arm's bushing and BJ are worn, replace it with SPC's arm and you can take advantage of the second bushing hole for +2° camber. Need more camber adjustment? Use SPC p/n 72115 for a complete rear end adjustment kit, p/n 72116 for a right side or p/n 72117 for a left side adjustable arm (page 107).

RIGHT 12116
LEFT 12117

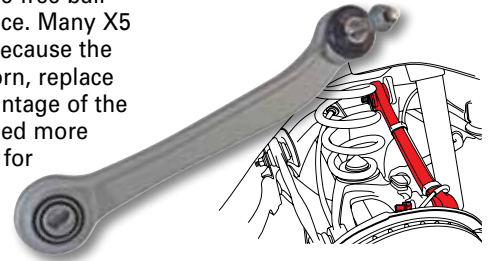

Rear Replacement Part

Required: 1 per wheel

APPLICATIONS

AWD ONLY

Ford: 2005 - 07 Five Hundred
2005 - 07 Freestyle
2008 - 09 Taurus
2008 - 09 Taurus X
Mercury: 2005 - 07 Montego
2008 - 09 Sable

FORD REAR UPPER BALL JOINT REPLACEMENT

Replace your worn out upper ball joints on the rear suspension of popular Ford and Mercury AWD vehicles with these replacement ball joints from SPC. Ford makes you buy the whole knuckle to replace this joint, but you can save time and money by simply replacing the ball joint instead. Need camber adjustment as well? Check out SPC #67690 for a camber adjustment ball joint that offers ±1.25° degrees of change (page 101).

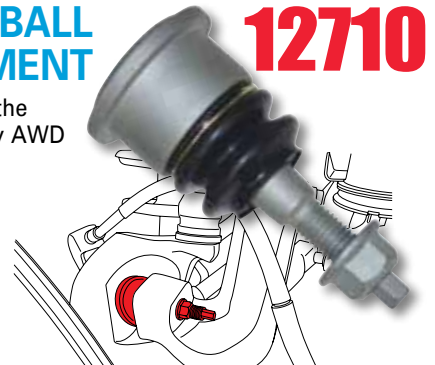

Front Replacement Part

Required: 1 per wheel

APPLICATIONS

Honda: 2018 Accord
2016 & Up Civic (not Type R)
2017 & Up CR-V

DOES NOT FIT CIVIC TYPE R

HONDA REPLACEMENT LOWER BALL JOINT

Replace your worn or damaged factory lower ball joint on the front of the late model Civic, CR-V, or Accord with this replacement ball joint from SPC. This ball joint uses high quality components for a long service life. Need camber adjustment as well? Consider our line of camber adjustment ball joints; 67381 for negative camber or 67382 for positive camber (page 92).

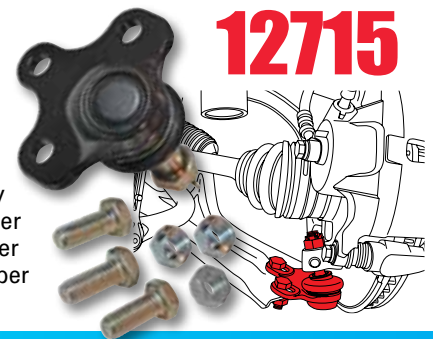

REAR Replacement Part

Required: 1 per wheel

APPLICATIONS

Subaru: 2003 - 06 Baja
2013 - 18 BRZ, Crosstek
2009 - 18 Forester
2008 - 18 Impreza (inc STI, WRX)
2010 - 18 Legacy, Outback
2009 - 14 Tribeca

SUBARU REPLACEMENT BUSHING

Replace the worn bushing on the onboard in of the rear lower control arm on many Subaru models from the 2000's. Need the toe cam adjuster too? Check out 67668 on page 100.

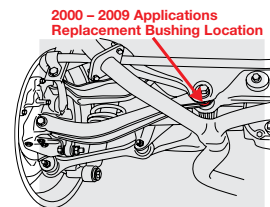

2000 - 2009 Applications
Replacement Bushing Location

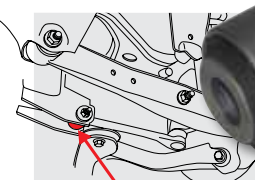

2010 - 2018 Applications
Replacement Bushing Location

16210

Self-Adhering Mouse Pad

7.5" x 8.5"

SPC REPLACEMENT PARTS MOUSEPAD

SPC's adjustable arms are the standard in adjustable alignment solutions, but they are also the perfect choice when replacing worn or damaged stock arms. Selling into the replacement market expands your market reach and can introduce techs to SPC's full line of parts.



Applications

Alignment Parts

Heavy Duty

OE Replacement

Racing/Builders

Tools

Brake and CV

Year Index

21020

FORD F-SERIES FRONT COIL SPRING BOLT

When installing coil spring spacers on older F150s with Twin I Beam suspension you may need a longer spring retainer bolt. This replacement bolt is 10" long, long enough to provide plenty of bolt length to compensate for the added thickness of the coil spring spacer.

Rear Replacement Part

Required: 1 per wheel

APPLICATIONS

Ford: F150s with Twin I-Beam Suspension

21035

BOLT & NUT KIT/NISSAN (PR)

The upper control arm mounting bolts on many Nissan trucks and SUVs are frequently corroded and must be cut out when removing or replacing the control arm. This bolt and nut replacement kit (2) allows easy re-installation of the upper control arm. The pair of bolts and nuts are enough to replace both bolts in one corner or to replace the rearward bolt on both upper control arms if you are cutting them out to replace both arms. Can be used with SPC Adjustable Front Upper Control Arm, part number 25540 (page 82).

Front Replacement Part

Required: 1 per wheel

APPLICATIONS

Nissan: 2004 - 15 Armada
2005 & Up Frontier
2005 - 12 Pathfinder
2004 - 15 Titan
2005 - 15 Xterra
Suzuki: 2009 - 12 Equator

21040

AUDI FRONT UPPER CONTROL ARM PINCH BOLT KIT

The upper control arm ball joint pinch bolt on the popular Audi A4 & A5 models is frequently corroded and must be cut out when removing or replacing the upper arms. This bolt and nut replacement kit has a 720 hour saltspray certified coating to minimize future corrosion. Order one kit per side. Included with SPC Adjustable Front Upper Control Arms (page 119).

Front Replacement Part

Required: 1 per wheel

21040 APPLICATIONS

REPLACE AUDI OE BOLT N10425302 AND NUT N10286110 WITH THIS KIT.

Audi: 1998 & Up A4; 2000 & Up S4
2007 - 08 RS4; 2007 & Up A5/S5
1998 - 11 A6/Allroad/S6/RS6
2012 & Up A7/S7; 2004 - 10 A8/S8
2009 & Up Q5; 2013 & Up SQ5

Volkswagen:

1998 - 05 Passat; 2004 - 06 Phaeton

21045 APPLICATIONS

REPLACE AUDI OE BOLT WHT006542 AND NUT N10286110 WITH THIS KIT.

Audi: 1998 & Up A4; 2000 & Up S4

21045

25945 25950 25955 25960 25965

TOYOTA REAR LOWER CONTROL ARMS (PR)

These pairs of rear lower control arms are direct replacements for weak or bent factory units. Made of 3/16" wall DOM tube, they are more than 2x stronger than the OE arms! They are equipped with a rubber bushing in one end for isolation of road noise and an xAxis™ sealed flex joint in the other end for superior flexibility off road. Whether you are replacing damaged OE parts or upgrading for offroad use, these are the arms for you. Need articulation or alignment changes in the front? Check out our front adjustable upper control arms (page 81).

Rear Replacement Part

Required: 1 per axle

25945 APPLICATIONS

Toyota: 1996 - 02 4Runner

25950 APPLICATIONS

Lexus: 2003 & Up GX
Toyota: 2003 & Up 4Runner
2007- 14 FJ Cruiser

25955 APPLICATIONS

Toyota: 1998 - 07 Landcruiser (100 Series)

25960 APPLICATIONS

Toyota: 1991 - 97 Landcruiser (80 Series)

25965 APPLICATIONS

Lexus: 2008 & Up LX 570
Toyota: 2008 & Up Landcruiser (200 Series)

25945
25950

25955, 25960,
25965

Rear/Front Upper Replacement Part

Required: 1 per wheel

67075 APPLICATIONS

REAR Acura: 1996 - 04 CL; 1996 - 08 TL
1992 - 94 Vigor

REAR Honda: 1990 - 02 Accord

FRONT Acura: 1996 - 04 CL; 1999 - 08 TL

FRONT Honda: 1998 - 02 Accord; 1996 - 00 Civic
1988 - 91 Civic; 1989 - 92 CRX
1995 - 98 Odyssey

67245 APPLICATIONS

FRONT Acura: 1990 - 01 Integra; 1991 - 96 Legend
1996 - 01 RL; 1996 - 98 3.2TL

Honda: 1992 - 00 Civic; 1997 - 01 CR-V
1992 - 97 Del Sol; 1997 - 02 Prelude

REPLACEMENT BALL JOINTS

67075 67245

These ball joints can be used as a replacement ball joint for several Honda and Acura vehicles. The 67075 can be used as a replacement ball joint for SPC's **67065** (page 87) and **67265** (page 90) adjustable arms.



We have adjustable ball joints for these vehicles and more - check them out on pages 89 and 92



40920 - Perf. Ball Joint Press, pg 165

Rear Replacement Part

Required: 1 per axle

69300 APPLICATIONS

Acura: 2001 - 05 EL
Honda: 2001 - 05 Civic

69400 APPLICATIONS

Acura: 2002 - 06 RSX
Honda: 2002 - 06 CR-V
2003 - 11 Element

HONDA/ACURA REAR LOWER ARMS (PR)

69300 69400

These lower control arms are for Honda Civics, CR-Vs and Elements along with Acura RSXs. Made from aircraft aluminum alloy.

These sets of lower arms include a special socket, Part 69330 (page 168) which is required for installation.



Socket Included



Rear Replacement Part

Required: 1 per axle

APPLICATIONS

Ford: 1999 - 04 Mustang
Cobra



Need to adjust front camber or caster? Check out our adjustable strut mounts, part number 72060 on page 107

COBRA IRS XAXIS™ JOINT KITS

72062

Set of 4 with Adaptors

Replace worn rear knuckle cross axis ball joints on the IRS Mustang Cobra with xAxis™ joints from SPC Performance. SPC's cross axis ball joints feature highly polished electro-less nickel plated balls, corrosion and wear resistant moly impregnated nylon races, and dust boots to keep contaminants out & ensure long life. xAxis Joints come pre-greased and are designed to be maintenance free. Order part #72062 for the complete set to replace all 4 rear knuckle cross axis ball joints, along with the correct press tool adaptors. Need only a single rear knuckle ball joint? Order part #15645. With the single xAxis use SPC press adaptors part number 29606 and 29610 to make installation a snap. Don't have a press tool? Use SPC #40940.



40920 - Perf. Ball Joint Press, pg 165

15645

Single Joint



Rear Replacement Part

Required: 1 per axle

87550 APPLICATIONS

Ford: 2002 - 05 Thunderbird
Lincoln: 1999 - 06 LS

87555 APPLICATIONS

Jaguar: 1999 - 08 S-Type

Front Cam Kits are available for these applications (#87535), page 133

XAXIS™ JOINT KITS

87550 87555

Replace worn rear lower control arm cross axis ball joints on the Lincoln LS and Ford Thunderbird (#87550) or Jaguar S-Type (#87555) with xAxis™ Sealed Flex Joints. SPC's xAxis joints are pre-greased and feature highly polished electro-less nickel plated balls, moly impregnated nylon races, and dust boots to keep contaminants out & ensure long life. These kits include four (4) xAxis joints and two (2) press tool adaptors to service a complete rear end.

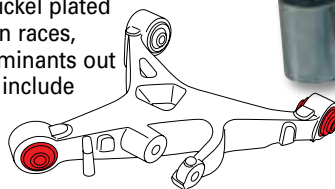

40920 - Perf. Ball Joint Press, pg 165



Race Style Adjustable Upper Control Arms

These fully adjustable, rugged arms are recommended for circle track, road racing and drag applications. They allow the user to adjust the arm length and offset to attain the ultimate suspension geometry required to reach the winner's circle. Each arm can be adjusted up to 2" in length and all components are interchangeable and may also be ordered separately - see pages 156-157. **SPC also offers arms for Muscle Cars, Street Rods, Corvettes and show applications - see our Application Guide (pages 7-70) for more!**



Follow the steps below to determine the correct control arm needed for your chassis.

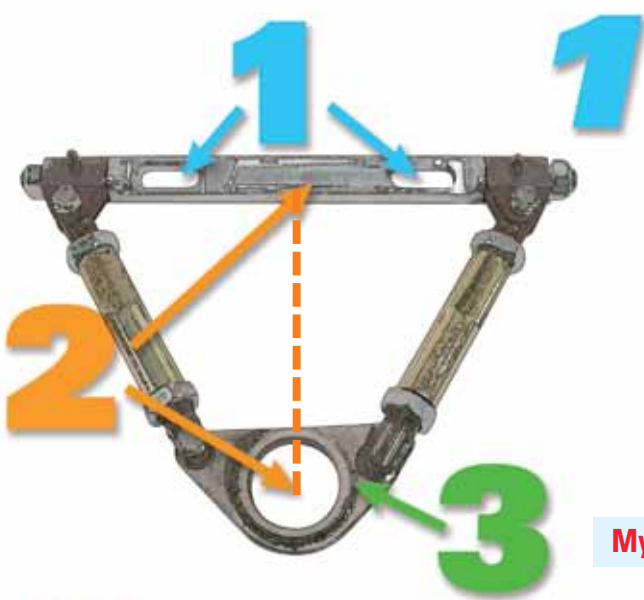

Step Number 1: Measure Cross Shaft Bolt Hole Spacing From Center-To-Center

SPC Performance offers these cross shafts including grease fittings with bolt hole spacings of:

- 5"
- 6" (slotted) *Aluminum* or 5-7/8" - 6" (slotted) *Steel*
- 6 1/2" (*1st Gen 'F' Body 1967-69 Camaro; 1968-74 Nova-'A' Body Chevelle, El Camino, GTO, Olds 442*)
- 6-15/16" *Metric Stubs ('G' Body 1978-88 Chevelle, Grand National, Malibu Grand Prix; 1970-88 Monte Carlo; 1979-87 Cutlass Supreme)*
- 7-3/4" *2nd Gen 'F' Body (1970-81 Camaro, Firebird)*

My Cross Shaft Spacing Is: _____

Step Number 2: Measure Length of Control Arm

Measure from the middle of the cross shaft to the center of the ball joint.

- Steel Adjusting Sleeve lengths are available in 3-3/4", 5", 6", 8", and 9". Also available in black anodized aluminum in 4", 5" and 6" lengths.

My Control Arm Length Measures: _____

Step Number 3: Determine Type of Ball Joint Plate

- **Full Sized GM Truck Bolt In Ball Joint Plate** Measure center-to-center between the ball joint bolt holes that are farthest apart. This measurement should be 2-3/4" SPC Ball Joint part number is **92004**.
- **GM Metric (Midsized) Bolt In Ball Joint Plate** Measure center-to-center between the ball joint bolt holes that are farthest apart. This measurement should be 2-1/2" - SPC Ball Joint part #**92006**. Also in 20° - SPC Ball Joint part #**92008 & 92009**.
- **Chrysler Screw In Ball Joint Plate** - SPC Performance offers ball joint plates that are welded flat (0° - SPC part #**92003**) or at an angle (10° - SPC part #**92002**) for these screw in type ball joints.

My Type of Ball Joint is: _____

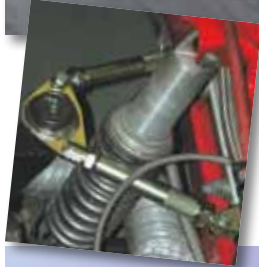

SPC Performance offers preassembled arms in the most popular configurations. These arms are fully adjustable and can give you all the camber and caster change you need to fine tune your alignment for any track. You will save time by being able to quickly and accurately dial in your alignment angles and at the same time you will improve your handling and tracking.

SPC Performance Arms Feature:

- Quality Steel or Aluminum (6" only) Cross Shaft with Pro Racing pivot assemblies or optional high strength rod ends with 3/4-16 thread and 5/8" bore
- Threaded steel adjusting sleeves
- Ball joint plates for Full Size, Screw-In or Metric Types

To order - find the **Cross Shaft** (or Rod End), **Adjusting Sleeve** and **Ball Joint Plate** that your chassis requires... it is that easy!

Don't see the combination that your vehicle requires? Check out our components - available individually - **and build your own!** (See more on our high quality components on pages 156 & 157.)

Part No.	Step 1 Your cross shaft	Step 2 Your Sleeve	Step 3 Ball Joint Plate
92142	5" Steel Cross Shaft	3-3/4" Adj Sleeve (Adjusts to 7"-9")	Chrys. 10° Screw-In Ball Joint
92244	6" Steel Cross Shaft	3-3/4" Adj Sleeve (Adjusts to 7"-9")	GM Full Size Ball Joint
92242	6" Steel Cross Shaft	3-3/4" Adj Sleeve (Adjusts to 7"-9")	Chrys. 10° Screw-In Ball Joint
92254	6" Steel Cross Shaft	5" Adj Sleeve (Adjusts to 8-1/4"-10")	GM Full Size Ball Joint
92252	6" Steel Cross Shaft	5" Adj Sleeve (Adjusts to 8-1/4"-10")	Chrys. 10° Screw-In Ball Joint
92546	6-15/16" Steel Cross Shaft	3-3/4" Adj Sleeve (Adjusts to 7"-9")	GM Midsize Metric Ball Joint
92542	6-15/16" Steel Cross Shaft	3-3/4" Adj Sleeve (Adjusts to 7"-9")	Chrys. 10° Screw-In Ball Joint
92556	6-15/16" Steel Cross Shaft	5" Adj Sleeve (Adjusts to 8-1/4"-10")	GM Midsize Metric Ball Joint
92552	6-15/16" Steel Cross Shaft	5" Adj Sleeve (Adjusts to 8-1/4"-10")	Chrys. 10° Screw-In Ball Joint
92646	7-3/4" Steel Cross Shaft	3-3/4" Adj Sleeve (Adjusts to 7"-9")	GM Midsize Metric Ball Joint
92656	7-3/4" Steel Cross Shaft	5" Adj Sleeve (Adjusts to 8-1/4"-10")	GM Midsize Metric Ball Joint
92344	6" Aluminum Cross Shaft	3-3/4" Adj Sleeve (Adjusts to 7"-9")	GM Full Size Ball Joint
92342	6" Aluminum Cross Shaft	3-3/4" Adj Sleeve (Adjusts to 7"-9")	Chrys. 10° Screw-In Ball Joint
92354	6" Aluminum Cross Shaft	5" Adj Sleeve (Adjusts to 8-1/4"-10")	GM Full Size Ball Joint
92352	6" Aluminum Cross Shaft	5" Adj Sleeve (Adjusts to 8-1/4"-10")	Chrys. 10° Screw-In Ball Joint
92044	Hi Strength 2 Pc. Rod End	3-3/4" Adj Sleeve (Adjusts to 7"-9")	GM Full Size Ball Joint
92042	Hi Strength 2 Pc. Rod End	3-3/4" Adj Sleeve (Adjusts to 7"-9")	Chrys. 10° Screw-In Ball Joint
92043	Hi Strength 2 Pc. Rod End	3-3/4" Adj Sleeve (Adjusts to 7"-9")	Chrys. 0° Screw-In Ball Joint
92046	Hi Strength 2 Pc. Rod End	3-3/4" Adj Sleeve (Adjusts to 7"-9")	GM Midsize Metric Ball Joint
92054	Hi Strength 2 Pc. Rod End	5" Adj Sleeve (Adjusts to 8-1/4"-10")	GM Full Size Ball Joint
92052	Hi Strength 2 Pc. Rod End	5" Adj Sleeve (Adjusts to 8-1/4"-10")	Chrys. 10° Screw-In Ball Joint
92053	Hi Strength 2 Pc. Rod End	5" Adj Sleeve (Adjusts to 8-1/4"-10")	Chrys. 0° Screw-In Ball Joint
92056	Hi Strength 2 Pc. Rod End	5" Adj Sleeve (Adjusts to 8-1/4"-10")	GM Midsize Metric Ball Joint

We also have pre-built arms for Corvettes - See Page 140!



Builders

Build your own Arm

With our high quality components

If we don't have a pre-assembled arm with the specs you need you can purchase the individual components and get exactly the configuration you want for racing, hot rod, street or drag.



Our chromoly cross shafts are lighter and stronger - perfect for racing or street.

Cross Shafts

Steel or aluminum cross shafts in a variety of sizes and configurations including grease fittings or bushings. Measurement is from center to center on holes.

Complete Cross Shaft Assemblies

94100 | 5" Steel Stock/Mustang II | Includes 2 Straight Pivots

Customizable Cross Shafts

Part#	Shaft Hole Spacing	Shaft Material	Racing Pivots (Order 2) Delrin Bushing Offset Style	Street Pivots (Order 2) Clevite Bushing Offset Style
93400	5"	Steel	92025	94014
93410	5-1/2"	Steel	92025	94014
93420	5-7/8" to 6"	Steel	92025	94014
93440	6" <i>Slotted Mount</i>	Aluminum	92025*	N/A
93430	6-5/16"	Steel	92025	94014
93450	6-1/2"	Steel	92025	94014
93460	6-11/16"	Steel	92025	94014
93470	6-15/16"	Steel	92025	94014
93480	7-3/4"	Steel	92025	94014
93490	5-7/8" <i>Tri-5</i>	Steel	92025	94014

* Note: On 93440 Aluminum Shafts the 92025 pivot bushings will need to be removed before installing.

Adjusting Sleeves

These sleeves are the perfect fit with our pivot studs and ball joint plates.

Sold individually.

Part #	Length	Sleeve Material	Part #	Length	Sleeve Material
92040	3-3/4"	Steel	92060	6"	Steel
92045	4"	Aluminum	92065	6"	Aluminum
92050	5"	Steel	92080	8"	Steel
92055	5"	Aluminum	92090	9"	Steel

Upper Control Arm Components

A variety of assemblies along with nuts and bolts for your arm. **Sold individually.**

Part #	Description	Part #	Description
92005	UCA End Pivot Stud (Cross Shaft End)	92025	Offset Race Pivot Assembly w/Delrin Inserts
92010	Right Hand Jam Nut - 3/4" - 16	94013	OE Style Bushing Only
92011	Left Hand Jam Nut - 3/4" - 16	94014	Offset Street Pivot Assembly w/OE Style Bushings
92013	Pivot Plate Stud w/Nut	94041	Street Kit (threaded studs, lock nuts, bolts, jam nuts, OE style offset pivots - 2 ea.)
92014	7/16 Hex Head Cap Screw	97100	Hi Strength 2 Piece Rod End - 3/4" - 16 LH
92019	Lock Nut for 92014		
92021	Race Kit (threaded studs, lock nuts, bolts, jam nuts, offset pivots w/Delrin Insert - 2 ea.)		



Applications

Alignment Parts

Heavy Duty

OE Replacement

Racing/Builders

Tools

Brake and CV

Gear/Index

Builders

Ball Joint Plates

SPC Ball Joint plates come in a variety of styles to complete your adjustable control arm along with OE style ball joints (sold separately-below).

W-I-D-E 10 & 20 degree screw in ball joint plates accommodate larger coil springs being used on many late model racing chassis. The wide plate allows plenty of room for both caster and offset adjustment.

Part #	Type	Use with these Ball Joints (not included)
92002	Chrysler Screw In Plate - 10°	94002
92003	Chrysler Screw In Flat Plate - 0°	94002
92004	Full Size GM Bolt In Plate	94004 standard
92006	Midsize GM Metric Bolt In Plate - 0°	94006 standard, 94017 extended
92007	GM Tri 5 Bolt In Plate	94003
92008	Left Midsize GM Metric Bolt In Plate - 20°	94006 standard, 94017 extended
92009	Right Midsize GM Metric Bolt In Plate - 20°	94006 standard, 94017 extended
92033	Wide Mouth Screw-In Plate - 10° (Right)	94002 (for larger coil springs)
92035	Wide Mouth Screw-In Plate - 20° (Drivers)	94002 (for larger coil springs)



Ball Joints

.5" Extended Length OE Style Ball Joints

These greaseable, OE style extended length ball joints are ideal to improve camber gain and increase control arm to frame clearance.

Ideal for the ultimate in handling performance.

Part #	Description
94016	Lower Ball Joint for GM 'A' Bodies (Press in for 94344 Lower Arm)
94018	Lower Ball Joint for GM 'G' Bodies (Press in for 95336 Lower Arm)
94017	Upper Ball Joint for GM Mid Size Bolt In Metric Plate
94019	Upper Ball Joint for GM 1st Gen 'F' Body & 'A' Body ('64 -'72)



OE Style Ball Joints

These ball joints fit a variety of GM and Chrysler applications. If you are installing our adjustable control arms these ball joints are the perfect fit to finish your suspension upgrade or a direct fit to replace a worn ball joint on a stock arm.

Part #	Description
94001	Upper Early GM Metric Bolt-in Ball Joint
94002	Upper Chrysler Screw-In Ball Joint
94003	Upper GM C2/C3 Corvette & Tri 5 Bolt-In Ball Joint
94004	Upper GM Full-Sized Bolt-In Ball Joint
94006	Upper GM Mid-Sized Metric Bolt-In Ball Joint
94007	Upper C4 Corvette Bolt-In Ball Joint
94009	Upper Ford Mustang Ball Joint
94010	Lower A & F Body Ball Joint
94011	Lower G & 2nd Gen F Body Ball Joint

 68880 - Socket pg 168

SPC has entire suspension solutions for muscle cars and street rods. Fully adjustable, rugged upper control arms, custom designed lower control arms to improve your tracking and handling, coil springs that provide optimum rates for unsurpassed performance along with ball joints, components and more! Check pages 135-140 for our complete line!



Applications

Alignment Parts

Heavy Duty

OE Replacement

Racing/Builders

Tools

Brake and CV

Gear/Index

Builders™ xAxis™ Sealed Flex Joint



Designed to replace many OE style bushings, SPC's **xAxis™ Sealed Flex Joint** retains chassis design parameters. **xAxis™** is recommended for use as a replacement when higher performance of joint angularity is desired - perfect for race and off-road builders.

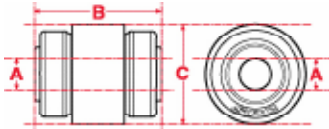

Features

- **Sealed joint retains grease and keeps out contaminants**
- **Highly polished electroless-nickel finish on ball maximizes durability**
- **Up to 45° angularity for high mis-alignment requirements**
- **Common sizes that builders and racers need**

Benefits

- **Reduced compliance and deflection vs rubber and poly joints**
- **Improved durability vs spherical bearings and poly bushings**
- **Increased angularity vs rubber and poly bushings**
- **Engineered to be a direct fit for many popular street/race or HD off-road applications**

Electroless-nickel plated ball provides hard, smooth wear surface for long life

Corrosion and wear resistant nylon inner sleeve reduces compliance

Zinc plated retaining rings keep boot secure throughout increased joint travel

Easily replaceable rubber boots protect joint from elements



xAxis™ Sealed Flex Joint

Part No.	Bolt Size (A)		Width (B)		Outer Dia (C)		Press Adapter
	mm	Inch	mm	Inch	mm	Inch	
15605		0.375		1.500		1.250	29607
15607		0.500		2.000		1.750	29608
15609		0.625		2.500		2.000	29610
15611		0.750		3.250		2.500	29612
15613	10			2.000		1.8125	29609
15615	12			2.000		1.8125	29609
15616	14			2.375		1.8125	29609
15617*	14			1.625	38.5		29605
15619	14			2.625		2.250	29611
15623	12		40		40		29606
15624	12		48		40		29606
15625	10		40			1.750	29608
15627	12		42		40.2		29606
15629	12		45		40		29606
15631	12		47		40		29606
15633	12		50		40		29606
15635	12		50		40.2		29606
15637	12		57		40		29606
15639	14		40		40		29606
15641	14		50		40		29606
15643	12		44.5		40		29606
15647	14		48		40		29606
15648	14		50		40		29606

* Bolt hole and width are designed for JK track bar bracket.

15620 Jeep xAxis™



Designed to replace the common 2-1/4" dia x 2-5/8" wide bushings in Jeep aftermarket control arms, and accommodates a 5/8" or 16mm bolt. Uses 29611 Adapter, right.



Bushing Press Adapters

29605, 29606, 29607, 29608, 29609, 29610, 29611, 29612

These adapters are designed for quick, easy removal of the old bushings and installation of SPC's **xAxis** joints.

Weld-In Receivers with 2 Snap Rings



Use this weld in receiver to create your own control arm or chassis mount with an SPC **xAxis™** sealed flex joint. Designed with optimal press fit for the **xAxis** these receivers include two snap rings for retention and an access window for easy snap ring removal.

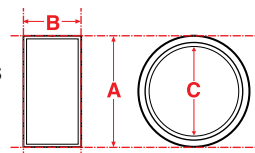

Part No.	O.D. (A)	Width (B)	ID (C)	Press Adapter
15520	1.50"	0.82"	1.25"	29607
15521	2.25"	1.12"	1.75"	29608
15522	2.50"	1.25"	2.00"	29610
15523	3.00"	1.56"	2.50"	29612
15524	2.25"	1.07"	1.8125"	29609
15525	2.75"	1.17"	2.25"	29611
15526	47.6mm	27.3mm	40mm	29606

xAxis™ Forged Receiver Assemblies

xAxis™ Forged Receiver Assemblies are the way to get all the benefits of **xAxis** Sealed Flex Joints into your project. Includes **xAxis**, forged receiver, jam nut and snap ring.

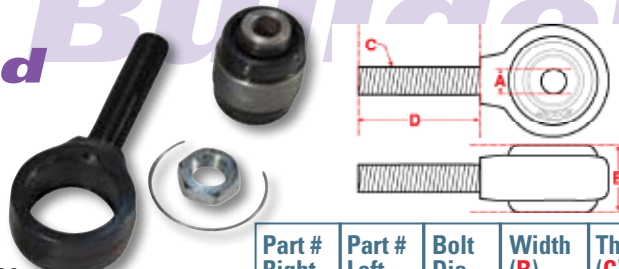

Part # Right Thread	Part # Left Thread	Bolt Dia (A)	Width (B)	Thread (C)	Thread Length (D)	Suggested Applications
15730	15731	10mm - 3/8"	2.000"	3/4" - 16	3.2"	Aftermarket Jeep TJ upper control arms
15732	15733	12mm	2.000"	3/4" - 16	3.2"	Aftermarket Jeep JK front upper control arms
15734	15735	14mm - 9/16"	2.375"	3/4" - 16	3.2"	Aftermarket Jeep JK rear upper control arms
15736	15737	16mm - 5/8"	2.625"	1" - 14	3.2"	Aftermarket Jeep TJ and JK lower control arms modified for 5/8"-16mm bracket bolts
15738	15739	16mm - 5/8"	2.625"	1 1/4" - 12	3.2"	Heavy duty aftermarket Jeep TJ and JK lower control arms modified for 5/8"-16mm bracket bolts
15740	15741	14mm - 9/16"	2.625"	1" - 14	3.2"	Aftermarket Jeep TJ and JK lower control arms
15742	15743	14mm - 9/16"	2.625"	1 1/4" - 12	3.2"	TJ and JK lower control arms

Part # Right Thread	Part # Left Thread	Bolt Dia (A)	Width (B)	Thread (C)	Thread Length (D)
15744	15745	3/8"	1.5"	1/2" - 20	2.9"
15746	15747	1/2"	2.0"	3/4" - 16	3.0"
15748	15749	16mm 5/8"	2.5"	1 1/4" - 12	2.8"
15750	15751	3/4"	3.250"	1 1/4" - 12	3.2"
15752	15753	12mm	40mm	3/4" - 16	2.9"
15754	15755	12mm	40mm	M18x1.5	2.9"
15764	15765	12mm	45mm	3/4" - 16	2.9"
15766	15767	12mm	45mm	M18x1.5	2.9"
15768	15769	12mm	47mm	3/4" - 16	2.9"
15770	15771	12mm	47mm	M18x1.5	2.9"
15772	15773	12mm	50mm	3/4" - 16	2.9"
15774	15775	12mm	50mm	M18x1.5	2.9"
15780	15781	12mm	57mm	3/4" - 16	2.9"
15782	15783	12mm	57mm	M18x1.5	2.9"
15784	15785	14mm	40mm	3/4" - 16	2.9"
15786	15787	14mm	40mm	M18x1.5	2.9"
15792	15793	12mm	44.5mm	3/4" - 16	2.9"
15794	15795	12mm	44.5mm	M18x1.5	2.9"

Builder Ball Joints

SPC Builder Ball Joints provide an excellent alternative to traditional spherical bearings or OE ball joints when constructing custom control arms. Designed with the professional/home fabricator in mind, these rebuildable and greaseable ball joints offer high load capacity combined with massive articulation. Derived from SPC's latest generation of large truck ball joints, the Builder Ball Joint Series features a wear-compensating design with redundant sealing for years of service between rebuilds. Hardened, alloy steel ball studs are offered for a variety of applications, making it easy to incorporate these joints into your project.

Aluminum Cap and Rubber O-Rings provide redundant sealing keeping ball joint free of contaminants

Rebuildable and Greaseable for years of service, even under the harshest conditions

2-Piece Hybrid Race compensates for wear while providing high load capacity

Large Diameter Ball provides maximum bearing surface and massive articulation

Alloy Steel Stud Application-specific hardened alloy steel studs for maximum strength

High-angle Boot (not shown) keeps out dirt and water, even at extreme articulation



15201 Rebuild Kit

Includes: Races, spring, O-rings, boot, boot retainer and cotter pins.

72120 - Spanner Wrench, pg 169

Part No.	Make	Model
15211	Toyota Nissan Ford	Tacoma, 4-Runner, Tundra, Sequoia Frontier, Pathfinder, Xterra, Equator T6Ranger
15212	Toyota Lexus	Landcruiser 100/200 Series, FJ Cruiser, 4-Runner, Tundra, Sequoia LX470, LX570, GX
15213	Chevy/GMC Ram	1500 HD, 2500, 3500, Avalanche 2500, Suburban 2500, H2 1500 (Except Mega Cab)
15214	Jeep	Commander, Grand Cherokee (WK)
15215	Ford	F-150
15216	Isuzu	D-Max
15217	Chevy/GMC	Colorado, Canyon

Builders Tubular Chassis Components

ROD END RECEIVERS

Material Spec: 4140 N Chromoly Steel

Includes Grade 8 bolt, metal locknut and 2 AN washers

Welds into stock tubing sizes. Pinch bolt maintains high clamping force.



ROUND ROD END RECEIVERS

RH Thread Part #	15120	15110	15100	15090	15080	15092	15082
LH Thread Part #	15125	15115	15105	15095	15085	15097	15087
Thread Size (A)	1/2" - 20	5/8" - 18	3/4" - 16	7/8" - 14	1 1/4" - 12	7/8" - 14	1 1/4" - 12
Outside Dia. (B)	.745"	.870"	1.120"	1.370"	1.870"	1.260"	1.760"
Thread Length (C)	1.2"	1.3"	1.4"	1.5"	1.7"	1.5"	1.7"
Overall Length (D)	1.813"	1.938"	2.125"	2.250"	2.563"	2.250"	2.563"
Nominal Tube Size	.875" OD	1.000" OD	1.250" OD	1.500" OD	2.000" OD	1.500" OD	2.000" OD
Recommended Tube Wall Thickness	0.065"*	0.065"*	0.065"*	0.065"*	0.065"*	0.120"**	0.120"**

* .065 receivers may be turned down to fit other tubing sizes ** We recommend that .120 receivers not be turned down

SQUARE ROD END RECEIVERS

RH Thread Part #	15170	15160	15150	15140	15130
LH Thread Part #	N/A	N/A	N/A	N/A	N/A
Thread Size (A)	1/2" - 20	5/8" - 18	3/4" - 16	7/8" - 14	1 1/4" - 12
Width (B)	0.688"	0.875"	1.063"	1.250"	1.813"
Thread Length (C)	1.2"	1.3"	1.4"	1.5"	1.7"
Overall Length (D)	1.813"	1.938"	2.125"	2.250"	2.563"

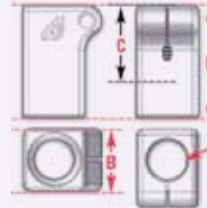

WELD IN BUNG RECEIVERS

RH Thread Part #	15300	15302	15304	15306	15308
LH Thread Part #	15301	15303	15305	15307	15309
Thread Size	1/2" - 20	3/4" - 16	1" - 14	1 1/4" - 12	M18 x 1.5
Tube ID (A)	0.75"	1.00"	1.50"	1.75"	1.00"
Width (B)	1.00"	1.25"	1.75"	2.00"	1.25"
Overall Length (C)	.75"	1.125"	1.50"	1.875"	1.060"

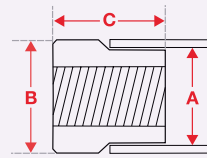

SPHERICAL BEARING RECEIVERS

Material Spec: 4140 N Chromoly Steel Includes Retaining Ring

Part #	15065	15060	15055	15050	15045	15040	15042
Bearing Dia. (A)	0.8125"	1.0000"	1.1875"	1.3750"	1.6250"	2.1250"	2.7500"
Bear. Race Width (B)	0.4060"	0.5050"	0.5670"	0.6300"	0.7550"	1.0050"	1.099"
Receiver OD (C)	1.063"	1.250"	1.483"	1.625"	1.925"	2.500"	3.250"
Receiver Height (D)	0.58"	0.71"	0.84"	0.92"	1.06"	1.41"	1.527"
Bearing Offset (E)	0.0170"	0.0125"	0.0265"	0.0150"	0.0025"	0.0025"	0.012"

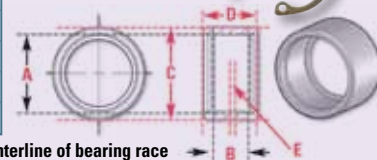

E - Centerline of receiver to centerline of bearing race

HIGH MIS-ALIGNMENT INSERTS (Pair)

Material Spec: Hardened Stainless Steel

Part #	15032	15028	15015	15020	15018	15010	15012	15024	15022
Shoulder OD (A)	0.500"	0.625"	0.750"	0.875"	0.875"	1.000"	1.000"	1.500"	1.500"
Internal Dia. (B)	0.375"	0.500"	0.500"	0.500"	0.625"	0.625"	0.750"	0.625"	0.750"
Shoulder Length (C)	0.300"	0.345"	0.433"	0.433"	0.385"	0.675"	0.675"	0.608"	0.683"
Part Length (D)	0.730"	0.720"	0.875"	0.875"	0.950"	1.080"	1.080"	1.790"	1.790"
Stack Length (E)	1.500"	1.500"	1.750"	1.750"	2.000"	2.160"	2.185"	3.600"	3.6250"
Mis-Alignment Angle	21 Deg.	24 Deg.	30 Deg.	30 Deg.	30 Deg.	30 Deg.	28 Deg.	29 Deg.	30 Deg.

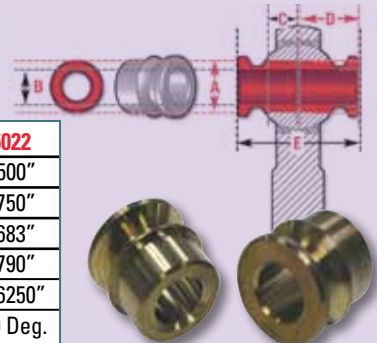

Applications

Alignment Parts

Heavy Duty

OE Replacement

Racing/Builders

Tools

Brake and CV

Gear/Index

Part #	Dia.	Part #	Dia
15835	.75"	15865	2.5"
15840	1.0"	15870	3.0"
15850	1.5"	15875	3.5"
15860	2.0"	15880	4.0"

Set #	Dies Included
15810	15835, 15840, 15850, 15860, 15865
15815	15870, 15875, 15880

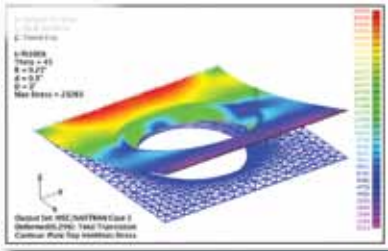

FLARED HOLE DIES

15810

15815

Often called "dimple dies," flared hole dies are used in sheet-metal fabrications to provide rigidity and strength to flat panels. Due to the resulting high strength-to-weight ratio flared holes are found in many aircraft and race vehicle designs.

Beginning with comprehensive finite element analysis supported by extensive prototype testing, our light weight Flared Hole Dies are engineered to provide the optimum combination of performance attributes:

- Eliminate edge tearing when used on chromoly, even with edges hardened by laser cutting methods
- Will flare holes in chromoly up to .090" thick or flare holes in up to .125" mild steel
- Manufactured from high quality hardened tool steel
- Available for hole diameters from 3/4" to 4"



FASTRAX™ CAMBER / CASTER GAUGE

Portable, hands-free alignment can be done quickly and easily with the **FasTrax™ Adjustable Camber/Caster Gauge**. This tool will help you fine tune your alignment for optimal tracking and handling while minimizing alignment headaches.

- Includes gauge and wheel mount.
- Saves time and tires.
- Displays Camber ±4° / Caster -4° to +12°.
- Accurate, rugged and easy-to-use.

91000 Standard - Fits wheels 13" to 17"
Optional Toe Adapter Kit (91100) sold below.

91010 Performance - Fits wheels 17" to 22"
Optional Toe Adapter Kit (91100) sold below.

91025 Off-Road - Fits Wheels 13" to 17" **91025**
 Align off-road wheels - tire sizes up to 44".
 Includes longer toe arms, bungee cord & tape measure.

91030 No Lip Adapter
 A quick adapter to attach the FasTrax to wheels without an outer "lip". Fits on the 91000, 91010 and 91025.

91100 Optional Toe Adapter Kit
 Simply lower the toe arms and insert tape measure into slot. Then measure to opposite tire reference point for accurate and fast toe readings. Includes 2 arms and reinforcement blocks that install easily onto either the 91000 or the 91010.



See page 176 for more on our Popular FasTrax™

87910



ALIGNMENT TOOL BOARD

This board set gives technicians the tools needed to complete today's modern alignments quickly and efficiently. Contains our most popular tools, with a handy plastic peg storage board to keep all your alignment tools in one easy to reference location.

BOARD INCLUDES ONE EACH OF THE FOLLOWING:

Tool Number	Page	Description
8370	163	Tie Rod Puller
37985	164	4-Way Ball Joint/Tie Rod Separator
40840	165	Tie Rod Adjusting Wrench Set (4) 10.5-12mm rods, 12-14mm rods 14-16mm rods, 16-19 mm rods
45938	167	Colorado/Canyon 4WD Alignment Socket
45940	167	GM Express Van Tool
74910	170	Cam Knock Out Punch
77350	171	Heavy Duty Tie Rod Tools
77880	171	Ford OE Sleeve Puller
81139	172	Magnetic Adj. Camber Gauge
83775	172	Cas/Cam Tool - 93 & Up F-Body
85127	173	3/8" Carbide Rotary File
85137	173	3/8" Rotary File for Aluminum
87560	174	Honda 24mm Toe Tool
99918	175	Wheel Spreader Bar - A must for Mercedes

27



PITMAN ARM SEPARATOR

For use on most cars and some light trucks. The tapered wedge easily removes the pitman arm from the shaft with just a few sharp hammer blows.

DIMENSIONS: 1" opening, 12" overall length.

Slide Hammers/Pullers

498



FRONT HUB AND AXLE PULLER

498 removes front hubs on vehicles with independent front suspensions. Remove screw and use it with 499 axle puller to remove axles in compact cars.

498

APPLICATIONS

Compact cars

SET INCLUDES

- 498-1 Yoke
- 498-2 Center screw
- 498-3 Jam nut

499

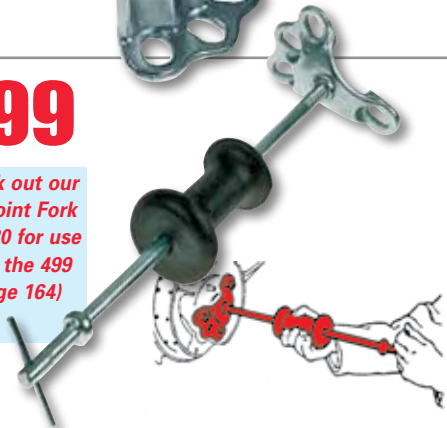

FLANGE TYPE AXLE PULLER

Flange Type Axle Puller can be used as a regular wheel puller or hub puller, as well as a flange type puller. The bolt circle range is from 4-1/2" to 5-1/2", which covers all cars and small trucks with flange type axles. The four slots allow this tool to be used on 4, 5, or 6 stud designs.

499

APPLICATIONS

All cars and small trucks with flange type axles

SET INCLUDES

- 499-1 Yoke
- 499-2 Center rod assembly
- 499-3 Jam nut
- 499-4 Hammer

Check out our CV Joint Fork #38620 for use with the 499 (page 164)

Applications

Alignment Parts

Heavy Duty

OE Replacement

Racing/Builders

Tools

Brake and CV

Gear/Index

CAUTION: Not for use with impact wrenches (air tools).

SPANNER WRENCH

Thin walled spanner wrench designed specifically for installation and removal of OE and **23000** (page 74) screw in 4WD alignment sleeves.



4169

APPLICATIONS

Dodge RWD:
1987 - 04 Dakota
1998 - 03 Durango

DODGE CAMBER TOOL

This wrench is specifically designed to access the hard to reach upper control arm bolts used to adjust caster/ camber on RWD Dodge Durangos and Dakotas.



6140

APPLICATIONS

Most compact/standard passenger cars and light trucks

TIE ROD TOOL

Four position feature and 360° rotation lets you grip the sleeve properly, even with limited access. Fits most passenger cars and light trucks.



7023

CHRYSLER/FORD CAMBER/CASTER TOOL

An excellent tool for fast camber-caster changes on most older Chrysler and Ford products w/SLA style suspensions.



8286

83707 Center Screw with Tip

CAUTION: Not for use with impact wrenches (air tools)

5" TIE ROD PULLER

Removes tie rod ends with a straight, fast, firm push. Makes installation of the **87330** camber/toe kit easier (pg. 123). It has a 2-1/4" reach and a 2-1/2" spread. Also for pressing bushings.



8370



HOSE CUTTER

This high quality hose cutter provides a straight, even, clean cut on heater, air conditioning, braided rubber or plastic hose up to 1-1/8" diameter.

CUTS

- Any Plastic/Rubber Hose Up To 1-1/8" Outside Diameter
- Heater Hose
- Side Body Molding
- Windshield Channeling
- Non-Metal Air Brake Hose
- Fuel Line Hose
- Copper Wiring
- Heater Hose
- And More

10011 - REPLACEMENT BLADES 2 per pkg



10010

BUSHING PRESS SLEEVES

The sleeves are designed to match the angle of the yoke on the axle housing to insure proper installation. Use with the **72509** Ball Joint Press (page 165).

23580 - To be used with our Dodge, Jeep and Ram Pin Joints (part nos. **23510, 23520, 23530, 23540** page 78).

23780 - For our Dodge/Ram Truck Pin Joints (part nos. **23710 - 23730** page 71 and **23800 - 23830** page 78).



23580

23780

WHEEL WEIGHT TOOL

The best tool for removing or installing passenger car and light truck wheel weights. Incorporates hooks for removal of wheel weights on many different types of wheels. Not for use on aluminum or decorative wheels.



37000

Removing or installing wheel weights on OTR Trucks? Check out Part #83125 (pg. 172)

Applications
Alignment Parts
Heavy Duty
OE Replacement
Racing/Builders
Tools
Brake and CV
Gear/Index

Tools

37980



STEERING KNUCKLE TOOL

Stop damaging steering knuckles by removing linkages or struts with pry bars, screwdrivers and hammers. Use the Steering Knuckle Spreader Tool to make quick work of tight and corroded steering knuckles by simply turning the threaded wedge assembly. This is a must for any technician performing suspension work, especially for those who see the Ford Taurus or BMW passenger cars. Blow molded case included.

37985

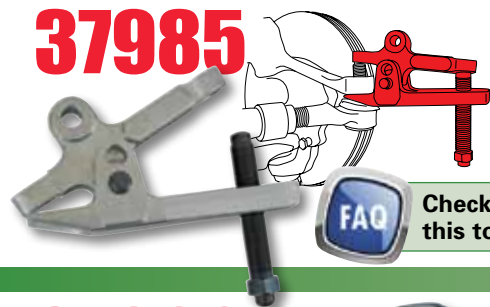

4-WAY BALL JOINT/TIE ROD SEPARATOR

This is the highest strength and most versatile ball joint removal tool on the market. The unique design of the forged 4-Way Ball Joint Separator allows the tool to be adjusted to remove ball joints of various heights, doing jobs that previously required multiple tools. Affordable, strong, and easy to use.

Check out online how to use this tool to remove wheel studs

37990



BALL JOINT SEPARATOR

This heavy duty, drop forged alloy steel, lever-type ball joint and tie rod end remover provides good leverage action to remove stubborn tie rod ends or break ball joint tapers easily. Use when space prevents use of a direct action separator. The 37990 fits 3/4" openings.

37995

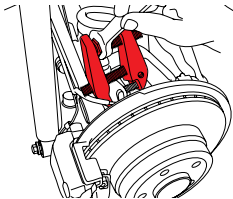

MASTER BALL JOINT SEPARATOR SET

This master ball joint separator set from SPC is a must for any technician replacing ball joints, control arms, or tie rod ends on today's cars and SUVs. With four different opening sizes (24mm, 27mm, 31mm, and 36mm) a threaded height adjuster and two different sized forcing screws, this seven piece set is the most versatile on the market. From a Jeep tie rod end to a BMW X5 rear upper control arm, this set will have you covered. Packaged in a convenient blow molded case to help you keep track of your stuff.

38620



CV JOINT FORK

When used with 499 (page 162), this tool will pull most CV joints that use a hidden snap ring to hold them in the transaxle. Made to remove the axle assembly without damaging the transmission case or inside roller bearing.

For threaded rod - 5/8" x 18

40250



INTERNAL COIL SPRING COMPRESSOR

A handy chromoly steel compressor designed to fit inside most coil springs with an internally mounted shock. Will accommodate spring lengths from 8-1/4" to 14". It can be used on any coil spring with a minimum inside diameter of 3-3/8" to a maximum inside diameter of 5-5/8" and wire diameters up to 3/4". **Note: NOT for use on MacPherson struts or Fiat vehicles.**

40260

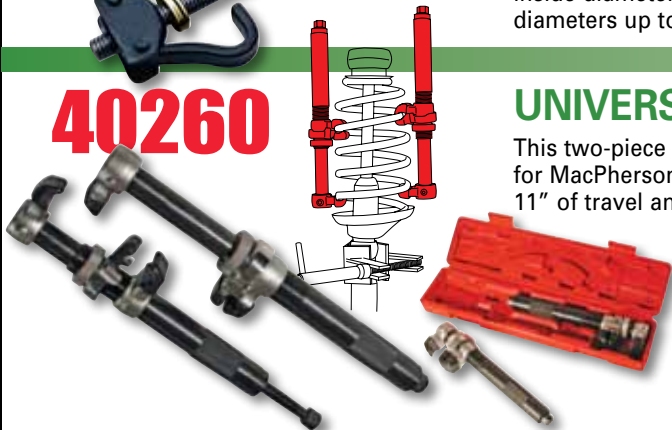

UNIVERSAL SPRING COMPRESSOR

This two-piece internally threaded spring compressor is a great option for MacPherson strut, coilover, and other accessible springs. With 1" to 11" of travel and a 2,700 lb per pair max working load, this is an ideal tool for almost any spring. Vinyl coated ends protect the spring from damage, safety jaws keep the compressor stabilized on the spring, and the ball bearing load surface makes compression easy using simple hand tools. Use of both hooks per spring is required.

Applications

Alignment Parts

Heavy Duty

OE Replacement

Racing/Builders

Tools

Brake and CV

Gear/Index

VALVE STEM PULLER

This easy to use valve stem puller protects the wheel and rim while you get the job done quickly. Simply screw the pivoting head onto the valve stem, slide the hard rubber protecting block to the edge of the wheel rim and remove the stem without rim scrapes or damage! Also works on 2 piece TPMS.

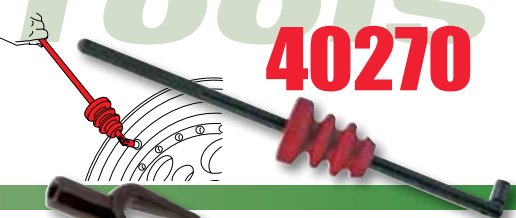

40270

TIE ROD/BALL JOINT/PITMAN ARM TOOL

Five tools in one, this handy kit consists of three drop forged forks and two handles. One handle is for use with a hammer and one is designed to fit an air hammer. All forks are threaded to interchange with either handle. Comes with 3 forks of 11/16", 15/16" and 1-1/8" openings.



40310

TIE ROD ADJUSTING WRENCH SET (4)

Every alignment tech needs this tie rod wrench set in their tool box. Adjust inner tie rods with this easy to use 4 piece wrench set. The wrenches feature spring loaded toothed jaws and sturdy grips to make toe adjustments quick and easy. This set of wrenches fits tie rods from 10.5 to 19mm. **Individual tools are also available:**
40850 fits 10.5-12mm rods **40860** fits 12-14mm rods **40870** fits 14-16mm rods **40880** fits 16-19 mm rods



40840

UNIVERSAL TIE ROD ADJUSTING TOOL

This economical tool fits most cars and light trucks with split tie rod sleeves. Double-end feature makes 360 degree turns possible.



40900

Service Sets

UPPER CONTROL ARM BUSHING 40910

Easily replace press-in type control arm bushings on many domestic and imported vehicles with this service set. Mechanical power screw quickly and easily removes worn bushings and installs them without damaging the control arm. Set includes C-Frame, screw assembly and all adapters to do the job quickly and correctly. **Packaged in a durable plastic case.**

INCLUDES (See below right):

4427(3), 4428, 4429, 4430, 4431, 4432, 4433, 4434

TOYOTA CAM EXTRACTOR 40915

Use this press tool to remove stuck OE cam sleeves from Toyota trucks. The extended length forcing screw allows you to remove the sleeve without removing the steering rack. Recommend when installing our 25425, 25430, 25435, 25440, 25445 and 25450 replacement Toyota cams (page 80).

INCLUDES (See below right): 4434, 44339

PERFORMANCE BALL JOINT PRESS 40920

This tool was specifically designed to remove the original equipment ball joints on smaller cars when installing SPC Performance's sliding ball joints (pages 83 & 86). With this revolutionary design you can remove the ball joint from the front upper control arm without removing the arm from the vehicle, saving time and costs. **Packaged in a convenient blow-molded plastic case** this set comes complete with adapters for removing and installing stock or Specialty Product's sliding ball joints.

INCLUDES (See right): 4433, 4434, 40923, 40925, 40927



- 4427** U-Adapter
- 4428** 1/16" Thick Tube
- 4429** 1/18" Thick Tube
- 4430** 3/16" Thick Tube
- 4431** Forcing Head
- 4432** Receiving Socket
- 4433** Forcing Screw
- 4434** C-Frame
- 40923** Adapter
- 4435** Forcing Screw Cap
- 40925** Adapter
- 40927** Adapter
- 40929** C-Frame and Forcing Screw
- 44339** Sleeve Extracting Screw
- 40915** Toyota Cam Extractor
- 4432** Adapter
- 4431** Adapter
- 4434** Adapter
- 4433** Adapter
- 44339** Adapter
- 4428** Adapter
- 4429** Adapter
- 4430** Adapter
- 4427** Adapter
- Cap 4435**

40940

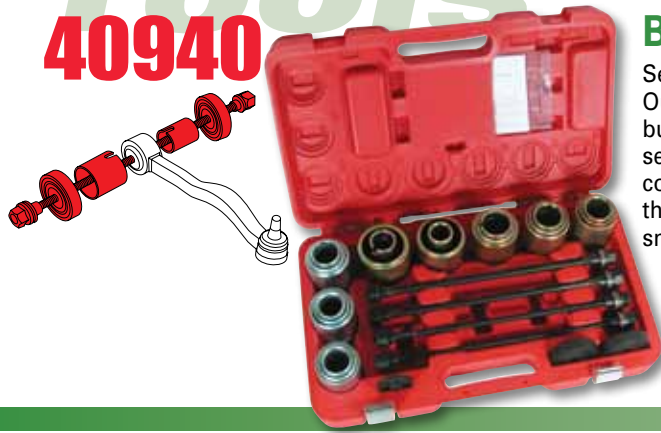

BUSHING PRESS SET (29 PIECE)

Service a wide range of bushings with this versatile press set. Our 29 piece kit will allow you to efficiently remove and install bushings from 1-1/2" to 3" OD (36 - 80mm). Save time by servicing the suspension bushing on the vehicle vs. removing components to use a shop press. The kit uses long ACME threaded screws and bearing nuts to make manual pressing a snap.

SET INCLUDES:

- 4 - ACME Threaded Spindles
M10 x P 1.5, M12 x P 2.0,
M14 x P 2.0, M15 x P2.50

3 - Plate adapters

- 22 - 95mm Long Sleeves
Ranging in size from
34mm ID to 80mm ID

41000



DELUXE WHEEL LOCK REMOVAL SET

This set safely removes and replaces GM, Ford and Chrysler wire wheel hubcap locks on 1978 and up vehicles. Variable drive keys will also fit Corvette, McGard hubcap locks and aftermarket wheel lug locks. Kit comes in a durable plastic carrying case with complete instructions. Replacement parts available.

Wear appropriate eye protection when using this tool.

SET INCLUDES:

- 40008 Punch
- 40010 Ford and Chrysler lock cylinder
- 40020 GM spline hubcap locks & triangular hubcap lock
- 40030 GM hubcap locks
- 40045 Stripped 18mm lugnuts/Corvette, GM N&F body wheels
- 40065 Standard McGard wheel locks/ Oversized McGard wheel locks
- 40090 Large Diameter Chrysler Lock
- 40093 Socket installing driver
- 40095 Quick-Off Lugnut Removal Tool

BONUS!

THIS WHEEL LOCK REMOVAL SET INCLUDES A DUAL SIDED LUGNUT REMOVAL TOOL THAT REMOVES DAMAGED OR ROUNDED O.E. STYLE LUGNUTS.

41030



TIE ROD TOOL

This 1/2" drive tie rod tool will allow the easy removal of tie rod ends on most cars and light trucks. The U-shaped slot measures 1" x 3/4".

CAUTION: Not for use with impact wrenches (air tools).

41110



MASTER BALL JOINT ADAPTER SET

Expand the service capability of your ball joint press with this Master Ball Joint Adapter Set. This complete kit includes the adapters and receiving tubes needed to work on GM, Ford and Dodge two and four wheel drive trucks, vans and SUVs. Kit also includes a live center forcing screw for heavy duty applications.

REPLACEMENT PARTS AVAILABLE:

RECEIVING TUBES:

- 4159 2.87 OD x 2.62 ID
- 4415 2.50 OD x 2.25 ID
- 4416 2.0 OD x 1.75 ID
- 4417 2.5 OD x 2.25 ID
- 4418 2.13 OD x 1.80 ID
- 4419 2.5 OD x 2.25 ID x .75 AL
- 4420 2.5 OD x 2.25 ID x 2.75 AL
- 4421 3.0 OD x 2.75 ID
- 4422 2.75 OD x 2.43 ID
- 4423 2.50 OD x 2.20 ID
- 4424 REMOVER/INSTALLER - 1.50 OD x .82 ID
- 4425 INSTALLING TUBE - 2.0 OD x 1.82 ID
- 4426 RECEIVING CUP - 2.12 OD x 1.75 ID

APPLICATIONS

- Buick:** 2013 & Up XTS
Cadillac: 2010 & Up LaCrosse
 2011 & Up Regal
Chevrolet 4WD: 2004 - 12 Colorado
GMC 4WD: 2004 - 12 Canyon
Isuzu 4WD: 2006 - 06 i-350
 2007 - 08 i-370

CAUTION: Not for use with impact wrenches (air tools).

GM CAM BOLT SOCKET

45938

Many GM trucks and cars can be difficult to align because it is impossible to access the head of the cam bolt to adjust. This 3/8" drive socket fits over the end of the bolt allowing the technician to turn the alignment cams to change alignment angles after loosening the lock nut.



APPLICATIONS

- Cadillac RWD/4WD:** 2002 & Up Escalade
Chevrolet/GMC RWD/4WD:
 1999 & Up 1500 & HD Crew Cab
 1999 - 10 2500, 3500
 2002 - 13 Avalanche 1500, 2500
 2004 - 12 Canyon & Colorado
 2003 - Up Express/Savana Van
 2000 & Up Suburban, Tahoe, Yukon,
 Yukon XL (1500, 2500)
Hummer AWD: 2002 - 09 H2
 2006 - 10 H3, H3T

GM TRUCK/VAN CAM ADJUSTING TOOL

45940

This wrench makes it easy to adjust the upper control arm cams on Chevrolet Express and GMC Savana vans. The tool surrounds the entire perimeter of each cam to provide a solid no-slip means to move the hard-to-reach and often rusty OEM cams.



APPLICATIONS

- Chevrolet/GMC RWD/4WD:**
 2011 & Up 2500/3500
 2015 & Up Canyon
 2015 & Up Colorado

GM HEAVY DUTY TRUCK TOOL

45945

This wrench makes it easy to adjust the control arm cams on many modern GM and Chevy HD Trucks along with the new Colorado and Canyon. The tool surrounds the entire perimeter of each cam to provide a solid no slip means to reach the hard-to-reach and often rusty OE cams.



APPLICATIONS

- Chrysler:** 1993 - 97 Concorde
 1994 - 97 LHS, New Yorker
Dodge: 1993 - 97 Intrepid
Eagle: 1993 - 97 Vision

LH TOE TOOL

55600

This tool kit includes three tools which allow easy access and provides a much easier method for the technician to adjust toe on popular Chrysler LH body vehicles such as the Concord, New Yorker, and Intrepid.



APPLICATIONS

- Chrysler:** 1998 - 01 LHS
 1999 - 04 300M, Concorde
Dodge: 1998 - 04 Intrepid
57720 Replacement insert Kit (includes 2 inserts)
Use 23600 replacement sleeve if the sleeve is damaged (page 77).

LH TOE TOOL

55700

The LH vehicles use a knurled sleeve with a slot in it, threaded to the outer tie rod and inner tie rod to adjust toe. Often the sleeve is hard to turn because of corrosion on the threads. Conventional toe-adjusting tools can damage the original sleeve. This tool will help prevent damage to the sleeves and inner bushings while making adjusting the toe easier and quicker.



SPC encourages new product requests, new application suggestions, and other ideas that techs and installers may have to improve and expand our product line. The GMC Express Van Tool (above) is one of our tech's ideas brought to market. Your idea could be the next best thing.



64225



MAGNETIC ANGLE GAUGE

This angle gauge is an easy, accurate way for measuring frame and drive shaft angles. An ideal tool to ensure the drive line angle is still within specification for raised and lowered vehicles.

Alignment equipment manufacturers are using frame angle input with their software for completing Caster specifications.



Check out SPC's other gauges
FasTrax™ Camber/Caster Gauge (page 176)
and Universal Radial Run-Out Gauge (page 179)



65100

HONDA BUSHING EXTRACTOR

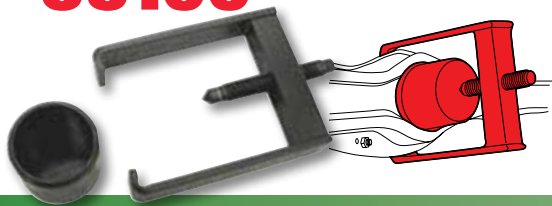

Easily and quickly remove and install rear trailing arm bushing in as little as 15 minutes per side vs. the factory "book" time of 1.8 hours per side. No need to remove the trailing arm from the vehicle or use a hydraulic press.

APPLICATIONS

Acura: 1994 - 01 Integra

Honda:

1988 - 00 Civic

1988 - 92 CRX

1992 - 97 Del Sol

66025



CHRYSLER BUSHING PRESS SLEEVES

These adapter sleeves are designed to be used with the **40920** Performance Ball Joint Press (page 165). It is designed specifically to remove the stock rear control arm bushings and to install our Offset Rear Camber Bushings, Part No. **66050** (page 86) used on the newer Chrysler LX platform cars.

67647



SUBARU/SCION TOE PRESS ADAPTER

The OE rear toe link bushing on many Subarus and the Scion FR-S can be easily removed when using the 67647 Bushing Press Adapter. Our Eccentric Toe Bushings (part #**67660** page 100) can then be installed using the adapter and a **72509** Ball Joint Press (pg 169), **40920** Performance Ball Joint Press (pg 165), or equivalent.

68670

REMOVABLE CUTTER ROTOR-BOR



Air drill driven tool made to cut out the spot welds holding the original equipment alignment plate to the top of strut towers. Once the plate is loosened caster and camber can be adjusted. Sold with 3/8" and 5/16" removable cutters. Use our "Cool Tool" cutting fluid, **85774** (page 173), for longer cutter life.



68750

Replacement cutters (3) - 3/8"

68780

Replacement cutters (3)- 5/16"

CAUTION: Always wear safety glasses when using cutting or grinding tools and equipment.

68880

68890



CHRYSLER SOCKETS

These sockets are used on Chrysler products with screw in ball joints. They have a 3/4" square drive and are four-point, a perfect fit for our ball joints on page 157.

APPLICATIONS

68880 - 1-29/32" opening for Plymouth/Dodge

68890 - 2-9/64" opening for Chrysler

69330



HONDA CLEARANCE ARM SOCKET

This special 10 point socket is needed when removing the OE rear lower control arm on 2001 to 2005 Honda Civics, 2003 to 2011 Elements, 2002 to 2006 CRVs and 2002 to 2006 Acura RSXs. Included with Part No. **69300** and **69400** (page 102).

Applications

Alignment Parts

Heavy Duty

OE Replacement

Racing/Builders

Tools

Brake and CV

Gear/Index

71909 SET INCLUDES:

71959, 71969, 71979, 71989, 71999

71959

3/4" opening for compact cars

71969

7/8" opening for standard cars

71979

1-1/8" opening for light trucks

71989

1-7/16" opening for adjusting the center link sleeve on Ford Super Duty Trucks

71999

1-13/16" opening to adjust the drag link sleeve on Ford Super Duty Trucks

CAUTION: Not for use with impact wrenches (air tools).

71909 TIE ROD TOOL KIT

This kit includes part numbers 71959 through 71999. It will allow adjustment of most cars and light trucks and also includes the two larger adjusting tools needed for the new Ford Super Duty pickups. Tools have a 1/2" drive opening that allows the use of a ratchet or breaker bar. Kit comes with a protective carrying case.

71959, 71969, 71979 TIE ROD TOOLS

These tie rod tools spread the tie rod adjusting sleeve for easier adjustment. You can use these tools with a breaker bar for additional power. With 1/2" drives.

71989, 71999 FORD SUPER DUTY TOOLS

These are the tools needed to adjust toe on the new Ford Super Duty Pickups. With 1/2" drives.



APPLICATIONS

BMW: SPC Part #72065, #72070, #72080, #72090, #72180, #72190

Mini Cooper: #67620, #67630

FRONT STRUT TOOL

This tool was designed for turning the valves on adjustable damping struts when our SPC Adjustable Strut Mounts are used on BMWs (pg. 107 & 108) and Mini Coopers (pg. 99).



APPLICATIONS

Porsche: Adjustable Arms Part No. 72610 pg. 113

Muscle Car: Adjustable Arms Part Nos. 97110, 97120, 97130, 97140 pg. 138
Part Nos. 97150, 97160, 97170, 971780, 97190, 97260, 97300 pg. 140

Builder Ball Joints: pg. 159

SPANNER WRENCH 3/8" DRIVE

This tool is a must when servicing rebuildable ball joints from SPC. The 30mm spanner wrench has 5mm pins and is specifically designed for SPC's Porsche arms, GM Muscle Car arms and Builder Series ball joints. Featuring a 3/8" square drive to make removing the ball joint retainer cap fast and easy, use this tool in conjunction with a torque wrench to set ball joint preload and stud turning torque to where you want it or on any project that uses this size spanner.



4438

4437

29503

29504

29505

38355

305228

305227

204508

38354

RWD/4WD BALL JOINT PRESS

Remove and replace ball joints without "brute force" methods that can cause costly damage. Now you can take on 4WD ball joint service in addition to servicing most cars. A forcing screw-powered press, used with proper adapters, easily removes and installs all press-fit ball joints (inc. GM plastic pin "U" type joints). In a durable plastic case.

PACKAGE INCLUDES:

- 4437** Press
- 4438** Forcing Screw
- 29503** Receiver Tube, 3" OD x 2-3/4" ID
- 29504** Receiver Tube, 2-1/2" OD x 2-1/4" ID
- 29505** Receiver Tube, 2" OD x 1-3/4" ID
- 38354** 4WD Receiving Cup
- 38355** Installing Cup
- 204508** 4WD Installing Adapter
- 305227** Installing Adapter
- 305228** Removing Adapter

72509



73010



1-1/8" PUNCH

This tool is used to cut holes necessary to install our **83115** (page 124) camber kits. A must to ensure a good, round hole.

NOTE: Lubricate before use.

CAUTION: Not for use with impact wrenches (air tools).

73119



PITMAN ARM PULLER

Designed to handle the toughest job, the **73119** is adjustable and has special forged jaws shaped to fit the job. Positive grip allows this tool to do many other pulling jobs.

CAUTION: Not for use with impact wrenches (air tools).

74400 74500 74600

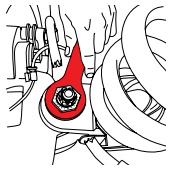

ADJ. SLEEVE WRENCHES

These wrenches make presetting our adjustable truck sleeves (page 79) easier for the installer. When using the **74400** wrench it is recommended that the opening be equally positioned over the slot opening of the sleeve body.

74400 1-1/2" Open End

For **24160** - Holds outer bushing body and for **24180** - Holds inner eccentric sleeve.

72370 -- Holds outer eccentric sleeve.

74500 1-1/4" Box End

For **24120**, **24130**, **24180** - Adjusts the inner sleeve.

74600 Double Box End

For **24220**, **24230** - Adjusts the inner sleeve.

74910

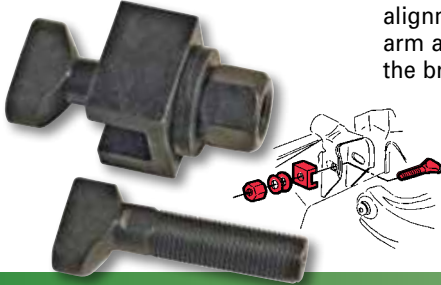

KNOCK OUT PUNCH

A necessary tool for removing the alignment inserts on the upper control arm alignment brackets without damaging the bracket. Includes a center punch for the older GM vehicles and newer Jeep JKs and an offset punch for GM's newer models.

74914 - Replacement Offset Punch.

74915 - Replacement Center Punch.

APPLICATIONS

Cadillac RWD/4WD: 1999 - 01 Escalade

Chevrolet/GM RWD/4WD:

1988 - 00 1500, 2500, 3500

1992 - 94 Blazer (Full Size)

1996 - 02 Express & Savana Van

1988 - 91 Jimmy (Full Size)

1992 - 99 Suburban; 1995 - 99 Tahoe

1992 - 99 Yukon

Chevrolet/GM AWD:

1990 - 01 Astro & Safari Van

Jeep RWD/4WD: 2007 - 18 Wrangler (JK)

74920 74930 74940

PUNCH TOOLS

Use an SPC slot punch to elongate a hole and get the change you need. Whether the OE left you an upset that won't break out, didn't give you a large enough slot, or didn't give you a slot at all, use this high quality tool to quickly and easily punch one. Made on the USA with tight tolerances and high quality bearings these punches are built to last.

74920

14mm bolt / ±8mm offset

74930

12mm bolt / ±7mm offset

74940

12mm bolt / ±4mm offset

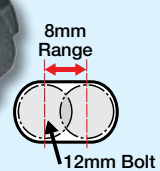
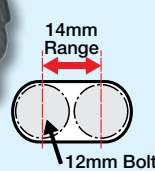
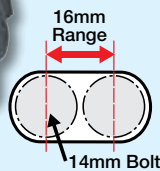

75915



EZ SHIM™ CUTTER

This cutter, a must for properly cutting our EZ Shims™ (page 116), is a great tool for a variety of cutting needs. Its thin cutting blades help prevent breakage and waste.

HONDA ADAPTERS

Honda Adapter #75980 is used in conjunction with the 72509 Ball Joint Press (page 169) and are used with the 67465 Honda Civic Camber Kit on page 94. You need these adapters to push the old bushing out of the stock arm and also to install the new bushing included in the 67465 Kit.



75980

MERCEDES PRESS SETS

These Mercedes Rear Bushing Press Adapter Sets are designed for quick, easy removal of the OE rear control arm bushings and for the insertion of SPC's new adjustable camber bushings. These tool sets are a must for any shop servicing Mercedes vehicles.

75990 - For **28840** (page 83) includes adjusting wrench

76000 - For **28850, 28855 and 28860** (page 83)



75990
76000

TORQUE LIMITING IMPACT EXT. SET

This convenient 8 piece Torque Limiting Extension And Protective Impact Socket Combo Set will have your wheel torque needs covered. It includes the most common wheel mounting socket and torque limits in one great tool kit. The lug nut sockets include protective sleeves and inserts to prevent wheel damage, and are color coded for quick reference. The 1/2" drive set consists of 4 Torque Limiting Extensions: 90, 100, 110 and 120ft/lbs AND 4 Protective Lug Nut Impact Sockets: 17mm, 19mm (3/4"), 21mm (13/16"), and 7/8". Packaged in a blow-molded plastic case.



76750

See page 184 for our Wheel Torque Chart part no. 70050

FORD SUPER DUTY TIE ROD SLEEVE ADJUSTER

This tool is specifically designed for use on the Ford Super Duty trucks as well as most other light trucks and vans. The extra long bar gives you maximum leverage to loosen rusted sleeves without injuring your knuckles. This 8 position tool allows 360° rotation without removing the adjuster block from the sleeve.



77350

APPLICATIONS

Dodge: 2500 & 3500

Ford: Twin I-Beam w/upper and lower ball joints

CAUTION: Not for use with impact wrenches (air tools).

FORD/DODGE/RAM COMBO SLEEVE PULLER

This sleeve puller will pull both OE and most aftermarket camber/caster sleeves quickly and efficiently, usually without damaging the ears of the sleeve. Heat treated high strength steel. Single-unit design with no loose parts.



77880



77928 BRAKE PEDAL DEPRESSOR

An adjustable steel plate extends the length of the bar to put constant pressure on the brake pedal.



77938

This product is not a locking device. Use with caution.

77938 STEERING WHEEL HOLDER

A must for proper alignments. This tool securely holds the steering wheel and covered hooks and base prevent damage to the steering wheel or seat.

77928

This product is not a locking device. Use with caution.

DEEP, THIN WALL FLIP SOCKETS

These 1/2" square drive impact sockets are deep and thin walled to reach areas conventional sockets can't. Each part number provides two sizes.

79230 - 3/4" and 13/16"

79240 - 19mm and 21mm



79230
79240

81139

MAGNETIC ADJUSTABLE CAMBER GAUGE

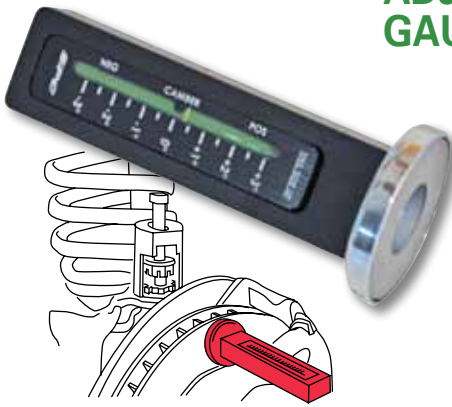

The 81139 is inexpensive, portable, and very accurate. It has a simple leveling adjustment of $\pm 3^\circ$. Housed in a durable, non-magnetic casing with a magnetic head that attaches firmly to rotors or spindles.

- 81134**
Replacement Bubble Vial
- 81133**
Replacement Magnet

- Time/money saving device.
- Return a strut to its original camber after repair or replacement.
- Measure amount of camber change movement before reinstalling alignment heads during camber kit installation.
- Check the amount of camber change before reinstalling tire and wheel assemblies on trucks receiving offset alignment bushings.
- Check camber change before, during and after EZ Cam™ (page 117) installation, saving time and money!

81309

STEEL WHEEL RIM STRAIGHTENING TOOL



For quick and easy removal of indentations on wheel flanges and rims of most vehicles. Allows proper tire seating, giving greater tire protection and durability. This tool is powder coated for added durability.

83125

HEAVY DUTY WHEEL WEIGHT TOOL



This heavy duty wheel weight tool has a special grip hammer and pliers for removal and installation of truck wheel weights. If you are using steel wheel weights, instead of lead wheel weights, this is the tool for you!

83775

GM ALIGNMENT TOOL

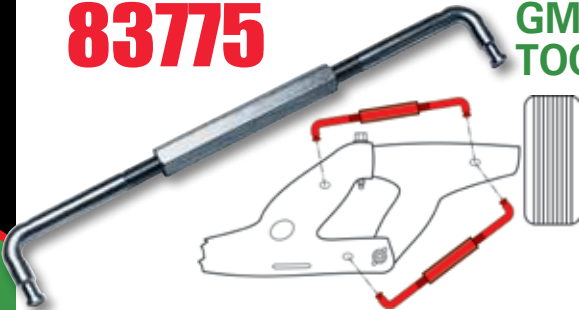

This tool allows for fine, accurate, easy adjustments of camber or caster on GM vehicles. No extra parts or cutting/grinding needed.

APPLICATIONS

Adjust front camber/caster

- Cadillac:** 2003-08 CTS, CTS-V
2004-09 SRX
- Chevrolet:** 1993-02 Camaro
- Pontiac:** 1993-02 Firebird, Trans Am

Adjust rear toe

- Buick:** 1979-93 Riviera
- Cadillac:** 1980-92 Eldorado, Seville
- Oldsmobile:** 1978-92 Toronado

83785

GM CAMBER/CASTER TOOL

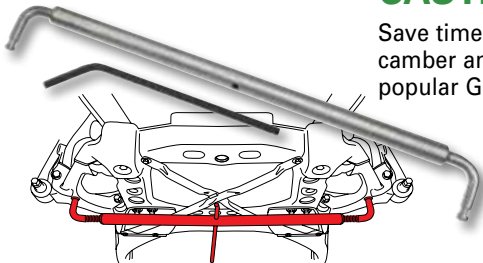

Save time and make adjusting front camber and caster a one-person job on popular GM platforms with this turn-buckle design tool. Simply attach the tool to the front lower control arms and dial in finite changes on GM mid-size SUV's, the Chevy SSR and the Cadillac CTS/CTS-V.

APPLICATIONS

- Buick:** 2004-07 Rainer
- Cadillac:** 2003-13 CTS, CTS-V
2005-11 STS
2004-09 SRX
- Chevrolet:** 2004-06 SSR
2002-09 Trailblazer
- GMC:** 2002-09 Envoy
- Isuzu:** 2003-07 Ascender
- Oldsmobile:** 2002-04 Bravada
- Saab:** 2005-09 9-7X



83820

FORD SUV CAM ADJUSTING WRENCH



This steel wrench is specifically designed to adjust the 86640 Camber/Caster Kit (page 131). Plated for durability.

APPLICATIONS

- Ford RWD/4WD:** 2003-06 Expedition
- Lincoln RWD/4WD:** 2003-06 Navigator

Applications

Alignment Parts

Heavy Duty

OE Replacement

Racing/Builders

Tools

Brake and CV

Gear/Index

APPLICATIONS

Buick: 1988 - 04 Regal
Cadillac: 2004 - 09 SRX
Chevrolet: 1990 - 01 Lumina Sedan
 1995 - 99 Monte Carlo
Oldsmobile: 1988 - 97 Cutlass/Supreme
Pontiac: 1995 - 96 Grand Prix

GM REAR TOE TOOL

83850

Tool allows quick, precise, and profitable adjustments of rear toe on both left and right sides of GM vehicles.



STEEL FILE SET 85125

Rotary Files

High quality carbide rotary files, ideal for elongating strut holes on many vehicles. Use when installing **82110**, **82120**, and **87350** adjusters. May be used with 1/4" or 3/8" drills at high speeds. Available individually. Use with **85774** Cool Tool cutting fluid (below).

INCLUDES: **85126** - 1/4" Rotary File (Max. Operating Speed 9,000 RPM)
85127 - 3/8" Rotary File (Max. Operating Speed 9,000 RPM)
85128 - 5/8" Rotary File (Max. Operating Speed 7,000 RPM)

3/8" ROTARY FILE SET 85130

This rotary file set is ideal for every technician. Be ready to elongate slots in aluminum and steel frames and brackets to accept larger offset cams. Includes one 85127 rotary file for steel, one 85137 rotary file for aluminum, and cutting fluid (85774) to extend your rotary file's life.

ALUMINUM FILE 85137

This 3/8" rotary file is specifically designed for Aluminum. Use it to quickly and cleanly expand cam slots in aluminum brackets and frames. It is an ideal tool to use when installing SPC Nissan and Infiniti Cams (pages 106, 110 and 111). Also is perfect when installing our Mustang Caster Bolts (page 111) and our Ford Crown Vic Front Cam Kit (page 132). Use with **85774** Cool Tool cutting fluid (below).



CAUTION: Always wear safety glasses when using cutting or grinding tools and equipment.

COOL TOOL FLUID 85774

This fluid lubricates the single rotary files and **85125** and **85130** rotary file sets (above), and the **68670** Rotor-Bor (page 168) to reduce stress on the cutting teeth. This product is highly recommended to prolong the life of all cutting bits used on steel.

Check out SPC's new Punch Tools to quickly elongate holes, page 170.

CAUTION: Not for use with impact wrenches (air tools).

3 IN-1 SPINDLE PULLER

85796 is a 3-in-1 puller that makes removing the spindle from four wheel drive vehicles much easier. This puller fits spindle sizes 1-1/2", 1-5/8" and 2" spindles that are OE on 4x4 trucks.



85796

APPLICATIONS

Dodge RWD: 1994 - 99 3500 Ram w/Mono
Dodge 4WD: 1994 - 99 2500HD, 3500 Ram
Ford RWD: 1990 - 90 Bronco II (Late 90)
 1992 & Up E150, E250, E350, E450
 2000 - 05 Excursion; 1987 - 96 F150
 1998 - 13 F250, F350 Twin I-Beam
 1987 - 98 F250, F350
Ford 4WD: 2000 - 05 Excursion
 1999 - 04 F250, F350 Solid Axles/Leaf Springs
 1992 - 98 F350 Crew Cab
Ford RWD/4WD: 1999 - 04 F450, F550
 1991 - 94 Explorer

TRUCK SLEEVE SOCKET

87175

This 1-1/2" socket is useful for adjusting both the OE and our popular **23130** and **23180** sleeve series (see page 75) for Ford and Mazda RWD and 4WD trucks with pinch bolt style suspension. For 1/2" drives.



APPLICATIONS

Ford: 1986 - 07 Taurus Sedans
Mercury: 1986 - 07 Sable Sedans

FORD/MERCURY REAR BUSHING ADJUSTING TOOL

87320

Many popular Taurus/Sable sedans utilize our **87330** Rear Camber/Toe Kit (page 132). The **87320** Bushing Adjustment Tool allows easy access to the head of the eccentric bushing to ease adjustment.



87325

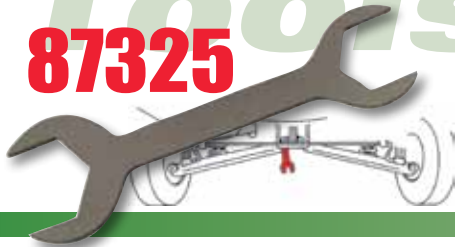

TAURUS & TEMPO REAR TOE WRENCH

This tool allows quick, precise, and profitable adjustments of OE rear toe on both sides of Ford and Mercury Sedans.

APPLICATIONS

- Ford:** 1986 - 07 Taurus Sedan
1986 - 94 Tempo Sedan
- Mercury:** 1986 - 07 Sable Sedan
1986 - 94 Topaz Sedan

87530



VW SHIM WRENCH

Designed to remove the rear hub when installing our **71520** and **71530** Series Volkswagen shims (page 103). This wrench is a must in assisting the installer when using these camber and toe shims.

87560

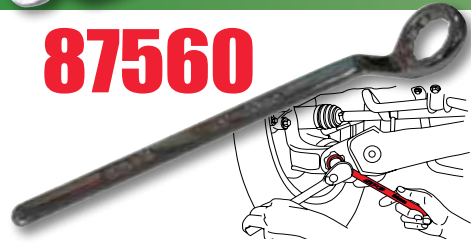

HONDA 24MM TOE ADJUSTING TOOL

This tool makes rear toe adjustment easy on many late model Hondas. The 24mm wrench can also be used on the new Acura ILX and Mini Coopers.

APPLICATIONS

- Acura:** 2013 & Up ILX
- Honda:** 2006 - 15 Civic
2007 - 16 CR-V
2003 - 11 Element
- Mini Cooper:** 2002 - 13 Cooper/
Cooper S, Conv., Clubman

87565 87566 87567

REAR TOE ADJUSTING TOOLS

Quickly and easily adjust rear toe with this tool from SPC. Simply use your 1/2" drive socket wrench to drive change on the rear toe adjustment brackets and save time on every alignment.

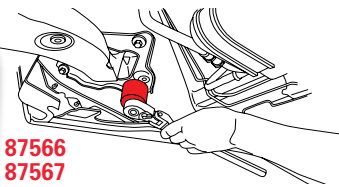
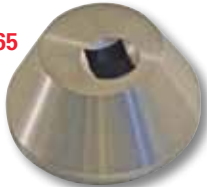

87565

87566
87567

APPLICATIONS

- 87565**
BMW: 3-Series (E46) and Z4 models
Equivalent to BMW tool #83300493306 and Bosch tool #323030.
- 87566**
MINI: All Mini Series
Equivalent to BMW tool #83300494002 and Bosch tool #324200.
- 87567**
BMW: 3-Series (E36)
Equivalent to BMW tool #88-9180.

87570



AUDI REAR CAMBER ADJUSTING TOOL

This custom tool makes adjusting the OE camber cams on the rear of Audis a snap. Even with tires on and the suspension loaded you will be able to access and tighten the nut. Simply loosen the cam bolt, adjust the camber bolt with the bolt's hex pilot, then hold it in place with the hex while you tighten the nut with SPC's custom 12-point box end wrench. The 87570 tool is angled to allow maximum access and clearance for rear camber adjustment.

APPLICATIONS

- Audi:** 2009 - 16 A4/S4,
A5/S5
2012 & Up A6
2012 & Up A7
2011 & Up A8

88325

CAMBER/CASTER WRENCH

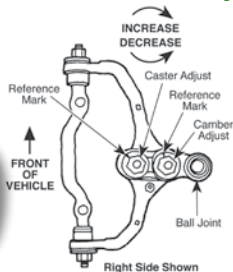

This unique camber and caster adjustment tool fits full size RWD Ford vehicles. Starting in the early 90s Ford RWD vehicles required rotating a separate cam for each angle adjustment. To adjust caster/camber use the **88325** wrench to rotate the cam. This wrench also holds the cam to prevent slipping when tightening the lock nut.

1/2" Drive

APPLICATIONS

- Ford:** 1992 - 02
Crown Victoria
- Lincoln:** 1991 - 02 Town Car
- Mercury:** 1992 - 02
Grand Marquis

Applications

Alignment Parts

Heavy Duty

OE Replacement

Racing/Builders

Tools

Brake and CV

Gear/Index

APPLICATIONS

Dodge/Ram RWD/4WD:
2008 & Up 4500, 5500

Sterling Bullet RWD/4WD:
2008 - 11 4500, 5500

DODGE/RAM PIN JOINT ADJUSTING WRENCH

88360

The 2-3/8" flat hex wrench is designed to make the installation of the **23850**, **23852** and **23854** (page 78) Dodge/Ram pin joints quicker and easier. Use a 1-1/2" socket to hold your adjustment and then tighten the jam nut with this tool.



CAUTION: Not for use with impact wrenches (air tools).

88830 is not recommended for use on Ford Motor Co. original equipment sleeves. Use 77880 (page 168 for OE Sleeves).

FORD/DODGE SLEEVE PULLER (AFTERMARKET)

88830

This puller is designed to work specifically with the **23100** (page 74) sleeves. It will allow the technician to pull the sleeves without normally breaking the ears off the sleeve.



Dual socket inner tie rod removal tool

Fits 1-3/16" or 1-5/16" hex. inner tie rod ends on Fords and Chryslers with TRW racks.

1-3/16" hex tool - for inner tie rod ends on Ford Escort, Tempo, Topaz, Lynx.

1-5/16" hex tool - designed for inner tie rod ends on 1986 - 07 Taurus/Sable.

1-7/16" hex tool - designed for GM Saginaw rack and pinions.

CAUTION: Not for use with impact wrenches (air tools).

INNER TIE ROD END WRENCH SET

89000

Set includes a Dual Socket Inner Tie Rod Removal Tool along with 1-3/16", 1-5/16" and 1-7/16" hex tools.

1-3/16" Hex **1-5/16" Hex** **1-7/16" Hex**



Dual Inner Tie Rod Removal Tool

SPC TAPE MEASURE

91045

High quality 16' tape measure with SPC logo. Included in our Off-Road (91025) and Heavy Duty (91040) FasTrax™, this tape measure also works great for measuring toe with our standard (91000) and our Performance (91010) FasTrax™.



APPLICATIONS

Ford: 1986 - 05 Taurus Station Wagon

Mercury: 1986 - 05 Sable Station Wagon

FORD STATION WAGON REAR TOE TOOL

97650

Taurus and Sable Station wagons have a sprocket type cam to adjust rear toe. This tool engages the sprockets and allows the technician to turn the cam.



APPLICATIONS

99361 extends 46-74 in. for light trucks & cars.

99374 extends 39-60 in. for standard and compact cars.

TOE MEASURING GAUGES

99361 99374

Spring-loaded gauges easily adapt to a variety of tread widths in order to give fast, accurate toe readings.



WHEEL SPREADER

Take the play out of front wheels during alignment! Place this spring-loaded pressure bar between the tires to assure a more accurate alignment. **A must for Mercedes vehicles.**



99918



Applications
Alignment Parts
Heavy Duty
OE Replacement
Tools
Brake and CV
Gear/Index

91000
91010
91025

FASTRAX™ CAMBER / CASTER GAUGE

This great tool is a must for all garages and shops -plus, it can't be beat at the track.

Portable, hands-free alignment can be done quickly and easily with the **FasTrax™ Adjustable Camber/Caster Gauge**. This tool will help you fine tune your alignment for optimal tracking and handling while minimizing alignment headaches.

- Includes gauge and wheel mount.
- Displays Camber $\pm 4^\circ$ / Caster -4° to $+12^\circ$.
- Saves time and tires.
- Accurate, rugged and easy-to-use

91000 Standard - Fits wheels 13" to 17"
Optional Toe Adapter Kit (91100) sold below.

91010 Performance - Fits wheels 17" - 22"
Optional Toe Adapter Kit (91100) sold below.

91025 Off-Road - Fits Wheels 13" to 17"
Align off-road wheels - tire sizes up to 44".
Includes longer toe arms, bungee cord & tape measure.

91030 No lip adapter
A quick adapter to attach the FasTrax to wheels without an outer "lip". Fits on the 91000, 91010 and 91025.

91040 Heavy Duty - Fits Wheels 21" to 26"
Perfect to add to your PMs - Check your alignment in just 5 minutes. Includes extra length toe arms, heavy duty tape measure and no lip adapters.

91040 - See Page 149 for more

If you do these jobs at your garage - you need the FasTrax Camber/Caster Gauge!

- Install adjustable control arms
- Replace idler arms and tie rod ends
- Replacing struts
- Install adjustable bushings
- Collision repair estimates
- Frame straightening

SPC'S Alignguide™ is the perfect companion for our FasTrax. For more on this alignment specification app see page 179.



91025

91030



We have a FasTrax for your use:

- Garage
- Racing
- Performance
- Off-Road
- Muscle
- Semi's



91010



91000
w/91100



91025



91100

FASTRAX™ TOE ADAPTER SET

Simply lower the toe arms and insert tape measure into slot. Then measure to opposite tire reference point for accurate and fast toe readings. Includes 2 arms and reinforcement blocks that install easily onto either the **91000** or the **91010**.

For more convenience we recommend using two FasTrax with Toe Adapters (use one on each side of the vehicle).



Applications

Alignment Parts

Heavy Duty

OE Replacement





Racing/Builders

Tools

Brake and CV

Gear/Index

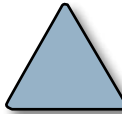
Carbide Brake Lathe Inserts

Brake Lathe	Models	SPC Part #	Per Pack	OEM Part #	Cutting Edges	Description	Bits - Actual Size	
Accu-Turn	8911, 8922, 8944, 8989, 8991, 8993	06005	5	433795	3	Positive rake carbide bit.	 <p>SPC Part # 06005 06010 40702 40706 40710</p>	
		06010	10	433796	3			
All Tool	747	06506	6		3	Positive rake carbide bit.		
Ammco	1000, 1001, 3000, 4000, 4100, 7000, 7700 On-vehicle lathe 700, 705, 710 Drum side on 3850	06202	2	6914-2	12	Negative rake carbide bit.		
		06206	6	6914-6	12			
		06210	10	6914-10	12			
	1000, 1001, 3000, 4000, 4100, 7000, 7700 On-vehicle lathe 700, 705, 710 Drum side on 3850	06610	10		12-18	Round bits for round tool holders.		
		10306	6	7681-6	3	Positive rake carbide bit.		
FMC-John Bean/Barrett	67BSD, 67DLX, 67GSA, 69DLX, 701ECF, 601PF FMC or Barrett 400, 500, 600, 700	40702	2	90487	3	Positive rake carbide bit with .020 radius. Left and right hand tool holders.		 <p>SPC Part # 06506 06510 06202 06206 06210 10306</p>
		40706	6	90488	3			
		40710	10	90488	3			
		10306	6	91212	3		Positive rake carbide bit.	
	500 Series On-The-Car Lathe	06202	2	90817	3	Negative rake carbide bit.		
		06206	6		3			
		06210	10		3			
Hofmann/RJ West	True-Cut 400/401	40702	2	722-83-4	3	Positive rake carbide bit.		
		40706	6		3			
		40710	10		3			
	660	06202	2	6914-2	12	Negative rake carbide bit.		
		06206	6	6914-6	12			
		06210	10	6914-10	12			
Hunter	BL500, BL501, BL505	06506	6	221-583-3	3	Positive rake carbide bit. For Rotors.	 <p>SPC Part # 70210 90310</p>	
		06510	10					
	201,205	70210	10	V302-07-167	12	Negative rake carbide bit.		
		80206	6	109-1092-23	3	Positive rake carbide bits for rotor and drum.		
Kwik-Way	SDL, DL, 850 Disc Lathe, NDL, BDL, CBL Kwi-Lathe On-The-Car #108-0005-04 ROTUNDA, LINE-O-TRONICS	80210	10		3			
		06506	6	8711	3	Positive rake carbide bits for rotor and drum.		
Performance	66, 6600, 7100, 7200, 7600	06510	10	8711	3			
		40702	2	W139	3	Positive rake carbide bit.		
Perfect Equipment	400 & 450 Twin Turn	40706	6		3			
		40710	10		3			
		06906	6		3	Positive rake carbide bit for Ford.		
Pro-Cut	Warthog, PFM 9.2 DRO, PFM 9.1 DRO 610 On-The-Car Lathe	06910	10	50-742	3			
		70606	6	50-701	3		Positive rake carbide bit.	
Rels	SW504 Swing Arm	80206	6	SW4236-15	3	Positive rake 15 degree carbide bit.		
		80210	10		3			
	204C, 204D, 204S, 205DC, 415	90310	10	29687V	3	Positive rake carbide bit.		
		06202	2		12			
	2000	06206	6	45001	12	Negative rake carbide bit.		
		06210	10		12			
		10306	6		3		Positive rake carbide bit.	
RTI	BRC500, BRC550 BRC35 On-The-Car Lathe	10306	6		3	Positive rake carbide bit.		
Snap-On	YA180,YA281	80206	6	BTK10A	3	Positive rake carbide bit.	 <p>SPC Part # 06610</p>	
Van Norman	204S Old Style, 205DR, 301, 303, 304, 305, 310, 404, 404,4 05	90203	3	302167	2	Positive rake parallelogram drum bit.		
		90310	10	129687 866561	3	Positive rake bit.		
VGB	610 On-The-Car Lathe	70606	6		3	Positive rake carbide bit.	 <p>SPC Part # 90203</p>	



Tech Tip: Positive rake bits usually have 3 cutting edges, have a tapered shape to them, and are installed on a flat tool holder. Negative rake bits can have 12 cutting edges, are square with the edges, and are used with an angled tool holder.

Applications
Alignment Parts
Heavy Duty
OE Replacement
Racing/Builders
Tools
Brake and CV
Gear/Index

00191

RIGHT HAND TOOL HOLDER

Fits **AMMCO** Model 7000 Disc Rotor Lathe; 3000, 4000, 4100 Drum Lathes and **HOFFMAN** Model 660. Complete with one Carbide Insert No. 062.



3/8" Square Shank

00404

RIGHT HAND TOOL HOLDER

Fits all **FMC/JOHN BEAN** Brake Lathes and **ACCU-TURN**. Complete with 1 Carbide Insert No. 407. **FMC/JOHN BEAN, ACCU-TURN**



3/8" Square Shank

00192

LEFT HAND TOOL HOLDER

Fits **AMMCO** Model 7000 Disc Rotor Lathe; 3000, 4000, 4100 Drum Lathes and **HOFFMAN** Model 660. Complete with one Carbide Insert No. 062.



3/8" Square Shank

00405

LEFT HAND TOOL HOLDER

Fits all **FMC/JOHN BEAN** Brake Lathes and **ACCU-TURN**. Complete with 1 Carbide Insert No. 407. **FMC/JOHN BEAN, ACCU-TURN**



3/8" Square Shank

06700

RIGHT HAND AND LEFT HAND TOOL HOLDERS

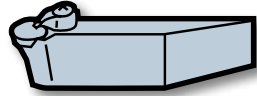

3/8" Square Shank

Fits **ALL TOOL, AMMCO, HUNTER, PERFORMANCE,** and **RELS.** Complete with Carbide Insert No. 06610. Number 06700 includes 2 holders, one right hand and one left hand, with one left and one right bit.

Rotor Silencers



00050

00050 ON CAR BRAKE LATHE SILENCER

Designed for **Pro Cut** on car lathes, this silencer fits on top of the cutting tools, deflecting chips and damping chatter.



00069

00069 VENTILATED DISC SILENCER

Fits any ventilated rotor and is made of natural rubber with metal weight inserts. It easily wraps around rotor to deaden vibration and chatter.

DIMENSIONS: 32" long.



00070

00070 BENCH BRAKE LATHE SILENCER

This standard style silencer fits on top of the cutting tools, deflecting chips and damping chatter.



00080

00080 DRUM SILENCER

00080 drum silencer fits any passenger car drums. Made of natural rubber. It wraps around the drum and is secured with a buckle.

DIMENSIONS: 1-3/4" wide, 72" long



00085

00085 DRUM SILENCER

00085 is a heavy duty brake lathe silencer for use on truck drums.

DIMENSIONS: 2-3/4" wide, 72" long

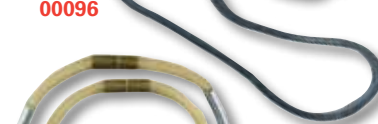

00094,
00096

00094, 00096 SILENCER BANDS

Large and small black rubber gasket-type silencer bands for solid rotors.

DIMENSIONS: **00094:** - 1/4" x 3/8" x 9" diameter **00096:** - 1/4" x 3/8" x 6-1/2" diameter



00095,
00195

00095, 00195 VENTILATED ROTOR DISC SILENCERS

Used on any brake lathe and with any ventilated rotor, they suppress vibration and noise. Segmented silencer is made of the finest latex rubber tubing with four (4) steel tubes to quiet chatter. Recommended for all disc resurfacing machines.

DIMENSIONS: **00095:** - 9" diameter **00195:** - 7" diameter



00098

00098 ADJUSTABLE VENTILATED ROTOR SILENCER

This adjustable silencer is made of latex tubing with lead weight implants.

DIMENSIONS: 32" long



00099

00099 ELASTIC ADJUSTABLE SILENCER

Dampen chatter, noise and vibration on solid and vented rotors.

DIMENSIONS: 3/16" x 3/8" x 6-3/4" diameter. Stretches to 19" diameter



09800

09800 SPRING LOADED SILENCER

Replacement for **Ammco 9800** Spring Loaded Silencer



Replacement knob for AMMCO Lathes (1 each).

GAUGE FOR RUN-OUT SETS



This replacement gauge fits our stand-alone run out gauge (#64250 - below).

UNIVERSAL RADIAL RUN-OUT GAUGE

The Universal Radial Run-Out Gauge displays exact measurements for tire, wheel, and disc brake run-out. This gauge also measures ball joint and tie rod play and adjusts height to adapt to both automotive and heavy truck applications. This is a great tool when measuring those hard to reach areas.



Tire Radial Run-Out

- Measures out of round condition which can cause front end vibration
- Pinpoints high and low spots in the tire

Brake Rotor and Hub Run-Out

- Measure brake rotor high spots and out of round
- Measure hub radial play

Suspension/Ball Joint Play

- Measure kingpins, ball joints and tie rod end axial and radial play
- Use extender rods for hard to reach areas

Wheel Lateral Run-Out

- Check for bent or out of round wheels
- Out of round wheels may cause a shimmy condition

Also measures ball joint play (set-up pictured) and tie rod play Please refer to Specialty Products Wheel Alignment Specifications Book (part #82020 psg 184) for ball joint specifications.

Machined roller & heavy duty tripod for smooth, accurate readings

Includes ball joint/tie rod extenders



Specialty Products carries a complete line of alignment parts, tools and accessories for OTR Vehicles

From Tandem and Axle Shims to Wheel Centering Products SPC is your Heavy Duty Alignment Headquarters. See pages 141-149.



Applications
Alignment Parts
Heavy Duty
OE Replacement
Racing/Builders
Tools
Brake and CV

02099



CV BOOT CLAMP INSTALLATION TOOL

Designed for the low-profile clamps used to hold C.V. Boots on FWD vehicles. The **02099** comes complete with a ratchet. We recommend using this tool when installing our **87365** Crown Victoria Camber Kit (page 132).

33001



UNI-FIT CV SOLID REPLACEMENT BOOT

Manufactured of Neoprene, the boots are resistant to oil, grease, water, drying, abrasion, and tearing. They are easy to install and fit most front wheel drive passenger cars and light trucks. Each kit includes boot, OE type grease, universal clamps, and easy installation instructions. One size fits most cars.

This Conicalution™ design features continuously rounded fluting that evenly distributes stress and reduces boot wear.

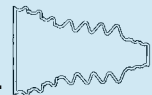

- Rapid Turnover
- Reduces Inventory
- Simple to Catalog
- Easy Ordering
- No Mix-ups
- Never Obsolete
- Saves Space
- Durable

33053 BOOT CLAMPS

Stainless steel replacement 19 inch bands in for securing the 33001 Uni-Fit boot.

33053 – (Set of 10) - 19 in.

Use our #02099 Boot Clamp (above) Installation Tool to make tightening these clamps easy!

32012



UNI-FIT REPLACEMENT BOOT ECONOMY PACK (SET OF 12)

The Economy Pack is ideal for the shop that wants to save inventory dollars. Bulk buying saves you time and money by having the lowest possible price boots waiting on your shelf. No more waiting for delivery service, no missed sales.

PACKAGE INCLUDES EVERYTHING NEEDED FOR CONTINUOUS SERVICE:

Use our #02099 Boot Clamp (above) Installation Tool to make tightening these clamps easy!

32012 - Uni-Fit CV Boots (12), Grease tubes (12), 18-1/2 in. Stainless steel bands (12), 7-1/2 in. Stainless steel bands (12), Instruction sheets.

33020



UNI-FIT STEERING BOOT (PAIR)

This one-size fits-all Uni-Fit rack & pinion boot has been supplied throughout the world since 1981. It is made of durable, neoprene material that is oil, grease and water resistant. The kit includes two boots and four cable ties along with an installation cone to service both sides of the rack.

Specialty Products' parts, tools and accessories are available world wide!

Applications for many European, Asian and Latin American specific vehicles are available on our website. We also sell specific parts into these markets, such as our front upper adjustable control arms for the Isuzu D-Max (a popular SUV in Australia) and vehicle specific shims for the tuner/ modifier favorite, Renault Cleo, in Europe.



D-Max Front UCAs



Cleo Shims