



SUNCOAST
DIESEL TRANSMISSIONS



SunCoast Converter's Inc. was established in 1989 as a two-man operation in the back of a transmission shop. Today, SunCoast has grown to over thirty employees and over 68 thousand sq. ft. of room to conduct operations. SunCoast started with a quest to answer the demand for quality after-market torque converters, transmissions, and parts. Since then, SunCoast has identified and corrected failure points within numerous OEM transmissions and torque converters. SunCoast formulates test data using real world scenarios, along with the latest technology and design methods, to manufacture parts that correct the cause of these failures. This practice has helped SunCoast stay ahead of its competitors in not only quality, but also extending past that to the winners podium for its customers and sponsored vehicles. The company's research and development, combined with years of transmission and torque converter experience, is unparalleled. Pride in design, manufacturing, technical support, and customer satisfaction has been and always will be the primary goals of SunCoast. The company tries to educate the public on the differences in product from other manufacturers, mainly so its customers know when they are getting product of



GET. MORE.

substance versus a product that is simply relabeled. SunCoast will never sacrifice quality for price point. They have numerous CNC machines that run around the clock making parts for in-house use. They also have multiple CAD developers, as well as programmers on staff, making innovation in design second nature.

SunCoast is known throughout the transmission world for its top-of-the line torque converters, because the company has taken the time to listen, learn, research, and respond to its customers' suggestions, with outstanding results. The company will continue to make its converters and transmissions the best in the business, while continuously researching new technologies that shine new light on the industry. Design copying is easy. Innovations however, are more difficult.



6-8 DODGE TRANSMISSIONS



9-11 DODGE CONVERTERS



12-15 DODGE REBUILD KITS



16-21 DODGE ACCESSORIES



50-52 WARRANTIES

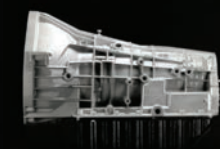

22-23 FORD TRANSMISSIONS



24 FORD CONVERTERS



25-28 FORD REBUILD KITS



29-32 FORD ACCESSORIES



53-54 SUNCOAST SWAG



34-35 GM TRANSMISSIONS



36-37 GM CONVERTERS

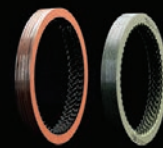

38-42 GM REBUILD KITS



43-49 GM ACCESSORIES



55-59 BRAND GUIDELINE

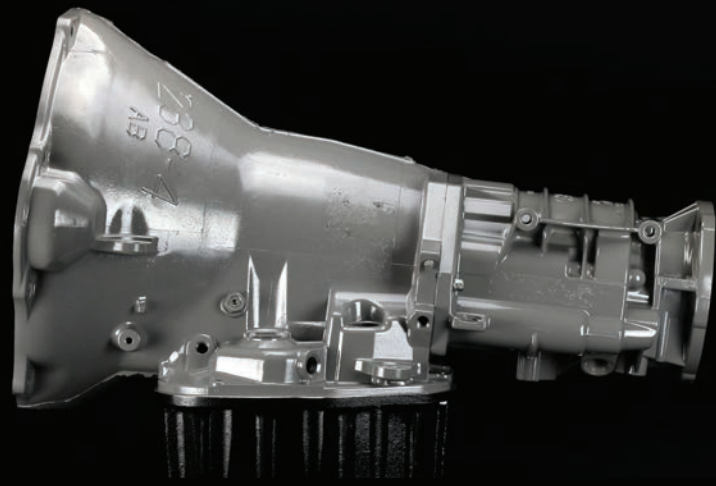

graded hard parts such as billet input, intermediate, output shafts, and drums vary depending on application (competition unit).

The SunCoast transmission includes increased clutch count with high-energy friction materials of choice (Alto® or Raybestos®), treated steels, and can also feature upgraded parts.

- **Billet billet band**
- **Billet strut & anchor**
- **Billet forward & direct piston**
- **Billet 4 ring accumulator piston**
- **Billet upgraded governor solenoid**
- **Billet 1-2 servo**
- **Multiple input shaft options (some require custom torque converter)**

DODGE TRANSMISSIONS 46RH | 47RH | 47RE | 48RE

The SunCoast Dodge series transmission assemblies offer consumers the ultimate in performance and durability, which are needed to deliver Cummins' power to the ground. All transmissions are rebuilt to exact specifications with new bushings, seals, rings, frictions, and steels. All hard parts are inspected, machined, and/or replaced to meet specifications. These blueprinted assemblies include the SunCoast valve body and are available with the Mag-Hytec double deep pan option. All transmissions are dyno tested to insure pressure and flow calibrations. Up-

The SunCoast transmission includes increased clutch count with high-energy friction materials of choice (Alto® or Raybestos®), treated steels, and also features:

Part Numbers:



1989-1993
 PLSD-46RH-2X
 PLSD-46RH-4X

46RH 2X TRANS ASSEMBLY
 46RH 4X TRANS ASSEMBLY



1994-1995
 PLSD-47RH-2X
 PLSD-47RH-4X
 PLSD-47RH-COMP

47RH 2X TRANS ASSEMBLY
 47RH 4X TRANS ASSEMBLY
 47RH COMP TRANS ASSEMBLY



1996-2003
 PLSD-47RE-2X
 PLSD-47RE-4X
 PLSD-47RE-M-COMP-2X
 PLSD-47RE-M-COMP-4X

47RE 2X TRANS ASSEMBLY
 47RE 4X TRANS ASSEMBLY
 47RE 2X OM3GA COMP TRANS ASSEMBLY
 47RE 4X OM3GA COMP TRANS ASSEMBLY

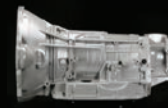

2003.5-2007
 PLSD-48RE-2X
 PLSD-48RE-4X
 PLSD-48RE-COMP-2X
 PLSD-48RE-COMP-4X
 PLSD-48RE-M-COMP-4X

48RE 2X TRANS ASSEMBLY
 48RE 4X TRANS ASSEMBLY
 48RE 2X COMP TRANS ASSEMBLY
 48RE 4X COMP TRANS ASSEMBLY
 48RE 4X OMEGA COMP TRANS ASSEMBLY

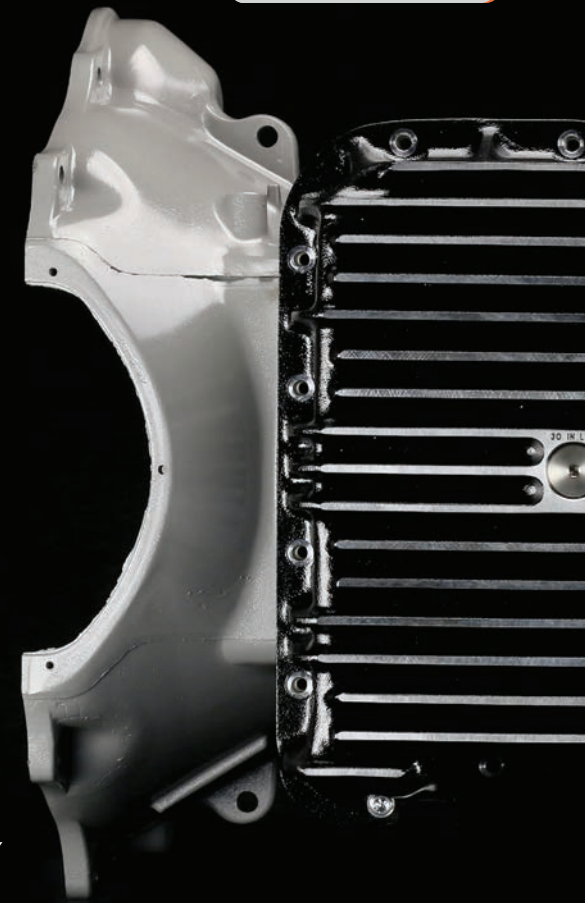

DODGE TRANSMISSION 68RFE

The SunCoast Dodge 68RFE competition transmission assembly offers the ultimate in performance and durability for the 6.7L Cummins.

Boasting 40% more surface area than a stock 68RFE, the over-sized, double-sided, SunCoast-designed clutches are the key to getting the 68RFE to hold anything thrown at it. The oversized clutches are housed in patented billet inner and outer "M3GA" drum setup.

The "low and reverse sprag" has been upgraded to SunCoast's spring and roller sprag setup. The 4C snapping retainer has been upgraded with SunCoast's billet snapping retainer. In addition, the 2C and 4C valve body seals have been replaced with billet units to prevent factory seal blowouts. Every M3GA68 pump is machined to replace worn TC limit valves and line pressure modifications to allow for more pressure. All hard parts are inspected, machined, modified, and/or replaced to meet SunCoast's specification, and all units are street tested prior to shipment to ensure the ultimate in performance and reliability for consumers. Included with the purchase of a M3GA68 is a billet input shaft, custom valve body modifications, as well as new bushings, seals, rings, frictions, and steels.

- SunCoast signature M3GA drum-class 3 hard anodized
- Custom SunCoast sprag

Part Numbers:



2007.5-2014
PLSD-68RFE-M3GA

- **Not included, but highly recommended with the purchase of a complete transmission, is a Mag-Hytec deep pan, triple disc torque converter and an SFI approved billet flex plate/flywheel.**

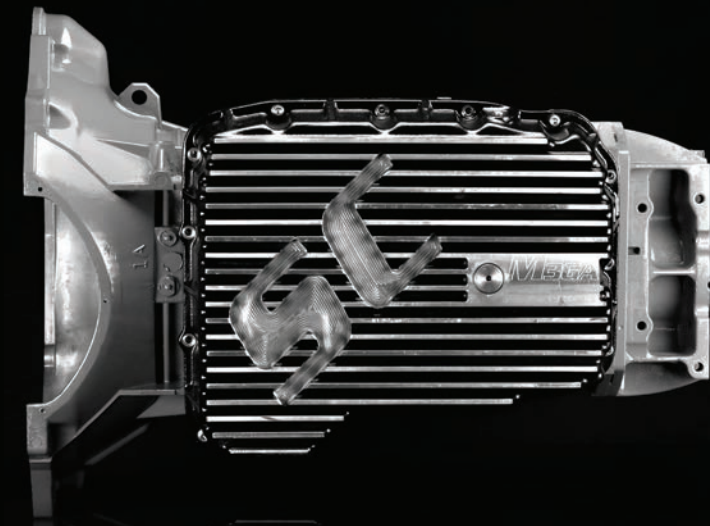

DODGE 4748RE TRIPLE CLUTCH CONVERTERS

SunCoast Dodge series torque converters are designed and manufactured in-house. Because of this, the company is able to supply almost any request in regard to stall, torque multiplication, efficiency to custom applications.

Custom-designed billet stator provide better torque and efficiency prior to lockup. SunCoast's custom designed CNC machined billet piston houses its 3 disk converter lock up clutches and will not flex like other billet converters on the market. This clutch then applies to the custom CNC machined forged billet cover.

**Core deposit required.*

Multiple billet stators for various stalls (1800-3000 stocked)

- Custom pump and turbine modifications (in-house)
- Tig welding to reinforce furnace brazed fins
- Proprietary converter clutches with trapezoid clutch teeth (no round tabs)
- CNC machine billet stators (1800-3000 RPM stall)
- 4140 turbine splines (heat treated depending on application)
- Billet steel and aluminum pistons
- Forged billet cover strength (proprietary Raybestos converter clutch plates)
- Pressure tested welds/spun balanced to ensure highest quality



DODGE 68RFE TRIPLE CLUTCH CONVERTERS

This triple disc torque converter for the 2007-Current 68RFE equipped 6.7L Cummins is manufactured and assembled at SunCoast. Boasting more than 3.4x the lockup clutch surface apply area over stock (8.7" vs. 29.7") and distributing the load over three separate surface apply areas, SunCoast's triple disc converters are sure to put all of the power to the ground. Starting with a solid chunk of steel, the cover is machined to exact specifications. Utilizing SunCoast's exclusive trapezoidal teeth design, the lockup portion of the converter is seamlessly integrated into the cover, eliminating a weak point and common source of chatter. An upgraded billet lockup apply piston is able to transfer a much higher pressure to the lockup clutch without sacrificing durability. Instead of the factory-style plastic stator cap/thrust spacer, SunCoast utilizes a metal Torrington roller style bearing, which is better suited to take the heat, as well as wear and tear. The turbine assembly is TIG reinforced and heat-treated. This exponentially increases its lifespan under harsh conditions. Stall on this model is approximately 2000 RPM, and much more efficient at energy transfer than the factory offering.

- **Forged billet steel covers**
- **Billet aluminum stators**
- **Pressure tested welds**
- **Spun balanced on Stewart Warner pro-bal**
- **Furnace brazed & tig welded**
- **Signature trapezoid clutch teeth (no Rund tabs)**
- **3 year warranty**



PART NUMBERDESCRIPTION WEIGHT

2361819	2200 STALL 12V SINGLE DISK	72lbs
2361819-3D	2200 STALL 12V 3D CONVERTER	78lbs
2361819-3D-DF	2200 STALL DURAFLITE REG. SHAFT	80lbs
2361819-3D-PF	2200 STALL POWERFLITE REG. SHAFT	80lbs
2361822-3D	2200 STOCK STALL 3D CONVERTER	78lbs
2361825-3D	2500 STALL 3D RACE CONVERTER	78lbs
2361825-PF-3D	2500 STALL POWERFLITE CONVERSION	80lbs
2361826-1-3D	2600-2700 STALL RACE/SLED CONVERTER	78lbs
2361826-3D	2600 STALL RACE/SLED CONVERTER	78lbs
2361827-3D	2700-3000 STALL RACE/SLED CONVERTER ...	78lbs
2361827-PF-3D	2700-3000 STALL POWERFLITE CONVERTE ..	80lbs
2361838	1800 LOW STALL 24V SINGLE DISK	70lbs
2361838-3D	1800 LOW STALL 3D CONVERTER	78lbs
2361844	2000 STALL 24V SINGLE DISK	70lbs
2361844-3D	2000 STALL 24V 3D CONVERTER	78lbs
2361848	2000 STALL 24V SINGLE DISK	70lbs
2361848-3D	2000 STALL 24V 3D CONVERTER	78lbs
2361848-3D-250 ..	2000 STALL 48/68 3D CONVERSION	78lbs
2361848-9	2200 STALL SINGLE DISK CONVERTER	70lbs
2361848-9-3D	2200 STALL 3D CONVERTER	78lbs
23618-SRT-24-3D ..	2400 STALL V-10 3D CONVERTER	78lbs
23618-SRT-26-3D ..	2600 STALL V-10 3D CONVERTER	78lbs
2451816	518 NON LOCKUP CONVERTER	65lbs
2451844	518 NON LOCKUP LOW STALL CONVERTER	65lbs
2561819-3D	2200 STALL OMEGA 3D CONVERTER	78lbs

PART NUMBERDESCRIPTION WEIGHT

2561825-3D	2500 STALL OMEGA 3D CONVERTER	78lbs
2561827-3D	2700-3000 STALL OMEGA 3D CONVERTER	78lbs
2561844-2-3D	2100 STALL OMEGA 3D CONVERTER	78lbs
2561844-3D	2000 STALL OMEGA 3D CONVERTER	78lbs
2561844-3D-6.7	2000 STALL OMEGA 48/68 CONVERSION	78lbs
2561848-3D	2000 STALL OMEGA 3D CONVERTER	78lbs
2561848-3D-DF	2000 STALL DURAFLITE 3D CONVERTER	80lbs
2761825-3D	2500 STALL MEDIUM SHAFT 3D CONVERTER ...	78lbs
68RFE-46-3D	1900-2000 STALL 3D CONVERTER	78lbs
AS68-3D	AS68RC CONVERTER	80lbs





DODGE REBUILD KITS

SunCoast's Dodge series rebuild kits cover all years from 1989-2015 (kit part number dependent upon year). These kits utilize the latest proven friction materials and steel technology from industry leading companies such as Alto® and Raybestos®. SunCoast works directly with these companies to design and manufacture proprietary exclusive SunCoast product lines, giving the end user uncompromised quality throughout the entire transmission. SunCoast has designed these kits in-house to exact specifications for many intents, including but not limited to towing, sled pulling, racing or having a vehicle to get from point A to point B. Along with these kits, SunCoast

has a full line of billet single/triple disc torque converters ranging from 1800 stall to approximately 3000 RPM (manufactured in-house). In addition the company has multiple input/output shaft options, multiple custom valve body options ranging from forward manual, reverse manual, trans brake, and electronic valve bodies, and billet steel and aluminum drums (year dependent) SFI approved flex plates, SFI approved transmission jackets, and much more.

PRODUCT HIGHLIGHTS

- **Billet 2nd gear band**
- **Billet strut anchor**
- **Billet accumulator (to replace the OEM plastic one).**

• **Governor pressure sensor - this is an upgrade that can be included in the kit or purchased separately. It has proven itself to be the most reliable governor pressure solenoid on the market. This part consists of a 4L60E EPC solenoid which is made from aircraft grade T-56 Billet Aluminum - this means no warping, leaking, sweating, or cracking and means it provides far more consistent pressures.**

• **SunCoast's billet 1-2 servo has 16% more apply area and provides more band holding power in second gear. Its easy-to-install part improves 1-2 and 2-3 shifts and features improved seal design which conserves pump volume.**

MEGA-47 - 1

DIRECT

(5) Alto frictions and (6) steels

OR

(6) Raybestos frictions and (6) steels
(1) selective steel

3 selective snap rings included
Custom direct apply plate

FORWARDS

(4) Alto frictions, (3) Kolene steels

OR

(4) Raybestos frictions, (3) Kolene steels.

OVERDRIVE DIRECT

(10) Alto frictions, (9) Kolene steels

OR

(10) Raybestos frictions, (9) Kolene steels

OVERDRIVE BRAKE

(6) Raybestos frictions, 6 Kolene steels and a custom apply plate

MEGA - 47 - 2

INCLUDES MEGA-47-1 COMPONENTS

In addition to:

Billet 2nd gear band
Billet strut
Billet anchor
Billet accumulator piston (4) ring
Billet forward piston
Billet direct piston
Billet 1-2 servo
Direct springs (10)
SunCoast Gasket & Sealing Kit
Pump Bushing
Filter

MEGA - 47 - 3

INCLUDES MEGA-47-1 / MEGA-47-2 COMPONENTS

In addition to:

Upgraded governor pressure solenoid
Transco® shift kit
Upgraded valve body electronics

MEGA - 48 - 1

DIRECT

(6) Alto frictions and (6) steels

OR

(6) Raybestos frictions and (5) steels
(1) selective steel

3 selective snap rings included

FORWARDS

(4) Alto frictions, (3) Kolene steels

OR

(4) Raybestos frictions, (3) Kolene steels.

OVERDRIVE DIRECT

(10) Alto frictions, (9) Kolene steels

OR

(10) Raybestos frictions, (9) Kolene steels

OVERDRIVE BRAKE

(6) Raybestos frictions, 6 Kolene steels and a custom apply plate

MEGA - 48 - 2

INCLUDES MEGA-48-1 COMPONENTS

In addition to:

- Billet 2nd gear band
- Billet strut
- Billet anchor
- Billet accumulator piston (4) ring
- Billet forward piston
- Billet direct piston
- Billet 1-2 servo
- Direct springs (10)
- SunCoast Gasket & Sealing Kit
- Pump Bushing
- Filter



MEGA - 48 - 3

INCLUDES MEGA-48-1 / MEGA-48-2 COMPONENTS

In addition to:

- Upgraded governor pressure solenoid
- Transco® shift kit
- Upgraded valve body electronics



MEGA - 68 - 1

4C CLUTCH

- (4) Frictions and (4) steels
- (1) Pressure plate

2C CLUTCH

- (5) Frictions and (4) Thin steels
- (1) Thick steel
- (1) SunCoast Billet Aluminum Piston

OD / UD Clutch

- (10) External thin single sided frictions
- (1) Internal thin single sided frictions
- (5) Thick external single sided frictions
- (5) Thick internal single sided frictions
- (2) Custom cut SunCoast pressure plates

REVERSE CLUTCH

- (2) double sided frictions
- (1) Kolene® Steel

LOW & REVERSE CLUTCH

- (7) External single sided frictions
- (7) Internal single sided frictions
- (4) Sealing D-Rings

MEGA - 68 - 2

INCLUDES MEGA-68-1 COMPONENTS

In addition to:

- SunCoast gasket and sealing kit
- Spin on filter
- 68RFE pie plate
- Inner piston
- Outer piston
- TransGo® 68RFE shift kit

MEGA - 68 - 3

INCLUDES MEGA-68-1 COMPONENTS

In addition to:

- Valve body Separator plate (year dependent)
- 68RFE Billet Sprag
- Pressure Regulator valve

PART NUMBERDESCRIPTION WEIGHT

M3GA-47-0	M3GA 47-0 ALTO CLUTCH & STEELS	11lbs
M3GA-47-1	M3GA 47-1 ALTO CLUTCHES,STEELS,PP	13lbs
M3GA-47-2	M3GA 47-2 ALTO REBUILD KIT	18lbs
M3GA-47-2B	M3GA 47-2 ALTO REBUILD KIT	18lbs
M3GA-47-2BL	M3GA 47-2 ALTO 00-03 REBUILD KIT	18lbs
M3GA-47-3BE	M3GA 47-3 ALTO 96-99 REBUILD KIT	24lbs
M3GA-47-3BH	M3GA 47-3RH ALTO 94-95 REBUILD KIT	24lbs
M3GA-47-3E	M3GA 47-3RE ALTO 96-99 REBUILD KIT	24lbs
M3GA-47-3H	M3GA 47-3RH ALTO 94-95 REBUILD KIT	24lbs
M3GA-47-3L	M3GA 47-3RE ALTO 00-03 REBUILD KIT	24lbs
M3GA-47R-0	M3GA 47-0 RAYBESTOS REBUILD KIT	11lbs
M3GA-47R-1	M3GA 47-1 RAYBESTOS REBUILD KIT	13lbs
M3GA-47R-2	M3GA 47-2 RAYBESTOS REBUILD KIT	18lbs
M3GA-47R-2B	M3GA 47-2 RAYBESTOS REBUILD KIT	18lbs
M3GA-47R-3E	M3GA 47-3 RAYBESTOS REBUILD KIT	24lbs
M3GA-47R-3H	M3GA 47-3 RAYBESTOS REBUILD KIT	24lbs
M3GA-47R-3L	M3GA 47-3 RAYBESTOS REBUILD KIT	24lbs

M3GA-48-0	M3GA 48RE ALTO CLUTCHES & STEELS	11lbs
M3GA-48-1	M3GA 48RE ALTO CLUTCHES, STEELS, PP	13lbs
M3GA-48-2	M3GA 48-2 ALTO REBUILD KIT	18lbs
M3GA-48-2B	M3GA 48-2B ALTO REBUILD KIT	18lbs
M3GA-48-3	MEGA 48-3 RE/RH ALTO REBUILD KIT	24lbs
M3GA-48R-0	M3GA 48-0 RAYBESTOS REBUILD KIT	24lbs
M3GA-48R-1	M3GA 48-1 RAYBESTOS REBUILD KIT	11lbs

M3GA-48R-2	M3GA 48-2 RAYBESTOS REBUILD KIT	13lbs
M3GA-48R-3	M3GA 48-3 RAYBESTOS REBUILD KIT	18lbs
M3GA-48R-3B	M3GA 48-3B RAYBESTOS REBUILD KIT	24lbs
M3GA-JR-48R-2	M3GA JR 48-2 RAYBESTOS REBUILD KIT	15lbs

M3GA-68-1	68 OEM UPGRADE CLT/STEEL KIT	17lbs
M3GA-68-2	68 OEM UPGRADED REBUILD KIT	22lbs
M3GA-68-4-G	68 M3GA KIT, GRAY VB,REQ. DRUM	28lbs
M3GA-68-4-W	68 M3GA KIT, WHITE VB,REQ. DRUM	28lbs
M3GA-68-5-G	68RFE-5 OEM UPGRADED REBUILD KIT	28lbs
M3GA-68-5-W	68RFE-5 OEM UPGRADED REBUILD KIT	28lbs
68-M3GA DRUM	68 M3GA DRUM ASSEMBLY	25lbs

SunCoast DODGE ACCESSORIES

SunCoast's transmission accessory section is packed with quality designed and manufactured parts. Whether sled pulling, drag racing, or hauling heavy loads SunCoast has a variety of parts to outfit any transmission to ensure dependability when it matters most.

618-BFP: SFI approved heavy-duty billet steel flex plate. Designed and machined in-house (NOT STAMPED).



68RFE-BFP: SFI approved heavy-duty billet steel flex plate. Designed and machined in-house (NOT STAMPED).



SFI-48RE-1: The SunCoast "BadAss Transmission Jacket" is a custom tailored jacket that fits to the profile of the transmission case. SFI foundation has given this jacket their "4.1" certification which allows them to meet all NHRDA, NHRA, IHRA, NADM rules and regulations. Attachment pieces for this multipur-

pose "BadAss Transmission Jacket" will allow the vehicle to pass tech for both, drag racing, and sled pulling. SunCoast designed and made the jacket in the U.S. with the best, most proven heavy-duty/efficient safety materials available. The jacket features heavy-duty urethane coated nylon, multiple Kevlar® layers, and formulas to protect against catastrophic transmission failure. The jacket was designed by transmission specialists for ultimate driver safety.



618-HSX: Standard size 300M billet input shaft

618-27: SunCoast Proprietary 27 spline input shaft (requires custom torque converter)

618-OM3GA-KIT: SunCoast Proprietary 25 spline input shaft, complete custom pump, and stator support. Requires custom torque converter.

618-BOS: Designed for higher horsepower/torque engines, this performance product has been tested in excess of 1,400 ft./lbs. of torque. Shaft is machined from 300M material then heat treated for torsional strength and precision ground on all critical diameters.



618-SK: "Stubby Kit" This kit allows your 2wd transmission to have a billet output shaft. SunCoast installs a specific bearing, which allows for a slip yoke (400 spline Mark Williams).

K123900SH: Billet steel front drum & extra large billet aluminum piston. This billet steel drum is made from AIAI/SAE 1040-1045 medium-carbon machinery steel. It is stronger, more reliable, and safer than the OEM cast iron drum and is also longer lasting than the aluminum drum - ideal for street use.

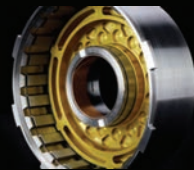

- Will hold up to 6 friction plates versus

4 in the OEM unit.

- 55% more piston apply surface area. This results in double the clamping force needed in third gear.
- Engineered with dual oil apply passages for even piston apply.
- Kit comes with a precision CNC machined billet aluminum piston.



68-M3GA DRUM: The SunCoast complete rotating assembly offers you the ultimate in performance and durability for your 6.7L Cummins. The drum is highly modified with springs and orifices to correct the balance oil system in the overdrive circuit. Not only are the clutches larger, but the piston has been increased, as well. SunCoast also had to design the pressure

plates not only to be larger in diameter for increased clutch area, but also for the strength.

- 51% more surface apply area than a stock 68RFE drum
- Oversized double sided SunCoast designed clutches are housed in patented billet inner and outer "M3GA" drum setup to utilize every square inch of available real estate inside of the transmission.

VALVE BODIES: The valve body controls gear selection, line pressure (clamping force), line rise (meeting torque demand), converter mode, flow and pressure, along with shift timing and quality. SunCoast valve-bodies address all of these areas to enhance transmission operation and durability. The SunCoast valve bodies allow for crisper shifts, enhanced converter operation, cooler operating temperatures, and increased lube flow. Full-time converter feed assures lube flow while in the park position and under high throttle conditions. Torque converter clutch lock-up can be achieved in all forward gears when used in conjunction with a controller. This feature is desirable for optimum exhaust brake opera-

tion. SunCoast offers a choice of valve body calibrations to fit any application.

E-618-VB: SunCoast has separated the 47/48RE electronic automatic transmission from yesterday's 47RH hydro-mechanical automatic transmission with some never before seen abilities. SunCoast, with its speed and simplicity in tuning, has done what may have seemed like a complex or impossible task in the past. The TCU can use these inputs as well as torque converter speed, engine speed, wheel speeds, traction control parameters, electronic throttle position, fluid temperature, engine temperature, brake pedal actuation, forward and lateral acceleration as well as several other parameters. The TCU can also utilize manual shifting operation and provide altered transmission behavior for special conditions (road race, drag race, dyno, snow, towing, etc.). The only thing required to make a transmission work is a TPS signal, power, and ground.

6188203-M: The valve body controls the shifting of the transmission. The computer controls when the valve body shifts the transmission. SunCoast's manual valve body will

give full control when the transmission shifts and with no delay as the electronic types do. Shifts will be precise, quicker, and firmer than any electric shifted valve body. SunCoast can build manual valve bodies to have the standard forward shift pattern.

618829902-RM: SunCoast's reverse manual valve body will give full control when the transmission shifts and with no delay as the electronic types do. Shifts will be precise, quicker, and firmer than any electric shifted valve body. What's the need for a reverse pat-

tern? There is no need to worry about slamming the shifter towards neutral or reverse.

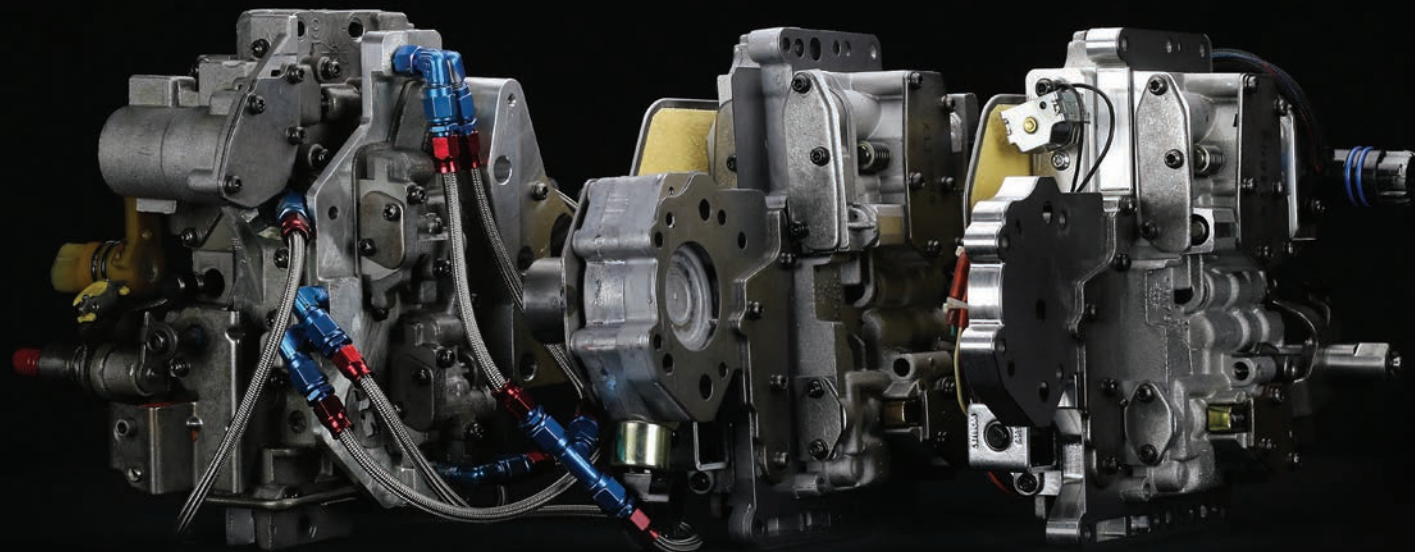

PART NUMBERDESCRIPTION WEIGHT

47/48 VB COMPONENTS

618-GK	GOVERNOR PRESSURE SOLENOID	3lbs
618-WK-1	94-95 SHIFT SOLENOID	1lb
618-WK-2	96-99 SHIFT SOLENOID	1lb
618-WK-3	2000 SHIFT SOLENOID	1lb
SK-47RE	TF DIESEL SHIFT KIT	2lb

47/48RE BILLET PARTS

61822825HP	BILLET BAND KIT W/ STRUT & ANCHOR	4lbs
61822841HD	4 RING ACCUMULATOR PISTON	1lb
618-25M	618 OM3GA 25 SPL SHAFT AND HUB	20lbs
618-27M	618 27 SPLINE INPUT SHAFT/HUB	20lbs
618400	2X STUBBY OUTPUT SHAFT	8lbs
618-44	618 4.4 BILLET BAND LEVER	1lb
618-BA	BAND ANCHOR	1lb
618-BIN	300M INTERMEDIATE SHAFT	6lbs
618-BOS-4X	4X4 BILLET OUTPUT SHAFT	6lbs
618-BOS-RH	4X4 BILLET OUTPUT SHAFT	6lbs
618-BS	BILLET BAND STRUT	1lb
618-BSK	BILLET STRUT AND ANCHOR KIT	2lbs
618-BVR	BOOST VALVE RETAINER	1lb
618-DBP	DIRECT BILLET PISTON	2lbs
618-FBP-1	FWD BILLET PISTON .815	2lbs
618-FBP-2	FWD BILLET PISTON .840	2lbs
618-HSX	BILLET INPUT SHAFT	6lbs

618-OM3GA-PG	OM3GA PUMP GEAR SET	16lbs
618-OM3GA-PUMP	618 PUMP FOR OM3GA SHAFT	15lbs
618-REVENT	FRONT VENT RELOCATE	11lbs
618-SH	STUBBY HOUSING	7lbs
618-SHM	STUBBY HOUSING MACHINED	12lbs
618-SK	618 STUBBY KIT	23lbs
618-UDS	UNIVERSAL DIPSTICK	5lbs
K123900SH	618 BILLET DRUM	11lbs
618-BOS-29K	29 SPLINE OUTPUT SHAFT & T CASE GASKET ..	12lbs
618-BOS-29	29 SPLINE OUTPUT SHAFT	12lbs

47RE/48RE VALVE BODY

6188203	03 - 47RE VALVE BODY	18lbs
6188203-M	03 MANUAL SHIFT VALVE BODY	18lbs
6188203-RM	03 618 REVERSE MANUAL VALVE BODY	18lbs
6188203-RM-TB	03 618 REVERSE MANUAL VALVE BODY TB	18lbs
618820407-M	2000+ 618 MANUAL VALVE BODY	18lbs
618820407-RM	2000+ 618 REVERSE MANUAL VALVE BODY	18lbs
6188248	48RE VALVE BODY	18lbs
61882-487	48RE VB WITH NEW UPG	18lbs
61882-48702	47RE VB W/ELT 03-07	18lbs
61882-48703	47RE VB W/ELT 03-07	18lbs
61882-4879699	48RE VB W/ELT 96-99	18lbs
61882-4879902	47RE VB W/ELT 99-02	18lbs
61882-48R	STK CAL REBUILT VB	18lbs
6188248-RM	48RE VALVE BODY	18lbs
618828990	37RH VALVE BODY	18lbs

618829495	94-95 VALVE BODY	18lbs
618829495-M	48 MANUAL VALVE BODY 94-95	18lbs
618829495-RM	618 REV MANUAL VALVE BODY 94-95	18lbs
618829495-RM-TB	618 REV MANUAL TRANS BRAKE 94-95	18lbs
618829698	96-98 VALVE BODY	18lbs
618829698-M	618 MANUAL VALVE BODY 96-98	18lbs
618829698-M-TB	618 MANUAL TRANS BRAKE 96-98	18lbs
618829698-RM	618 REV MANUAL VALVE BODY 96-98	18lbs
618829902	618 VALVE BODY 99-02	18lbs
618829902-M	618 MANUAL VALVE BODY 99-02	18lbs
618829902-M-TB	618 MANUAL TRANS BRAKE 99-02	18lbs
618829902-RM	618 REV MANUAL VALVE BODY 99-02	18lbs
618829902-TB	618 TRANSBRAKE VALVE BODY 99-02	18lbs
6188299495-TB	618 TRANSBRAKE VALVE BODY 94-95	18lbs
E618-VB	618 SC ELECTRIC VALVE BODY	18lbs
E618-VB-TB	618 SC 618 ELECTRIC TRANS BRAKE VB	18lbs

48RE VB COMPONENTS

SK-48RE	DIESEL & V10 03-06	2lbs
----------------------	--------------------------	------

68RFE BILLET PARTS

68-2CP	68 2C BILLET PISTON	2lbs
68-961JR	68RFE SC-961 JR BILLET DRUM	22lbs
68-961-M3GA	M3GA 961 & 554 DRUM W/P/PLATES	25lbs
68-BIS	68RFE M3GA BILLET INPUT SHAFT	5lbs
68-ICH	68RFE INPUT CLUTCH HUB	10lbs
68-LRS	68RFE UPGRADED L/R SPRAG	6lbs

M3GA-4C-978A	68RFE M3GA 4C SNAP RING	2lbs
---------------------------	-------------------------------	------

68RFE COMPONENTS

515490	68RFE SPIN ON FILTER	1lbs
515492	45RFE/545RFE/68RFE FILTER	2lbs
68-LDS	68RFE LOCKING DIP STICK	1lbs
68-PRV	68FFE M3GA PR VALVE, REQ A PLATE	1lbs
68-PRVBP-11E	68RFE M3GA PR VALVE AND VB PLATE	3lbs
68-PRVBP-7E	68RFE M3GA PR VALVE AND VB PLATE	3lbs
68-VBP-11E	68RFE VB PLATE REV 11E	1lbs
68-VBP-7E	68RFE VB PLATE REV 7E	1lbs
D44914B	68RFE FRONT PUMP COVER	2lbs

47/48RE GASKET SET

TF22002E	47RE GASKET AND SEAL KIT	5lbs
TF22002GW	48RE KIT	6lbs

68RFE GASKET SET

TF72002C	68RFE GASKET KIT	4lbs
-----------------------	------------------------	------

68RFE VB COMPONENTS

45RFE-HD2	45RFE/545RFE/68RFE	3lbs
------------------------	--------------------------	------

DODGE ENGINE PARTS

59-AT-4	5.9L AIR TEMP SENSOR	1lbs
59-AT-5	5.9L AIR TEMP SENSOR	1lbs
67-AT-4	6.7L AIR TEMP SENSOR	1Lbs

67-AT-5	6.7L AIR TEMP SENSOR	1Lbs
67-AT-5A	6.7L AIR TEMP SENSOR (ALUM)	1Lbs
67-MAF-4	6.7L MASS AIR FLOW S	1Lbs
67-MAF-5	6.7L MASS AIR FLOW S	1Lbs
67-MAF-5A	6.7L MASS AIR FLOW S	1Lbs
SC-59-AT-1	SC 5.9L 4" AT STEEL	1Lbs
SC-59-AT-2	SC 5.9L 5" AT STEEL	1Lbs
SC-59-AT-3	SC 5.9L 4" AT ALUM	1Lbs
SC-59-AT-4	SC 5.9L 5" AT ALUM	1Lbs
SC-59-AT-5	SC 5.9L 4" AT SS	1Lbs
SC-59-AT-6	SC 5.9L 5" AT SS	1Lbs
SC-67-AT-1	SC 6.7 4" AT STEEL	1Lbs
SC-67-AT-2	SC 6.7 5" AT STEEL	1Lbs
SC-67-AT-3	SC 6.7 4" AT ALUM	1Lbs
SC-67-AT-4	SC 6.7 5" AT ALUM	1Lbs
SC-67-AT-5	SC 6.7 4" AT SS	1Lbs
SC-67-AT-6	SC 6.7 5" AT SS	1Lbs
SC-67-MAF-1	SC 6.7 4" STEEL	1Lbs
SC-67-MAF-2	SC 6.7 5" STEEL	1Lbs
SC-67-MAF-3	SC 6.7 4" ALUM	1Lbs
SC-67-MAF-4	SC 6.7 5" ALUM	1Lbs
SC-67-MAF-5	SC 6.7 4" SS	1Lbs
SC-67-MAF-6	SC 6.7 5" SS	1Lbs
SC-67-VCB-1	SC 6.7L VALVE COVER BRACKET (PS)	2Lbs
SC-67-VCB-2	SC 6.7L VALVE COVER BRACKET (DS)	2Lbs

DODGE TRANSMISSION PANS

MAG-68RFE	68RFE MAG-HYTEC PAN	19lbs
MAG-68RFE-SC	68RFE MAG-HYTEC PAN WITH SC LOGO	19lbs
MAG-727D	47/48 MAG-HYTEC PAN	19lbs
MAG-727DD	47/48 DD MAG-HYTEC PAN	19lbs

DODGE SFI PRODUCTS

618-BFP	618 BILLET SFI APPROVED FLEXPLATE	18lbs
68RFE-BFP	68RFE BILLET SFI APPROVED FLEXPLATE	18lbs
SFI-47RE-1	SFI 4.1 COVERS GEARTRAIN	7lbs
SFI-4847-2	SFI 4.1 BELLY COMING SOON	7lbs
SFI-4847-3	SFI 4.1 BELLHOUSING COMING SOON	7lbs
SFI-48RE-1	SFI 4.1 COVERS GEARTRAIN	7lbs
SFI-68RFE-1	SFI 4.1 COVERS GEARTRAIN	7lbs
SFI-68RFE-2	SFI 4.1 BELLY COMING SOON	7lbs
SFI-68RFE-3	SFI 4.1 BELLHOUSING COMING SOON	7lbs

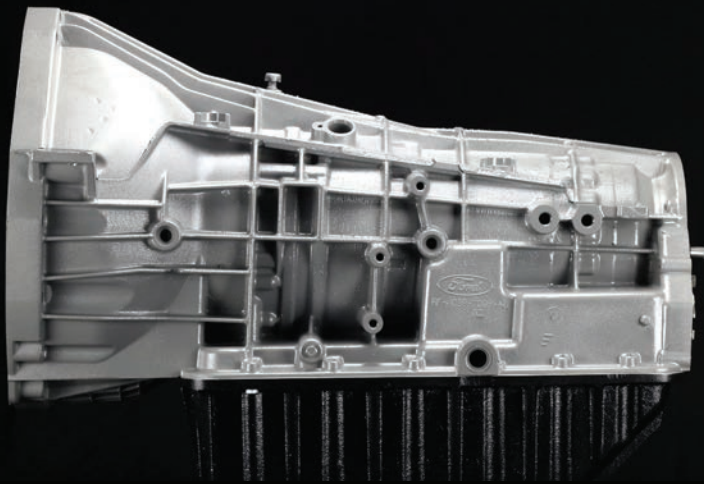

FORD TRANSMISSIONS E40D | 4R100 | 5R110 | 6R140

OEM Transmission clutches fail in high stress applications due to excessive heat. This heat promotes and accelerates wear and tear that ultimately leads to premature catastrophic failure. SunCoast's Ford transmissions are engineered and built to the highest standards. These transmissions feature proven, better than OEM, aftermarket friction materials, and steel technologies that will hold up in almost any situation. SunCoast's increased clutch quantities are complimented with a TransGo® valve body re-calibration kit that gives the transmission superior

shift quality and pressure. Mild to wild, SunCoast can suit any need.

- **Standard built transmission: 3 year unlimited mile warranty**
- **Competition transmission: 1 year unlimited mile warranty**

The SunCoast transmission includes increased clutch count with high-energy friction materials of choice (Alto® or Raybestos®), treated steels and also features:

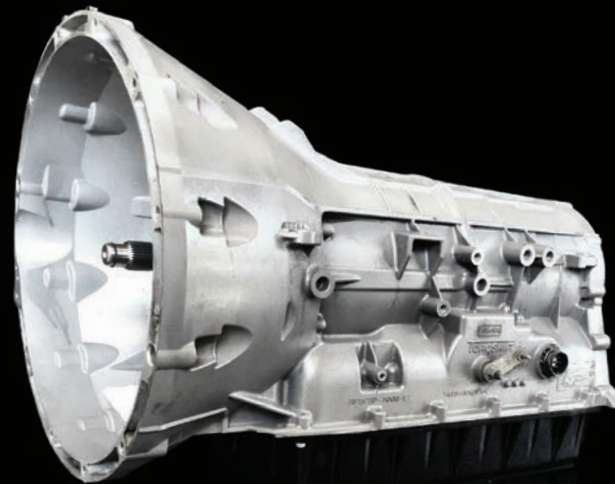

1990-1997 E40D

- 1990-1994
- 1990-1994
- 1995-1997
- 1995-1997

- E40D 2wd
- E40D 4wd
- E40D 2wd
- E40D 4wd



1999-2003 4R100

- 1999-2003
- 1999-2003
- 1999-2003
- 1999-2003

- 4R100 2wd
- 4R100 2wd PTO
- 4R100 4wd
- 4R100 4wd PTO

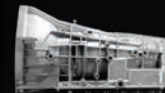

2003-2010 5R110

- 2003-2004
- 2003-2004
- 2003-2004
- 2003-2004
- 2005-2007
- 2005-2007
- 2008-2010
- 2008-2010

- 5R110 2wd
- 5R110 2wd PTO
- 5R110 4wd
- 5R110 4wd PTO
- 5R110 2wd
- 5R110 4wd
- 5R110 2wd
- 5R110 4wd



2011-2015 6R140

- 2011-2015
- 2011-2015

- PLSD-6R140-2X
- PLSD-6R140-4X

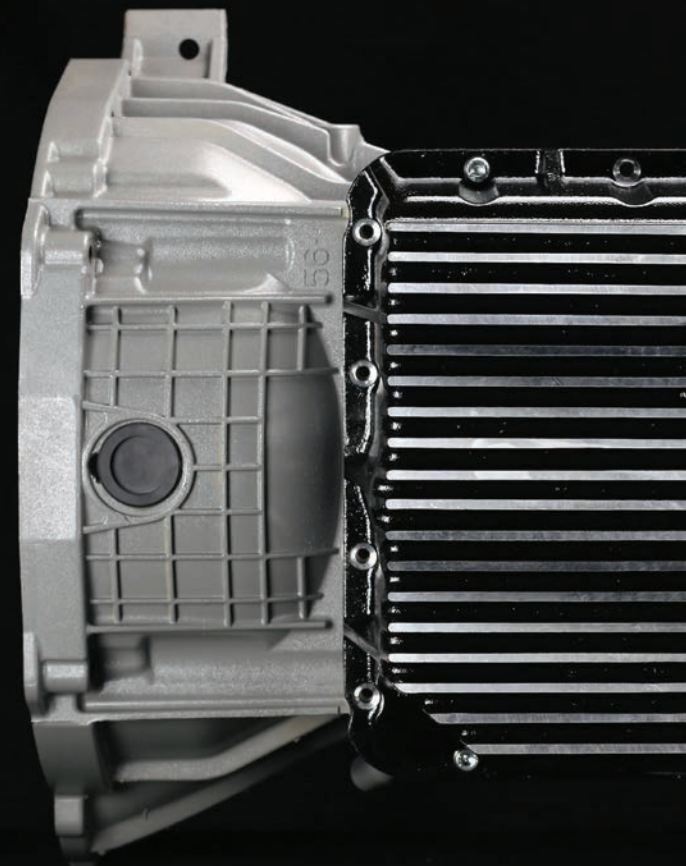



FORD E40D | 4R100 | 5R110

SunCoast's Ford series torque converters use a larger than stock, triple clutch design for more holding power. Its forged billet steel covers provide added strength while also providing better heat distribution than stock type converters. Custom billet stators are available for increased torque multiplication and efficiency. These converters work for stock to high power applications for higher torque multiplication and better drivability.

- **Designed and manufactured in house**
- **Tig welding to reinforce furnace brazed fins**
- **Signature trapazoid clutch teeth (no round tabs)**
- **Forged billet cover**
- **Piston and stators machined in house**
- **Pressure tested welds/spun balanced**

PART NUMBER	DESCRIPTION	WEIGHT
4R100-SD265-3D	HIGH STALL GAS/DIESEL CONVERTER	77lbs
4R100-SD36-3D	4R100 LOW STALL CONVERTER	77lbs
4R100-SD44-3D	LOW STALL CUMMINS CONVERTER	77lbs
5R110-25-3D-6	03-07 HD 13" RACE/TOW CONVERTER	77lbs
5R110-25-3D-8	08-10 HD 13" RACE/TOW CONVERTER	77lbs
5R110-64-3D	03-07 LOW STALL CONVERTER	77lbs
5R110-64-3D-8	08-10 LOW STALL CONVERTER	77lbs
5R110-65-3D	03-07 MEDIUM STALL CONVERTER	77lbs
BAC-5R110-21-3D	BAD ASS CONVERTER	80lbs

FORD REBUILD KITS

SunCoast's Ford series rebuild kits cover all years from 1989-2015 (kit part number dependent upon year). These kits utilize the latest proven friction materials and steel technology from industry leading companies such as Alto®, Exedy®, and Raybestos®. SunCoast works directly with these companies to design and manufacture proprietary exclusive SunCoast product lines, giving the end user uncompromised quality throughout the entire transmission. SunCoast has designed these kits in-house to exact specifications for many intents, including but not limited to towing, sled pulling, racing or having a vehicle to get from point A to point B. Along with these kits, SunCoast has a full line of billet single and triple disc torque converters ranging from 1800 stall to approximately 3000 RPM (manufactured in-house), billet input/output shaft options, SunCoast designed E-Clutch damper (patent pending) billet steel drums, low and reverse hubs (year dependent), SunCoast 5R110 limit valve, SFI approved flex plates, SFI approved transmission jackets and much more.

IRON-0305-1

OD CLUTCH PAC

- (2) pressure plates
- (4) koleen steels
- (5) frictions
- (1) Proprietary SunCoast OD piston

INT CLUTCH PAC

- (1) stepped pressure plate
- (5) Koleen steels
- (5) 96 tooth double sided frictions
- (5) 24 tooth INT double sided frictions

FWD: 1ST DESIGN

- (1) stepped pressure plate
- (5) Koleen steels
- (5) Double sided frictions

FWD: 2ND DESIGN

- (1) stepped pressure plate
- (5) Koleen steels
- (5) 2nd design double sided frictions
- (1) .076 snap ring

DIRECT PAC

- 1 Flat Apply Plate
- (1) stepped Pressure plate
- (6) koleen steels
- (6) double sided frictions

- (1) Proprietary Suncost direct piston
- (1) .076 snap ring

LOW/REVERSE

- (6) koleen steels
- (6) double sided frictions

IRON-0305-2

INCLUDES ALL OF IRON-0305-1 +

5R110W-SK

TransGo® - 5R110W Transmission shift kit
TransGo® SK 5R110W Reduces corrects or prevents case lug blow out, runaway reverse pressure, slips or no reverse and neutrals at stop. This 5R110W transmission valve body kit is designed for installation installed during transmission rebuild.

IRON-0305-3

INCLUDES ALL OF IRON-0305-1, 0305-2 +

T136002A

Complete proprietary SunCoast gasket and sealing kit

IRON-0608-1

OD CLUTCH PAC

- (2) Pressure plates
- (4) Koleen steels
- (5) Frictions
- (1) Proprietary SunCoast OD piston

INT CLUCH PAC

- (1) Stepped pressure plate
- (5) Koleen steels
- (5) 96 tooth double sided frictions
- (5) 24 tooth INT double sided frictions

FWD: 2ND DESIGN

- (1) Stepped pressure plate
- (5) Koleen steels
- (5) 2nd design double sided frictions
- (1) .076 snap ring

DIRECT PAC

- (1) Flat Apply Plate
- (1) Stepped Pressure plate
- (6) Koleen steels

- (6) Double sided frictions
- (1) Proprietary SunCoast direct piston
- (1) .076 snap ring

LOW/REVERSE

- (6) Koleen steels
- (6) Double sided frictions

IRON-0608-2

INCLUDES ALL OF IRON-0608-1 +

5R110W-SK

TransGo® ® - 5R110W Transmission shift kit
TransGo® SK 5R110W Reduces Corrects or Prevents case lug blow out, runaway reverse pressure, slips or no reverse and neutrals at stop. This 5R110W transmission valve body kit is designed for installation installed during transmission rebuild.

IRON-0608-3

INCLUDES ALL OF IRON-0608-1, 0608-2 +

T136002A

Complete proprietary SunCoast gasket and sealing kit

IRON-0910-1

OD CLUTCH PAC

- (2) Pressure plates
- (4) Koleen steels
- (5) Frictions
- (1) Proprietary SunCoast OD piston

INT CLUCH PAC

- (1) Stepped pressure plate
- (5) Koleen steels
- (5) 96 tooth double sided frictions
- (5) 24 tooth INT double sided frictions

FWD: 2ND DESIGN

- (1) Stepped pressure plate
- (5) Koleen steels
- (5) 2nd design double sided frictions
- (1) .076 snap ring

DIRECT PAC

- (1) Flat Apply Plate
- (1) Stepped Pressure plate
- (6) Koleen steels
- (6) Double sided frictions
- (1) Proprietary SunCoast direct piston
- (1) .076 snap ring

IRON-0910-2

INCLUDES ALL OF IRON-0910-1 +

5R110W-SK

TransGo® ® - 5R110W Transmission shift kit
TransGo® SK 5R110W reduces, corrects or prevents case lug blow out, runaway reverse pressure, slips or no-reverse and neutrals at stop. This 5R110W transmission valve body kit is designed for installation installed during transmission rebuild.

IRON-0910-3

INCLUDES ALL OF IRON-0910-1, 0910-2 +

T136002A

Complete proprietary SunCoast gasket and sealing kit

IRON-6R140-1E

A/FWD

- (5) Double sided frictions
- (5) Steels

B/DIRECT

- (5) Double sided frictions
- (5) Steels

C/INT

- (6) Double sided frictions
- (6) Steels

D/LOW&REVERSE

- (5) Double sided segmented frictions
- (5) Steels

E CLUTCH

- (8) Double sided Proprietary SunCoast frictions
- (8) Steels

IRON-6R140-2E

INCLUDES IRON-6R140-1E + 6R140-SC DAMPER

(1) 6R140 SunCoast E clutch dampr assembly

IRON-6R140-3E

INCLUDES IRON-6R140-2E +

T236002AW

SunCoast Gasket and Sealing kit

DISCLAIMER

Instructions are included in kit and phone support is available during normal business hours. ALL KITS ARE INTENDED FOR PROFESSIONAL INSTALLATION. Custom kits are available upon request. Parts included are manufactured or designed in house making it easier to tailor each kit to the needs of the customer and the potential of their vehicle.

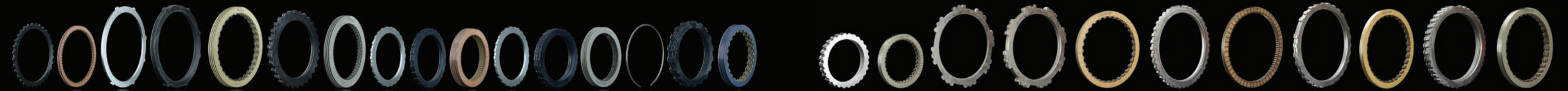

PART NUMBER DESCRIPTION WEIGHT

E4OD REBUILD KIT

026750W-E48995	E4OD REBUILD KIT 89-95.....	19lbs
026750W-E49698	E4OD REBUILD KIT 96-98.....	19lbs

4R100 REBUILD KITS

026750W	4R100 REBUILD KIT.....	17lbs
----------------	------------------------	-------

5R110 REBUILD KITS

IRON-0305-1	03-05 5R110 CLT KIT.....	26lbs
IRON-0305-1R	03-05 5R110 CLT KIT.....	26lbs
IRON-0305-2	03-05 5R KIT INCLUDE.....	27lbs
IRON-0305-2R	03-05 5R KIT WITH RA.....	27lbs
IRON-0305-3	03-05 IRON PAC WITH.....	30lbs
IRON-0305-3R	03-05 IRON PAC WITH.....	30lbs
IRON-0608-1	06-08 5R110 CLUTCHES.....	26lbs
IRON-0608-1R	06-08 5R110 CLUTCHES.....	26lbs
IRON-0608-2	06-08 5R110 CLUTCH.....	27lbs
IRON-0608-2R	06-08 5R KIT WITH RA.....	27lbs
IRON-0608-3	06-08 IRON PAC WITH.....	30lbs
IRON-0608-3R	06-08 IRON PAC WITH.....	30lbs
IRON-0910-1	09-10 5R CLT KIT.....	19lbs
IRON-0910-1R	09-10 5R CLT KIT RAY.....	19lbs
IRON-0910-2	09-10 5R CLT/SK KIT.....	20lbs
IRON-0910-2R	09-10 5R KIT WITH RA.....	20lbs
IRON-0910-3	09-10 IRON PAC WITH.....	22lbs

IRON-0910-3R	09-10 IRON PAC WITH.....	22lbs
---------------------	--------------------------	-------

6R140 REBUILD KITS

IRON-6R140-1E	6R140 CLUTCH/STEELS KIT.....	15lbs
IRON-6R140-1R	6R140 CLUTCH/STEELS KIT.....	15lbs
IRON-6R140-2E	6R140 CLUTCH/STEEL KIT W/SC HUB.....	26lbs
IRON-6R140-2R	6R140 CLUTCH/STEEL KIT W/SC HUB.....	26lbs
IRON-6R140-3E	6R140 CL/ST KIT W/SC HUB AND GASKET.....	28lbs
IRON-6R140-3R	6R140 CL/ST KIT W/SC HUB AND GASKET.....	28lbs
IRON-6R140-OEM	6R140 MASTER KIT W/PISTONS.....	28lbs

**SUPERIOR
PERFORMANCE
IS NO FLUKE.
ESTABLISH THE
DOMINANCE.**

SUNCOAST FORD ACCESSORIES

SunCoast's Ford transmission accessory section is packed with quality designed and manufactured parts. Whether sled pulling, drag racing, or hauling heavy loads, SunCoast has a variety of parts to outfit any transmission to ensure dependability when it matters most.

E4100-BFWD



- Machined from 4140 billet steel
- Eliminates input spline stripping
- Increases clutch frictions from 4 to 6

SFI APPROVED FLEX PLATES | 60-BFP



64-BFP: The SunCoast billet flex plate is the perfect addition to its torque converters and transmissions. Its SFI Spec 29.3 approved

Ford flex plates incorporate the crank flange into our design. Perfect for heavy duty towing, street driving, drag racing, and sled pulling.

FORD 5R110/4R100 INPUT SHAFT 300 M



- Made from 300 M alloy steel for maximum yield strength.
- For high torque diesel & off-road applications.
- Heat treated & precision ground.
- 30/31 spline count.
- Shaft is rated to 2500 ft/lbs. of torque.
- 100% drop-in assembly.

4R36743: With SunCoast Dual Load Center Support, the load is now shared with added bronze bearing at front of hub. This stabilizes the load and stops point loading. It reduces bearing failure while maintaining im-



proved gear train alignment.

4R100CC4 | 4R100CC4-PTO: This drum doubles the friction element in the coast drum and fixes the common problem of the retaining ring dislodging and damaging the transmission. This drum comes with 4 new frictions, 4 steels, CNC machined pressure plate, and snap ring.



- Deep high-capacity sump for maximum cooling
- Magnetic drain plug
- 303 hardware except allen head cap screws are zinc plated
- 1/8 NPT temperature sender port
- Finned aircraft aluminum construction
- Requires only three allen key wrenches (included) for installation and service
- O-rings require no gaskets or sealants*

SFI-5R4R-1: The SunCoast “BadAss Transmission Jacket” is a custom tailored jacket that fits to the profile of the transmission case. SFI foundation has given this jacket their “4.1” certification which allows them to meet all NHRDA, NHRA, IHRA, NADM rules and regulations. Attachment pieces for this multipurpose “BadAss Transmission jacket” will allow the vehicle to pass tech for both, drag racing, and sled pulling. SunCoast designed and made the jacket in the U.S. with the best, most proven heavy-duty/efficient safety materials available. The jacket features heavy-duty urethane coated nylon, multiple Kevlar® layers, and formulas to protect against catastrophic transmission failure. The jacket was designed

by transmission specialists for ultimate driver safety.

UDS-LOCKING DIPSTICK:

SC-6R140-ECD: 6R140 E clutch Damper - One of the key problems associated with the Ford 6R140 Transmission is a noticeable substantial “squawk” noise which occurs during the oncoming 4th gear clutch during the 3-4 gear exchange. This noise becomes much more prominent when aftermarket friction materials are used inside the transmission for added holding capacity. The SunCoast patent pending E-Clutch Damper is the solution



to this problem. Using Sound Reduction/Absorption Technology, the E-Clutch damper dissipates the unwanted squawk allowing for a clean, crisp, and silent gear exchange.

PART NUMBERDESCRIPTION WEIGHT

4R100 VB COMPONENTS

4R100-HD2	TUGGER4R100 REBUILD KIT	4lbs
96948-01K427 LINE VALVE	1lbs
96948-05K500 LINE VALVE	1lbs
E4-VL-23	2-3 SHIFT VALVE	1lbs

4R100 COMPONENTS

3C3Z7A095AA	TRANSMISSION OIL COOLER	9lbs
4R100CC4	COAST CLUTCH FRICTIONS	6lbs
4R100CC4PTO	COAST CLUTCH FRICTIONS PTO	8lbs
4R36743	DUAL LOAD CENTER SUPPORT	9lbs
4RBPE	4R100 BYPASS ELIMINATOR	1lbs
515044	4R100/E4OD 4WD FILTER	3lbs

5R110 BILLET PARTS

5R-BIN	EARLY 5R BILLET INTERMEDIATE 96T	4lbs
5R-BIN-08	LATE 5R BILLET INTERMEDIATE 99T	4lbs
5R-BIS	5R BILLET INPUT SHAFT	7lbs
5R-LRH	5R BILLET LOW/REVERSE HUB	2lbs

5R110 COMPONENTS

515196	5R110 08-UP FILTER	1lbs
515577	5R110 03-07 FILTER	1lbs
5R110-FF-KIT	5R110 AUXILIARY FILTER KIT	7lbs
5R-LDS	5R110 LOCKING DIP STICK	1lbs

5R110 VB COMPONENTS

5R110W-SK	5R110 SHIFT KIT	2lbs
------------------------	-----------------------	------

6R140 COMPONENTS

126010	6R140 FILTER	2lbs
6R-LDS	6R140 LOCKING DIP ST	2lbs

E40D COMPONENTS

36010EA	E4OD 4X PAN FILTER	2lbs
4739	FORD COOLER W/O BYPASS	19lbs
E4-EXTOW	DUAL CENTER SUPPORT	9lbs

E4OD/4R BILLET PARTS

E4100-BFWD	E4/4R BILLET FORWARD DRUM	18lbs
E4100-BIN	E4/4R BILLET INTERMEDIATE SHAFT	8lbs
E4100-BOS	E4/4R 300M BILLET OUTPUT SHAFT	5lbs

FORD MAG PANS

MAG-5R110	03-07 5R110 MAG-HYTEC PAN	24lbs
MAG-5R110W	5R110 08-UP MAG-HYTEC PAN	24lbs
MAG-6R140	6R140 MAG-HYTEC PAN	24lbs
MAG-E4OD/4R100	E4OD/4R100 MAG-HYTEC PAN	24lbs

FORD SFI PRODUCTS

60-BFP	6.0L BILLET FLEX PLATE	19lbs
64-BFP	6.4L BILLET FLEX PLATE	19lbs
73-BFP	7.3L BILLET FLEX PLATE	19lbs

- SFI-5R4R-1 SFI 4.1 COVERS GEARTRAIN 9lbs
- SFI-5R4R-2 SFI 4.1 BELLY COMING SOON 9lbs
- SFI-5R4R-3 SFI 4.1 BELLY COMING SOON 9lbs

FORD GASKET KIT

- T36002EB E4OD/4R100 GASKET SET 3lbs
- T136002ASC 5R110 GASKET SET 3lbs
- T236002AW 6R140 GASKET SET 3lbs



SUNCOAST PREMIUM HAND SELECTED GASKETS & SEALS

SunCoast Premium Gaskets & Seals Kit includes everything needed in a transmission rebuilding kit for optimal performance. When it comes to transmission kits and components, Seal Aftermarket Products are dedicated to giving only the best quality component and technical support.

PRODUCT HIGHLIGHTS

- Improved check ball material
- Upgraded sealing rings
- Updated internal sealing material
- Upgraded with premium racing materials and critical components

GET MORE.

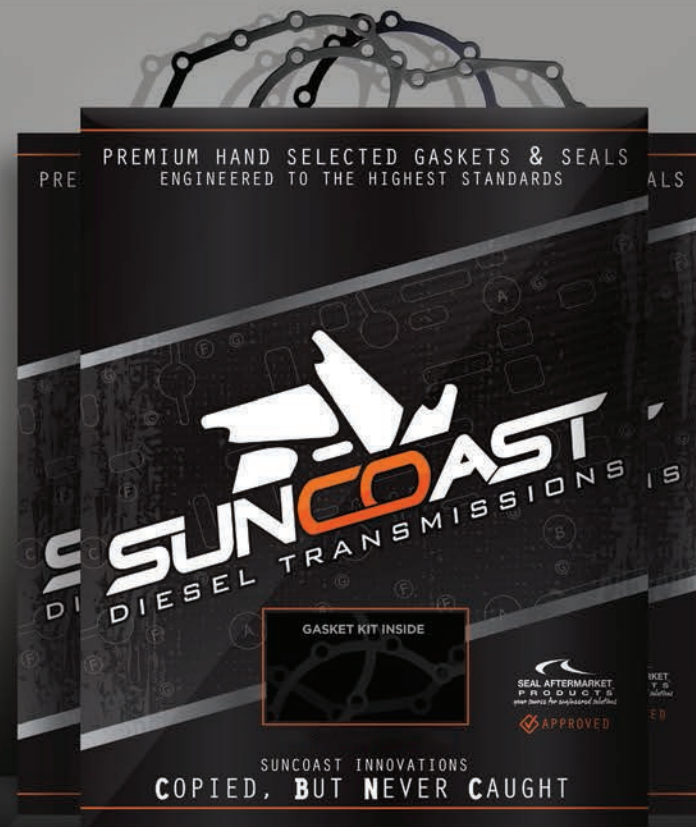

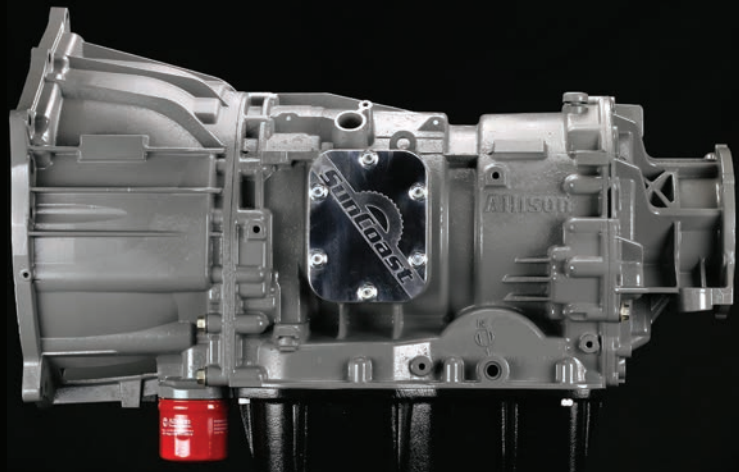

GM TRANSMISSIONS ALLISON 1000: 5 & 6 SPEED

The Allison 1000 transmission is more than suitable for stock applications, but it does have limitations. Once power exceeds 90-110 horsepower over stock the OEM clutch pacs begin to slip. Once slippage occurs, the transmission control module overrides the Allison and puts it into fail-safe mode, often referred to as "Limp Mode." Once the Allison reaches this state it begins to limp easier and easier. Luckily, SunCoast has the solution. SunCoast's Allison 1000 series transmissions are designed and engineered to be the most dependable, heavy-duty transmission option on the market. SunCoast's Allison transmis-

sions are proven to be more durable and dependable in any situation: street, sled pulling, towing or drag racing (transmission options may vary). Built with the best possible Allison parts on the market, these units can hold in excess of 1900 RWHP (with correct supporting hard parts).

STANDARD FEATURES:

- **Upgraded BST valve***
- **Recalibrated valve body***
- **High-energy C1, C2, C3, and C4 clutches and steels***
- **3 year unlimited mileage warranty (non competition transmission)**

* TransGo® Valve-body re-calibration kit, lock-up boost valve

* Multiple friction/steel options are available upon request such as Alto® and Raybestos®

OPTIONAL FEATURES:

- **Billet triple disc torque converter (built in-house)**
- **Mag hytec deep transmission pan**
- **Billet input/output/intermediate shafts**
- **Billet P2 planetary**
- **Billet C2 hub or sleeved hub.**

The SunCoast transmission includes increased clutch count with high-energy friction materials of choice (Alto® or Raybestos®), treated steels and also features:



Part Numbers:

ALLISON 1000 5 SPEED 2001-2005

A1-6VB-TCM-LB7-WT	01-03 LB7 5-6 SPEED
A1-6VB-TCM-LLY-WT	LLY 6 SPD CONVERSION
GMAX02-2X	01-02 GMAX TRANS 2X
GMAX02-4X	01-02 GMAX TRANS 4X
GMAX03-2X	03 GMAX TRANS 2X
GMAX03-4X	03 GMAX TRANS 4X
GMAX04-2X	04 GMAX TRANS 2X
GMAX04-4X	04 GMAX TRANS 4X
GMAX05-2X	05 GMAX TRANS 2X
GMAX05-4X	05 GMAX TRANS 4X



ALLISON 1000 5 SPEED 2006-2015

GMAX06-2X	06 GMAX TRANS 6SPD 2
GMAX06-4X	06 GMAX TRANS 6SPD 4
GMAX07-2X	06 GMAX TRANS 6SPD 2
GMAX07-4X	06 GMAX TRANS 6SPD
GMAX08-2X	08 GMAX TRANS 6SPD 2
GMAX08-4X	08 GMAX TRANS 6SPD 4
GMAX09-2X	09 GMAX TRANS 6SPD 2
GMAX09-4X	09 GMAX TRANS 6SPD 4
GMAX10-2X	10 GMAX TRANS 6SPD 2
GMAX10-4X	10 GMAX TRANS 6SPD 4
GMAX11-2X	11 GMAX TRANS 6SPD 2
GMAX11-4X	11 GMAX TRANS 6SPD 4

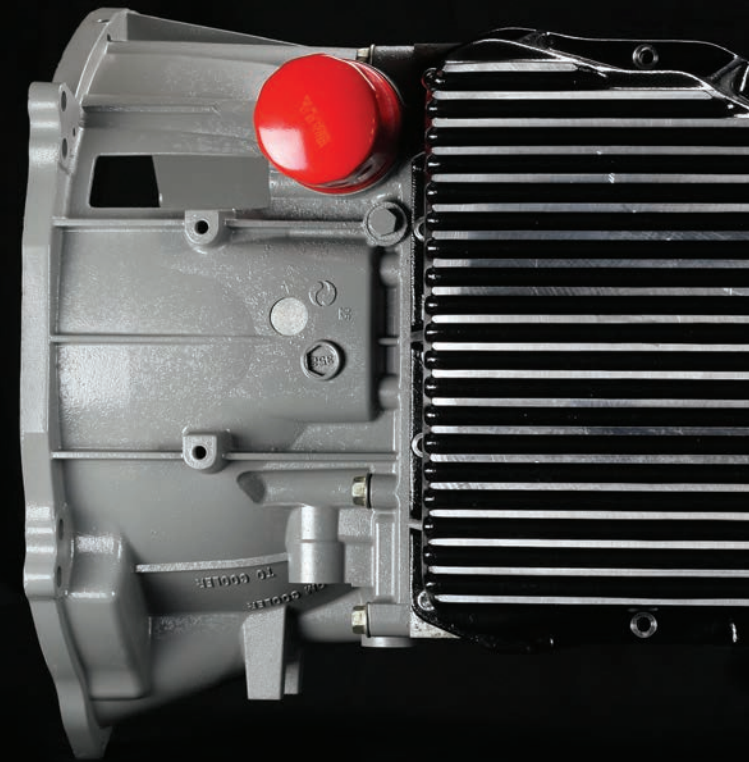



GM CONVERTERS

SunCoast Allison 1000 torque converters come in many varieties, from heavy hauling, sled pulling, drag racing, to daily driving. SunCoast designs and manufactures their torque converters in-house. Because of this, SunCoast can supply most any request in regards to stall or torque multiplication. All SunCoast triple disc converters are outfitted with a heavy-duty forged billet steel cover and give an unbeatable lock-up performance. The company's race series converter should be used in racing/pulling applications that require a higher "stall" RPM than a standard converter. Increased stall is usually needed in applications where a larger turbo or turbos have been installed and more RPM is required to get the turbo on boost while on the brakes (brake boosting).

These HD converters feature a billet stator and will resist damage to the stator section from excessive brake stalling (over 5 seconds).

FEATURES:

- Custom pump and turbine modifications (in-house)
- Tig welding to reinforce furnace brazed fins
- Proprietary converter clutches with trapezoid clutch teeth (no round tabs)
- CNC machine billet stators (1800-3000 RPM stall)
- 4140 turbine splines (heat treated depending on application)
- Billet steel and aluminum pistons
- Forged billet cover strength (proprietary Raybestos converter

clutch plates)

- Pressure rested welds/spun balanced on Stewart Warner Pro-Bal to Ensure highest quality
- 3 year unlimited mileage warranty

PART NUMBERDESCRIPTION WEIGHT

ALLISON CONVERTERS

GM-10531-3D	TRIPLE DISC HIGH STA	80lbs
GM-1053-3D	ALLISON 3D 2600 STAL	80lbs
GM-1054-3D	1900 STALL - VARIABLE- MEDIUM TURBO	80lbs
GM-1055-3D	2500 STALL BIG TURBOS CONVERTER	80lbs
GM-1056-3D	2000 STALL - TOW/DAILY DRIVER	80lbs
GM-1057-3D	1800 LOW STALL VELOCITY CONVERTER	80lbs
GM-1058-3D	2000-2300 STALL - DAILY DRIVER/RACE	80lbs





GM REBUILD KITS

SunCoast Allison series rebuild kits cover all years from 2001-2015 (kit part number dependent upon year). These kits utilize the latest proven friction materials and steel technology from industry leading companies such as Alto® and Raybestos®. SunCoast works directly with these companies to design and manufacture proprietary SunCoast exclusive product lines, giving the end user uncompromised quality throughout the entire transmission. SunCoast has designed these kits in-house to exact specifications for many intents, including but not limited to towing, sled pulling, racing or simply having a vehicle to get from point A to point B. Not included in this kit but highly recommended by SunCoast is a complete line of billet triple disc torque

converters ranging from 1800 stall to approximately 3000 RPM (manufactured in-house), 300M billet shaft options, custom valve body options ranging from 5-6 speed conversions and trans brake, SFI approved billet steel and aluminum flex-plates, SFI approved transmission jackets and much more.

KIT EXCLUSIVES

- **SunCoast Proprietary c3, c4 ALTO® Carbonite Frictions / RAYBESTOS® GPZ Frictions contain no center slots. These frictions utilize a waffle pattern in the material to help retain oil helping the clutch cool when not applied.**
- **Redesigned apply pistons with improved**

rubber compounds proven to hold more heat. This custom piston allows us to use a thicker spring apply plate which replaces the thin OEM one and in turn causes an uneven apply surface.

- **Custom apply plate that redirects fluid to better lubricate frictions from the inside out which lubes the entire friction rather than OEM style that lubricates from the center out leaving the inner half of the clutch burnt.**
- **C5 clutches are not included**
- **C5 clutches are optional and can be added to our kit upon request.**

GMAX 5-1 ALTO

C-1

- (1) Custom stepped apply plate,
- (8) external spline clutches
- (8) internal spline clutches
- (1) Custom C1 top plate.

C-2

- (1) Custom stepped apply plate
- (7) C-2 frictions
- (8) steels
- (1) wave plate

C-3

- (6) double sided waffle pattern frictions
- (5) steels
- (1) C3 Apply plate
- (1) c3 Pressure plate
- (1) p1 Carrier shim
- (1) .700 piston

C-4

- (6) internal spine single sided frictions
- (6) external spine single sided frictions
- (1) c4 apply plate
- (1) c4 pressure plate
- (1) .780 piston

GMAX 5-2 ALTO
IN ADDITION TO -1

Trans Go Lockup Boost Valve
Full TransGo® Shift kit®
Deep or shallow filter kit: Includes spin on, pan filter, SunCoast filter loc
Pump Shim and Tool

GMAX 5-3 ALTO

INCLUDES ALL OF -1,-2 CONTENTS PLUS

Full proprietary SunCoast Gasket and Sealing kit

GMAX 5-1 RAYBESTOS

C-1

- (1) Custom stepped apply plate,
- (8) external spline clutches
- (8) internal spline clutches
- (1) Custom C1 top plate.

C-2

- (1) stepped apply plate
- (7) Proprietary SunCoast GPZ friction
- (8) Proprietary SunCoast steels

C-3

- (6) double sided Proprietary SunCoast frictions

- (5) Proprietary SunCoast steels
- (1) C3 Apply plate
- (1) c3 Pressure plate
- (1) p1 Carrier shim
- (1) .700 piston

C-4

- (6) internal spine **double sided** Proprietary SunCoast frictions
- (5) Proprietary SunCoast steels
- (1) c4 apply plate
- (1) c4 pressure plate
- (1) .780 piston

GMAX 5-2 RAYBESTOS
IN ADDITION TO -1

Trans Go Lockup Boost Valve
Full TransGo® Shift kit®
Deep or shallow filter kit: Includes spin on, pan filter, SunCoast filter loc
Pump Shim and Tool

GMAX 5-3 RAYBESTOS
INCLUDES ALL OF -1,-2 CONTENTS PLUS

Full proprietary SunCoast Gasket and Sealing kit

GMAX 6-1 ALTO**C-1**

- (1) Custom stepped apply plate,
- (8) external spline clutches
- (8) internal spline clutches
- (1) Custom C1 top plate.

C-2

- (7) C-2 frictions
- (8) steels
- (1) stepped apply plate

C-3

- (6) double sided waffle pattern frictions
- (5) steels
- (1) C3 Apply plate
- (1) c3 Pressure plate
- (1) p1 Carrier shim
- (1) .700 piston

C-4

- (6) internal spine single sided frictions
- (6) external spine single sided frictions
- (1) c4 apply plate
- (1) c4 pressure plate
- (1) .780 piston

**GMAX 6-2 ALTO
IN ADDITION TO -1**

Trans Go Lockup Boost Valve
TransGo® jr Shift kit®
Deep or shallow filter kit: Includes spin on,
pan filter, SunCoast filter loc
Pump Shim and Tool

**GMAX 6-3 ALTO
INCLUDES ALL OF -1,-2 CONTENTS PLUS**

Full proprietary SunCoast Gasket and Sealing
kit

GMAX 6-1 RAYBESTOS**C-1**

- (1) Custom stepped apply plate,
- (8) external spline clutches
- (8) internal spline clutches
- (1) Custom C1 top plate.

C-2

- (7) Proprietary SunCoast GPZ friction
- (9) Proprietary SunCoast steels

C-3

- (6) double sided Proprietary SunCoast frictions

(5) Proprietary SunCoast steels

- (1) C3 Apply plate
- (1) c3 Pressure plate
- (1) p1 Carrier shim
- (1) .700 piston

C-4

- (6) internal spine double sided
Proprietary SunCoast frictions
- (5) Proprietary SunCoast steels
- (1) c4 apply plate
- (1) c4 pressure plate
- (1) .780 piston

**GMAX 6-2 RAYBESTOS
IN ADDITION TO -1**

Trans Go Lockup Boost Valve
TransGo® jr Shift kit®
Deep or shallow filter kit: Includes spin on,
pan filter, SunCoast filter loc
Pump Shim and Tool

**GMAX 6-3 RAYBESTOS
INCLUDES ALL OF -1,-2 CONTENTS PLUS**

Full proprietary SunCoast Gasket and Sealing
kit

DISCLAIMER

Please specify whether shallow or deep filter is needed with purchase of -2, -3 kits. Instructions are included in kit and phone support is available during normal business hours. ALL KITS ARE INTENDED FOR PROFESSIONAL INSTALLATION. Custom kits are available upon request. Parts included are manufactured or designed in-house making it easier to tailor each kit to the needs of the customer and the potential of their vehicle.

SHOWN: **GMAX-C3R**
PROPRIETARY RAYBESTOS CLUTCH
COMES STANDARD IN RAYBESTOS GMAX KIT

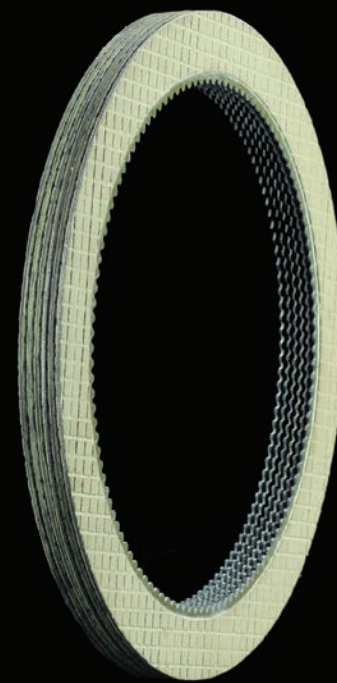

SHOWN: **GMAX-C3RI**
PROPRIETARY RAYBESTOS INTABULATOR
CLUTCH (HIGH PERFORMANCE UPGRADE)

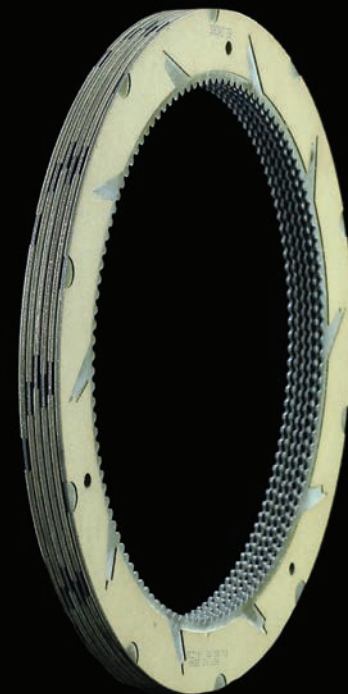

PART NUMBERDESCRIPTION WEIGHT

ALLISON REBUILD KITS

GMAX-5-1	LB7/LLY 01-05 GMAX-5 PAC	34lbs
GMAX-5-2-LB7	LB7 01-04.5 GMAX-5 PAC	40lbs
GMAX-5-2-LLY	LLY 04.5-05 GMAX-5 PAC	40lbs
GMAX-5-3-LB7	LB7 01-04.5 GMAX-5 PAC	45lbs
GMAX-5-3-LLY	LLY 04.5-05 GMAX-5 PAC	45lbs
GMAX-5R-1	LB7/LLY 01-05 GMAX-5 PAC	34lbs
GMAX-5R-2-LB7	LB7 01-04.5 GMAX-5 PAC	40lbs
GMAX-5R-2-LLY	LLY 04.5-05 GMAX-5 PAC	40lbs
GMAX-5R-3-LB7	LB7 01-04.5 GMAX-5 PAC	45lbs
GMAX-5R-3-LLY	LLY 04.5-05 GMAX-5 PAC	45lbs
GMAX-6-0	LBZ/LMM 06-10 GMAX-6 PAC	30lbs
GMAX-6-1	LBZ/LMM 06-10 GMAX-6 PAC	34lbs
GMAX-6-2	LBZ/LMM 06-10 GMAX-6 PAC	40lbs
GMAX-6-3	LBZ/LMM 06-10 GMAX-6 PAC	45lbs
GMAX-6R-1	LBZ/LMM 06-10 GMAX-6 PAC RAYBESTOS	34lbs
GMAX-6R-2	LBZ/LMM 06-10 GMAX-6 PAC RAYBESTOS	40lbs
GMAX-6R-3	LBZ/LMM 06-10 GMAX-6 PAC RAYBESTOS	45lbs

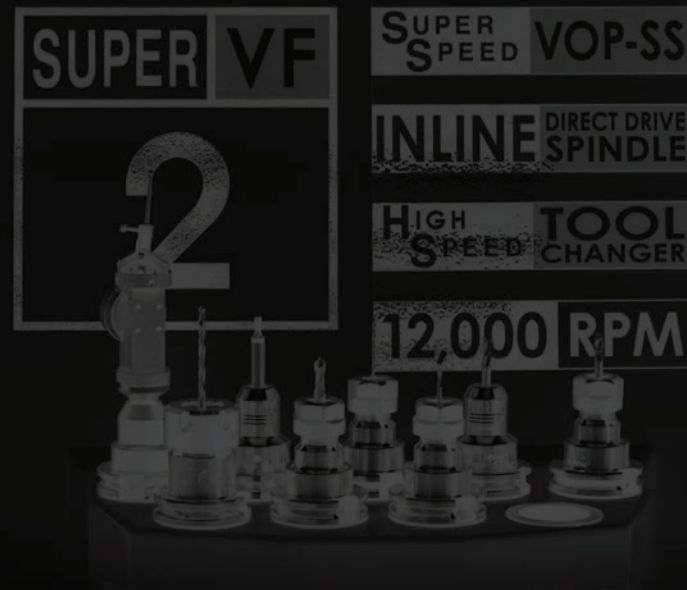

SunCoast GM ACCESSORIES

SunCoast's transmission accessory section is packed with quality designed and manufactured parts. Whether sled pulling, drag racing, or hauling heavy loads SunCoast has a variety of parts to outfit any transmission to ensure dependability when it matters most.

SunCoast Allison series hard parts combined with rebuild kits have held more power and more consecutively than that of any of the competitors.

ALLISON BILLET INPUT SHAFT: A1-109600 2001-2015: Built to withstand everything thrown at it. Made from a select grade of super strength steel.

- 50% stronger than the OEM shaft
- 9310 Vacumelt steel.
- Precision ground for high dimensional accuracy
- Ideal for heavy duty and higher horsepower race competition



applications

- Machined with larger than OEM radius at turbine spline for added strength

OUTPUT SHAFT: A1-109100 (2001-2010) A1-109102 (2011-PRESENT): Made from select grade of super strength alloys. Ideal for heavy-duty and high horsepower race or competition applications.

- 50% stronger than the OEM versions.
- Made from 300M Billet steel
- Precision ground for high dimensional accuracy.



Planetary. The stock Allison 1000 P2 Planetary can strip or snap as a result of poor tuning,



P2 PLANETARY FIX A1-P2K - 2001-2005 A1-P2K-6 - 2006-PRESENT: P2 heat-treated Planetary fix kit Contains (1) Machined P2

shock load, improperly built transmissions and higher horsepower applications and can cause catastrophic failure and/or immobility. The SunCoast P2 Planetary fix is the solution to this issue. This item is highly recommended for higher horsepower applications, including sled pulling, drag racing, as well as heavy duty towing (to accept billet P2 hub, machine work required on the P1 sun gear).

- 4140 Billet steel
- Induction heat treated
- This does not include a C2 clutch hub required if pre-shipped (planet must be build able to receive core deposit back)



ALLISON 1000 BILLET C2 HUB A1-BC2: This billet C2 hub addresses the early failure of the C-2 clutch hub in high torque/horse-pow-

er applications.

- Made from 4140 HTSR billet steel
- Spline is lengthened .125" for more contact, plus a spline boss diameter increase of .100" for added strength
- Comes with a modified thrust washer
- Machining modification to P1 Sun Gear Required

SFI APPROVED BILLET STEEL AND ALUMINUM FLEX PLATES: This replaces the factory flywheel/flex plate with a improved billet steel one piece design and eliminates the heavy cast iron and the weak stamped steel flex plate. This is a must with the high torque in conjunction with a better-designed torque converter that can transfer the torque with no slip. The flex plate is bolted to the crankshaft and then the converter is bolted to flex plate. The torque from the motor is transferred to the flex plate, then goes from the flex plate to the torque converter and finally to the input shaft in the transmission. With increased torque from the engine, it can crack and/or rip the center out of a stock flex plate.

NOTE: A SFI certified flywheel flex plate is required on drag racing vehicles running 11.99 and quicker in the 1/4 mile and 7.49 and quicker in the 1/8 mile, or any vehicle exceeding 135 mph. It was changed in 2008 from the 29.1 SFI specification to the SFI specification 29.3 for automatic transmission flex plates for diesel applications. The new rules for the flex plate requires that the material cannot be a stamped metal as are many OEM and after market flex plates. To maintain the SFI specification 29.3 requirements, the flex plate must be replaced every three years.



A1-BFP - LB7, LLY SFI APPROVED BILLET FLEX PLATE:

A1-BP-06 - LBZ, LMM SFI APPROVED BILLET FLEX PLATE:



A1-BFP-ZB - ZERO BALANCE SFI APPROVED BILLET FLEX PLATE:

A1-BFP-AZB - ALUMINUM ZERO BALANCE SFI APPROVED FLEX PLATE:

ALLISON SFI APPROVED 4.1 TRANSMISSION BLANKET: SFI-ALLISON-1: The SunCoast "BadAss Transmisison Jacket" is a custom-tailored jacket that fits to the profile of the transmission case. SFI foundation has given this jacket their "4.1" certification which allows them to meet all NHRDA, NHRA, IHRA, NADM rules and regulations. Attachment pieces for this multipurpose "BadAss Transmission jacket" will allow the vehicle to pass tech for both, drag racing and sled pulling. SunCoast designed and made the jacket in the

U.S. with the best, most proven heavy-duty/efficient safety materials available. The jacket features heavy-duty urethane coated nylon, multiple Kevlar® layers, and formulas to protect against catastrophic transmission failure. The jacket was designed by transmission specialists for ultimate driver safety.



PART NUMBERDESCRIPTION WEIGHT

ALLISON BILLET PARTS

4A1-109100	ALLISON BILLET OUTPUT SHAFT	7lbs
A1-109600	ALLISON BILLET INPUT SHAFT	10lbs
A1-109700	ALLISON INTERMEDIATE SHAFT	5lbs
A1-BC2	ALLISON BILLET C2 HUB	5lbs
A1-C2S	ALLISON SLEEVED C2 HUB	5lbs
A1-P1B	MODIFIED P1 SUN GEAR	4lbs
A1-P2K	ALLISON BILLET P2 PLANET	12lbs
A1-P2K-6	ALLISON P2 PLANET/SG C2 CAP	12lbs

ALLISON CLUTCH PAC

GMAX-C1A6	C1 6SP ALTO CARBONITE	8lbs
GMAX-C1R6	C1 6SP RAYBESTOS GPZ	8lbs
GMAX-C2A6	C2 6SP ALTO RED EAGLE	8lbs
GMAX-C2R	C2 5SP RAYBESTOS GPZ	8lbs
GMAX-C2R6	C2 6SP RAYBESTOS GPZ	8lbs
GMAX-C3A	C3 GMAX ALTO PAC	10lbs
GMAX-C3R	C3, 5/6 SP RAYBESTOS PAC	10lbs
GMAX-C3RI	C3 INTABULATOR CLUTCHES	10lbs
GMAX-C3SS	C3 SC GMAX PAC	10lbs
GMAX-C4A	C4 GMAX ALTO PAC	10lbs
GMAX-C4R	C4 RAYBESTOS CLUTCH KIT	10lbs
GMAX-C4SS	C4 GMAX PAC	10lbs

ALLISON COMPONENTS

29536962	ALLISON C2 DRIVE HUB.....	5lbs
70000	ALLISON MANUAL LEVER SHAFT SEAL	1lbs
A1-100	ALLISON P1 SHIM.....	1lbs
A1-CASE-HG	ALLISON CASE HOUSING GASKET	1lbs
A1-EXT-HG	ALLISON EXTENSION HOUSING GASKET	1lbs
A1-PR	ALLISON PR SHIM & TOOL	2lbs
A1-PR-SHIM	ALLISON PRESSURE REGULATOR SHIM.....	1lbs
A1-PRSK	ALLISON 01-10 PRESSURE.....	1lbs
A1-PUMP-HG	ALLISON PUMP HOUSING GASKET	1lbs
A1-TCB	ALLISON LB7/LLY T-CASE BRACKET.....	9lbs
A1-TCB-08	ALLISON LBZ/LMM T-CASE BRACKET	9lbs
A1-TCB-11	COMING SOON!! LML T-CASE BRACKET	9lbs

ALLISON FILTERS

29539579	ALLISON SPIN ON FILTER (RED)	1lbs
37710-12	ALLISON DEEP FILTER W/SPIN ON	3lbs
37710-12L	ALLISON DEEP W/LOC AND SPIN ON.....	3lbs
37711-12	ALLISON SHALLOW FILTER W SPIN ON	3lbs
37711-12L	ALLISON SHALLOW W/LOC AND SPIN ON.....	3lbs
515482	ALLISON SHALLOW FILTER	2lbs
515483	ALLISON DEEP FILTER	1lbs
A1-FLT-LOC-D	ALLISON DEEP FILTER LOC.....	1lbs
A1-FLT-LOC-S	ALLISON SHALLOW FILTER LOC	1lbs

ALLISON GASKET SET

T116002ASC	ALLISON 1000/2000 OHK.....	4lbs
-------------------------	----------------------------	------

ALLISON MAG PAN

MAG-A1000	ALLISON 1000 MAG-HYTEC PAN	15lbs
------------------------	----------------------------------	-------

ALLISON POWER PACKS

152755	C-1 ALTO POWERPACK.....	5lbs
152755A	C-1 ALTO POWERPACK.....	5lbs
152756	C-2 ALTO POWERPACK.....	4lbs
152756A	C-2 ALTO POWERPACK.....	4lbs
152757	C-3 ALTO POWERPACK.....	4lbs
152757A	C-3 ALTO POWERPACK 06-UP.....	4lbs
152758	C-4 ALTO POWERPACK.....	8lbs
152758A	C-4 ALTO POWERPACK 06-UP.....	8lbs
152759	C-5 ALTO POWERPACK.....	8lbs

ALLISON TORQ KITS

RGPZ-1000-1	TORQKIT DROP IN.....	5lbs
RGPZ-1000-2	TORQKIT 1000 CLUTCHE	5lbs
RGPZ-1000-3	TORQKIT 1000 CLUTCHE	5lbs
RGPZ-1001	TORQKIT C1	5lbs
RGPZ-1002	TORQKIT C2	5lbs
RGPZ-1013	TORQKIT C3 01-10	5lbs
RGPZ-1014	TORQKIT C4 01-10	10lbs
RGPZ-1023	TORQKIT C3 2011-UP	8lbs
RGPZ-1024	TORQKIT C4 2011-UP	10lbs

ALLISON VALVE BODY

A1-VB-02	ALLISON VALVE BODY 2002.....	18lbs
-----------------------	------------------------------	-------

A1-VB-03	ALLISON VALVE BODY 2	18lbs
A1-VB-04	ALLISON VALVE BODY 2	18lbs
A1-VB-05	ALLISON VALVE BODY 2	18lbs
A1-VB-06	ALLISON VALVE BODY 2	18lbs
A1-VB-TCM-LLY	LLY 6 SPD	18lbs

ALLISON VB PARTS

A1-6VB-TCM-LB7 ..	ALLISON 01-03 LB7 5-6 SPEED	24lbs
A1-6VB-TCM-LLY ..	ALLISON LLY 6 SP CONVERSION	24lbs
A1-LU-BST	ALLISON 01-04 L/U BOOST VALVE	1lbs
A1-LU-BST-04	ALLISON 04-10 L/U BOOST VALVE	1lbs
ALLISON SK	ALLISON 01-05 SHIFT KIT	4lbs
SK-ALLISON-JR	ALLISON 06-UP SHIFT KIT.....	1lbs

DURAFLITE KIT

2361848-9-3D-DF ..	DURA FLITE CONVERTER	80lbs
2561819-3D-DF	DURA FLITE CONVERTER.....	80lbs
2561827-3D-DF	DURA FLITE CONVERTER.....	80lbs
2761825-3D-DF	27 SPLINE DURAFLITE CONVERTER	80lbs
DURAFLITE 4X KIT ..	DURAFLITE INSTALL KIT	45lbs

GM ENGINE PARTS

SC LBZMAF-6	SC LBZ 5" MAF SS	1lbs
SC-LBZ-MAF-1	SC LBZ 4" MAF STEEL.....	1lbs
SC-LBZ-MAF-2	SC LBZ 5" MAF STEEL	1lbs
SC-LBZ-MAF-3	SC LBZ 4" MAF ALUM.....	1lbs
SC-LBZ-MAF-4	SC LBZ 5" MAF ALUM.....	1lbs

SC-LBZ-MAF-5	SC LBZ 4" MAF SS	1lbs
---------------------------	------------------------	------

GM SFI PRODUCTS

A1-BFP	LB7/LLY BILLET FLEX PLATE.....	20lbs
A1-BFP-AZB	ALUMINUM ZERO BALANCE	13lbs
A1-BFP-06	LBZ/LMM BILLET FLEXPLATE	20lbs
A1-BFP-ZB	ZERO BALANCE FLEXPLATE	20lbs
SFI-ALLISON-1	SFI 4.1 COVERS GEARTRAIN.....	6lbs
SFI-ALLISON-2	SFI 4.1 BELLY COMING SOON	6lbs
SFI-ALLISON-3	SFI 4.1 BELLHOUSING COMING SOON	6lbs



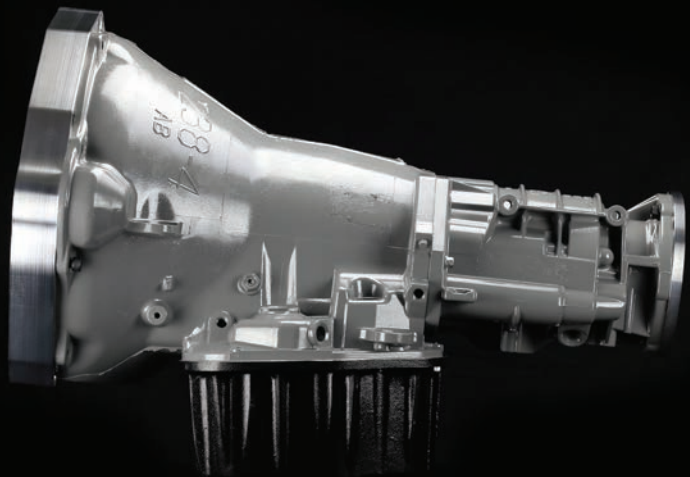

TF Gear Ratios:
1st-2.45 2nd-1.45 3rd-1.0 4th-0.69

- Billet band
- Billet strut & anchor
- Billet forward & direct piston
- Billet 4 ring accumulator piston
- Billet upgraded governor solenoid
- Billet 1-2 servo
- Multiple Input shaft options (some require custom torque converter)
- Less RPM drop between gear changes
- 70lbs + lighter, less parasitic drag

GM TRANSMISSIONS DURAFLITE

Significantly lighter in weight than that of the Allison 1000, the Dura-Flite is the ultimate performance transmission for a Duramax Diesel. The DuraFlite not only shifts faster than the Allison 1000, it also receives full power throughout the gear exchange with no de-fuel. Multiple valve bodies are available for this unit, including forward manual, reverse manual, trans brake, and full electronic to name a few. Options for shaft size are also available and vary from the standard 23 spline input, medium shaft (27 spline) and the Om3ga Shaft. CNC machined billet aluminum adapter plates, mounting hardware, tail shaft clocking ring, center support spacer, and all mounting hardware.

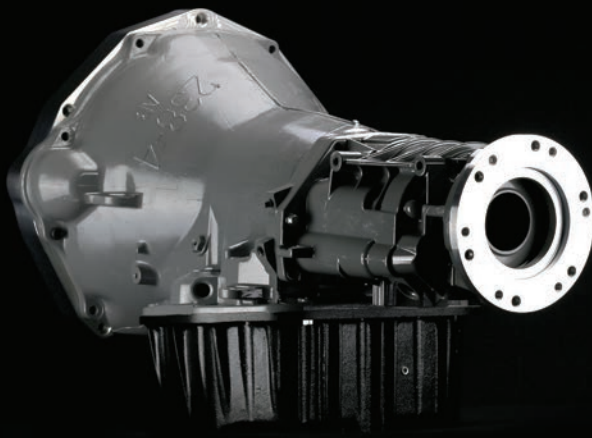

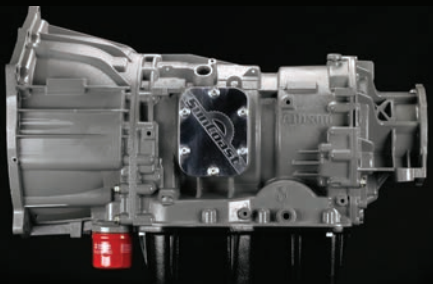

SUNCOAST TRANSMISSION WARRANTY

SunCoast Converters, Inc.(SCCI) Transmission assemblies are warranted to be free from defects in material and workmanship to the original purchaser/end user for a period of 36 months. This warranty shall terminate at the 3 year anniversary date from the time of the original invoice. SCCI reserves the right to amend this warranty at any time.

SCCI's liability under this warranty is limited to repair or replacement, at its option, subject to the provisions set forth herein of any parts, which upon examination by SCCI, are found to be defective. SCCI reserves the right to determine the course of action in regard to repair and/or replacement of any and all warrantable products and/or services.

During the first 12 months of warranty, SCCI will arrange shipping. This reimbursement will be made only to an authorized automotive repair facility provided that the original installation was performed by an approved SCCI Installation facility. After the first 12 months of the warranty, SCCI will cover parts cost only for the remaining 24 months of warranty. Any labor and shipping costs after the first 12 months of the warranty will be the responsibility of the customer. The warranty does not cover fluids and filters. Third party electrical components are warranted for 90 days from original invoice date.

Any part submitted for warranty consideration must be returned to SCCI, accompanied with a copy of proof of purchase (invoice), a description of the concern/complaint, and service history records. Repaired or replaced products will be returned to the customer freight collect. All warranted parts that have been replaced become the sole property of SCCI.

WHAT IS NOT COVERED UNDER THIS WARRANTY

This warranty shall not apply to any product that has been tampered with, improperly installed, damaged as a result of accident or neglect, improperly repaired or altered by the customer or his agent/tech, or abused resulting in broken, sheered, or fractured shafts and/or gears. This warranty shall not apply to any products damaged due to low fluid conditions, any competitive use (i.e. sled pulling or drag racing), or any commercial applications which tow weights in excess of manufacturer's GCVWR. SCCI will not warranty broken, sheered, or fractured shafts and/or drums; or any damage associated with broken shafts or drums.

SCCI will not be liable for towing charges, rental car, travel/lodging expenses or any other claims for special,

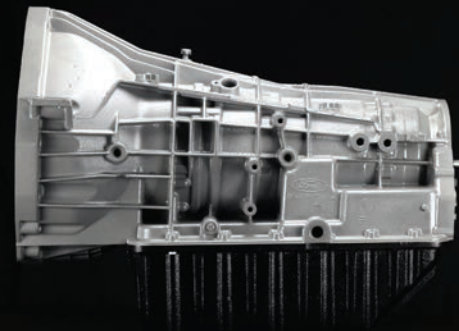

SUNCOAST CONVERTERS INC. LIMITED COMPETITION WARRANTY DISCLOSURE

SunCoast Converters Inc. (SCCI) Transmission assemblies are warranted to be free from manufacturer's defects in material and workmanship to the original purchaser/end user for a period of 12 months. This warranty shall terminate at the 1 year anniversary date from the time of the original invoice. We do recommend that you send your transmission back to us during your off season each year for a check-up. SCCI Liability under this warranty is limited to repair or replacement, at its option, subject to the provisions set forth herein, of any parts which upon examination by SCCI are found to be defective. SCCI reserves the right to determine the course of action in re-

gard to repair and/or replacement of any and all warrantable products and/or services. Any part submitted for warranty consideration must be returned to SCCI, pre-paid shipping, accompanied with a copy of proof of purchase (invoice), a description of the concern, and service history. Repaired or replaced products will be returned to the customer freight collect. All warranted parts that have been replaced become sole property of SunCoast Converters Inc. Third party electrical components are covered for 90 days.

WHAT IS NOT COVERED UNDER WARRANTY:

This warranty shall not apply to any product that has been tampered with, improperly installed, damaged as the result of accident or neglect, improperly repaired or altered by the owner or his agent/tech, or abused resulting in broken, fractured, or sheered shafts and/or gears. This warranty shall not apply to any products damaged due to low fluid conditions. Any labor cost incurred, including shipping charges, will be the responsibility of the customer. SCCI will not pay for fluid and/or filters. If a billet shaft breaks, SCCI will not

warranty the parts damaged by the shaft and will not warranty the billet shaft. SCCI will not be liable for towing charges, rental car, travel/lodging expense or any other claims, including claims for special, indirect, or consequential damages that may arise under the provisions of this warranty.



SunCoast TORQUE CONVERTER WARRANTY

SunCoast Converters Inc. (SCCI) torque converters are warranted to be free from defects in material and workmanship to the original purchaser/end user for a period of 36 months. This warranty shall terminate at the 3 year anniversary date from the time of the original invoice.

THIS WARRANTY SHALL NOT COVER PRODUCTS USED IN COMPETITIVE EVENTS (I.E., DRAG RACING, SLED PULLING)

SCCI Liability under this warranty is limited to repair or replacement at its option, subject to the provisions set forth herein, of any parts which upon examination by SCCI are found to be defective. SCCI reserves the right to determine the course of action in regard to repair and/or replacement of any and all warrantable products and/or services. Any part submitted for warranty consideration must be returned to SCCI Pre-paid shipping accompanied with a copy of proof of purchase (invoice), a description of the concern, and service history. Repaired or replaced products will be returned

to the customer freight collect. All warranted parts that have been replaced become sole property of SunCoast Converters Inc.

ANY LABOR COST INCURRED, INCLUDING SHIPPING CHARGES, WILL BE THE RESPONSIBILITY OF THE CUSTOMER.

This warranty shall not apply to any product that has been improperly installed, damaged as a result of accident or neglect, improperly repaired or altered by the owner or his agent/tech. This warranty shall not

SCCI will not be liable for towing charges, travel/lodging expense or any other claims including claims for special, indirect, or consequential damages that may arise under the provisions of this warranty.

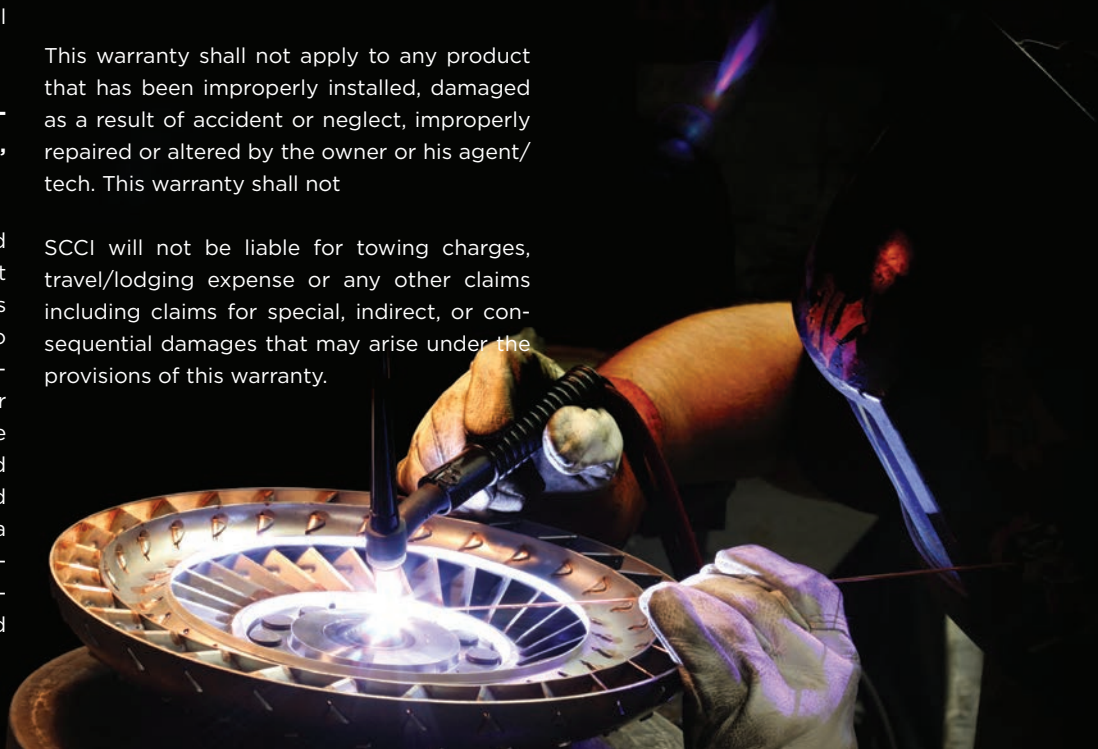

SC-MSS | MENS SHORT SLEEVE



SC-MLS | MENS LONG SLEEVE



SC-ZUH | ZIP UP HOODIE



SC-WVS | WOMENS VNECK SHIRT



SC-WSS | WOMENS SHORT SLEEVE



SC-FFB | FITTED FIAT BILL S/M OR L/XL



SC-GB | GEL BADGE

SC-GI | GEL INTABULATOR

SC-VI | VINYL INTABULATOR

SC-VDTS | VINYL DIESEL TRANSMISSION



SC-BBO | BILLET BOTTLE OPENER



SC-WSS | DRINK KOOZIE

LOGO USAGE

Consistent adherence to the color guidelines will help build visibility and recognition of your association with the brand. If pantone 1585c is not available for print purposes, you may use a one color logo of black or white, depending on the background.

+ Full-Color

In the preferred use of the primary SunCoast logo, the logo is black with the letters CO in orange, placed on a white or no more than 25% grey background.



+ Size & Spacing

The space between the logo and any other object must always be the height of the SunCoast letters.

REVERSE LOGO USAGE

Consistent adherence to the color guidelines will help build visibility and recognition of your association with the brand. If pantone 1585c is not available for print purposes, you may use a one color logo of black or white, depending on the background.

+ Full-Color Reverse Logo

In the preferred use of the primary SunCoast logo, the logo is white with the letters CO in orange, placed on a black or no lighter than 75% grey background.



+ Angel of Rotation

The logo must never be rotated to any other angle but illustrated. 15 degrees counter clockwise.

LOGO IMPROPER USE

The integrity of the logo must be respected at all times. Don't stretch, condense or otherwise alter or manipulate it. Any modification of the logo confuses its meaning and diminishes its impact.

1. Do not re-create or retype the words.
2. Do not stretch or alter our logo in any way.
3. Do not change our logo color.
4. Do not use graphic effects or outlines on our logo. Do not emboss the logo.
5. Do not place our logo in a shape.
6. Do not overlap other graphics or text or photography.
7. Do not screen the logo. It should always print at 100% ink density.
8. Do not rearrange the type, or change the size of name in proportion to the icon.

1



3



5



7



2



4



6







8



COLOR SCHEME

Do not use any other colors, other than the ones listed below. Print on uncoated stock, matching Pantone 1585 C and Pantone Neutral Black c. No other colors may be used to substituted this pantone color codes for print. If you are unable to print in color, or if you are unsure that you can visually match the colors listed, you must print in two-color black and white, or black only on a white background. No other colors may be substituted. The only instance the logo may be used in a color scheme other than the stated pantones are for custom paint match scenarios for vehicles decals approved and supplied by SunCoast.

	Pantone Color Code	CMYK	RGB	HTML
	Pantone 1585c	0/71/98/0	255/109/16	ff6d10
	Pantone 416c	52/42/52/10	126/127/116	7e7f74
	Pantone Neutral Black c	72/66/65/72	34/34/34	222222
	Custom Paint Color Match	NA	NA	NA

TYPOGRAPHY

Gotham HTF Medium Condensed and Gotham HTF Book, are the only acceptable fonts to use in any advertising for print or web assets.

Gotham HTF: Medium Condensed

ABCDEFGHIJKLMNOPQRSTUVWXYZ
abcdefghijklmnopqrstuvwxyz
1234567890

Gotham HTF: Book

ABCDEFGHIJKLMNOPQRSTUVWXYZ
abcdefghijklmnopqrstuvwxyz
1234567890